

Fleet-Lift™ System Overview

The Dayton Superior Fleet-Lift System comprises two main parts, the Fleet-Lift Anchor and the Fleet-Lift Ring Clutch. The design of the system allows loads to be applied from any direction.

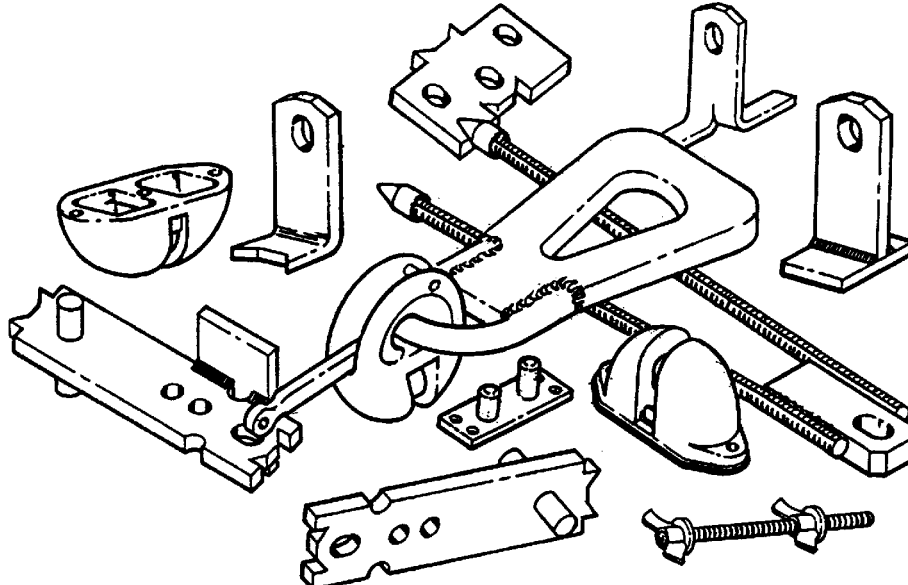

Fleet-Lift System Components

The selection of the proper capacity Fleet-Lift System is based on several factors, such as:

- Size of precast element
- Rigging configuration
- Compressive strength of concrete at initial lift
- Embedment depth of anchor
- Edge distance
- Anchor spacing
- Direction of applied load
- Use of tension bars, shear bars or shear plates.

Each Fleet-Lift anchor is stamped with its MAXIMUM safe working load and the letters DSC, which identifies it as a Dayton Superior Corporation product. The hole near the top of the anchor head is designed to receive the appropriate size ring clutch.

Both the anchor and ring clutch are rated with a safe working load. The safe working load of the anchor is based on a factor of safety of 4 to 1 (ultimate to safe). Each ring clutch has a Load Range embossed on it, which shows the anchors it can be used with. A factor of safety of 5 to 1 is applied to the highest load in the range for each size of ring clutch.

To use, simply push the ring clutch onto the head of the anchor that is located in a recess created by a Fleet-Lift recess plug. Once the ring clutch is pushed onto the head of the anchor, the ring clutch's curved bolt is pushed through the hole in the anchor. This locks the ring clutch and anchor into a single unit ready to lift the precast concrete element.

To disengage the anchor and ring clutch, simply pull the curved bolt free of the anchor. This allows the ring clutch to be easily removed from the head of the anchor.

Dayton Superior recommends a minimum 3/4" cover between the bottom of an anchor and the concrete surface. This minimum recommended concrete cover is to prevent anchor corrosion.

P91S Fleet-Lift™ Ring Clutch

The P91S Fleet-Lift Ring Clutch consists of a clutch body, a curved bolt and a high strength bail. Installation and release is safe and simple. After the clutch is inserted over the anchor head and into the recess, the curved bolt is rotated into the closed position.

Rotation of the standard bail is a full 360°. Once engaged and supporting four hundred pounds of load, the ring clutch cannot be released.

To Order:

Specify: (1) quantity, (2) name, (3) product code, (4) system size.

Example:

9, P91S Fleet-Lift Ring Clutches, FL002S, 4/6-ton units.



P91S Fleet-Lift Ring Clutch

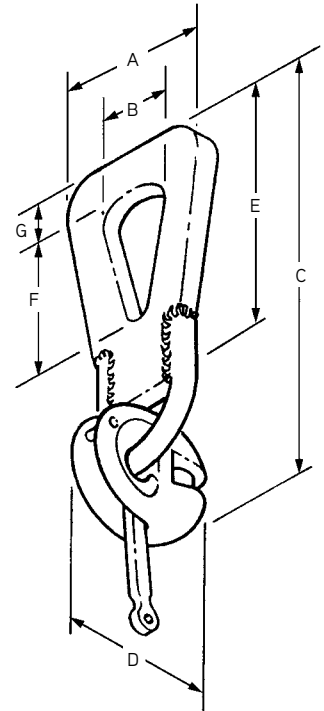

P91S Fleet-Lift Ring Clutch

Selection Table

Safe Working Load (Tons)	Load Range (Tons)	Product Code	A	B	C	D	E	F	G
3	1-3	FL001S	3-3/4"	2-3/8"	10-1/2"	3"	7"	3"	1"
6	4-6	FL002S	4-3/4"	2-5/8"	12-1/2"	4"	8-1/4"	3-1/2"	1-1/2"
12	8-12	FL003S	5-7/8"	3"	17-3/4"	5-7/8"	11"	4-1/2"	2-1/8"

Safe Working Load provides a factor of safety of approximately 5 to 1.

Installation of P91S Ring Clutch

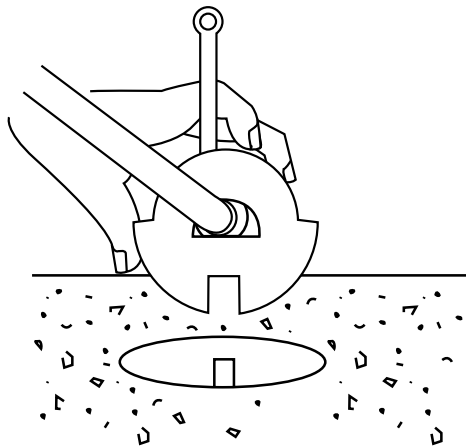

The P91S Ring Clutch is located directly over the head of a Fleet-Lift Anchor.

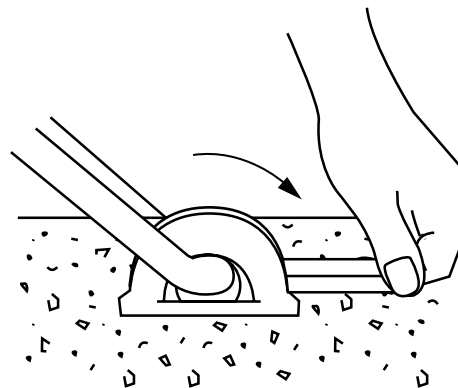

The ring clutch is pushed down onto the anchor head and the curved bolt is rotated through the engagement hole of the anchor and locked into position. The process of engaging anchor and ring clutch is completed in seconds.

Fleet-Lift™ System

P91NC Fleet-Lift™ Cable Bail Ring Clutch

The Fleet-Lift Ring Clutch with cable bail can be the solution to many difficult lifting and rotating-to-vertical situations. Cable bails can also be used to replace bent or damaged bails on standard clutches.

The engagement, use and release of the Cable Bail Ring Clutch are similar in operation to the standard Ring Clutch with the fixed bail.

Once the load is relaxed, the ring clutch can be easily released.

P91NC Fleet-Lift Cable Bail Ring Clutch Selection Table

Safe Working Load (Tons)	Load Range (Tons)	Product Code	A	B	C	D	E
3	1-3	FL001NC	30"	9/16"	2-3/4"	2-3/8"	4-3/8"
6	4-6	FL002NC	36"	3/4"	3-11/16"	3-3/8"	6-5/8"
10	8-10	FL003NC	48"	1"	5-5/16"	3-3/4"	7-1/8"

Safe working load provides a factor of safety of approximately 5 to 1.

To Order:

Specify: (1) quantity, (2) name, (3) product code, (4) system size.

Example:

9, P91NC Fleet-Lift Cable Bail Ring Clutches, FL002NC, 4/6-ton units.

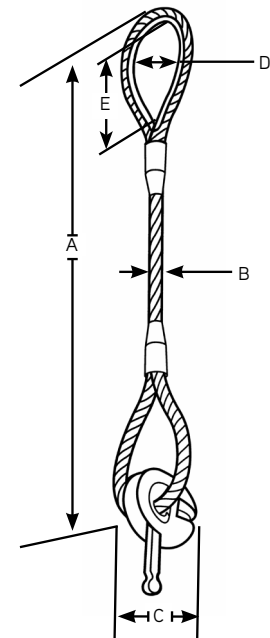

P91NC Fleet-Lift Cable Bail Ring Clutch

Inspection and Maintenance of Ring Clutches

The Fleet-Lift P91S and P91NC Ring Clutches may be subject to wear, misuse, overloading and many other factors that may affect a Ring Clutch's safe working load.

The users must establish a program for inspection of their Ring Clutches based on their frequency of use. Inspections should consist of the following:

1. Determine the general overall condition and wear.
2. Make certain the bail can rotate freely in all directions.
3. If evidence of heat application is found, the clutch must be destroyed.
4. Check for bent or twisted bails.
5. Check for worn or bent curved bolt.
6. Check for worn or deformed main clutch body.
7. Check for enlarged engagement slot.

During inspection of the clutch body, if the engagement slot is found to exceed dimension W, remove the ring clutch from service and destroy it.

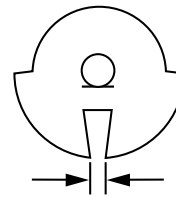

Safe Working Load (Tons)	Load Range (Tons)	W
3	1-3	0.562"
6	4-6	0.781"
10	8-10	0.921"

Note: Destroy all units if found to be worn, damaged, bent or twisted. The proper method for use in destroying a Ring Clutch is to cut off and remove the bail. No repair or welding on Fleet-Lift Ring Clutches is permitted.

Additional Inspection of Cable Bails

Before every use, inspect the wire cable for:

1. Damage or extreme wear
2. Bends or kinks
3. Fraying or loosening of outer strands
4. Squeezes in the free length
5. Squeezes in the support area
6. Cable swelling
7. Cable ruptures in excess of four runners in three diameters of the cable length, six runners in six diameters of the cable length or sixteen runners in 30 diameters of cable length.

If the cable is damaged, it must be replaced. Dayton Superior can arrange for cable replacement. Contact the nearest Dayton Superior Technical Assistance for information and cost.

P92 Fleet-Lift™ Erection Anchor

Fleet-Lift P92 Erection Anchors are specifically designed for horizontal to vertical edge lifts and handling of thin-walled precast concrete elements. Two steel protrusions or “ears” on the head of the anchor provide protection against concrete spalling. These protrusions restrict the ring clutch rotation during lateral pulls. As a result, lateral forces are transmitted directly to the edge of the anchor instead of the concrete.

The body of the Erection Anchor is shaped to allow full reinforcement for secure support and spall-free rotation.

P92 Erection Anchors are available plain or hot-dipped galvanized.

To Order:

Specify: (1) quantity, (2) name, (3) anchor style, (4) corrosion resistance, if required.

Example:

200, P92 Fleet-Lift Erection Anchors, FL047, hot-dipped galvanized.

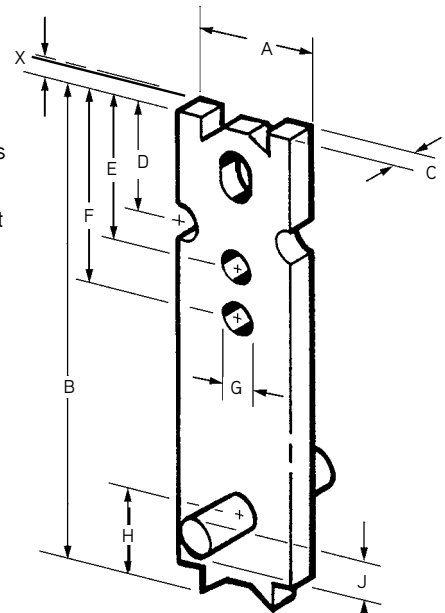

P92 Fleet-Lift Erection Anchor

P92 Fleet-Lift Erection Anchor Dimensions

Safe Working Load (Tons)	Product Code	A	B	C	D	E	F	G	H	J	X
2	FL047	2"	8-1/16"	3/8"	1-13/16"	2-3/8"	3-3/8"	5/8"	3/4"	1/2"	3/8"
4	FL048	2-1/2"	10-1/2"	5/8"	2-1/2"	3-3/16"	4-7/16"	3/4"	1"	3/4"	7/16"
8	FL049*	3-3/4"	12-5/8"	3/4"	3-1/8"	4"	5-3/4"	1"	1-1/4"	3/4"	5/8"

Note: Dimension X is distance from surface of concrete to anchor

Shear Reinforcement

Stress is caused during the edge lift of a panel, making supplemental reinforcement around the anchor necessary in thin panels. Fleet-Lift P98S Shear Bars are designed expressly for this purpose. Place the shear bar in the side notch of the anchor as shown in the sketch at right.

Reference P98S Shear Bar section for more information.

Note: A properly installed P98S Shear Bar is required to develop the shear safe working loads shown in the chart on the following page.

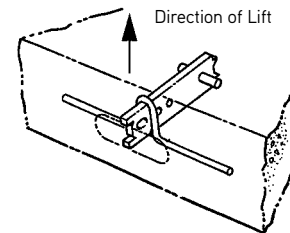

Typical P92 Fleet-Lift Erection Anchor/ Shear Bar Application

Tension Reinforcement

The P92 Dayton Superior Fleet-Lift Erection Anchor is manufactured with a steel tension pin that resists pullout during normal erection situations. The safe working load chart, on the following page, list two sets of tension values. If the higher safe working load is used, the anchor must be properly reinforced using the P98T Tension Reinforcement. The tension bar should be placed through the lower hole of the anchor.

Reference P98T Tension Reinforcement section for more information.

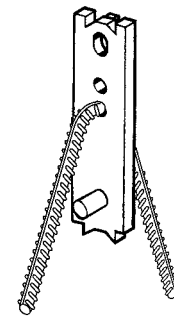

Typical P92 Fleet-Lift Erection Anchor/Tension Bar Application

P92 Fleet-Lift Erection Anchor Tension and Shear Capacities

P92 Fleet-Lift Erection Anchor (ton x length)	Product Code	Precast Concrete Panel Thickness	Shear Safe Working Load with Shear Bar	Tension Safe Working Load with Anchor Only	Tension Safe Working Load With Tension Bar
2-ton x 8" long	FL047	4" Min.	1,650 lbs.	2,575 lbs.	4,000 lbs.
		5"	1,875 lbs.	3,350 lbs.	
		6"	2,125 lbs.	3,850 lbs.	
		7"	2,400 lbs.	4,000 lbs.	
		8"	2,700 lbs.	4,000 lbs.	
		9"	2,925 lbs.	4,000 lbs.	
		10"	3,275 lbs.	4,000 lbs.	
		11"	3,575 lbs.	4,000 lbs.	
4-ton x 10-7/16" long	FL048	5-1/2" Min.	2,400 lbs.	4,700 lbs.	8,000 lbs.
		6"	3,075 lbs.	5,050 lbs.	
		7"	3,250 lbs.	5,825 lbs.	
		8"	3,425 lbs.	6,600 lbs.	
		9"	3,825 lbs.	7,350 lbs.	
		10"	4,250 lbs.	8,000 lbs.	
		11"	4,650 lbs.	8,000 lbs.	
		12"	5,050 lbs.	8,000 lbs.	
8-ton x 13-1/4" long	FL049	7-1/2" Min.	4,000 lbs.	7,500 lbs.	16,000 lbs.
		8"	4,200 lbs.	7,775 lbs.	
		9"	4,550 lbs.	8,300 lbs.	
		10"	4,950 lbs.	8,800 lbs.	
		11"	5,050 lbs.	10,000 lbs.	
		12"	5,175 lbs.	11,300 lbs.	

Notes:

1. Safe Working Loads are based on approximately a 4 to 1 factor of safety in 3,500 psi normal weight concrete.
2. Install shear bar and tension bar, when required, per instructions on preceding page.

P92P Fleet-Lift™ Erection Anchor with Shear Plate

The P92P Fleet-Lift Erection Anchor with Shear Plate is designed specifically for edge tilting precast concrete elements from the horizontal to a vertical position. An integral shear plate eliminates any possibility of forgetting to install a required shear bar.

As on other Fleet-Lift Erection Anchors, two steel protrusions or “ears” at the head of the anchor provide protection against concrete spalling. These “ears” restrict the ring clutch rotation during lateral pulls. As a result, lateral forces are transmitted directly to the edge of the anchor instead of the concrete.

The body of the erection anchor is shaped to allow full reinforcement for secure support and spall-free rotation.

P92P Erection Anchors are available plain or hot-dipped galvanized.

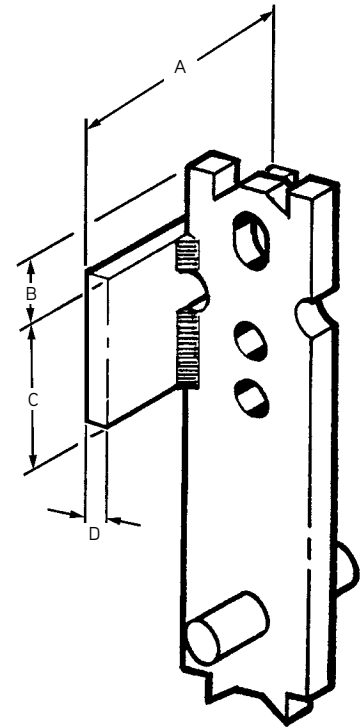

P92P Fleet-Lift Erection Anchor with Shear Plate

To Order:

Specify: (1) quantity, (2) name, (3) product code, (4) corrosion resistance, if required.

Example:

200, P92P Fleet-Lift Erection Anchor with Shear Plate, FL148, hot-dipped galvanized.

Safe Working Load (Tons)	Product Code	A	B	C	D
2	FL147	2-1/2"	3/4"	3"	1/4"
4	FL148	2-1/2"	1-1/4"	3"	3/8"
8	FL149*	3"	1-5/8"	3-1/2"	3/8"

Anchor dimensions not shown are the same as the P92 Erection Anchor of the same load range.

Shear Reinforcement

Stress is caused during the edge lifting of a precast panel, making supplemental reinforcement around the anchor necessary in thin panels. The Fleet-Lift P92P Erection Anchor with integral Shear Plate is designed expressly for this purpose. Install the anchor so that the shear plate is opposite the direction of lift.

Typical P92P Fleet-Lift Erection Anchor with Shear Plate Application

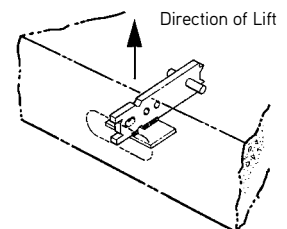

Tension Reinforcement

The P92P with Shear Plate Fleet-Lift Erection Anchor is manufactured with a steel tension pin that resists pullout during normal erection situations. The safe working load chart on the following page lists two sets of tension values. If the higher safe working load is used, the anchor must be properly reinforced using the P98T Tension Bar. The tension bar should be placed through the lower hole.

Typical P92P Fleet-Lift Erection Anchor Shear Plate/Tension Bar Application

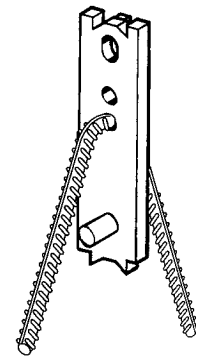

P92P Fleet-Lift Erection Anchor with Shear Plate Capacities

P92 Fleet-Lift Erection Anchor (ton x length)	Product Code	Precast Concrete Panel Thickness	Shear Safe Working Load with Shear Bar	Tension Safe Working Load with Anchor Only	Tension Safe Working Load With Tension Bar
2-ton x 8" long	FL147	3-1/2" Min.	1,450 lbs.	2,575 lbs.	4,000 lbs.
		4"	1,625 lbs.	2,575 lbs.	
		5"	2,050 lbs.	3,350 lbs.	
		6"	2,350 lbs.	3,750 lbs.	
		7"	2,625 lbs.	3,850 lbs.	
		8"	2,850 lbs.	4,000 lbs.	
		9"	3,050 lbs.	4,000 lbs.	
		10"	3,225 lbs.	4,000 lbs.	
		11"	3,425 lbs.	4,000 lbs.	
		12"	3,675 lbs.	4,000 lbs.	
4-ton x 10-7/16" long	FL148	4" Min.	2,150 lbs.	3,450 lbs.	8,000 lbs.
		5"	2,625 lbs.	4,250 lbs.	
		6"	3,100 lbs.	5,075 lbs.	
		7"	3,525 lbs.	5,825 lbs.	
		8"	3,925 lbs.	6,600 lbs.	
		9"	4,275 lbs.	7,350 lbs.	
		10"	4,600 lbs.	8,000 lbs.	
		11"	4,900 lbs.	8,000 lbs.	
		12"	5,150 lbs.	8,000 lbs.	
		8-ton x 13-1/4" long	FL149	6" Min."	
7"	4,250 lbs.			6,870 lbs.	
8"	4,475 lbs.			7,775 lbs.	
9"	4,725 lbs.			8,300 lbs.	
10"	4,950 lbs.			8,800 lbs.	
11"	5,200 lbs.			10,000 lbs.	
12"	5,450 lbs.			11,300 lbs.	

Notes:

- 1) Safe Working Loads are based on approximately a 4 to 1 factor of safety in 3,500 psi normal weight concrete.
- 2) FL449 uses 8-10T P99 Recess and P91 Ring Clutch.

P92DP Fleet-Lift™ Erection Anchor with Shear Plate and Shear Pin

The Dayton Superior P92DP Fleet-Lift Erection Anchor with a Shear Plate and a Shear Pin is similar to the P92P anchor with the addition of a shear pin. By welding a solid shear pin opposite the shear plate, the anchor can resist shear loads in both directions.

Installation and Primary Shear Loading

The P92DP anchor is set in the form with the shear plate in the down position to resist the primary shear load.

Secondary Shear Loading

When the panel is placed on an "A" frame is required to be rotated 180°, the addition of the shear pin works with the shear plate to resist the shear load in the opposite direction of the shear plate. The shear pin helps to protect the concrete from spalling when the shear loads are applied in a secondary direction.

P92DP Erection Anchors are available either plain or hot-dipped galvanized steel.

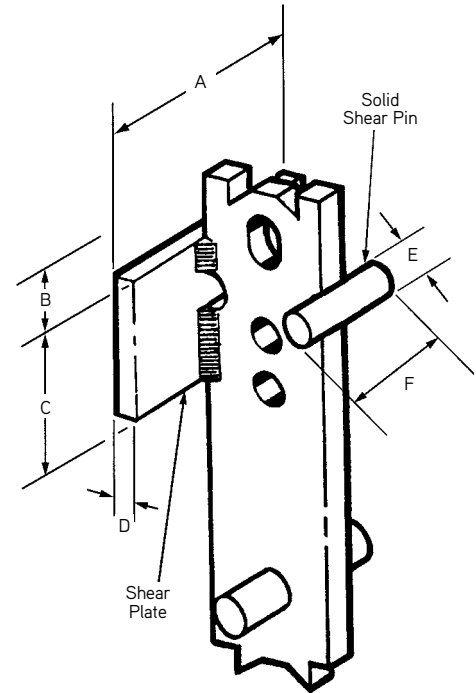

P92DP Fleet-Lift Erection Anchor with Shear Plate/Pin

To Order:

Specify: (1) quantity, (2) name, (3) product code, (4) corrosion resistance, if required.

Example:

200, P92DP Fleet-Lift Erection Anchor with Shear Plate/Pin, FL744, 4/6-ton system size, hot-dipped galvanized.

Safe Working Load (Tons)	Product Code	A	B	C	D	E	F
2	FL647	2-1/2"	3/4"	3"	1/4"	1/2"	2-3/4"
4	FL648	2-1/2"	1-1/4"	3"	3/8"	3/4"	2-7/8"
8	FL649	3"	1-5/8"	3-1/2"	3/8"	3/4"	2-7/8"

Anchor dimensions not shown are the same as the P92 Erection Anchor of the same load range.

Tension Reinforcement

The P92DP Fleet-Lift Erection Anchor is manufactured with a steel tension pin that resists pullout during normal erection situations. The safe working load chart on the following page lists two sets of tension values. If the higher safe working load is used, the anchor must be properly reinforced using the P98T Tension Bar. The tension bar should be placed through the lower hole of the anchor.

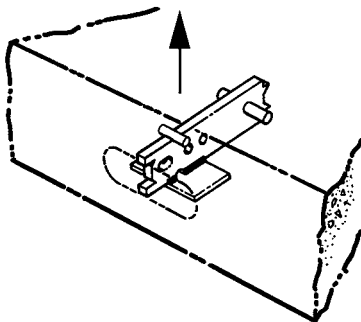

Direction of Lift for Primary Shear

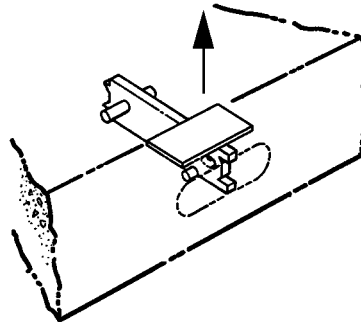

Direction of Lift for Secondary Shear

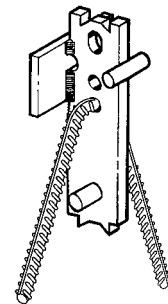

P92DP Fleet-Lift Erection Anchor with Shear Plate and Shear Pin Capacities

P92DP Fleet-Lift Erection Anchor (ton x length)	Product Code	Precast Concrete Panel Thickness	Shear Safe Working Load with Shear Plate	Shear Safe Working Load for Secondary Shear	Tension Safe Working Load with Anchor Only	Tension Safe Working Load With Tension Bar
2-ton x 8" long	FL647	3-1/2" Min.	1,450 lbs.	1,150 lbs.	2,575 lbs.	4,000 lbs.
		4"	1,625 lbs.	1,300 lbs.	2,575 lbs.	
		5"	2,050 lbs.	1,650 lbs.	3,350 lbs.	
		6"	2,350 lbs.	1,750 lbs.	3,750 lbs.	
		7"	2,625 lbs.	1,875 lbs.	3,850 lbs.	
		8"	2,850 lbs.	2,100 lbs.	4,000 lbs.	
		9"	3,050 lbs.	2,275 lbs.	4,000 lbs.	
		10"	3,225 lbs.	2,450 lbs.	4,000 lbs.	
		11"	3,425 lbs.	2,575 lbs.	4,000 lbs.	
		12"	3,675 lbs.	2,950 lbs.	4,000 lbs.	
4-ton x 10-7/16" long	FL648	4" Min.	2,150 lbs.	1,725 lbs.	3,450 lbs.	8,000 lbs.
		5"	2,625 lbs.	2,100 lbs.	4,250 lbs.	
		6"	3,100 lbs.	2,475 lbs.	5,075 lbs.	
		7"	3,525 lbs.	2,825 lbs.	5,825 lbs.	
		8"	3,925 lbs.	3,150 lbs.	6,600 lbs.	
		9"	4,275 lbs.	3,425 lbs.	7,350 lbs.	
		10"	4,600 lbs.	3,675 lbs.	8,000 lbs.	
		11"	4,900 lbs.	3,925 lbs.	8,000 lbs.	
		12"	5,150 lbs.	4,125 lbs.	8,000 lbs.	
8-ton x 13-1/4" long	FL649	6" Min."	4,000 lbs.	3,200 lbs.	5,580 lbs.	16,000 lbs.
		7"	4,250 lbs.	3,400 lbs.	6,870 lbs.	
		8"	4,475 lbs.	3,575 lbs.	7,775 lbs.	
		9"	4,725 lbs.	3,775 lbs.	8,300 lbs.	
		10"	4,950 lbs.	3,975 lbs.	8,800 lbs.	
		11"	5,200 lbs.	4,150 lbs.	10,000 lbs.	
		12"	5,450 lbs.	4,350 lbs.	11,300 lbs.	

Notes:

- 1) Safe Working Load is based on an approximate factor of safety of 4 to 1 in 3,500 psi normal weight concrete.
- 2) Install anchors as shown on preceding page to develop safe working loads in chart.

P92FE Fleet-Lift™ Forged Erection Anchor

The Dayton Superior P92FE Forged Erection Anchor is specifically designed to provide greater lifting capacities for horizontal to vertical edge lifts. The anchors are forged to provide 50% greater safe working loads. The head of the anchor is designed with two protrusions or "ears" on the head of the anchor which provide protection against concrete spalling. These protrusions restrict the ring clutch rotation during lateral pulls. As a result, lateral forces are transmitted directly to the edge of the anchor instead of the concrete.

The P92FE Forged Erection Anchor utilizes the Fleet P91S or Fleet P91NC lifting hardware and the P99 Recess Plugs.



Fleet-Lift™ System

P92FE Capacity	Product Code	Finish
3-Ton	127518	HDG
6-Ton	143421	HDG
12-Ton	100669	HDG
12-Ton	100668	Plain

To Order:
Specify: (1) quantity, (2) name, (3) product code,

Example:
200, P92FE Fleet-Lift Forged Erection Anchors, #127518

P92FE Forged Erection Anchor

Ton x Length	Slab Thickness	Insert Height	Minimum Edge Distance	Minimum Corner Distance	Shear Safe Working Load with Shear Bar	Tension Safe Working Load Anchor Only	Tension Safe Working Load with Tension Bar
3-ton x 8"	4" Min.	8"	2"	12"	1,390 lbs.	2,500 lbs.	6,000 lbs.
	5"		2-1/2"		1,680 lbs.	3,130 lbs.	
	6"		3"		1,980 lbs.	3,760 lbs.	
	7"		3-1/2"		2,300 lbs.	4,380 lbs.	
	8"		4"		2,630 lbs.	5,010 lbs.	
	9"		4-1/2"		2,980 lbs.	5,640 lbs.	
	10"		5"		3,340 lbs.	6,000 lbs.	
	11"		5-1/2"		3,720 lbs.	6,000 lbs.	
	12"		6"		4,110 lbs.	6,000 lbs.	
6-ton x 10-3/8"	5-1/2" Min.	10-3/8"	2-3/4"	16"	2,840 lbs.	4,720 lbs.	12,000 lbs.
	6"		3"		3,030 lbs.	5,150 lbs.	
	7"		3-1/2"		3,430 lbs.	6,010 lbs.	
	8"		4"		3,840 lbs.	6,870 lbs.	
	9"		4-1/2"		4,270 lbs.	7,730 lbs.	
	10"		5"		4,710 lbs.	8,590 lbs.	
	11"		5-1/2"		5,010 lbs.	9,450 lbs.	
	12"		6"		5,540 lbs.	10,310 lbs.	
12-ton x 12-3/4"	7 1/2"	12-3/4"	3-3/4"	19"	4,180 lbs.	7,920 lbs.	24,000 lbs.
	8"		4"		4,420 lbs.	8,440 lbs.	
	9"		4-1/2"		4,920 lbs.	9,500 lbs.	
	10"		5"		5,430 lbs.	10,560 lbs.	
	11"		5-1/2"		5,950 lbs.	11,610 lbs.	
	12"		6"		6,490 lbs.	12,670 lbs.	

Safe Working Load provides a factor of safety approximately 4 to 1 in 3,500 psi normal weight concrete.

P92FEW Fleet-Lift™ Forged Erection Anchor with Shear Plate

The P92FEW Forged Erection Anchor with Shear Plate eliminates the need for a shear bar. The P92FE and P92FEW anchors are stocked in plain and galvanized finishes.

P92FEW Capacity	Product Code (Plain)	Product Code (Galvanized)
3 Ton	129473	139577
6 Ton	143424	143425
10 Ton	143426	143427
12 Ton	100148	100149

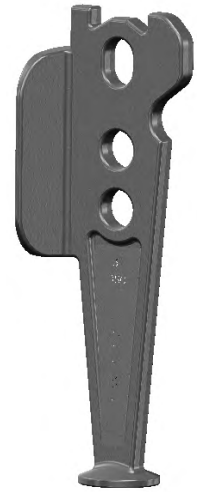

Fleet-Lift™ System

To Order:

Specify: (1) quantity, (2) name, (3) product code, (4) finish.

Example:

200, P92FEW Fleet-Lift Forged Erection Anchors, #139577, hot-dipped galvanized.

P92FEW Fleet Forged Erection Anchor

Anchor	Length	Width	Plate Length	Plate Width	Slab Thickness	Minimum Corner Distance	Shear SWL with Shear Plate (lbs)	Tension SWL Anchor Only (lbs)	Tension SWL with Tension Bar (lbs)
3 Ton x 8"	8"	2.32"	3.5"	2.5"	4"	12"	1,800	6,000	6,000
					5"		2,300		
					6"		2,800		
					7"		3,400		
					8"		4,000		
					9"		4,400		
					10"		4,800		
					11"		5,200		
6 Ton x 10.45"	10.45"	2.88"	4.0"	3.08"	5.5"	16"	3,100	12,000	12,000
					6"		3,250		
					7"		3,700		
					8"		4,040		
					9"		4,600		
					10"		5,000		
					11"		5,500		
					12"		6,100		
10 Ton x 12.56"	12.56"	4.76"	4.0"	3.2"	7.5"	19"	4,600	20,000	20,000
					8"		4,800		
					9"		5,450		
					10"		6,100		
					11"		6,800		
12 Ton x 12.56"	12.56"	4.76"	4.0"	3.2"	7.5"	19"	4,600	23,450	23,450
					8"		4,800		
					9"		5,450		
					10"		6,100		
					11"		6,800		
12"	7,600								

Safe Working Load provides a factor of safety approximately 4 to 1 in 3,500 psi normal weight concrete. Anchors were tested in concrete with minimum reinforcing per ACI 318

P92FEWDP Forged Erection Anchor with Shear Plate and Secondary Shear Pin

The P92FEWDP Forged Erection Anchor with Shear Plate is specifically designed to provide greater lifting capacities for horizontal to vertical edge lifts. By welding a solid shear pin opposite the shear plate, the anchor can resist shear loads in both directions. The anchors are forged to provide 20% greater safe working loads. The P92FEWDP eliminates the need for a shear bar on the primary and secondary shear loading.



Due to the anchor being forged, it does not depend on welds or thread engagement to develop its safe working load. Forging provides maximum safety with its advantageous material structure. This allows the anchor to easily meet the OSHA requirement of 4 to 1 factor of safety.

P92FEWDP	Product Code (Plain)	Product Code (Galvanized)
3 Ton	142881	MTO
6 Ton	142882	MTO
10 Ton	142883	MTO
12 Ton	100155	MTO

PRODUCT APPLICATION:

The P92FEWDP Forged Erection Anchor with Shear Plate and Secondary Shear Pin is designed specifically for edge tilting precast concrete elements from the horizontal to vertical position. When the panel is placed on an "A" frame or is required to be rotated 180°, the addition of the shear pin works with the shear plate to resist the shear load in the opposite direction of the shear plate. The shear pin helps to protect the concrete from spalling when the shear loads are applied in a secondary direction.

PRODUCT FEATURES AND BENEFITS:

The P92FEWDP has two steel protrusions or "ears" at the head of the anchor which provides protection against concrete spalling. These "ears" restrict the ring clutch rotation during lateral pulls. As a result, lateral forces are transmitted directly to the edge of the anchor instead of the concrete.

The P92FEWDP Forged Erection Anchor utilizes the Fleet P91S or Fleet P91NC lifting hardware and the P99 Recess Plugs.

The P92FEWDP Forged erection Anchors are available in a plain finish.

INSTALLATION:

The P92FEWDP anchor is set in the form with the shear plate in the down position to resist the primary shear load.

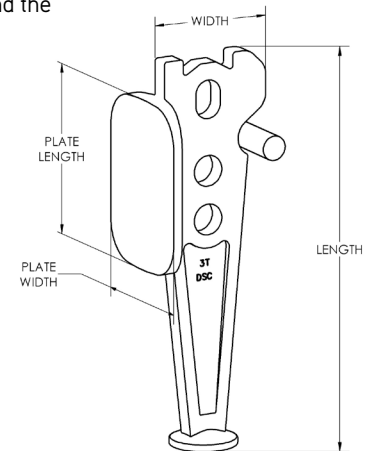

To Order:

Specify: (1) quantity, (2) name, (3) product code, (4) finish.

Example:

200, P92FEWDP 3-Ton 8" Fleet-Lift Forged Erection Anchor with Shear Plate and Secondary Shear Pin, 142881, plain finish.

P92FEWDP Forged Erection Anchor (Ton x Length)	Product Code	Slab Thickness	Shear Safe Working Load Primary Shear	Shear Safe Working Load Secondary Shear	Tension Safe Working Load Anchor Only	Tension Safe Working Load with Tension Bar
3 Ton x 8"	142881	4"	1,800 lbs	1,390 lbs	6,000 lbs	6,000 lbs
		8"	4,000 lbs	3,000 lbs		
		12"	5,700 lbs	4,425 lbs		
6 Ton x 10-3/8"	142882	5-1/2"	3,100 lbs	2,560 lbs	10,000 lbs	12,000 lbs
		8"	4,040 lbs	3,660 lbs	12,000 lbs	
		12"	6,100 lbs	5,600 lbs	12,000 lbs	
10 Ton x 12-3/4"	142883	7-1/2"	4,600 lbs	3,630 lbs	17,890 lbs	20,000 lbs
		10"	6,100 lbs	4,900 lbs	20,000 lbs	
		12"	7,600 lbs	6,520 lbs	20,000 lbs	
12 Ton x 12-3/4"	100155	7-1/2"	4,600 lbs	3,630 lbs	17,890 lbs	23,450 lbs
		10"	6,100 lbs	4,900 lbs	20,695 lbs	
		12"	7,600 lbs	6,520 lbs	22,565 lbs	

Safe working load provides a factor of safety approximately 4 to 1 in 3500 psi normal weight concrete
Anchors were tested in concrete with minimum reinforcing per ACI 318

P92H Fleet-Lift™ Two-Hole Erection Anchor P92HP Fleet-Lift™ Two-Hole Erection Anchor with Shear Plate

Fleet-Lift Two-Hole Erection Anchors combine the strength, spall resistance and high tension performance of the P92 Erection Anchor.

The P92H Two-Hole Erection Anchor was designed for use where the lift direction applies a tension load ONLY to the anchor. A properly installed P98T Tension Bar is always required when using this erection anchor. For shear applications the P98S Shear Bar is designed to fit over the P92H. The design of the shear bar allows it to fit over the top edge of the anchor. It is placed in the top notch and secured so that it bears tightly against the bottom of the notch. Accurate placement of the shear bar provides for spall-free edge lifting.

The P92HP Two-Hole Erection Anchor was designed for use where the lift direction applies both a shear and tension load to the anchor. As with the P92H anchor, a properly installed P98T Tension Bar is always required when using the P92HP Erection Anchor. Shear loading for this anchor is resisted by the P92HP anchor's integral shear plate.

Both the P92H and P92HP Erection Anchors are available in 2, 4, 6 or 8-ton capacities. In addition, they are available in either plain or hot-dipped galvanized finish.

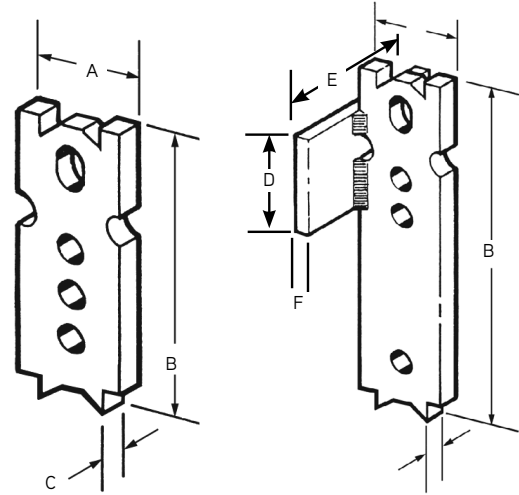

P92H Fleet-Lift Two-Hole Erection Anchor (Tension Loadings ONLY)
P92HP Fleet-Lift Two-Hole Erection Anchor with Shear Plate (Shear and Tension Loading)

Fleet-Lift™ System

To Order:

Specify: (1) quantity, (2) name, (3) product code, (4) corrosion resistance, if required.

Example:

200, P92H Fleet-Lift Two-Hole Erection Anchor, FL075, hot-dipped galvanized.

P92H Fleet-Lift Two-Hole Erection Anchor (ton x length)	Product Code	A	B	C
2-ton x 4-1/4" long	FL403	2"	4-1/4"	3/8"
2-ton x 8-1/4" long	FL903	2"	8-1/4"	3/8"
4-ton x 7-7/8" long	FL075	2-1/2"	7-7/8"	5/8"
4-ton x 10-7/8" long	FL975	2-1/2"	10-7/8"	5/8"
8-ton x 13-1/4" long	FL185L	3-3/4"	13-1/4"	3/4"

P92HP Fleet-Lift Two-Hole Erection Anchor with Shear plate (ton x length)	Product Code	D	E	F
2-ton x 4-1/4" long	FL423	2-1/2"	3"	1/4"
2-ton x 8-1/4" long	FL403L	2-1/2"	3"	1/4"
4-ton x 7-7/8" long	FL275	2-1/2"	3"	3/8"
4-ton x 10-7/8" long	FL175L	2-1/2"	3"	3/8"
8-ton x 13-1/4" long	FL285L	3"	3-1/2"	3/8"

Anchor dimensions not shown are the same as the P92 Erection Anchor of the same load range.

Shear Reinforcement

Stress is caused during the edge lifting of a precast concrete panel, making supplemental reinforcement around the anchor necessary in thin panels. The Fleet-Lift P92HP Erection Anchor with integral Shear Plate is designed expressly for this purpose. Install the anchor so that the shear plate is opposite the direction of lift.

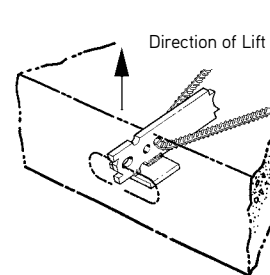

Typical P92HP Fleet-Lift Two-Hole Erection Anchor with Shear Plate Application

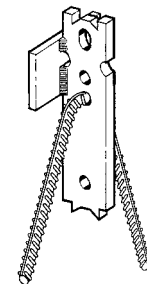

Typical P92HP Fleet-Lift Two-Hole Erection Anchor with Shear Plate/Tension Bar Application

Tension Reinforcement

The P92HP Fleet-Lift Erection Anchor with Shear Plate must be properly reinforced using the P98T Tension Bar. The tension bar should be placed through the lower hole.

P92H Fleet-Lift Two-Hole Erection Anchor and P92HP Fleet-Lift Two-Hole Erection Anchor with Shear Plate Capacities

Fleet-Lift™ System

Ton x Length	A	B	C	D	E	F	Precast Concrete Panel Thickness	P92HP w/ Shear Plate SWL (lbs)	P92H or P92HP w/ Tension Bar Tension SWL (lbs)
2-ton x 4-1/4" long	2"	4-1/4"	3/8"	2-1/2"	3"	1/4"	3-1/2" Min	1,325	4,000
							4"	1,525	
							5"	1,525	
							6"	1,750	
							7"	1,900	
							8"	2,075	
2-ton x 8-1/4" long	2"	8-1/4"	3/8"	2-1/2"	3"	1/4"	4" Min	1,650	
							5"	1,875	
							6"	2,125	
							7"	2,400	
							8"	2,700	
							9"	2,925	
							10"	3,275	
11"	3,575								
12"	3,975								
4-ton x 7-7/8" long	2-1/2"	7-7/8"	5/8"	2-1/2"	3"	3/8"	5-1/2" Min	2,025	8,000
							6"	2,250	
							7"	2,600	
							8"	3,000	
							9"	3,375	
4-ton x 10-7/8" long	2-1/2"	10-7/8"	5/8"	2-1/2"	3"	3/8"	4" Min	2,150	
							5"	2,625	
							6"	3,100	
							7"	3,525	
							8"	3,925	
							9"	4,275	
							10"	4,600	
							11"	4,900	
12"	5,150								
8-ton x 13-1/4" long	3-3/4"	13-1/4"	3/4"	3"	3-1/2"	3/8"	6" Min	4,000	16,000
							7"	4,250	
							8"	4,475	
							9"	4,725	
							10"	4,950	
							11"	5,200	
12"	5,450								

Notes:

1. Safe Working Load provides an approximate factor of safety of 4 to 1 in 3,500 psi normal weight concrete.
2. Dayton Superior recommends the use of the P92HP Fleet-Lift Anchor when shear loads will be encountered.

P92FEH Fleet-Lift™ Forged Erection Anchor

The P92 FEH Forged Erection Anchor is specifically designed to provide greater lifting capacities as related to stamped anchors. The anchors are forged to provide 30% greater safe working loads. The P92 FEH uses a tension bar to achieve the required loads.

Because the anchor is forged, it does not depend on welds or thread engagement to develop its safe working load. Forging provides an advantageous material structure that allows increased strength. This allows the anchor to easily meet the OSHA requirement of 4 to 1 factor of safety.



Application

The P92FEH Forged Erection Anchor is designed specifically for applications where a high-performance anchor is required for tension loads ONLY. A properly installed P98T Tension Bar is always required when using this anchor. For shear applications, the P98S Shear Bar fits over the top edge of the P92FEH Anchor. It is placed in the top notch and secured so the it bears tightly against the bottom of the notch. Accurate placement of the shear bar provides spall-free edge lifting.

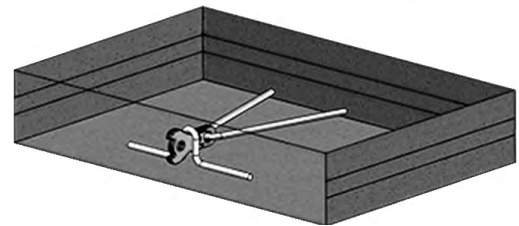

Fleet-Lift™ System

Features

- The P2FEH has two steel protrusions (or "ears") at the head of the anchor protect against concrete spalling. They restrict the ring clutch rotation during lateral pulls. As a result, lateral forces are transmitted directly to the edge of the anchor instead of the concrete.
- The P92FEH Forged Erection Anchor utilizes the Fleet-Lift P91S or P91NC lifting hardware and the P99 Recess Plugs
- P92FEH Forged Erection Anchors are available in plain or Hot dipped galvanized (special order) finishes.

Product Code	Material	Load Rating	Slab Thickness	Minimum Edge Distance	Minimum Corner Distance	Shear Safe Working Load with Shear Bar	Tension Safe Working Load with Tension Bar
129852	Plain	3 ton	4"	2"	12"	1,650 lbs	6,000 lbs
			5"	2-1/2"		1,875 lbs	
			6"	3"		2,125 lbs	
			7"	3-1/2"		2,400 lbs	
			8"	4"		2,700 lbs	
			9"	4-1/2"		2,925 lbs	
			10"	5"		3,275 lbs	
			11"	5-1/2"		3,575 lbs	
129853	Plain	6 ton	5-1/2"	2-3/4"	16"	2,400 lbs	12,000 lbs
			6"	3"		3,075 lbs	
			7"	3-1/2"		3,250 lbs	
			8"	4"		3,425 lbs	
			9"	4-1/2"		3,825 lbs	
			10"	5"		4,250 lbs	
			11"	5-1/2"		4,650 lbs	
			12"	6"		5,050 lbs	
129854	Plain	10 ton	7-1/2"	3-3/4"	19"	4,000 lbs	20,000 lbs
			8"	4"		4,200 lbs	
			9"	4-1/2"		4,550 lbs	
			10"	5"		4,950 lbs	
			11"	5-1/2"		5,050 lbs	
			12"	6"		5,175 lbs	

Safe Working Load provides a Safety factor of approximately 4 to 1 in 3,500 psi normal weight concrete.

P92S Fleet-Lift™ Sandwich Panel Erection Anchor P92SP Fleet-Lift™ Sandwich Panel Erection Anchor with Shear Plate

The Fleet-Lift Sandwich Panel Erection Anchor is designed to erect precast, insulated sandwich panels with a minimum loss of insulation. The anchor uses standard Fleet-Lift recess plugs and ring clutches.

The P92S Sandwich Panel Erection Anchor is designed for use with 2", 3" and 4" thick insulated sandwich panels.

The design of the anchor allows it to distribute anchor loads evenly to both concrete wythes. This is accomplished by the use of two specially bent rebars per sandwich panel anchor. The sandwich panel erection anchor, with its unique anchor head shape, in combination with the two bent rebars, transfers both the anchor's shear and tension loads evenly into each of the concrete wythes.

Place one bent rebar through the anchor's top hole and the second rebar through the anchor's bottom hole. The rebar extend from the anchor into the top and bottom wythe of concrete. The two specially bent rebar must be used with the sandwich panel erection anchor to achieve the safe working loads shown.

The P92SP Sandwich Panel Erection Anchor is similar in design and action to the P92S anchor, and has a built-in shear plate. The shear plate improves shear capacity when used in the 2", 3" and 4" thick wythes.

Both the P92S and P92SP anchors are available in plain or hot-dipped galvanized finish.

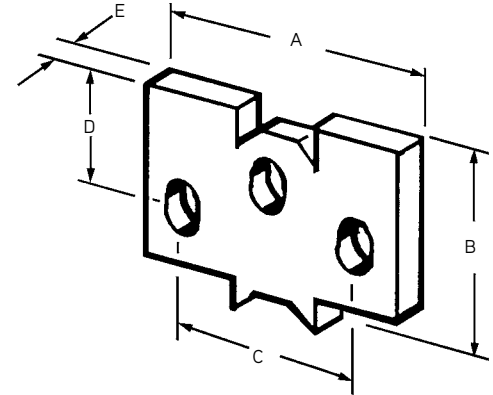

P92S Fleet-Lift Sandwich Panel Erection Anchor

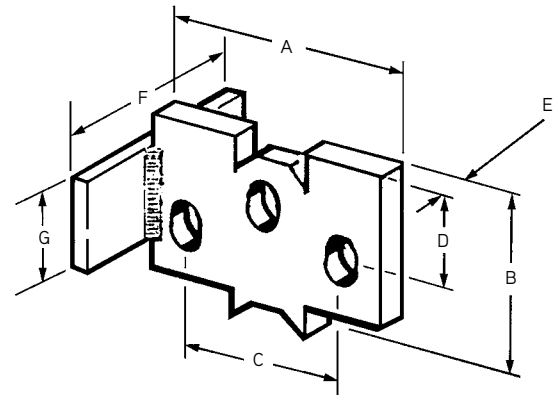

P92SP Sandwich Panel Erection Anchor with Shear Plate

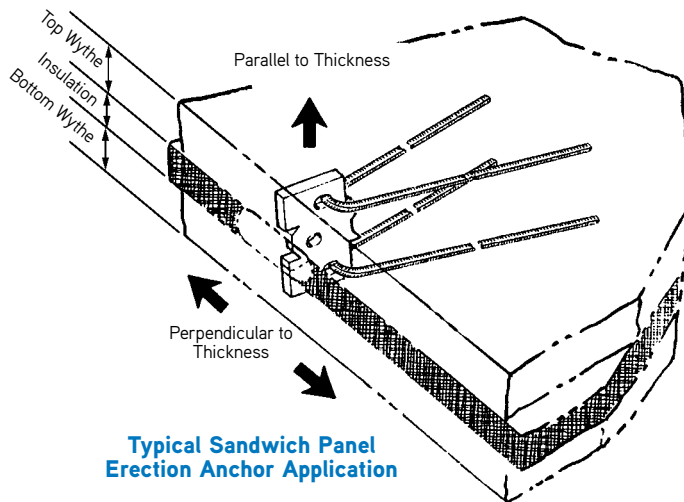

Typical Sandwich Panel Erection Anchor Application

To Order:

Specify: (1) quantity, (2) name, (3) product code, (4) finish.

Example:

200, P92S Fleet-Lift Sandwich Panel Erection Anchor, FL077, hot-dipped galvanized.

Anchor Tonnage	Product Code	Shear Plate	A	B	C	D	E	F	G
4-ton	FL077	No	6"	3-3/4"	4-3/8"	1-13/16"	5/8"	-	-
	FL230	Yes	6"	3-3/4"	4-3/8"	1-13/16"	5/8"	3"	2"
8-ton	FL184	No	6"	4-3/4"	4"	3-3/8"	3/4"	-	-
	FL284G	Yes	6"	4-3/4"	4"	3-3/8"	3/4"	3"	3-1/2"
10-ton	145569	Yes	7"	4-3/4"	5"	3-3/8"	3/4"	-	-
	145570	Yes	8"	4-3/4"	6"	3-3/8"	3/4"	-	-

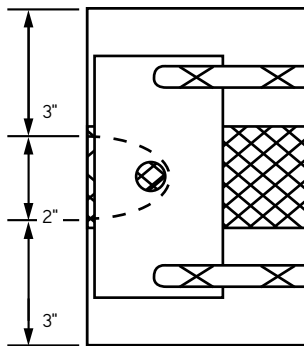

3" x 2" x 3" Panel

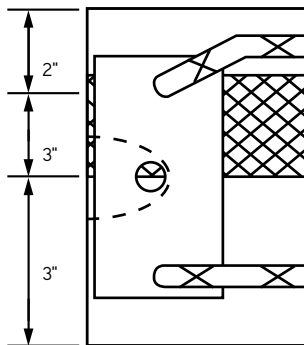
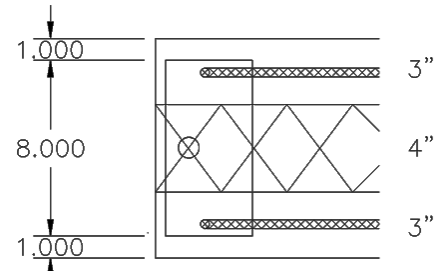
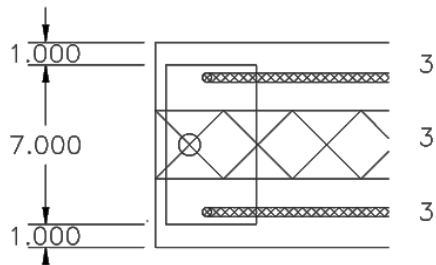

2" x 3" x 3" Panel

Fleet Lift Sandwich Panel Erection Anchor Safe Working Loads

Anchor Tonnage	For Anchor	Concrete	Insulated Panel Thickness	Shear Parallel to Thickness 4:1 SF	Shear Parallel to Thickness 2.66:1 SF	Shear	Tension
4-ton	FL077	4,500 psi	2" x 2" x 4"	3,300 lbs	4,960 lbs	8,000 lbs	8,000 lbs
		3,500 psi	3" x 2" x 3"	3,425 lbs	5,150 lbs	8,000 lbs	
8-ton	FL184	4,500 psi	3" x 2" x 3"	3,850 lbs	5,785 lbs	9,900 lbs	16,000 lbs
		4,500 psi	2" x 2" x 4"	3,450 lbs	5,185 lbs	10,500 lbs	
8-ton	FL284	4,500 psi	4" x 2" x 2"	4600 lbs	6,915 lbs	9,870 lbs	16,000 lbs
		4,500 psi	3" x 2" x 3"	4,400 lbs	6,915 lbs	8,800 lbs	
10-ton	145569	4,500 psi	3" x 3" x 3"	4,700 lbs	7,065 lbs	10,900 lbs	20,000 lbs
	145570	4,500 psi	3" x 4" x 3"	4,400 lbs	6,615 lbs	9,200 lbs	

Minimum edge distance is 2'-0"
Must use proper tension bar to achieve loads

P92SF Fleet-Lift™ Sandwich Panel Erection Anchor

The P92SF Fleet-Lift Sandwich Panel Erection Anchor (Patent #5,857,296) is designed to erect precast insulated sandwich panels with a minimum loss of insulation. The P92SF Sandwich Panel Erection Anchor is designed for use with the most common insulation thickness. The head of the anchor is designed with two protrusions on the head of the anchor which provide protection against concrete spalling. These protrusions restrict the ring clutch rotation during lateral pulls. As a result, lateral forces are transmitted directly to the edge of the anchor instead of the concrete. The design of the anchor allows it to distribute anchor loads evenly to both concrete wythes. This is accomplished by the use of two Tension Bars placed through the holes at the end of the anchor.

Due to the anchor being forged, it does not depend on welds or thread engagement to develop its safe working load. Forging provides maximum safety with its advantageous material structure. This allows the anchor to easily meet the OSHA requirement of 4 to 1 factor of safety.

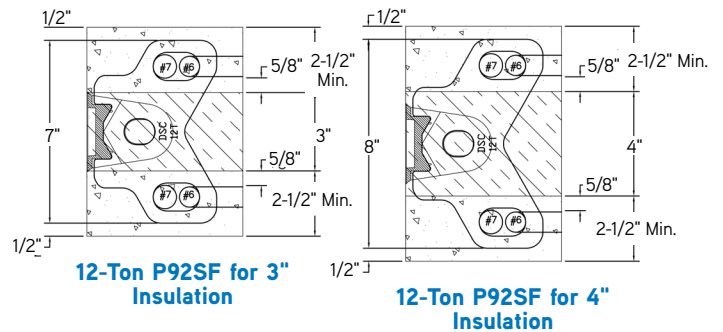
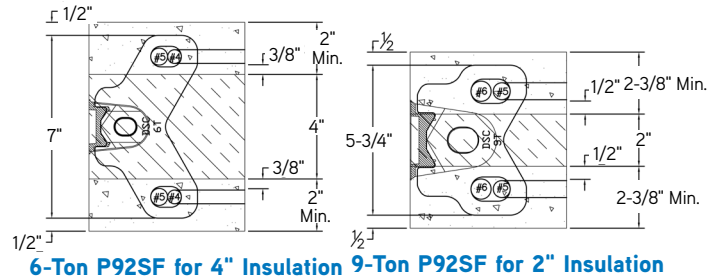

Application

The P92SF is installed in concrete for tension and shear lifting applications.

Features

- Forged design creates up to 33% higher load capacity than stamped anchors which can reduce the number of anchors required.
- Plain or galvanized finishes available. Meets non-rusting requirements.
- Forged material minimizes rust and can result in eliminating galvanizing requirement for some projects.
- Design eliminates steel near top edge of face of panel, reducing opportunity for cracks occurring.
- Two Tension Bars must be used with the Sandwich Panel Erection Anchor to achieve the Safe Working Loads shown.

Technical Data

Product Code		Anchor Tonnage	Anchor Length	Concrete Compressive Strength	Insulated Panel Thicknesses	Shear Parallel to Thickness 4:1 SF	Shear Parallel to Thickness 2.66:1 SF	Shear Perpendicular to Thickness 4:1 SF	Tension 4:1 SF	Tension Rebar	Shear Rebar
Plain	HDG										
143700	143701	6-ton	7"	3,500 psi	2" x 4" x 2"	2,675 lbs	4,020 lbs	8,200 lbs	12,000 lbs.	#4 x 34" Gr 60	#5 x 6" Gr 60
				3,500 psi	3" x 3" x 3"	4,509 lbs	6,765 lbs	9,600 lbs			
145081	145566	9-ton	5.75"	3,500 psi	3" x 2" x 3"	4,400 lbs	6,615 lbs	8,700 lbs	18,000 lbs.	#5 x 42" Gr 60	#6 x 6" Gr 60
				3,500 psi	4" x 2" x 2"	4,600 lbs	6,915 lbs	9,260 lbs			
145572	145718	12-ton	7"	4,500 psi	3" x 3" x 3"	4,700 lbs	7,065 lbs	10,900 lbs	24,000 lbs.	#6 x 66" Gr 60	#7 x 6" Gr 60
145573	145719		8"	4,500 psi	4" x 4" x 3"	4,400 lbs	6,615 lbs	9,200 lbs			

Installation

1. Place one configured Tension Bar through the holes of the anchor extending from the anchor into the top and bottom wythe of concrete.
2. Place Shear Bars through top of Tension Bar slot next to Tension Bars.

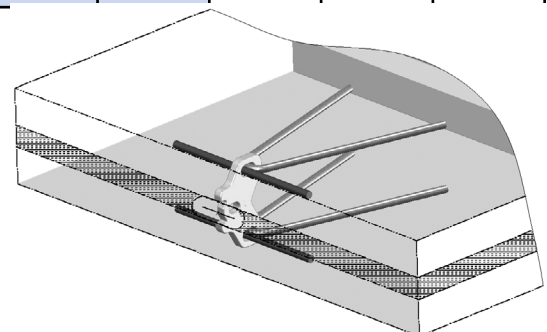

P92T Fleet-Lift™ Sandwich Panel Reinforcing Bars

Anchor Tonnage	Anchor Product Code				Rebar
4-ton	FL077				#4 Grade 60 x 34" overall
6-ton	143700				#4 Grade 60 x 34" overall
8 or 9-ton	FL184	FL284	145081		#5 Grade 60 x 42" overall
10 or 12-ton	145569	145570	145572	45573	#6 Grade 60 x 66" overall

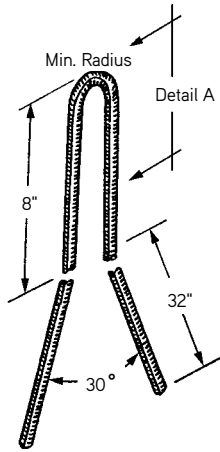

Rebar for 2" x 2" x 2" Panel

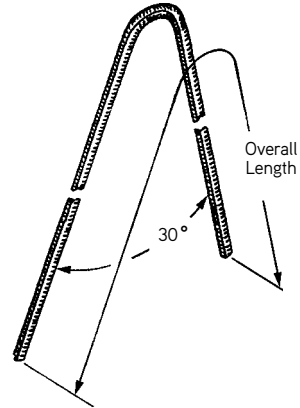
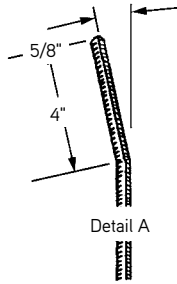

Rebar for 3" x 2" x 3",
2" x 2" x 4", 3" x 3" x 3" and
3" x 4" x 3" Panels

P92AH Fleet-Lift™ Erection Anchor with 45° Head with Shear Plate

The Dayton Superior P92AH Fleet-Lift Erection Anchor with 45° Head and Shear Plate is designed for use when the lifting edge is beveled at a 45° angle. The factory installed shear plate eliminates the need for any additional shear reinforcement.

Installation

To install the P92AH anchor, position the anchor a minimum of 3/4" and a maximum of 1-1/2" clear of the casting bed. This can be accomplished using any of the standard recess members. After the anchor has been secured in place, tension reinforcement may be added, if desired. After the concrete has set, removal of the edge form and recess member will expose the head of the anchor for easy attachment of the lifting eye.

Tension Reinforcement

Due to the geometry of the anchor the loads shown in the table should not be exceeded, even if additional tension reinforcement is present.

P92AH Erection Anchors are available plain, or hot-dipped galvanized.

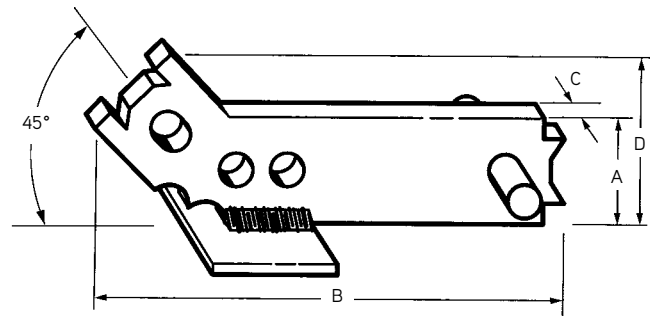

P92AH Fleet-Lift Erection Anchor with 45° Head with Shear Plate

To Order:

Specify: (1) quantity, (2) name, (3) product code, (4) corrosion resistance, if required.

Example:

200, P92AH, Fleet-Lift Erection Anchor with 45° head, FL454, hot-dipped galvanized.

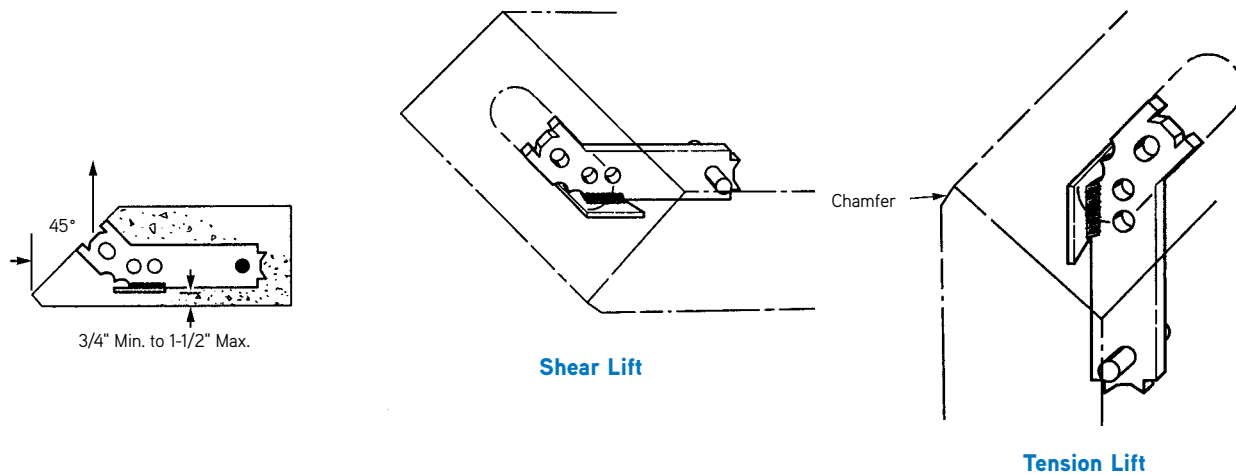

P92AH Fleet-Lift Erection Anchor (ton x length)	Product Code	Precast Concrete Panel Thickness	Shear Safe Working Load for Shear	Tension Safe Working Load Anchor Only	Tension Safe Working Load with Tension Bar	A	B	C	D
2-ton x 8-1/2" long	FL452	5" Min.	1,750 lbs.	2,650 lbs.	2,650 lbs.	2"	8-1/2"	3/8"	3-1/2"
		6"	2,150 lbs.	3,850 lbs.	3,850 lbs.				
4-ton x 11" long	FL454	6" Min.	2,400 lbs.	5,200 lbs.	5,200 lbs.	2-1/2"	11"	5/8"	4"
		8"	3,500 lbs.	6,200 lbs.	6,200 lbs.				
8-ton x 13-3/4" long	FL458	8" Min.	3,500 lbs.	7,500 lbs.	7,500 lbs.	3-3/4"	13-3/4"	3/4"	5-3/8"

Notes:

Safe Working Load provides an approximate factor of safety of 4 to 1 in 3,500 psi normal weight concrete. Safe Working Load is based on the anchor being located in the panel so that the shear plate is 3/4" minimum to 1-1/2" maximum from casting surface. Panel will not hang plumb, as the panel thickness, center of gravity and anchor location will determine the exact angle at which the panel will hang. Due to the design of this anchor, DO NOT attempt to use this anchor at loads higher than shown in this table - even with a properly installed tension bar. Anchor dimensions not shown are the same as the P92P Erection Anchor with Shear Plate of the same load range.

P93 Fleet-Lift™ L-Anchor

The Dayton Superior P93 Fleet-Lift L-Anchor is a very efficient anchor. This anchor is used for both stripping and erection carrying tension and/or shear loads (except for edge shear in thin panels). The L-Anchor produces exceptionally high pullout strength for its size, due to its foot design.

The L-Anchor can be placed on the face, back, or thicker panel edge allowing for back-stripping and their rotation from horizontal to vertical.

The P93 anchor is available in plain or hot-dipped galvanized finish. This anchor requires the use of the 2/5-ton range ring clutch and the 2/3-ton load range recess plug.

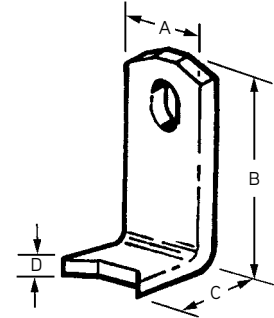

P93 Fleet-Lift L-Anchor

To Order:

Specify: (1) quantity, (2) name, (3) product code, (4) finish.

Example:

200 P93 Fleet-Lift L-Anchor, FL050, hot-dipped finish.

P93 Fleet-Lift L-Anchor (ton x length)	Product Code	Precast Concrete Panel Thickness	Minimum Edge or Corner Distance	Shear Safe Working Load for Shear	Tension Safe Working Load Anchor Only	A	B	C	D
1-ton x 4" long	FL050	5" Min.	12"	2,000 lbs.	2,000 lbs.	1-1/4"	4"	1-7/16"	3/16"

Notes:

Safe Working Load provides an approximate factor of safety of 4 to 1 in 3,500 psi normal weight concrete.

Anchor is not designed for use in thin edge shear conditions.

Anchor must use FL051 (P99) Reusable Recess Plug

P94 Fleet-Lift T-Anchor

The P94 Fleet-Lift T-Anchor is a versatile anchor available in many sizes and lengths. Its high pullout strength allows it to be used for back-stripping and erection. T-Anchors can be placed on the face, back or edge of panels allowing for back-stripping and rotation from horizontal to vertical.

P94 anchors are available in plain or hot-dipped galvanized finish.

To Order:

Specify: (1) quantity, (2) name, (3) product code, (4) finish.

Example:

200, P94 Fleet-Lift T-Anchors, FL850, hot-dipped galvanized.

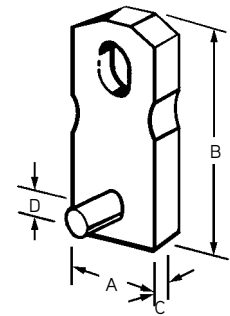

P94 Fleet-Lift T-Anchor 4-ton

P94 Fleet-Lift L-Anchor (ton x length)	Product Code	Min. Precast Concrete Panel Thickness	Minimum Edge or Corner Distance	Shear Safe Working Load	Tension Safe Working Load	A	B	C	D
2-ton x 4" long	FL110	4-3/4"	8"	4,000 lbs.	4,000 lbs.	1-1/4"	4"	3/8"	1/2"
2-ton x 5-1/2" long	FL059	5-7/8"	11"	4,000 lbs.	4,000 lbs.	1-1/4"	5-1/2"	3/8"	1/2"
4-ton x 4-1/4" long	FL848	4-5/8"	8-1/2"	5,500 lbs.	5,500 lbs.	1-1/2"	4-1/4"	5/8"	1/2"
4-ton x 4-3/4" long	FL849	5-1/8"	9-1/2"	7,100 lbs.	7,100 lbs.	1-1/2"	4-3/4"	5/8"	1/2"
4-ton x 5-1/4" long	FL850	5-5/8"	10-1/2"	8,000 lbs.	8,000 lbs.	1-1/2"	5-1/4"	5/8"	1/2"
4-ton x 5-3/4" long	FL851	6-1/8"	11-1/2"	8,000 lbs.	8,000 lbs.	1-1/2"	5-3/4"	5/8"	1/2"
4-ton x 6-1/4" long	FL852	6-5/8"	12-1/2"	8,000 lbs.	8,000 lbs.	1-1/2"	6-1/4"	5/8"	1/2"
4-ton x 6-3/4" long	FL853	7-1/8"	13-1/2"	8,000 lbs.	8,000 lbs.	1-1/2"	6-3/4"	5/8"	1/2"
4-ton x 7-1/4" long	FL854	7-5/8"	14-1/2"	8,000 lbs.	8,000 lbs.	1-1/2"	7-1/4"	5/8"	1/2"
4-ton x 7-3/4" long	FL855	8-1/8"	15-1/2"	8,000 lbs.	8,000 lbs.	1-1/2"	7-3/4"	5/8"	1/2"
6-ton x 11-1/8" long	FL319*	11-1/2"	23"	12,000 lbs.	12,000 lbs.	2-1/2"	11-1/8"	5/8"	3/4"
8-ton x 6-1/8" long	FL055	6-1/8"	12-1/4"	7,950 lbs.	7,950 lbs.	2-1/2"	6-1/8"	3/4"	3/4"
8-ton x 11-1/8" long	FL119	11-3/4"	23"	16,000 lbs.	16,000 lbs.	2-1/2"	11-1/8"	3/4"	3/4"

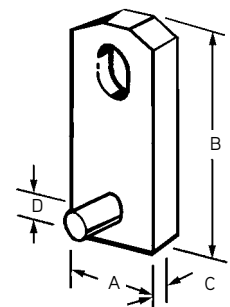

P94 Fleet-Lift T-Anchor 2, 6 and 8-ton

Safe Working Load provides a factor of safety of approximately 4 to 1 in 3,500 psi normal weight concrete.

Side notches are provided on 4-ton T-Anchors only.

No side notches are provided on 2, 6 and 8-ton T-Anchors.

Use 8-10T P99 Recess and P91 Ring Clutch with FL319*.

P94H Fleet-Lift™ H-Anchor 2-Ton

The Dayton Superior Fleet-Lift H-Anchor (P94H) is unique in design simplicity. It offers exceptional strength for lifting and handling precast elements, yet can be used in panels as thin as 3". The P94H anchor can be easily preset in the form or "wet set" after the concrete has been poured. The H-Anchor is the strongest and most economical precast lifting anchor available for back-stripping. H-Anchors are available in plain and hot-dipped galvanized finish.

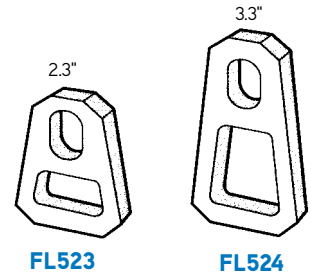

Fleet-Lift™ System

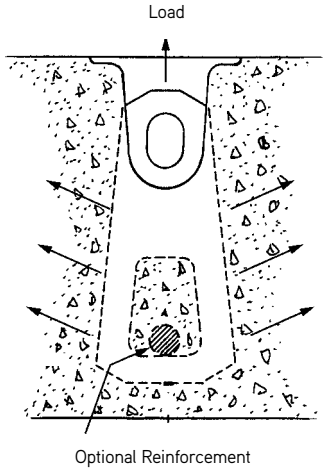

To Order:
Specify: (1) quantity, (2) name, (3) product code, (4) corrosion resistance, if required.

Example:
200, P94H Fleet-Lift H-Anchor, FL525, hot-dipped galvanized.

P94H Safe Working Load

Product Code	Load Range	Tension Load 4:1 SF	Tension with Reinforcement** 4:1 SF	Shear Load 4:1 SF	Minimum Edge Distance	Ultimate Mechanical Strength
FL523	2-ton	2,205 lbs.	2,900 lbs.	2,205 lbs.	8"	16,000 lbs.
FL524	2-ton	3,255 lbs.	4,000 lbs.	3,255 lbs.	10"	16,000 lbs.

Safe Working Load provides a factor of safety of approximately 4 to 1. Table is based on a minimum concrete compressive strength of 3,500 psi.

* When panel edge installation is required, use the H-Anchor or Two-Hole Anchor with a tension bar. Contact Dayton Superior Technical Assistance for minimum tension reinforcement.

** #4 x 12" long placed directly at centerline and against bottom of hole. See sketches at left.

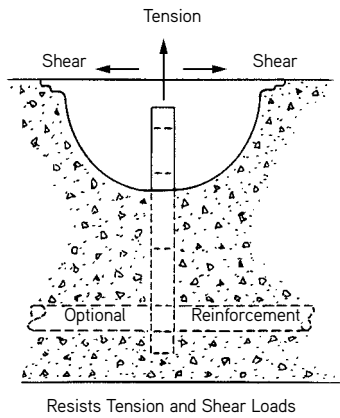

P94H Dimensions 2/3 Ton Ring Clutch System (2-Ton Anchor)

Product Code	A	B	C	D	Minimum Slab Thickness	Weight Each
FL523	1.25"	2.30"	.35"	.56"	3"	.28 lbs.
FL524	1.25"	3.30"	.38"	1.44"	4"	.36 lbs.

P94H H-Anchors are available in plain and hot-dipped galvanized.

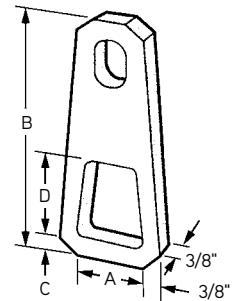

P94S Fleet-Lift™ S-Anchor

The Dayton Superior P94S Fleet-Lift S-Anchor is a high-strength, hot forged anchor that can be “wet set” or used with the optional T41 Plastic base in face-lift applications. When the P94S anchor is used with the Fleet-Lift high capacity ring clutches, safe working loads up to 20,000 pounds can be realized. See the table below for appropriate anchor lengths and concrete compressive strengths.

To Order:
Specify: (1) quantity, (2) name, (3) product code, (4) finish.

Example:
400, P94S Fleet-Lift S-Anchors, FL505 with hot-dipped galvanized finish.

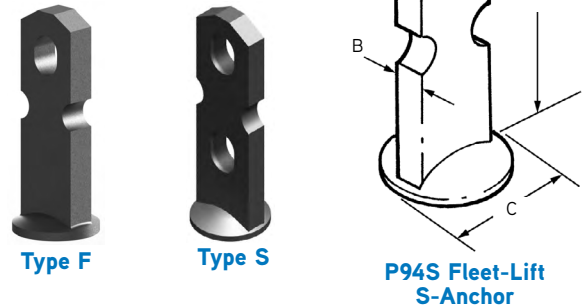

P94S Fleet Lift S-Anchor

Anchor Tonnage	Length (L)	Width (A)	Thickness (B)	Foot Diameter (C)	SWL Tension / Shear
2.5	3-1/2"	1-5/16"	3/8"	1-1/2"	3,900 lbs.
	4"				4,400 lbs.
6	3-7/8"	1-1/2"	5/8"	1-7/8"	5,000 lbs.
	4-1/8"				5,370 lbs.
	4-7/8"				6,560 lbs.
	5-1/8"				6,970 lbs.
	5-7/8"				8,250 lbs.
	6-7/8"				10,070 lbs.
10	7"	2-5/8"	3/4"	2-7/8"	12,500 lbs.

Safe working load is based on an approximate factor of safety of 4 to 1 in 3,500 psi normal weight concrete
Minimum edge distance is 1.5 × the anchor length.

P95F Fleet-Lift™ Flat Foot Anchor

The Dayton Superior P95F Fleet-Lift Flat Foot Anchor is a versatile anchor that can be used to back-strip and transport thin panels. This anchor may also be used to erect the panels.

The anchor’s safe working load may be increased by adding four 18" lengths of #4 rebar as shown in the illustration.

To Order:
Specify: (1) quantity, (2) name, (3) product code.

Example:
200, P94F Fleet-Lift Flat Foot Anchor, FL058.

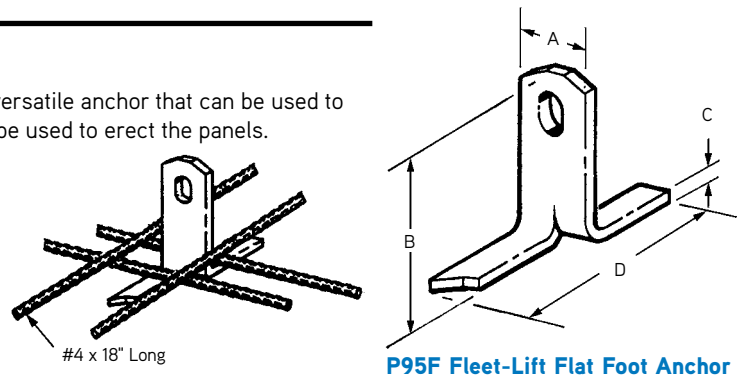

P95F Fleet-Lift Flat Foot Anchor (ton x length)	Product Code	Precast Concrete Min. Panel Thickness	Minimum Edge or Corner Distance	Shear Safe Working Load	Tension Safe Working Load	Shear Safe Working Load Reinforced	Tension Safe Working Load Reinforced	A	B	C	D
2-ton x 2-3/4" long	FL058	3-7/8"	5-1/2"	1,325 lbs.	1,325 lbs.	4,000 lbs.	4,000 lbs.	1-1/4"	2-3/4"	3/8"	4"
2-ton x 3-3/8" long	FL400	4-1/2"	6-3/4"	1,875 lbs.	1,875 lbs.	4,000 lbs.	4,000 lbs.	1-1/4"	3-3/8"	3/8"	4"
3-ton x 3-3/4" long	FL157	4-7/8"	7-1/2"	2,350 lbs.	2,350 lbs.	6,000 lbs.	6,000 lbs.	1-1/2"	3-3/4"	1/2"	4"

Safe working load is based on an approximate factor of safety of 4 to 1 in 3,500 psi normal weight concrete.
NOTE: A minimum 3/4" concrete cover below the anchor is required to achieve posted working loads.

P95P Fleet-Lift™ Plate Anchor

The Dayton Superior P95P Fleet-Lift Plate Anchor is manufactured with a wide base designed to increase its pull-out capacity in concrete. The wide base allows the anchor to have an increased safe working load.

The design of the anchor, with its wide base, permits four #4 rebar, each 18" in length to be easily secured to the insert, as illustrated in the sketch. The addition of the rebar increases the safe working load the anchor.

P95P anchors are available in plain or hot-dipped galvanized finish.

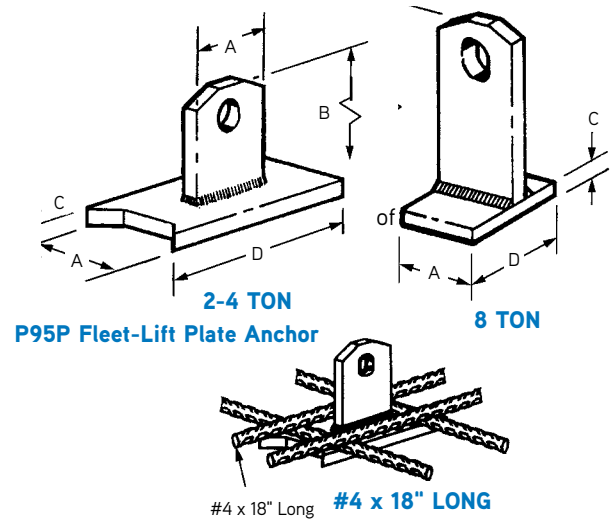

Fleet-Lift™ System

To Order:

Specify: (1) quantity, (2) name, (3) product code, (4) corrosion resistance, if required.

Example:

200, P95P Fleet-Lift Plate Anchor, FL847.

P95P Fleet-Lift Plate Anchor (ton x length)	Product Code	Precast Concrete Minimum Panel Thickness	Minimum Edge or Corner Distance	Shear Safe Working Load	Tension Safe Working Load	Shear Safe Working Load Reinforced	Tension Safe Working Load Reinforced	A	B	C	D
2-ton x 2-1/4" long	FL128	3-3/8"	4-1/2"	950 lbs.	950 lbs.	4,000 lbs.	4,000 lbs.	1-1/4"	2-1/4"	3/8"	4"
4-ton x 3" long	FL846	4-5/8"	5"	3,575 lbs.	3,575 lbs.	6,000 lbs.	6,000 lbs.	1-1/2"	3"	5/8"	3-3/8"
4-ton x 3-1/2" long	FL847	4-5/8"	7"	4,700 lbs.	4,700 lbs.	7,000 lbs.	7,000 lbs.	1-1/2"	3-1/2"	5/8"	3-3/8"
4-ton x 4-3/8" long	FL044	5-5/8"	8"	4,725 lbs.	4,725 lbs.	8,000 lbs.	8,000 lbs.	1-1/2"	4-3/8"	5/8"	4"
8-ton x 6-7/8" long	FL043	8-1/4"	13-5/8"	10,850 lbs.	10,850 lbs.	11,750 lbs.	11,750 lbs.	2-1/2"	6-7/8"	3/4"	3"

Safe Working Load provides an approximate factor of safety of 4 to 1 in 3,500 psi normal weight concrete. A minimum 3/4" of concrete is required below bottom of insert to achieve load.

P96 Fleet-Lift™ Two-Hole Anchor

The Dayton Superior P96 Fleet-Lift Two-Hole Anchor is always used in conjunction with the Dayton Superior P98T Tension Bar. The anchor has a bottom hole especially designed to accept the tension bar. Place the P98T Tension Bar through the bottom hole in such a manner that the ends of the tension bar are pointing downward. Fasten the tension bar tight against the bottom side of the hole.

The tension bar distributes the tension forces, developed from the lifting process, deep into the precast concrete. This allows the lifting of very thin and/or low concrete compressive strength panels.

Do not use the P96 Two-Hole Anchor in the following situations:

To Order:

Specify: (1) quantity, (2) name, (3) product code, (4) corrosion resistance, if required. See P98T Fleet-Lift Tension Bar.

Example:

200, P96 Fleet-Lift Two-Hole Anchor, FL124.

NOTE: Tension reinforcement must be used with Two Hole Anchors.

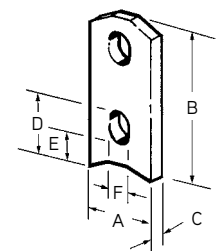

P96 Fleet-Lift Two Hole Anchor

- Without a correct size and located tension bar.
- In the edge of thin panels where shear loads will be applied to the anchor.

P96 Fleet-Lift Two-Hole Anchor (ton x length)	Product Code	Tension Safe Working Load with Tension Bar	A	B	C	D	E	F
2-ton x 2-3/4" long	FL190	4,000 lbs	1-1/4"	2-3/4"	3/8"	9/16"	15/16"	9/16"
2-ton x 4" long	FL122	4,000 lbs	1-1/4"	4"	3/8"	3/4"	7/8"	9/16"
4-ton x 5-1/2" long	FL124	8,000 lbs	1-1/2"	5-1/2"	5/8"	7/8"	1"	11/16"
8-ton x 7" long	FL125	16,000 lbs	2-1/2"	7"	3/4"	1-3/16"	1-1/2"	1"

Safe working load is based on an approximate factor of safety of 4 to 1 in 3,500 psi normal weight concrete.

P140 Forged Foot Anchor

The Dayton Superior P140 Forged Foot Anchor is a face lift high capacity 9 Ton insert. The insert utilizes the P91 Ring Clutch 8-12 T. P140 Steel Anchor can be used with single use T110 Single Use Void Former Half - 126537 (Buy QTY (2) 126537 for each P140 anchor)



Fleet-Lift™ System

To Order:

Specify: (1) quantity, (2) name, (3) Panel Thickness, (4) bottom face exposed aggregate or formliner thickness.

Example:

150, P140 Superior Lift Inserts, 9" Panel.

Note: DO NOT use this anchor with P99D single use void former.

Panel Thickness	Anchor Length	Plain Product Code	HDGALV Product Code	SWL Tension (4:1 SF 3500 PSI)	SWL Shear (4:1 SF 3500 PSI)	SWL Tension (4:1 SF 5000 PSI)	SWL Shear (4:1 SF 5000 PSI)
5"	3-5/8"	100408	100409	6,860 lbs	7,330 lbs	8,199 lbs	8,761 lbs
5.5"	4-1/8"	126538	100411	7,690 lbs	7,920 lbs	9,191 lbs	9,466 lbs
6"	4-5/8"	126539	100412	8,450 lbs	8,750 lbs	10,100 lbs	10,458 lbs
6.25"	4-7/8"	126540	100413	8,790 lbs	9,225 lbs	10,506 lbs	11,026 lbs
6.5"	5-1/8"	126541	100414	9,280 lbs	9,700 lbs	11,092 lbs	11,594 lbs
7"	5-5/8"	126542	100415	10,140 lbs	10,640 lbs	12,120 lbs	12,717 lbs
7.25"	5-7/8"	126543	100416	10,600 lbs	11,120 lbs	12,669 lbs	13,291 lbs
7.5"	6-1/8"	126544	100417	11,050 lbs	11,590 lbs	13,207 lbs	13,853 lbs
8"	6-5/8"	126545	100418	11,950 lbs	12,390 lbs	14,283 lbs	14,809 lbs
8.25"	6-7/8"	126546	100419	12,420 lbs	12,515 lbs	14,845 lbs	14,958 lbs
8.5"	7-1/8"	126547	100420	12,850 lbs	12,640 lbs	15,359 lbs	15,108 lbs
9"	7-5/8"	126548	100421	13,750 lbs	13,530 lbs	16,434 lbs	16,171 lbs
10"	7-7/8"	126549	100422	16,420 lbs	13,590 lbs	18,000 lbs	16,243 lbs

P140 Forged Foot Anchor

Safe Working Load in 3,500 psi normal weight concrete

T275 Tilt-Up Anchor

The Dayton Superior T275 Tilt Up Anchor consists of a dual forged foot anchor assembled with a plastic recess plug and two plastic supports. The insert is a directional insert used parallel to the height of the panel. The T275 inserts are shipped assembled, ready to install and sized to the panel thickness.



T275 Tilt-Up Anchor

Concrete Strength/ Safety Factor	Safe Working Load	Structural Panel Thickness	
		7-1/4" - 9"	9-1/4" - 12"
2,500 psi concrete and 2:1 SF	Tension	20,100 lbs	24,000 lbs
	Shear	24,000 lbs	24,000 lbs
3,000 psi concrete and 2:1 SF	Tension	22,050 lbs	24,000 lbs
	Shear	24,000 lbs	24,000 lbs
3,000 psi concrete and 2.5:1 SF	Tension	24,000 lbs	24,000 lbs
	Shear	17,639 lbs	24,000 lbs
3,000 psi concrete and 4:1 SF	Tension	11,024 lbs	15,718 lbs
	Shear	15,299 lbs	17,250 lbs
4,000 psi concrete and 4:1 SF	Tension	12,731 lbs	16,200 lbs
	Shear	17,250 lbs	17,250 lbs

To Order:
Specify:(1) Quantity, (2) Name, (3) Panel Thickness, (4) Product Code

Example:
150, T275 Tilt-Up Anchors, 7-1/4", 146553

Note: Mechanical Capacity of steel anchor is 69,000 lbs in shear and 64,800 lbs in tension

P98S Fleet-Lift™ Shear Bar

The Dayton Superior P98S Fleet-Lift Shear Bar is designed and manufactured especially for use with Fleet-Lift Erection Anchors. It is a simple, easy to use, yet very efficient design that transfers shear forces from the erection process deeper into the edge of a precast concrete panel. It is stronger and less expensive than a shear bar fabricated from reinforcing steel.

The design of the shear bar allows it to fit over the top edge of an erection anchor. It is placed in the top notch and secured so that it bears tightly against the bottom of the notch. Accurate placement of the shear bar provides for spall-free edge lifts.

The P98S Shear Bar is available to fit 2, 4 and 8-ton Fleet-Lift Erection Anchors. Available in plain or hot-dipped galvanized finish.

Fleet-Lift™ System

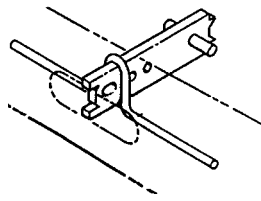

Typical Shear Bar Application

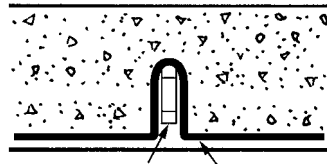

Erection Anchor Shear Bar
Top View

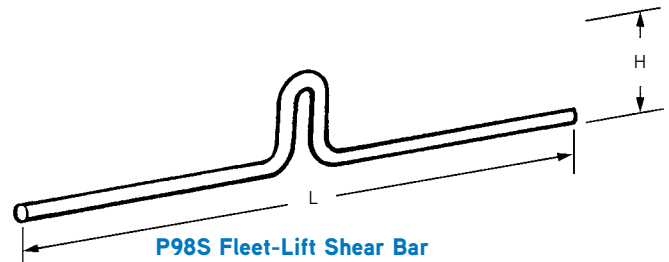

P98S Fleet-Lift Shear Bar

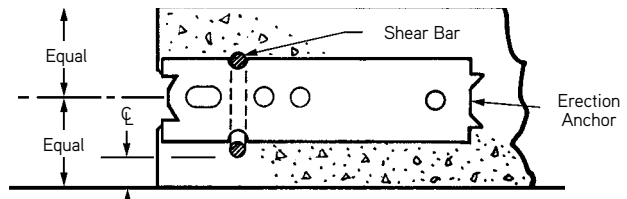

Minimum 3/4" Concrete Cover
Section View

To Order:
Specify: (1) quantity, (2) name, (3) product code, (4) corrosion resistance, if required.

Example:
200 P98S Fleet-Lift Shear Bar, FL141, hot-dipped galvanized.

Anchor Tonnage	Product Code	Shear Bar Diameter	Minimum Panel Thickness	Dimensions	
				H	L
2 to 3-ton	FL140	1/2"	4"	2-1/2"	13-7/8"
4 to 6-ton	FL141	1/2"	5-1/2"	3-5/16"	13-7/8"
8 to 12-ton	FL142	1/2"	7-1/2"	4-15/16"	13-7/8"

P98T Fleet-Lift™ Tension Bar

The Dayton Superior P98T Fleet-Lift Tension Bar is used with various Fleet-Lift Anchors to provide a simple, inexpensive method of distributing tension forces (lifting) deep into a precast member.

Anchor Tonnage	Tension Bar (Grade 60)	L=Overall Length of P98T Tension Bar		
		3,000 psi	4,000 psi	5,000 psi
1-ton or 2-ton	#3	32"	28"	26"
3-ton or 4-ton	#4	44"	38"	34"
6-ton or 8-ton	#6	66"	56"	50"
10-ton or 12-ton	#8	110"	95"	85"

L = Overall length of tension bar based on concrete compressive strength at time of lift.

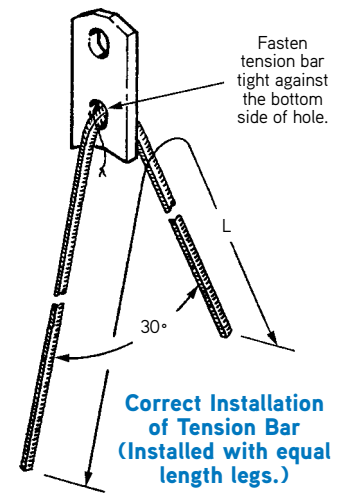

Fasten tension bar tight against the bottom side of hole.
Correct Installation of Tension Bar (Installed with equal length legs.)

P99 Fleet-Lift™ Reusable Recess Plug

The Dayton Superior P99 Fleet-Lift Reusable Recess Plug is molded from an elastomeric thermal-set urethane for multiple reuse.

Embedded in the recess plug is a stainless steel stud that securely captures a Fleet-Lift Anchor and P140 Super Lift Anchor (with adapter clip), providing a positive connection to the form during the placement of concrete. Attachment to the form is accomplished with a P100 Holding Rod and P101 Fleet-Lift Holding Plate.

P99 Recess Plugs are resistant to heat and form release agents encountered in a precast plant.

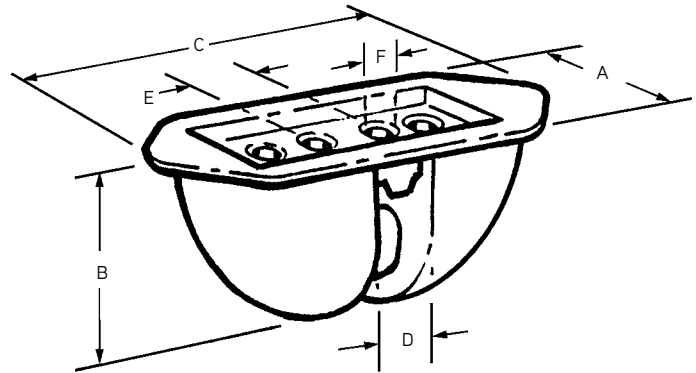
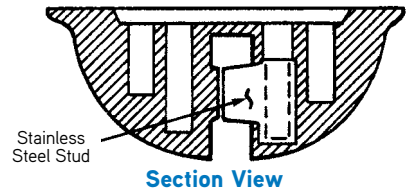

To Order:

Specify: (1) quantity, (2) name, (3) product code.

Example:

200, P99 Fleet-Lift Reusable Recess Plug, FL062.

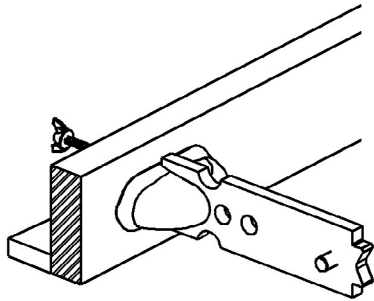

Anchor Tonnage	Product Code	A	B	C	D	E	F
1-ton	FL051	1-11/16"	1-3/4"	4-1/16"	3/16"	1-3/16"	3/8"
2-3 ton	FL200	1-11/16"	1-3/4"	4-1/16"	3/8"	1-3/16"	3/8"
4-6 ton	FL062	2-1/8"	2-5/16"	5-3/16"	5/8"	1-11/32"	3/8"
8-12 ton	FL121	3-1/8"	3-5/16"	7-13/16"	3/4"	1-31/32"	3/8"

Note: Recess Plug style FL051 is used with the 1-ton L-Anchor and 2-ton Ring Clutch combination ONLY.

P100 Fleet-Lift™ Holding Plate and P101 Fleet-Lift™ Holding Rod

P100 Fleet-Lift Holding Plate

Anchor Tonnage	Product Code	A	B	C
1-ton	FL160	5/8"	2-3/4"	10mm
2-3 ton	FL160	5/8"	2-3/4"	10mm
4-6 ton	FL144	1-1/4"	3-3/8"	10mm
8-10 ton	FL111	1-3/4"	4-7/8"	12mm

P101 Fleet-Lift Holding Rod

Anchor Tonnage	Recess Plug Material	Product Code	Standard Rod Length	Thread Diameter and Type
1, 2, 4, 6, 8 and 12-ton	Urethane	FL131	6"	3/8" Coil
1, 2, 4, 6, 8 and 12-ton	Steel	FL131C	6"	1/2" Coil

Note: Holding Rod may be special ordered in longer lengths.

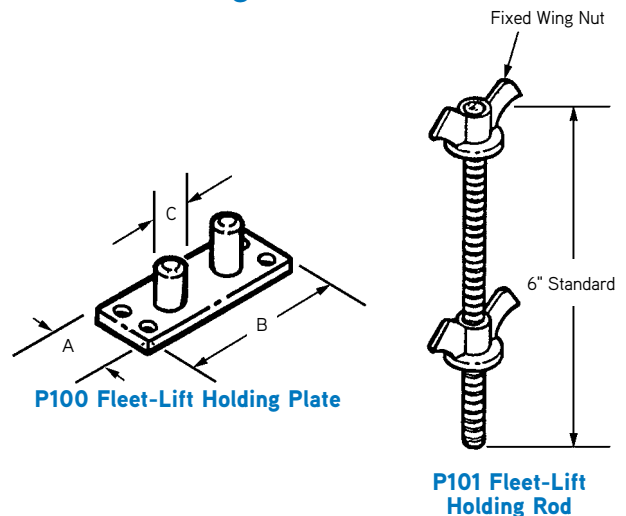

To Order:

Specify: (1) quantity, (2) name, (3) product code.

Example:

200, P100 Fleet-Lift Holding Plates, FL144.

Installation and Removal of Anchors and Reusable Recess Plugs

Installing an Anchor in the Recess Plug: A) Open the slot of the recess plug by placing a holding rod or screwdriver into an outside hole and squeeze the recess “open.” (B) Place the anchor over the steel stud and close the recess plug. The assembly is ready for

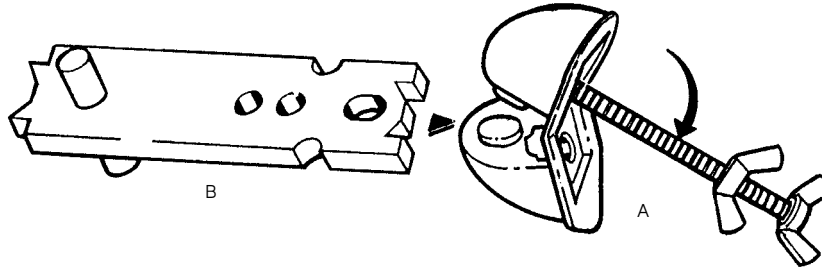

installation.

Attaching the Assembly to the Form: A) Place the assembly against the form and position over the predrilled hole. (B) Insert the 3/8" holding rod through the hole and thread into the recess plug. (C) Pull the assembly tight to the form by firmly tightening the wing nut on the holding rod.

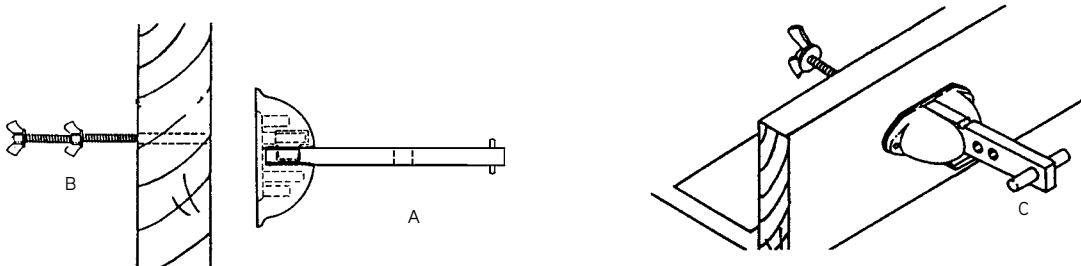

Attachment Using a Holding Plate: A) Position and attach the holding plate to the form. B) Slide the anchor assembly over the holding plate studs and firmly against the form. (C) Installation is complete.

Note: The holding plate can be used to hold the recess plug/insert assembly in the closed position to facilitate working the anchor into fresh concrete (wet setting). It is recommended that the back of the recess plug be covered with tape to protect it from being filled with concrete. Be sure to vibrate to properly consolidate the concrete around the anchor. To strip, simply remove the tape and/or cover/patch and pry the holding plate out of the recess plug with a blade screwdriver or similar tool.

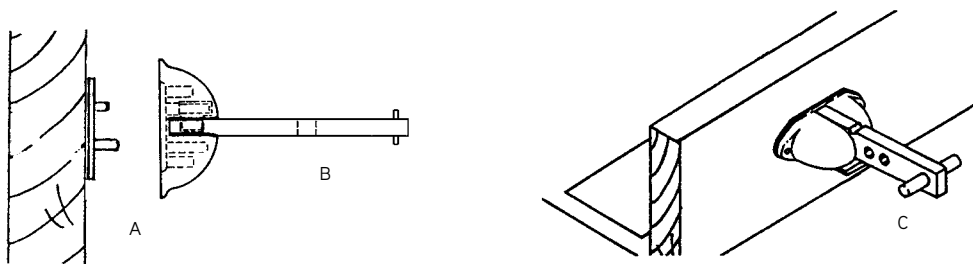

Removing the Recess Plug from the Concrete: A) After the back of the recess plug is exposed, insert a steel rod or screwdriver into the half of the recess plug opposite the threaded stud and rotate it to loosen that half of the recess plug. (B) After the first half of the recess plug has been loosened, use the holding rod in the other side in a “scissor” motion to free the recess plug.

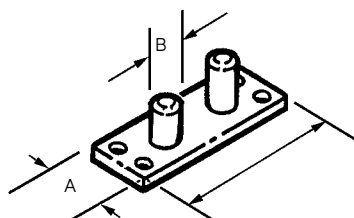

P99C Fleet-Lift™ Cast Steel Recess Plug

The Dayton Superior P99C Fleet-Lift Cast Steel Recess Plug is designed for high reuse, high curing temperatures and cold weather applications. The recess Plug uses a Steel Wedge (P102) through the anchor eye to securely hold the anchor in place. A Foam Strip (P103) fits over the head of the anchor to prevent concrete from entering the void.

The recess plug/anchor assembly is secured to the form work with the 1/2" diameter Holding Rod (P101) or simply nailed to the form. Recess plug, steel wedge and foam insert are sold separately.

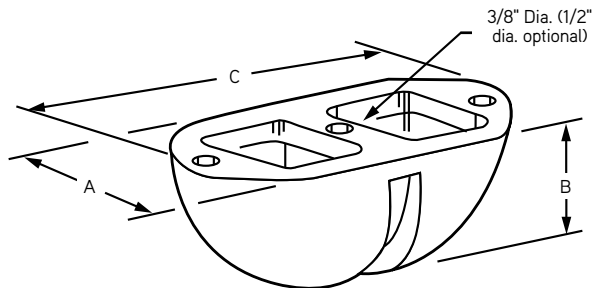

P99C Fleet-Lift Cast Steel Recess Plug

P99C Fleet-Lift Cast Steel Recess Plug

Anchor Tonnage	Product Code	A	B	C
2-3 ton	FL078	1-7/8"	1-3/4"	4"
4-6 ton	FL100	2-3/8"	2-3/8"	5-3/8"
8-12 ton	FL015	3-3/8"	3-3/8"	7-3/8"

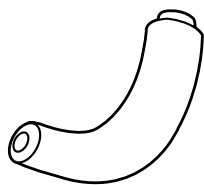

P102 Fleet-Lift Steel Wedge

P102 Steel Wedge

Anchor Tonnage	Product Code
2-3 ton	FL017
4-6 ton	FL084
8-12 ton	FL085

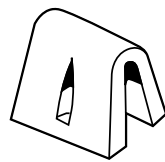

P103 Fleet-Lift Foam

P103 Foam

Anchor Tonnage	Product Code
2-3 ton	FL087
4-6 ton	FL069
8-12 ton	FL091

To Order:
Specify: (1) quantity, (2) name, (3) product code.

Example:
200, P99C Fleet-Lift Cast Steel Recess Plug, FL100.

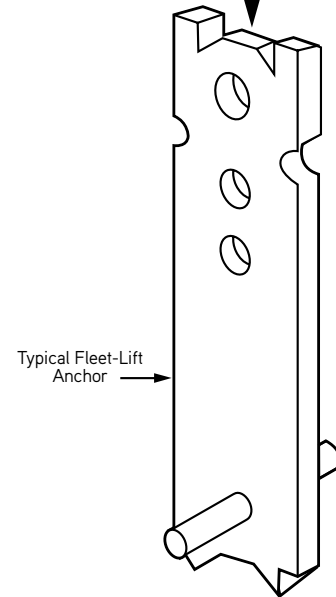
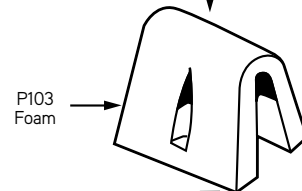
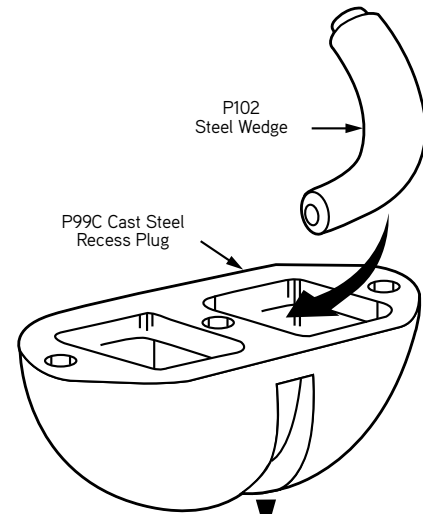

P99C Fleet-Lift Cast Steel Recess Plug Assembly Sequence

Installation and Removal of the Fleet-Lift Cast Steel Recess Plug

Installing the Cast Steel Recess Plug to an Anchor: A) Place the foam strip over the top of the anchor. (B) Place the anchor and foam into the recess slot. (C) Slide the curved steel wedge into the top of the recess plug and through the anchor's "eye" and wedge tightly.

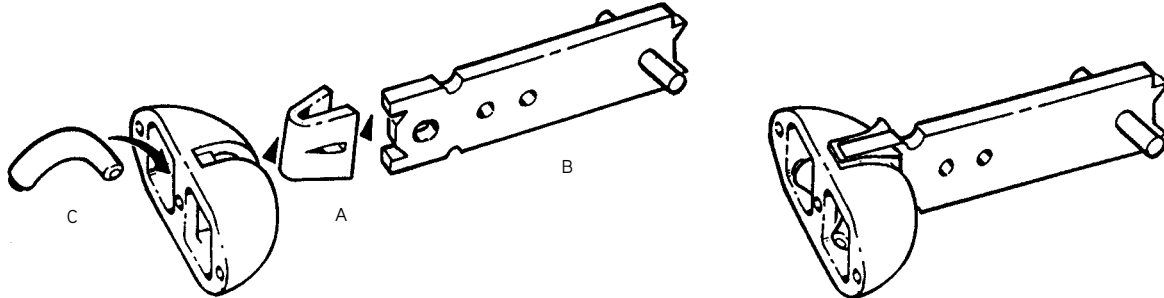

Complete Assembly

Attaching the Recess Plug/Anchor Assembly to the Form: A) Place the assembly over the predrilled hole. (B) Insert a holding rod through the hole and thread it into the recess plug. Tighten the holding rod against the anchor with the "fixed" wing nut. (C) Tighten the assembly against the form with the "free-running" wing nut.

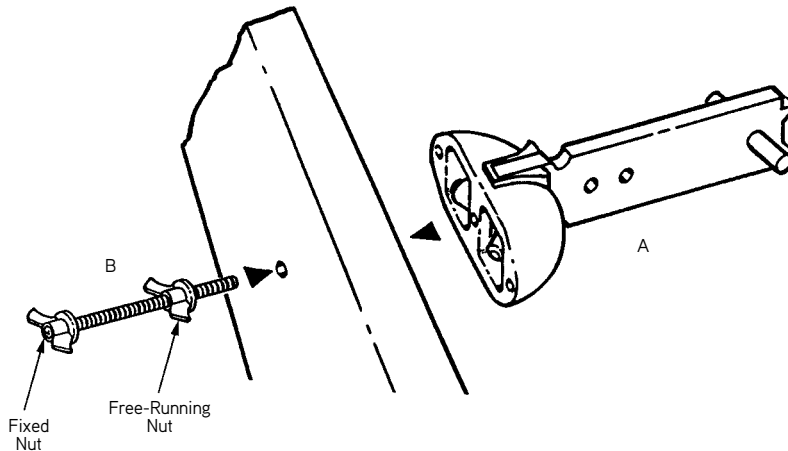

Removing the Cast Steel Recess Plug: A) Remove the holding rod from the recess plug. (B) Remove the form. (C) Remove the steel wedge by tapping on the small end with a hammer. (D) Thread the holding rod back into the recess plug and tighten until it pushes the recess out of the void.

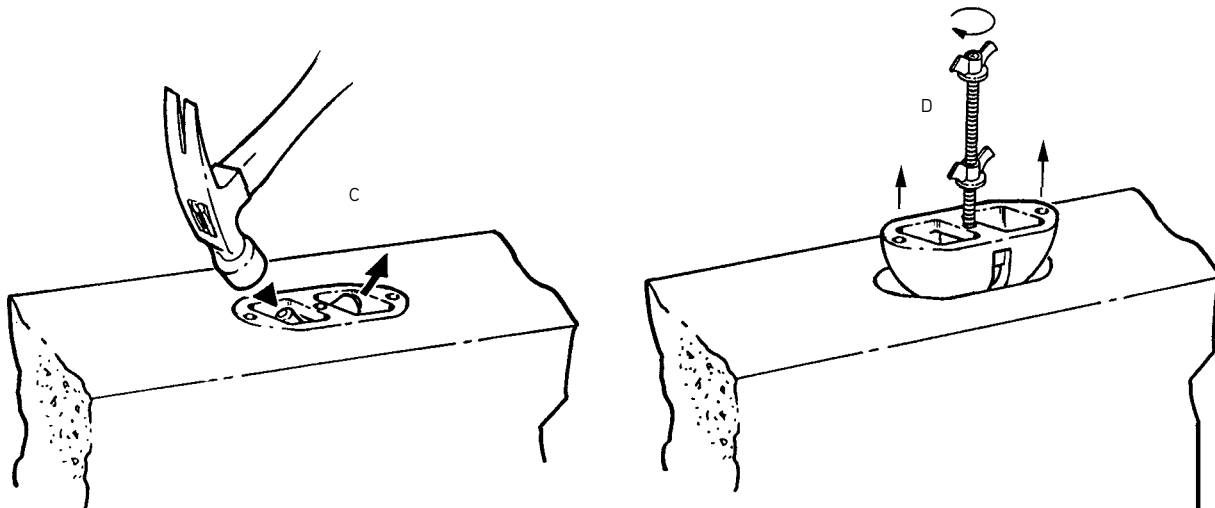

P99D Fleet-Lift™ Disposable Recess Plug (PVC)

The Dayton Superior P99D Fleet-Lift Disposable Recess Plug can be used to preset Fleet-Lift face-lift or edge-lift anchors or can be used to “wet set” P94 Anchors. The Cover/Patch fits tightly onto the recess plug to fully protect the unit. The Cover/Patch is concrete gray in color and can be used as a patch over the recess opening for temporary or permanent cover.

Recess Plug Components:

The Disposable Recess Plug can be ordered in sets consisting of a body with a preinstalled clip and a lid, or as individual pieces. This gives the system the versatility to meet your requirements without having to order parts that are not needed.

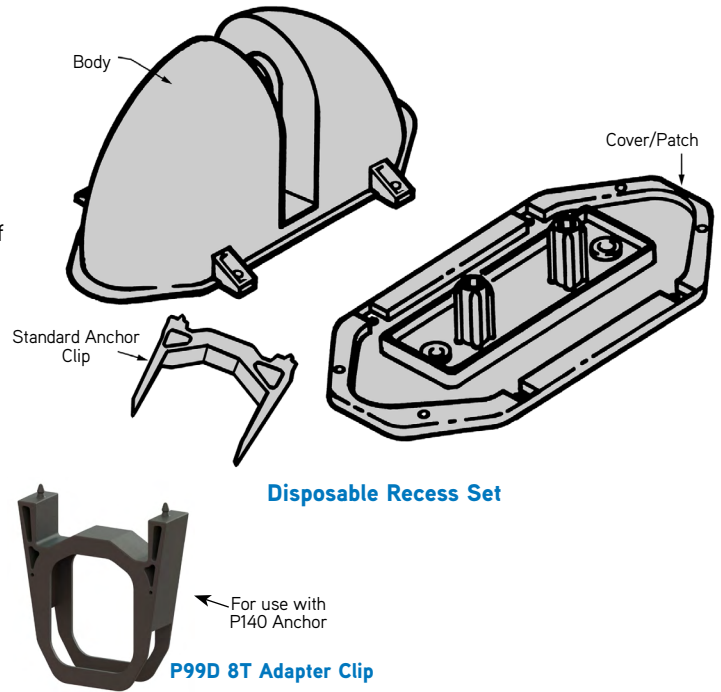

Fleet-Lift™ System

To Order:

Specify: (1) quantity, (2) name, (3) complete sets or individual part, (4) product code.

Example:

200, P99D Fleet-Lift Disposable Recess Plug Cover/Patches, FL067S.

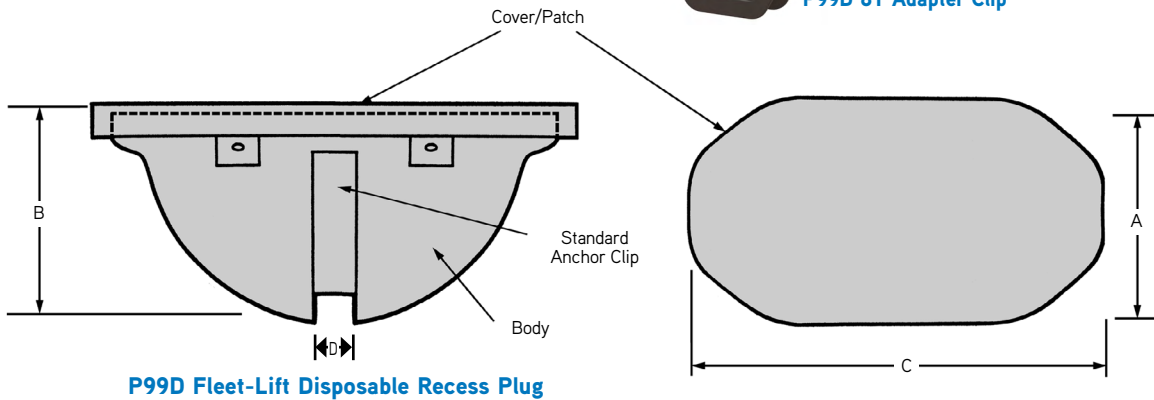

P99D Fleet-Lift Disposable Recess Plug

Anchor Tonnage	Product Description	Product Code	A	B	C	D
1, 2 and 3-ton	Body	FL066B	—	—	—	3/8"
	Lid	FL066L	2-7/16"	—	4-1/4"	—
	Filler	FL066F	—	—	—	3/8"
	Set	FL066S	2-7/16"	2"	4-1/4"	—
4 and 6-ton	Body	FL067B	—	—	—	5/8"
	Lid	FL067L	2-7/8"	—	5-1/2"	—
	Filler	FL067F	—	—	—	5/8"
	Set	FL067S	2-7/8"	2-1/2"	5-1/2"	—
8, 10 and 12-ton	Body	FL068B	—	—	—	3/4"
	Lid	FL068L	3-7/8"	—	8-5/16"	—
	Filler	FL068F	—	—	—	3/4"
	Set	FL068S	3-7/8"	3-1/2"	8-5/16"	—

Installation of P99D Disposable Recess Plug and Erection Anchors

Installing an Erection Anchor in a Disposable Recess Plug:

(A) Remove the clip from the recess plug. The clip will not be used with the erection anchor. (B) Open the body of the recess plug enough to allow the anchor to slide into the recess plug. (C) Close the recess plug around the anchor. Recess plug/anchor assembly is completed.

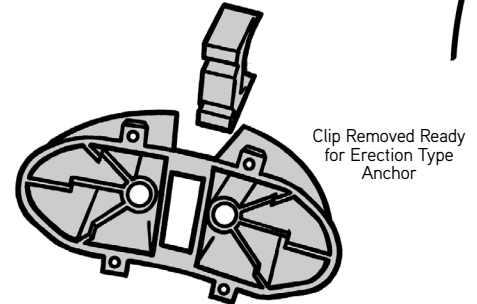
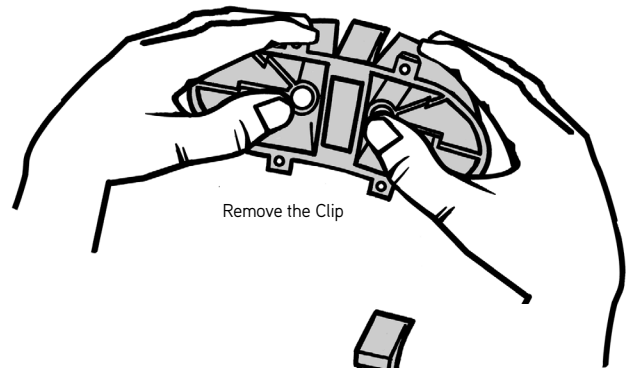

Attaching the Erection Anchor/Recess Plug to the Form:

Four methods are displayed in the sketches:

1. Edge Installation – Two Step Method – (A) Nail the cover/patch to the edge form for position. (B) Push the anchor/recess assembly onto cover/patch's studs until fully seated and nail the recess plug to the form.
2. Edge Installation – One Step Method – Place the anchor/recess plug assembly (with cover/patch attached) in the desired position and nail the assembly to the edge form.
3. Edge Installation – Double-Faced Tape – Place double-faced tape on the cover/patch and press the assembly onto the edge form in the desired position.
4. Edge Installation – With Holding Rod – (A) Drill out and remove one of the studs on the cover/patch. (B) Install the cover/patch on the recess plug body with the drilled-out hole over the threaded insert in the recess plug body. (C) Place the recess plug/anchor assembly over a predrilled hole in the edge form. (D) Firmly attach the assembly to the edge form with a 3/8" holding rod.

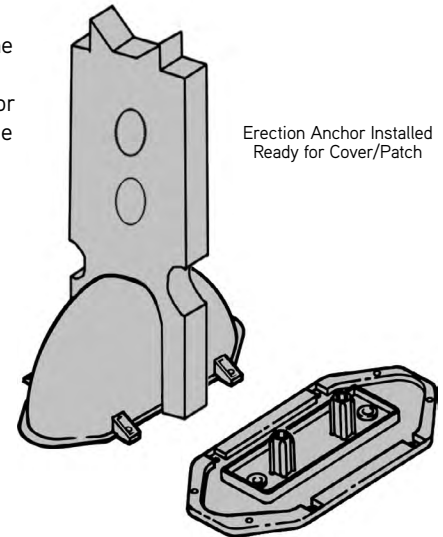

1) Edge Installation TwoStep

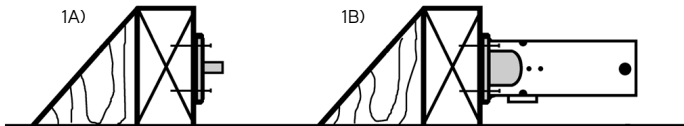

2) Edge Installation OneStep

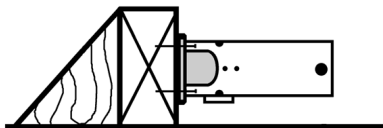

3) Edge Installation Double-Faced Tape

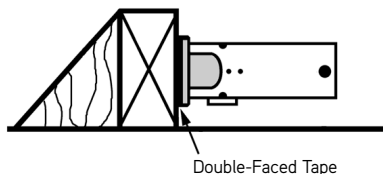

4) Edge Installation With Holding Rod

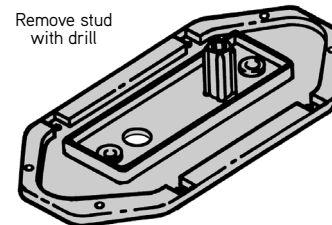
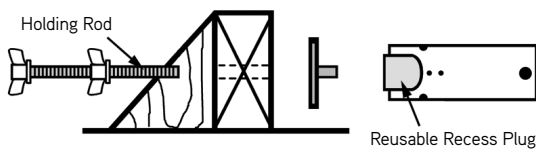

Installation of P99D Disposable Recess Plug and Standard Anchors

Installing Standard Anchors in the Disposable Recess Plug:

To install standard, non-erection head anchors, open the Dayton Superior P99D Disposable Recess Plug just enough to allow the anchor to be inserted fully into the body of the recess plug. Do not excessively open the body to avoid damaging the recess plug. Note that the anchor clip fits snugly against the anchor to seal out any concrete leakage. Snapping the cover/patch onto the recess plug completes the installation.

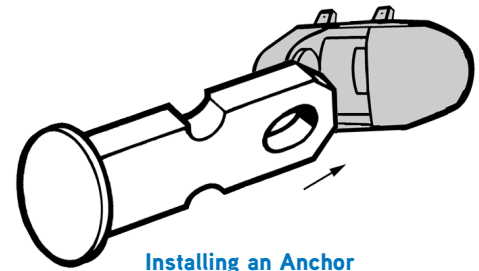

Installing an Anchor

Setting Standard Anchors with the Disposable Recess Plug:

The recess plug/anchor assembly can be set in position in a variety of methods: (1) by nailing it to a support beam and suspending it above the surface of the concrete, (2) nailed or double-faced taped to the form face or (3) wet set. Wet setting is accomplished by nailing or taping the assembly to a small template board and then working the assembly down into the freshly poured concrete. Light vibration is usually needed to ensure good bond around the anchor. A properly placed anchor will have the cover/patch slightly below the surface of the concrete. This will facilitate screeding operations and will aid in locating the recess after curing.

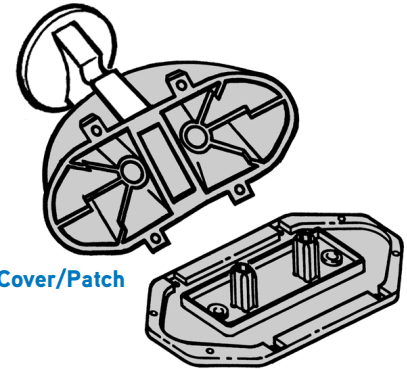
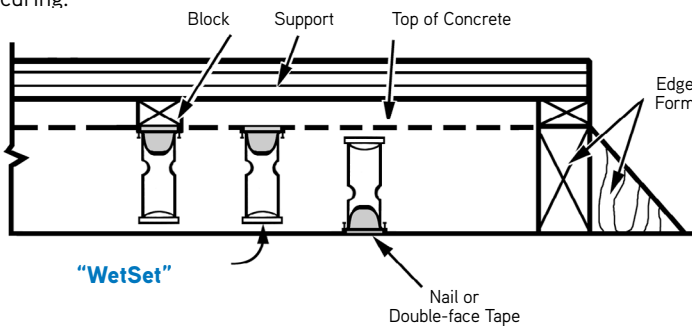

Install Cover/Patch

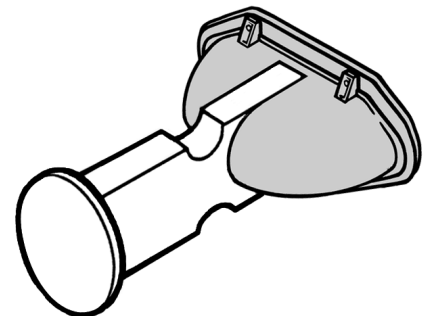

S-Anchor Installed

Disposable Recess Plug Removal:

(A) To remove the cover/patch – Place a blade screwdriver in the center of cover/patch’s side and carefully dislodge and remove the cover/patch. (B) To remove the recess plug’s body – Insert a screwdriver or similar tool into each round hole in the recess plug and rotate the tool to remove the body. The anchor clip may remain in the recess and require a separate removal.

Remove recess body by inserting screwdriver into **each** round hole and rotate to release. Remove body.

Note: Body clip may remain in recess and require separate removal.



When used with P140



P99D Temporary Cover/Patch Installation

The Dayton Superior P99-D Cover/Patch can be used as a temporary cover to keep sand, rain, snow, debris, etc., out of the recess. Under normal precast plant yard conditions, it will stay in place without adhesive.

When planning to use the cover/patch as a temporary cover, be careful when removing the cover to avoid damage. Simply replace the cover/patch into the formed recess, flush with the surface of the concrete. A silicone adhesive may be used on the inner rim of the recess to prevent water from entering the recess.

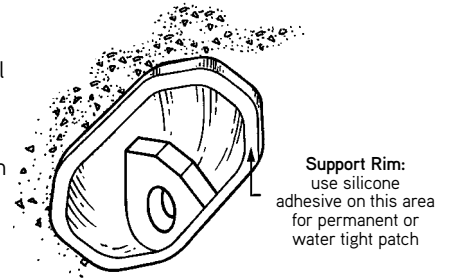

Permanent Cover/Patch Installation

When used as a permanent patch, the cover/patch eliminates the need to grout and will protect the anchor from the environment. The light gray color of the unit will blend with most normal concrete, or it can be painted to closely match other color applications.

When anticipating the use of the cover/patch as a permanent application, be careful during removal to protect the integrity of the concrete around the perimeter of the recess. An application of a silicone or other type adhesive to the inner rim of the recess will seal out the elements or other contaminants. If the recess plug/anchor assembly was installed flush with the concrete surface, the cover/patch will be flush in its permanent position. Future access to the anchor is easily accomplished by removing the cover as described earlier.

Additional cover/patches may be purchased separately, if required.

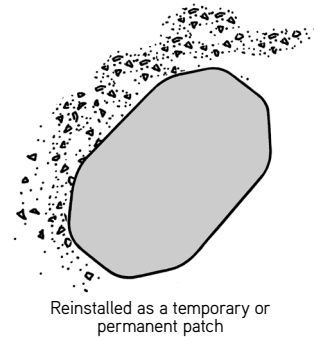

Protective Cap for Reusable Recess Plugs

The cover/patch can be used as a protective cap for the reusable recess plug. This will protect the recess plug and will eliminate the use of duct tape to cover the back of the recess plug. After installing the anchor in the recess plug, snap the cover/patch onto the recess plug. The cover/patch can be ordered separately for this purpose and can be used and reused many times in this type of installation.

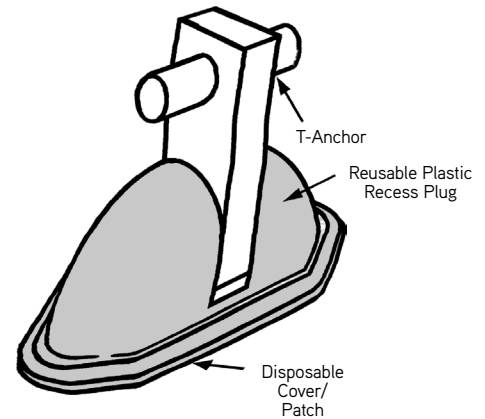

Fleet-Lift™ System

P99P Fleet Patch

The Dayton Superior P99P Fleet Patch is a durable plastic patch designed to quickly cover 2-6-ton Fleet-Lift setting plug recesses. The P99P patch is fabricated from an additive stabilized polypropylene to maintain the patch's slightly convex shape. The convex shape helps to keep a constant gripping pressure after installation. The patch is supplied in a concrete gray color with a matte finish that allows subsequent painting, if desired.

Fleet Patch Advantages:

- Special shape-holding composition
- Fast, one-piece "push-on" installation
- Paintable concrete gray matte finish
- Full eight (8) inch diameter
- Weather and chemical resistant
- Self adjusting grippers

The P99P Fleet Patch is a high quality, one piece plastic patch that is easy to install and maintain. It will provide a quick and economical solution to covering Fleet-Lift anchor recesses.

Typical P99P Fleet Patch Installation:

- 1) Start the patch grippers on the top edge of the anchor
- 2) Push the patch onto the anchor and flush with the concrete

Note: The P99P Fleet Patch will not prevent corrosion or rusting of an embedded anchor that is subject to wet conditions. Spraying the anchor with a corrosion resistant compound and applying a bead of silicone around the underside of the patch will help prevent moisture penetration.

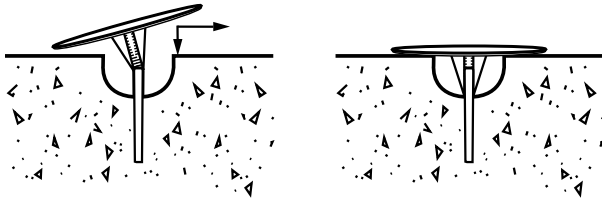

Fleet-Lift™ System

P99P Fleet Patch

Fleet Patch

Sales Category	Product Code	Weight for 100
P99P	FL612	24 lbs.

To Order:

Specify: (1) quantity, (2) name, (3) product code.

Example:

200, P99P Fleet Patch, FL612.

P100M Fleet-Lift™ Magnetic Plate

The Dayton Superior P100M Fleet-Lift Magnetic Plate eliminates the need for drilling setting-bolt holes in steel forms. Installed into a rubber base is a set of strong, reliable magnets. These magnets, along with an attachment stud and setting screw, work together to hold a Fleet-Lift anchor tightly in position during the placement of concrete.

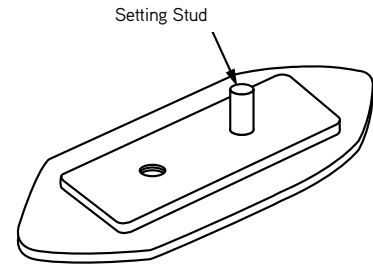

P100M Fleet-Lift Magnetic Plate

The P100M Magnetic Plate is available in three sizes to fit the three P99 Fleet-Lift Recess Plugs.

Fleet-Lift™ System

P100MS Setting Screw

Provided with 3/8" coil threads and used to attach the magnetic setting plate to the P99 Recess Plug, this unit has either a slot or hex in the head.



P100MS Setting Screw

Use the 1-1/2" long setting screw with the 1 to 4-ton system and the 2-3/8" long setting screw with the 8-ton system.

P100M Fleet-Lift™ Magnetic Plate Installation

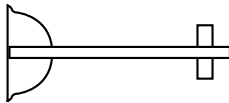

1. Attach Fleet-Lift Anchor to recess plug.

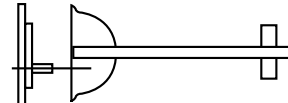

2. Push recess plug onto setting stud of the magnet using the non-threaded middle hole.

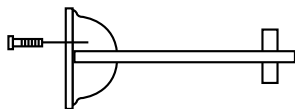

3. Place the P100MS Setting Screw through the hole in setting plate, securing setting plate tightly to recess

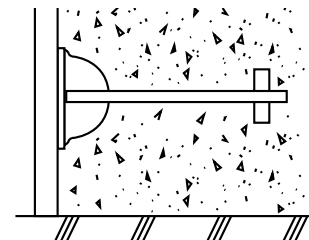

4. Carefully set complete anchor assembly into proper position in the form.

P104F Fleet-Lift™ One Piece Magnetic Recess

The Dayton Superior P104F One Piece Magnetic Recess allows installation of the Fleet anchors in a metal face form using a one piece rubber recess with magnets imbedded in the top of the recess. Available in 2T, 4T and 8T products.

