

Fleet-Lift[™] System Overview

The Dayton Superior Fleet-Lift System comprises two main parts, the Fleet-Lift Anchor and the Fleet-Lift Ring Clutch. The design of the system allows loads to be applied from any direction.

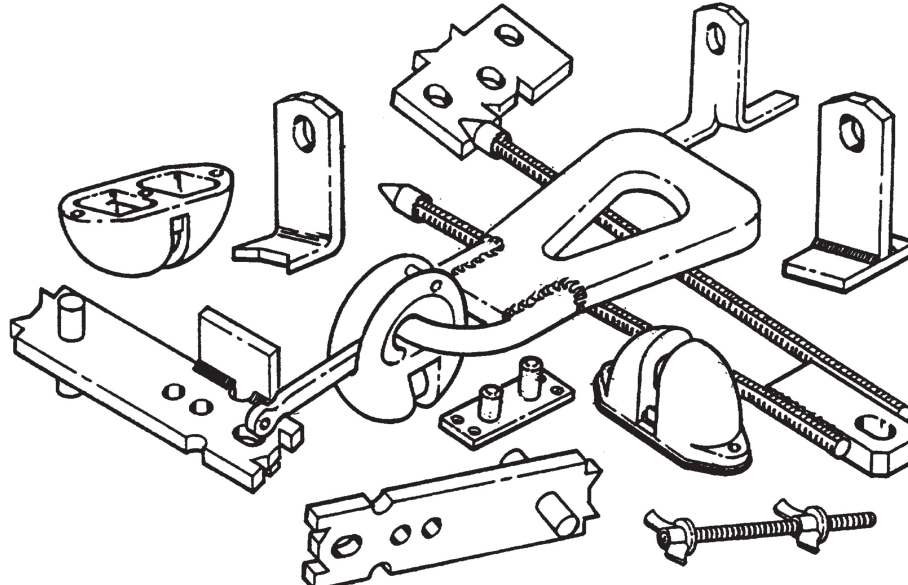

Fleet-Lift System Components

The selection of the proper capacity Fleet-Lift System is based on several factors, such as:

- Size of precast element
- Rigging configuration
- Compressive strength of concrete at initial lift
- Embedment depth of anchor
- Edge distance
- Anchor spacing
- Direction of applied load
- Use of tension bars, shear bars or shear plates.

Each Fleet-Lift anchor is stamped with its MAXIMUM safe working load and the letters DSC, which identifies it as a Dayton Superior Corporation product. The hole near the top of the anchor head is designed to receive the appropriate size ring clutch.

Both the anchor and ring clutch are rated with a safe working load. The safe working load of the anchor is based on a factor of safety of 4 to 1 (ultimate to safe). Each ring clutch has a Load Range embossed on it, which shows the anchors it can be used with. A factor of safety of 5 to 1 is applied to the highest load in the range for each size of ring clutch.

To use, simply push the ring clutch onto the head of the anchor that is located in a recess created by a Fleet-Lift recess plug. Once the ring clutch is pushed onto the head of the anchor, the ring clutch's curved bolt is pushed through the hole in the anchor. This locks the ring clutch and anchor into a single unit ready to lift the precast concrete element.

To disengage the anchor and ring clutch, simply pull the curved bolt free of the anchor. This allows the ring clutch to be easily removed from the head of the anchor.

Dayton Superior recommends a minimum 3/4" cover between the bottom of an anchor and the concrete surface. This minimum recommended concrete cover is to prevent anchor corrosion.