

Proper Method for Installing Load Key Joint

Step 1:

When a thickened contraction joint is specified, and the shape and/or dimensions are not given, experience and research have shown that the slab thickness should be $\frac{2}{3}$ of the joint thickness, with the increase in thickness being obtained by a straight slope in the outer two feet of the slab, as shown in the sketch. Key dimensions should be as shown, with the key centered vertically in the joint.

Note: Joint thickness should be determined by the designer, so that repeated stress does not exceed 50% of the ultimate strength.

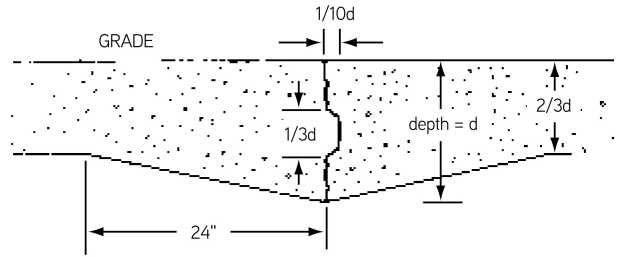

Step 2:

Stretch a line over the entire length. Drive stakes are placed on approximately 20 foot centers. Set stakes $\frac{1}{8}$ " below finished floor elevation. Secure the line to the top of the stakes (as shown in the inset). Drive additional stakes to the bottom of the line at the end location of each Load Key section.



Step 3:

Stake Driving can be facilitated with the use of the G36 Stake Driving Tool (available on special order). The G36 tool prevents the top of the stake from being flattened, as well as acting as a guide. A 2x4 placed adjacent to the stake will help align the stake vertically.



Step 4:

Install Load Key Joint on the stakes as shown. Butt joints are aligned at a stake as shown in the inset.

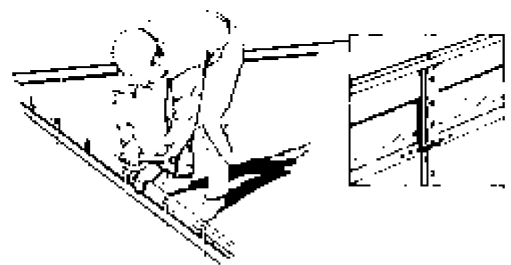

Step 5:

Drive intermediate stakes through holes provided in the formed keyway.

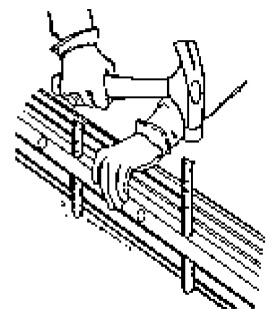

Step 6:

When joints meet at right angles, Load Key can be trimmed to fit as shown. Note the stakes are placed in close proximity to the joint.

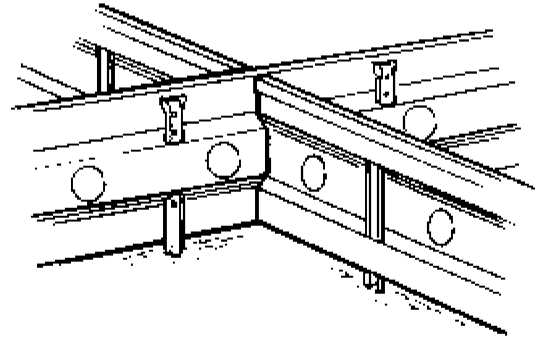

Step 7:

1-1/8" knockouts are supplied, as shown, on 6" centers when doweling is specified. When Load Key Joint is used as a bulkhead for a construction joint, the knockout would be bent back into the pour at a 45° angle, as shown. The knockout holes may be used to pass conduit up to 1" O.D. Additional bracing (as shown) will be required for bulkhead pours. Load Key Joint should remain in place when bulkhead bracing is removed.

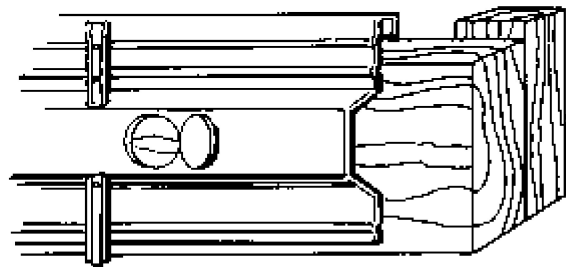

Step 8:

Load Key Joint will only support a manual screed, to strike-off concrete, when concrete is placed simultaneously on both sides of the Load Key before screeding. Failure to place concrete equally on both sides of the joint may cause misalignment or bending of the Load Key.

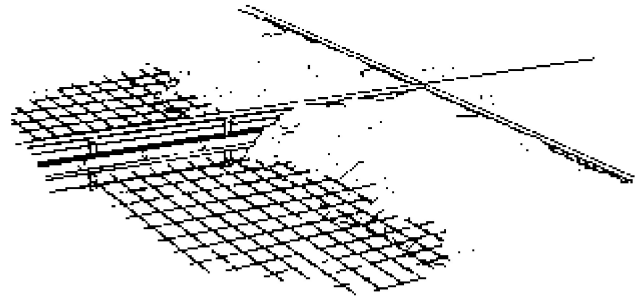

Step 9:

A common and economical method is to pour concrete in strip fashion as shown. When a strip is poured and finished, there are no added steps such as, cutting or stripping. Use temporary bulkhead for support behind each key joint.

