

P93 Fleet-Lift™ L-Anchor

The Dayton Superior P93 Fleet-Lift L-Anchor is a very efficient anchor. This anchor is used for both stripping and erection carrying tension and/or shear loads (except for edge shear in thin panels). The L-Anchor produces exceptionally high pullout strength for its size, due to its foot design.

The L-Anchor can be placed on the face, back, or thicker panel edge allowing for back-stripping and their rotation from horizontal to vertical.

The P93 anchor is available in plain or hot-dipped galvanized finish. This anchor requires the use of the 2/5-ton range ring clutch and the 2/3-ton load range recess plug.

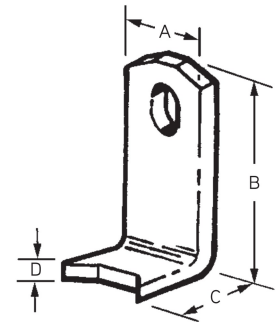

P93 Fleet-Lift L-Anchor

To Order:

Specify: (1) quantity, (2) name, (3) product code, (4) finish.

Example:

200 P93 Fleet-Lift L-Anchor, FL050, hot-dipped finish.

P93 Fleet-Lift L-Anchor (ton x length)	Product Code	Precast Concrete Panel Thickness	Minimum Edge or Corner Distance	Shear Safe Working Load for Shear	Tension Safe Working Load Anchor Only	A	B	C	D
1-ton x 4" long	FL050	5" Min.	12"	2,000 lbs.	2,000 lbs.	1-1/4"	4"	1-7/16"	3/16"

Notes:

Safe Working Load provides an approximate factor of safety of 4 to 1 in 3,500 psi normal weight concrete.

Anchor is not designed for use in thin edge shear conditions.

Anchor must use FL051 (P99) Reusable Recess Plug

P94 Fleet-Lift T-Anchor

The P94 Fleet-Lift T-Anchor is a versatile anchor available in many sizes and lengths. Its high pullout strength allows it to be used for back-stripping and erection. T-Anchors can be placed on the face, back or edge of panels allowing for back-stripping and rotation from horizontal to vertical.

P94 anchors are available in plain or hot-dipped galvanized finish.

To Order:

Specify: (1) quantity, (2) name, (3) product code, (4) finish.

Example:

200, P94 Fleet-Lift T-Anchors, FL850, hot-dipped galvanized.

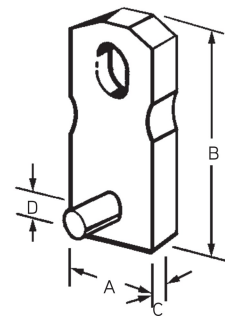

P94 Fleet-Lift T-Anchor 4-ton

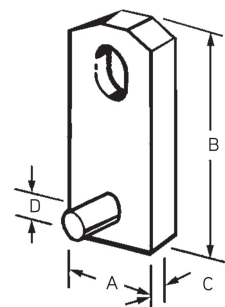

P94 Fleet-Lift T-Anchor 2, 6 and 8-ton

P94 Fleet-Lift L-Anchor (ton x length)	Product Code	Min. Precast Concrete Panel Thickness	Minimum Edge or Corner Distance	Shear Safe Working Load	Tension Safe Working Load	A	B	C	D
2-ton x 4" long	FL110	4-3/4"	8"	4,000 lbs.	4,000 lbs.	1-1/4"	4"	3/8"	1/2"
2-ton x 5-1/2" long	FL059	5-7/8"	11"	4,000 lbs.	4,000 lbs.	1-1/4"	5-1/2"	3/8"	1/2"
4-ton x 4-1/4" long	FL848	4-5/8"	8-1/2"	5,500 lbs.	5,500 lbs.	1-1/2"	4-1/4"	5/8"	1/2"
4-ton x 4-3/4" long	FL849	5-1/8"	9-1/2"	7,100 lbs.	7,100 lbs.	1-1/2"	4-3/4"	5/8"	1/2"
4-ton x 5-1/4" long	FL850	5-5/8"	10-1/2"	8,000 lbs.	8,000 lbs.	1-1/2"	5-1/4"	5/8"	1/2"
4-ton x 5-3/4" long	FL851	6-1/8"	11-1/2"	8,000 lbs.	8,000 lbs.	1-1/2"	5-3/4"	5/8"	1/2"
4-ton x 6-1/4" long	FL852	6-5/8"	12-1/2"	8,000 lbs.	8,000 lbs.	1-1/2"	6-1/4"	5/8"	1/2"
4-ton x 6-3/4" long	FL853	7-1/8"	13-1/2"	8,000 lbs.	8,000 lbs.	1-1/2"	6-3/4"	5/8"	1/2"
4-ton x 7-1/4" long	FL854	7-5/8"	14-1/2"	8,000 lbs.	8,000 lbs.	1-1/2"	7-1/4"	5/8"	1/2"
4-ton x 7-3/4" long	FL855	8-1/8"	15-1/2"	8,000 lbs.	8,000 lbs.	1-1/2"	7-3/4"	5/8"	1/2"
6-ton x 11-1/8" long	FL319*	11-1/2"	23"	12,000 lbs.	12,000 lbs.	2-1/2"	11-1/8"	5/8"	3/4"
8-ton x 6-1/8" long	FL055	6-1/8"	12-1/4"	7,950 lbs.	7,950 lbs.	2-1/2"	6-1/8"	3/4"	3/4"
8-ton x 11-1/8" long	FL119	11-3/4"	23"	16,000 lbs.	16,000 lbs.	2-1/2"	11-1/8"	3/4"	3/4"

Safe Working Load provides a factor of safety of approximately 4 to 1 in 3,500 psi normal weight concrete.

Side notches are provided on 4-ton T-Anchors only.

No side notches are provided on 2, 6 and 8-ton T-Anchors.

Use 8-10T P99 Recess and P91 Ring Clutch with FL319*.

P94H Fleet-Lift™ H-Anchor 2-Ton

The Dayton Superior Fleet-Lift H-Anchor (P94H) is unique in design simplicity. It offers exceptional strength for lifting and handling precast elements, yet can be used in panels as thin as 3". The P94H anchor can be easily preset in the form or "wet set" after the concrete has been poured. The H-Anchor is the strongest and most economical precast lifting anchor available for back-stripping. H-Anchors are available in plain and hot-dipped galvanized finish.

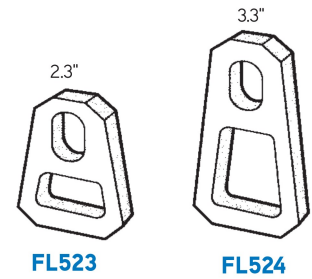

Fleet-Lift™ System

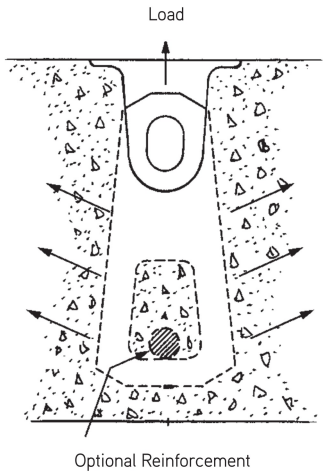

To Order:
Specify: (1) quantity, (2) name, (3) product code, (4) corrosion resistance, if required.

Example:
200, P94H Fleet-Lift H-Anchor, FL525, hot-dipped galvanized.

P94H Safe Working Load

Product Code	Load Range	Tension Load 4:1 SF	Tension with Reinforcement** 4:1 SF	Shear Load 4:1 SF	Minimum Edge Distance	Ultimate Mechanical Strength
FL523	2-ton	2,205 lbs.	2,900 lbs.	2,205 lbs.	8"	16,000 lbs.
FL524	2-ton	3,255 lbs.	4,000 lbs.	3,255 lbs.	10"	16,000 lbs.

Safe Working Load provides a factor of safety of approximately 4 to 1. Table is based on a minimum concrete compressive strength of 3,500 psi.

* When panel edge installation is required, use the H-Anchor or Two-Hole Anchor with a tension bar. Contact Dayton

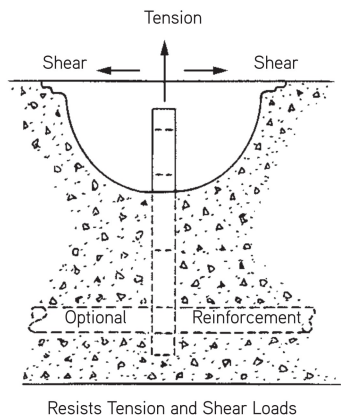

Superior Technical Assistance for minimum tension reinforcement.

** #4 x 12" long placed directly at centerline and against bottom of hole. See sketches at left.

P94H Dimensions 2/3 Ton Ring Clutch System (2-Ton Anchor)

Product Code	A	B	C	D	Minimum Slab Thickness	Weight Each
FL523	1.25"	2.30"	.35"	.56"	3"	.28 lbs.
FL524	1.25"	3.30"	.38"	1.44"	4"	.36 lbs.

P94H H-Anchors are available in plain and hot-dipped galvanized.

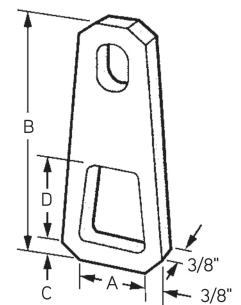

P94S Fleet-Lift™ S-Anchor

The Dayton Superior P94S Fleet-Lift S-Anchor is a high-strength, hot forged anchor that can be “wet set” or used with the optional T41 Plastic base in face-lift applications. When the P94S anchor is used with the Fleet-Lift high capacity ring clutches, safe working loads up to 20,000 pounds can be realized. See the table below for appropriate anchor lengths and concrete compressive strengths.

To Order:

Specify: (1) quantity, (2) name, (3) product code, (4) finish.

Example:

400, P94S Fleet-Lift S-Anchors, FL505 with hot-dipped galvanized finish.

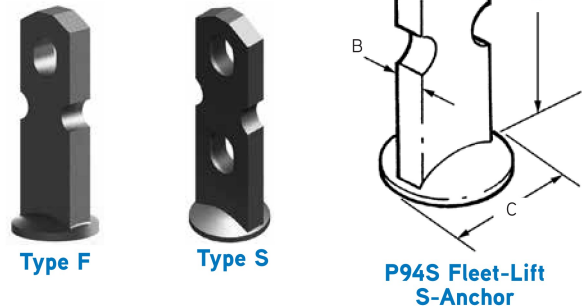

P94S Fleet Lift S-Anchor

Anchor Tonnage	Length (L)	Width (A)	Thickness (B)	Foot Diameter (C)	SWL Tension / Shear
2.5	3-1/2"	1-5/16"	3/8"	1-1/2"	3,900 lbs.
	4"				4,400 lbs.
6	3-7/8"	1-1/2"	5/8"	1-7/8"	5,000 lbs.
	4-1/8"				5,370 lbs.
	4-7/8"				6,560 lbs.
	5-1/8"				6,970 lbs.
	5-7/8"				8,250 lbs.
	6-7/8"				10,070 lbs.
10	7"	2-5/8"	3/4"	2-7/8"	12,500 lbs.

Safe working load is based on an approximate factor of safety of 4 to 1 in 3,500 psi normal weight concrete
Minimum edge distance is 1.5 x the anchor length.

P95F Fleet-Lift™ Flat Foot Anchor

The Dayton Superior P95F Fleet-Lift Flat Foot Anchor is a versatile anchor that can be used to back-strip and transport thin panels. This anchor may also be used to erect the panels.

The anchor’s safe working load may be increased by adding four 18" lengths of #4 rebar as shown in the illustration.

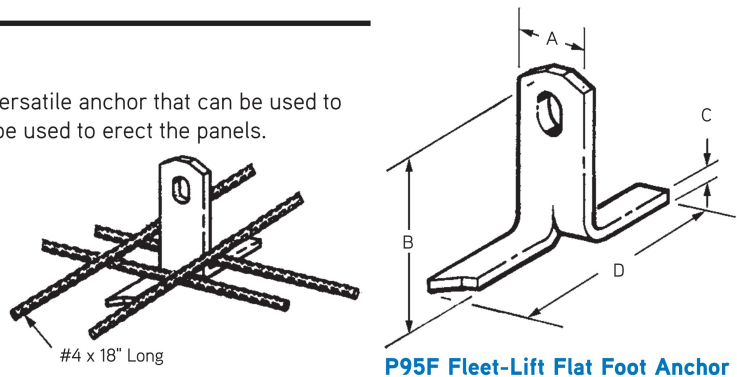

To Order:

Specify: (1) quantity, (2) name, (3) product code.

Example:

200, P94F Fleet-Lift Flat Foot Anchor, FL058.

P95F Fleet-Lift Flat Foot Anchor (ton x length)	Product Code	Precast Concrete Min. Panel Thickness	Minimum Edge or Corner Distance	Shear Safe Working Load	Tension Safe Working Load	Shear Safe Working Load Reinforced	Tension Safe Working Load Reinforced	A	B	C	D
2-ton x 2-3/4" long	FL058	3-7/8"	5-1/2"	1,325 lbs.	1,325 lbs.	4,000 lbs.	4,000 lbs.	1-1/4"	2-3/4"	3/8"	4"
2-ton x 3-3/8" long	FL400	4-1/2"	6-3/4"	1,875 lbs.	1,875 lbs.	4,000 lbs.	4,000 lbs.	1-1/4"	3-3/8"	3/8"	4"
3-ton x 3-3/4" long	FL157	4-7/8"	7-1/2"	2,350 lbs.	2,350 lbs.	6,000 lbs.	6,000 lbs.	1-1/2"	3-3/4"	1/2"	4"

Safe working load is based on an approximate factor of safety of 4 to 1 in 3,500 psi normal weight concrete.
NOTE: A minimum 3/4" concrete cover below the anchor is required to achieve posted working loads.