

Proper Installation of T3 and T11 End Pickup Inserts

When using end pickup inserts, a 1/2" thick wood washer, length of plastic pipe or cut washers must be used against the ends of the loops. This is necessary so that when the lifting plate is tightened down, it will bear against the concrete and not against the loop ends. This procedure is necessary to develop the safe working load of the end pickup inserts. End pickup inserts must be located in the center of the panel structural thickness to obtain their safe working load.

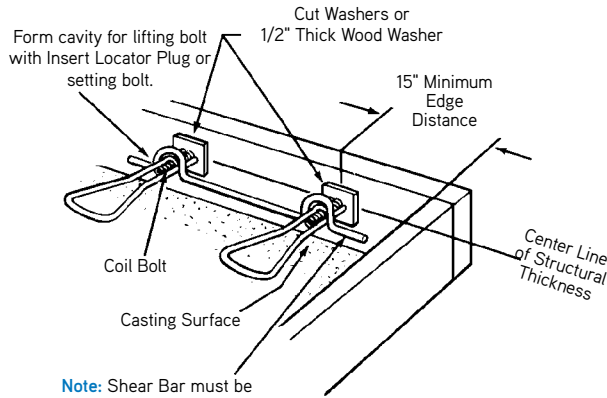

Note: Shear Bar must be on top of coils for T3 or T3A inserts.

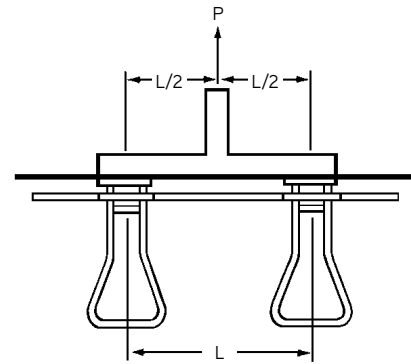

Note: To achieve Safe Working Load, Lifting Plate must be centered on T3 or T11 Insert

How To Determine Bolt Length

Always check to make certain that you have the proper clearance under the coil to prevent the lifting bolt from bottoming out against the concrete. You must be able to tighten the bolt securely to prevent the lifting hardware from slipping and applying unexpected loads to the insert.

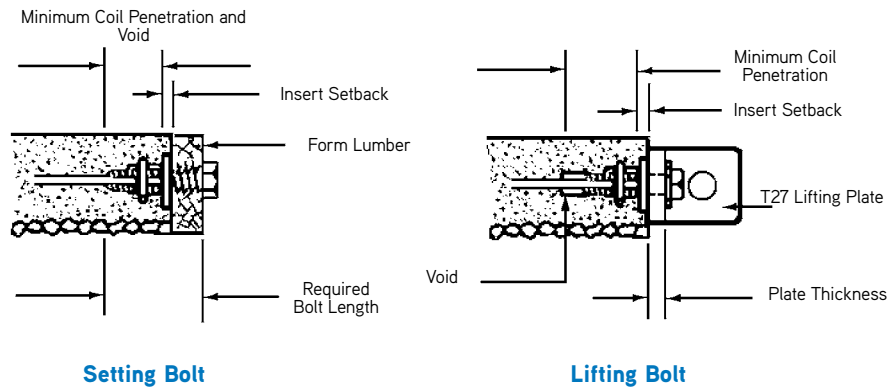

Note: Face insert lifting bolt lengths are calculated in a similar manner to that shown above.

Safety Notes

- Coils must be perpendicular to the slab edge to achieve safe working loads shown.
- Inserts must be set back 1/2" from the concrete surface in order to achieve safe working loads shown.
- Coil bolt penetration must agree with minimums shown above.

Setting Bolt for Edge Inserts		Lifting Bolt for Edge Inserts	
Form Lumber	1-1/2"	T27 Plate Thickness	1"
Insert Setback	1/2"	Insert Setback	1/2"
Minimum Coil Penetration	2-1/2"	Minimum Coil Penetration	2-1/2"
Minimum Void	1/2"	Total Bolt Length	4"
Total Bolt Length	5"		