

GENERAL INFORMATION

THREADED STUDS, ROD HANGERS & ASSEMBLIES

PRODUCT DESCRIPTION

Threaded studs are available in 1/4"-20 and 3/8"-16 thread diameters with a variety of external thread and shank lengths for use in concrete, concrete over steel deck, concrete masonry walls and steel. They are used for applications where it may be desirable to remove the fixture or where shiming may be required or for suspending small diameter pipe (e.g. water lines, sprinkler systems). Knurled shank designs are available to increase performance in steel base materials. A plastic flute is mounted on the pin shank to retain the drive pin in the barrel of the tool providing guidance during the driving operation.

Rod hangers and post nut hanger clips are available for suspending mechanical and electrical components from concrete and steel. They have an internally threaded clip or post nut designed to accept either 1/4"-20 or 3/8"-16 threaded rod.

For the electrical trade, BX and EMT (electrical metallic tubing) conduit clips are provided in various sizes for attaching conduit to base materials where easy removal is not a requirement.

Rebar basket clips are typically used in highway construction and paving applications to hold the support baskets for the reinforcing bars in place while the concrete is being poured.

GENERAL APPLICATIONS AND USES

- Threaded stud attachments for concrete, concrete over steel deck, concrete masonry and steel
- Attaching threaded rod hangers to concrete or steel
- BX cable and EMT (electrical metallic tubing) attachments
- Rebar/dowel basket anchorage

APPROVALS AND LISTINGS

- International Code Council, Evaluation Service (ICC-ES), ESR-2024
- Code compliant with the International Building Code/International Residential Code: 2018 IBC/IRC, 2015 IBC/IRC, 2012 IBC/IRC, and 2009 IBC/IRC
- Tested in accordance with ASTM E1190 and ICC-ES AC70 for use in concrete, concrete masonry and steel

GUIDE SPECIFICATION

- CSI Divisions: 03 15 00 - Concrete Accessories, 05 05 23 - Metal Fastenings, 06 05 23 - Wood, Plastic and Composite Fastenings, 09 22 16.23 - Fasteners. Power-driven fasteners shall be threaded studs, rod hangers & assemblies as supplied by DEWALT, Towson, MD. Fasteners shall be installed in accordance with published instructions and the Authority Having Jurisdiction.

SELECTION GUIDE

Pin / Fastener Assembly		Dimensions		Base Material			DEWALT Tools						Approvals & Listings			
		Shank Diameter	Shank Length	Concrete	Lightweight Concrete	Concrete over Steel Deck	Concrete Masonry (CMU)	Steel	P1000 / T1000	P2201	P35S	P3500 / PAS500		P3600	Sniper	DFD270
Threaded Studs	1/4"-20 Threaded Stud (UNC)	0.145"	1/2" to 1-1/4"	●	●	●	●	○	○	●	●	●	●	●	●	ICC-ES ESR-2024
	3/8"-16 Threaded Stud (UNC)	0.205"	3/4" to 1-1/4"	●	●	●	○	●					●			ICC-ES ESR-2024
Hangers	Post Nut Hangers (0.300" Head Pins)	0.145"	1-1/4"	●	●	●	●	○	○	●	●	●	●	●	●	ICC-ES ESR-2024
	Rod Hangers (0.300" Head Pins)	0.145"	1-1/4"	●	●	●	○	●	○	○	●	●	●	●	●	
Assemblies	BX & EMT Conduit Clips (0.300" & 8mm Head Pins)	0.145"	1" to 1-1/4" (27mm to 32mm)	●	●	●	●	●	●	●	●	●	●	●	●	
	Rebar/Dowel Basket Clip (8mm Head Pins)	0.145"	37mm to 64mm (1-1/2" to 2-1/2")	●	●	●	○	○	●	●	●	●	●	●	●	

● Suitable ○ May be Suitable

SECTION CONTENTS

General Information..... 1
 Selection Guide..... 1
 Performance Data..... 2
 Ordering Information..... 4



THREADED STUDS



ROD HANGERS



POST NUT HANGERS - STANDARD AND EXTENDED LENGTH (XL)



BX & EMT CONDUIT CLIPS



REBAR/DOWEL BASKET CLIPS

SUITABLE BASE MATERIALS

- Normal-weight concrete
- Lightweight concrete
- Concrete over steel deck
- Grouted concrete masonry (CMU)
- Hollow concrete masonry (CMU)
- Steel

FASTENER SIZE RANGE

- 7/8" length through 1-1/4" length

CODE LISTED
ICC-ES ESR-2024
CONCRETE, MASONRY, STEEL

PERFORMANCE DATA

Allowable Load Capacities for Powder Actuated Fasteners in ASTM A36 Steel^{1,2,3,4}

Fastener Description	Shank Type	Nominal Steel Thickness							
		1/8"		3/16"		1/4"		3/8"	
		Tension lbs. (kN)	Shear lbs. (kN)	Tension lbs. (kN)	Shear lbs. (kN)	Tension lbs. (kN)	Shear lbs. (kN)	Tension lbs. (kN)	Shear lbs. (kN)
1/4"-20 Threaded Stud (0.145" Shank)	Knurled	220 (1.0)	445 (2.0)	465 (2.1)	495 (2.2)	565 (2.5)	545 (2.4)	510 (2.3)	750 (3.3)
3/8"-16 Threaded Stud (0.205" Shank)	Knurled	225 (1.0)	555 (2.5)	540 (2.4)	590 (2.6)	745 (3.3)	620 (2.8)	-	-

1. The allowable tension and shear values are for fasteners only. Steel or wood members connected to the substrate must be investigated for compliance with the applicable code.
2. Allowable load capacities are calculated using minimum required factors of safety in accordance with ICC-ES AC70; the minimum applied factor of safety is 5.0. Consideration of additional safety factors may be necessary depending on the application such as life safety.
3. Fasteners must be driven to obtain an embedment equivalent to the nominal steel thickness with the point of the fastener penetrating through the steel base material.
4. Multiple fasteners are recommended for any attachment for increased reliability.

Allowable Load Capacities for Powder Actuated Fasteners in Normal-Weight Concrete^{1,2,3,4,5,6,7}

Fastener Description	Minimum Embed. Depth in. (mm)	Minimum Concrete Compressive Strength (f'c)								
		2,000 psi		3,000 psi		4,000 psi		5,000 psi		
		Tension lbs. (kN)	Shear lbs. (kN)	Tension lbs. (kN)	Shear lbs. (kN)	Tension lbs. (kN)	Shear lbs. (kN)	Tension lbs. (kN)	Shear lbs. (kN)	
1/4"-20 Threaded Stud (0.145" Shank)	5/8 (15.9)	25 (0.1)	45 (0.2)	60 (0.3)	95 (0.4)	45 (0.2)	95 (0.4)	25 (0.1)	95 (0.4)	
	3/4 (19.1)	60 (0.3)	95 (0.4)	95 (0.4)	125 (0.6)	95 (0.4)	125 (0.6)	100 (0.4)	125 (0.6)	
	1 (25.4)	100 (0.4)	140 (0.6)	130 (0.6)	155 (0.7)	155 (0.7)	155 (0.7)	180 (0.8)	200 (0.9)	
	1-1/4 (31.8)	110 (0.5)	155 (0.7)	155 (0.7)	165 (0.7)	195 (0.9)	165 (0.7)	235 (1)	200 (0.9)	
3/8"-16 Threaded Stud (0.205" Shank)	1 (25.4)	95 (0.4)	135 (0.6)	80 (0.4)	135 (0.6)	160 (0.7)	110 (0.5)	160 (0.7)	110 (0.5)	
	1-1/4 (31.8)	170 (0.8)	220 (1)	165 (0.7)	220 (1)	200 (0.9)	320 (1.4)	200 (0.9)	320 (1.4)	
0.300" Head Drive Pin with Post Nut Hanger (0.145" Shank)	Regular Length Clips	1 (25.4)	105 (0.5)	195 (0.9)	160 (0.7)	240 (1.1)	185 (0.8)	245 (1.1)	-	-
		1-1/8 (28.6)	110 (0.5)	215 (1.0)	165 (0.7)	255 (1.1)	205 (0.9)	275 (1.2)	-	-
	Extended Length (XL)	1 (25.4)	135 (0.6)	250 (1.1)	165 (0.7)	280 (1.2)	245 (1.1)	280 (1.2)	-	-
8mm Head Drive Pin with Rod Hanger (0.145" Shank)	1 (25.4)	-	-	120 (0.5)	-	120 (0.5)	-	-	-	

1. Fasteners must not be driven until the concrete has reached the minimum designated compressive strength. Linear interpolation may be used to determine allowable loads for intermediate compressive strengths.
2. Concrete thickness must be a minimum of three times the embedment depth.
3. The allowable tension and shear values are for fasteners only. Steel or wood members connected to the substrate must be investigated for compliance with the applicable code.
4. Allowable load capacities are calculated using minimum required factors of safety in accordance with ICC-ES AC70; the minimum applied factor of safety is 5.0. Consideration of additional safety factors may be necessary depending on the application such as life safety.
5. Fasteners must have a minimum spacing distance of 3 inches for 0.145-inch shank fasteners, 4 inches for 0.157-inch shank fasteners and 6 inches for 0.205" shank fasteners in accordance with ASTM E 1190.
6. Minimum edge distance is 3 inches for 0.145-inch shank fasteners and 3-1/2 inches for 0.157-inch shank fasteners and 0.205-inch shank fasteners. Consideration of smaller spacing and edge distances may be given based on application or jobsite testing.
7. Multiple fasteners are recommended for any attachment for increased reliability.

POWDER ACTUATED

THREADED STUDS, ROD HANGERS

Allowable Load Capacities for Powder Actuated Fasteners in Lightweight Concrete and Sand-Lightweight Concrete over Steel Deck (3,000 psi)^{1,2,3,9,10}

Fastener Description	Minimum Embed. Depth in. (mm)	Minimum Concrete Compressive Strength (f'c)					
		Directly into Concrete ^{4,5,6}		Through Soffit of Steel Deck into Concrete ^{5,7,8}			
		Tension lbs. (kN)	Shear lbs. (kN)	Lower Flute		Upper Flute	
				Tension lbs. (kN)	Shear lbs. (kN)	Tension lbs. (kN)	Shear lbs. (kN)
1/4"-20 Threaded Stud (0.145" Shank)	1 (25.4)	70 (0.3)	35 (0.2)	35 (0.2)	160 (0.7)	35 (0.2)	160 (0.7)
	1-1/4 (31.8)	70 (0.3)	125 (0.6)	65 (0.3)	170 (0.8)	65 (0.3)	170 (0.8)
3/8"-16 Threaded Stud (0.205" Shank)	1 (25.4)	70 (0.3)	130 (0.6)	45 (0.2)	165 (0.7)	45 (0.2)	165 (0.7)
	1-1/4 (31.8)	170 (0.8)	265 (1.2)	85 (0.4)	225 (1)	85 (0.4)	225 (1)

- Fasteners must not be driven until the concrete has reached the minimum designated compressive strength.
- The tension and shear values are for fasteners only. Steel or wood members connected to the substrate must be investigated for compliance with the applicable code.
- Allowable load capacities are calculated using minimum required factors of safety in accordance with ICC-ES AC70; the minimum applied factor of safety is 5.0. Consideration of additional safety factors may be necessary depending on the application such as life safety.
- For fasteners installed directly into concrete, the member thickness must be a minimum of 3.25 inches.
- Fasteners must have a minimum spacing distance of 3 inches for 0.145-inch shank fasteners and 6 inches for 0.205" shank fasteners in accordance with ASTM E 1190.
- Minimum edge distance is 3 inches for 0.145-inch shank fasteners and 3-1/2 inches for 0.205-inch shank fasteners. Consideration of smaller spacing and edge distances may be given based on application or jobsite testing.
- For fasteners installed into the upper flute of the steel deck profile the concrete thickness above the deck (topping thickness) must be a minimum of 3.25 inches; or for fasteners installed into the lower flute of the steel deck profile, the concrete thickness above the deck (topping thickness) must be a minimum of 2.25 inches.
- Fasteners installed into the soffit of the steel deck profile must have a minimum edge distance of 1-1/8 inches (lower flute); minimum deck end distance is 3 inches for 0.145-inch shank fasteners and 3-1/2 inches for 0.205-inch shank fasteners. Consideration of smaller spacing distances may be given based on application or jobsite testing.
- Embedment is measured from the surface of the steel deck; the steel deck panel must have a base-metal thickness of 0.030-inch (22 gauge) to 0.048-inch (18 gauge).
- Multiple fasteners are recommended for any attachment for increased reliability.

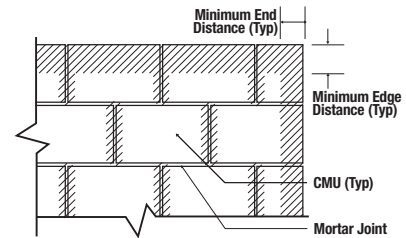
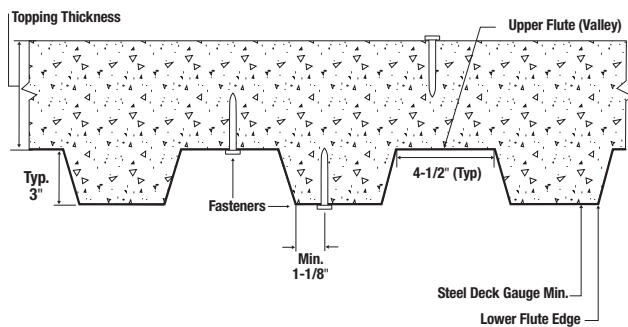

Wall Face Permissible Anchor Locations (Un-hatched Area)

Allowable Load Capacities for Powder Actuated Fasteners in Concrete Masonry (f'm ≥ 1,500 psi)^{1,2,3,4,9,10,11}

Fastener Description	Shank Diameter (inch)	Embed. Depth in. (mm)	Hollow CMU ^{4,5}				Grouted CMU ^{6,7,8}			
			Face Shell		Horizontal Mortar Joint		Face Shell		Horizontal Mortar Joint	
			Tension lbs. (kN)	Shear lbs. (kN)	Tension lbs. (kN)	Shear lbs. (kN)	Tension lbs. (kN)	Shear lbs. (kN)	Tension lbs. (kN)	Shear lbs. (kN)
1/4" - 20 Threaded Stud	0.145	1 (25.4)	185 (0.8)	180 (0.8)	60 (0.3)	120 (0.5)	175 (0.8)	220 (1.0)	135 (0.6)	220 (1.0)
3/8"-16 Threaded Stud	0.205	1 (25.4)	20 (0.1)	85 (0.4)	-	-	110 (0.5)	185 (0.8)	135 (0.6)	130 (0.6)

- Fasteners must not be driven until the masonry has reached the minimum designated compressive strength. Concrete masonry must be minimum 8-inch wide, minimum Grade N, Type II, lightweight, medium-weight or normal-weight units conforming to ASTM C90. Mortar must be minimum Type N complying with ASTM C270. Grout must be coarse grout complying with ASTM C476.
- The tabulated tension and shear values are for the fasteners only. Steel or wood members connected with the substrate must be investigated for compliance with the applicable code.
- Allowable load capacities are calculated using minimum required factors of safety in accordance with ICC-ES AC70; the minimum applied factor of safety is 5.0. Consideration of additional safety factors may be necessary depending on the application such as life safety.
- Fasteners installed into the face or end of hollow CMU must have a minimum end distance of 3-3/4 inches. No more than one fastener may be installed in an individual hollow concrete masonry unit cell.
- For installations into hollow CMU walls, 3/8"-16 threaded stud fasteners may not be placed into the mortar joint.
- Fasteners installed into grout-filled concrete masonry must have a minimum spacing distance of 4 inches and a minimum edge distance 3-3/4 inches.
- For installations into grout-filled concrete masonry walls, fasteners may be placed into the bed joint (horizontal mortar joint) provided the fasteners have a minimum spacing distance of 8 inches along the bed joint and have a minimum edge distance of 8 inches.
- Installations directly into the head joint (vertical mortar joint) and within 1-1/2 inch of the head joint is not recommended and must not be permitted.
- Allowable shear loads may be applied in any direction.
- Multiple fasteners are recommended for any attachment for increased reliability.
- Successful fastening into the face shell of hollow CMU and into the horizontal mortar joint is typically conducted with the lowest powder load level.

ORDERING INFORMATION

POWDER ACTUATED

THREADED STUDS, ROD HANGERS

1/4"-20 Threaded Studs (UNC Thread)

Cat. No.	Thread Length	Shank Length	Shank Dia.	Pack Qty.	Carton Qty.
50322-PWR	3/4"	1/2" (K)	0.145"	100	1,000
50326-PWR	3/4"	3/4"	0.145"	100	1,000
50330-PWR	3/4"	1"	0.145"	100	1,000

(K) = knurled



3/8"-16 Threaded Studs (UNC Thread)

Cat. No.	Thread Length	Shank Length	Shank Dia.	Pack Qty.	Carton Qty.
50342-PWR	1-1/4"	1"	0.205"	100	1,000
50344-PWR	1-1/4"	1-1/4"	0.205"	100	1,000

(K) = knurled



CSI Spiral and 8mm Head Drive Pins with Rod Hanger (UNC Thread)

Cat. No.	Hanger Size	Shank Length	Shank Dia.	Pack Qty.	Carton Qty.
50219-PWR	1/4"-20	32mm (1-1/4")	0.145"	100	1,000
50221-PWR	3/8"-16	32mm (1-1/4")	0.145"	100	1,000



0.300" Head Drive Pins with Post Nut Rod Hanger (UNC Thread)

Cat. No.	Hanger Size	Shank Length	Shank Dia.	Pack Qty.	Carton Qty.
50378-PWR	1/4"-20 (domed right angle clip)	1-1/4"	0.145"	100	1,000
DFD3389	1/4"-20 (XL right angle clip)	1-1/4"	0.145"	50	500

XL = Extended Length

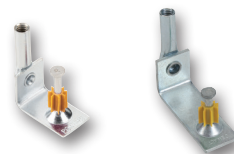

0.300" Head Drive Pins with BX Cable Straps

Cat. No.	Clip Size	Shank Length	Shank Dia.	Pack Qty.	Carton Qty.
50150-PWR	Std. BX Clip	1"	0.145"	100	1,000



0.300" Head Pins with Conduit Clips

Cat. No.	Clip Size	Shank Length	Shank Dia.	Pack Qty.	Carton Qty.
50382-PWR	1/2" EMT (domed clip)	1"	0.145"	100	1,000
50384-PWR	3/4" EMT (domed clip)	1-1/4"	0.145"	100	500



8mm Head Drive Pins with EMT Conduit Clips

Cat. No.	Clip Size	Shank Length	Shank Dia.	Pack Qty.	Carton Qty.
50278-PWR	3/4" EMT	27mm (1")	0.145"	100	500
50280-PWR	1" EMT	27mm (1")	0.145"	25	250



8mm Head Drive Pins with Rebar/Dowel Basket Clips

Cat. No.	Clip Size	Shank Length	Shank Dia.	Pack Qty.	Carton Qty.
50704-PWR	Std. basket clip	37mm (1-1/2")	0.145"	100	100
50712-PWR	Std. basket clip	52mm (2")	0.145"	100	100
50716-PWR	Std. basket clip	62mm (2-1/2")	0.145"	100	100

