

# ICC-ES Evaluation Report

ESR-3298

Reissued July 2025

This report also contains:

- [City of LA Supplement](#)

Subject to renewal July 2026



- [FL Supplement w/ HVHZ](#)

*For references to other reports.*

- See [ELC-3298](#) for [National Building Code of Canada](#)

ICC-ES Evaluation Reports are not to be construed as representing aesthetics or any other attributes not specifically addressed, nor are they to be construed as an endorsement of the subject of the report or a recommendation for its use. There is no warranty by ICC Evaluation Service, LLC, express or implied, as to any finding or other matter in this report, or as to any product covered by the report.

Copyright © 2025 ICC Evaluation Service, LLC. All rights reserved.

<p><b>DIVISION: 03 00 00—</b> <b>CONCRETE</b></p> <p><b>Section: 03 16 00—</b> <b>Concrete Anchors</b></p> <p><b>DIVISION: 05 00 00—</b> <b>METALS</b></p> <p><b>Section: 05 05 19—</b> <b>Post-Installed Concrete Anchors</b></p>	<p><b>REPORT HOLDER:</b> <b>DEWALT</b></p> 	<p><b>EVALUATION SUBJECT:</b></p> <p><b>PURE110+® EPOXY ADHESIVE ANCHOR SYSTEM AND POST-INSTALLED REINFORCING BAR CONNECTIONS IN CRACKED AND UNCRACKED CONCRETE (DEWALT)</b></p>	
--	--	--	---

## 1.0 EVALUATION SCOPE

### Compliance with the following codes:

- 2024, 2021, 2018 and 2015 [International Building Code® \(IBC\)](#)
- 2024, 2021, 2018 and 2015 [International Residential Code® \(IRC\)](#)

Main references of this report are for the 2024 IBC and IRC. See [Table 15](#) and [Table 16](#) for applicable sections of the code for previous IBC and IRC editions.

### Property evaluated:

- Structural

## 2.0 USES

The Pure110+ Epoxy Adhesive Anchor System and Post-Installed Reinforcing Bar Connections are used as anchorage in cracked and uncracked normal-weight concrete or lightweight concrete with a specified compressive strength,  $f'_c$ , of 2,500 psi to 8,500 psi (17.2 MPa to 58.6 MPa) to resist static, wind or earthquake (IBC Seismic Design Categories A through F) tension and shear loads.

The anchor system complies with anchors as described in Section 1901.3 of the 2024 IBC. The anchor systems may also be used where an engineered design is submitted in accordance with Section R301.1.3 of the IRC. The post-installed reinforcing bar connections are an alternative to cast-in-place reinforcing bars governed by ACI 318-19 and IBC Chapter 19.

## 3.0 DESCRIPTION

### 3.1 General:

The Pure110+ Epoxy Adhesive System is comprised of a two-component epoxy adhesive filled in cartridges, static mixing nozzles, dispensing tools, hole cleaning equipment and adhesive injection accessories. The Pure110+ epoxy adhesive system may be used with continuously threaded steel rods or deformed steel reinforcing bars to form the Pure110+ Epoxy Adhesive Anchor System (see [Table 1A](#) and [Figure 1](#) of this report) or with deformed steel reinforcing bars to form the Pure110+ Epoxy Adhesive Post-Installed Reinforcing Bar Connections (see [Table 1B](#), [Figure 1](#) and [Figure 3](#) of this report). Product name for the report holder is presented in the following.

COMPANY NAME	PRODUCT NAME
DEWALT	Pure110+ <sup>®</sup>
	Pure110-PRO (outside the Americas)

The adhesive and steel anchor elements (continuously threaded steel rods or deformed steel reinforcing bars) are installed in pre-drilled holes into concrete. The primary components of the Pure110+ Epoxy Adhesive Anchor System and Post-Installed Reinforcing Bar Connections, including the epoxy adhesive cartridge, static mixing nozzle, the nozzle extension tube, dispensing tool and typical steel anchor elements, are shown in [Figure 2](#) of this report. Manufacturer's printed installation instructions (MPII) and parameters, included with each adhesive unit package, are shown in [Figure 4A](#) and [4B](#).

### 3.2 Materials:

**3.2.1 Pure110+ Epoxy Adhesive:** Pure110+ epoxy adhesive is an injectable two-component epoxy. The two components are separated by means of a labelled dual-cylinder cartridge. The two components combine and react when dispensed through a static mixing nozzle, supplied by DEWALT, which is attached to the cartridge. The Pure110+ epoxy adhesive is available in 9-ounce (265 mL), 9.5-ounce (280 mL), 13.5-ounce (400 mL), 20.5-ounce (610 mL) and 50.5-ounce (1500 mL) cartridges. Each cartridge label is marked with the adhesive expiration date. The shelf life, as indicated by the expiration date, applies to an unopened cartridge when stored in accordance with the manufacturer's printed installation instructions (MPII) as illustrated in [Figure 4A](#) and [4B](#) of this report.

**3.2.2 Hole Cleaning Equipment:** Standard hole cleaning equipment and dust extraction system equipment (i.e. suction, vacuum) are available from the report holder.

**3.2.2.1 Standard Hole Cleaning:** Standard hole cleaning equipment used after drilling is comprised of steel wire brushes supplied by DEWALT and a compressed air nozzle (applicable for both post-installed adhesive anchor system and post-installed reinforcing bar connections). Standard hole cleaning equipment is shown in [Figure 4A](#) and [4B](#).

**3.2.2.2 DustX+™ Extraction System:** The DustX+™ extraction system automatically cleans the holes during drilling using hollow drill bits with a carbide head meeting the requirements of ANSI B212.15 and a DEWALT DWV012 / DWV902M vacuum equipped with an automatic filter cleaning system or equivalent as approved by DEWALT (applicable for post-installed adhesive anchors and post-installed reinforcing bar connections). After drilling with the DustX+™ system, no further hole cleaning is required. See [Figure A](#) for illustration of the DustX+™ extraction system.

**3.2.3 Dispensers** Pure110+ epoxy adhesive must be dispensed with manual dispensers, pneumatic dispensers, or electric powered dispensers supplied by DEWALT.

### 3.2.4 Steel Anchor Elements:

**3.2.4.1 Threaded Steel Rods:** Threaded steel rods must be clean and continuously threaded (all-thread) in diameters as described in [Tables 4](#) and [8](#) of this report. The embedded portions of threaded rods must be clean, straight, and free of mill scale, rust and other coatings (other than zinc) that may impair the bond with the adhesive. Threaded rods, matching nuts and washers must comply with the requirements including specifications, grades, and mechanical properties prescribed in [Table 2](#) of this report. Carbon steel threaded rods may be furnished with a 0.0002-inch-thick (0.005 mm) zinc electroplated coating complying with ASTM B633, SC1; or a minimum 0.0021-inch-thick (0.053 mm) mechanically deposited zinc coating complying with ASTM B695, Class 55; or a hot dip galvanized zinc coating complying with ASTM A153, Class C or D. Steel grades and material types (carbon, stainless) of the washers and nuts must be matched to the threaded rods. Threaded steel rods must be straight and free of indentations or other defects along their length. The embedded end may be either flat cut or cut on the bias to a chisel point.

**3.2.4.2 Steel Reinforcing Bars:** Steel reinforcing bars must be deformed reinforcing bars (rebars) as described in [Table 3](#) of this report. [Tables 1A](#), [5](#), [6](#), [7](#), [9](#), [10](#) and [11](#) summarize reinforcing bar size ranges. The embedded portions of reinforcing bars must be clean, straight, and free of mill scale, rust and other coatings (other than zinc) that may impair the bond with the adhesive. Reinforcing bars must not be bent after installation, except as set forth in ACI 318-19 Section 26.6.3.2 (b), with the additional condition that the bars must be bent cold, and heating of the reinforcing bars to facilitate field bending is not permitted.

**3.2.4.3 Ductility:** In accordance with ACI 318-19 Section 2.3, in order for a steel anchor element to be considered ductile, the tested elongation must be at least 14 percent and the reduction of area must be at least 30 percent. Steel elements with a tested elongation of less than 14 percent or a reduction of area less than 30 percent, or both, are considered brittle. Values for various steel materials are provided in [Tables 2](#) and [3](#) of this report. Where values are nonconforming or unstated, the steel element must be considered brittle.

**3.2.5 Steel Reinforcing Bars for Use in Post-Installed Reinforcing Bar Connections:** Steel reinforcing bars used in post-installed reinforcing bar connections must be deformed bars (rebar) as depicted in [Figure 3](#).

Tables 1B and 13 summarize reinforcing bar size ranges. The embedded portions of reinforcing bars must be straight, and free of mill scale, rust, mud, oil, and other coatings (other than zinc) that may impair the bond with the adhesive. Reinforcing bars must not be bent after installation, except as set forth in ACI 318-19 Section 26.6.3.2 (b), with the additional condition that the bars must be bent cold, and heating of reinforcing bars to facilitate field bending is not permitted.

**3.3 Concrete:**

Normalweight concrete and lightweight concrete must comply with Sections 1903 and 1905 of the IBC, as applicable. The specified compressive strength of the concrete must be from 2,500 psi to 8,500 psi (17.2 MPa to 58.6 MPa).

**4.0 DESIGN AND INSTALLATION**

**4.1 Strength Design of Pure110+ Epoxy Adhesive Post-installed Adhesive Anchor System:**

**4.1.1 General:** The design strength of anchors under the 2024 IBC, as well as the 2024 IRC must be determined in accordance with ACI 318-19 and this report.

The strength design of anchor system must comply with ACI 318-19 Section 17.5.1.2, except as required in ACI 318-19 Section 17.10.

Design parameters are provided in Table 4 through Table 11. Strength reduction factors,  $\phi$ , as given in ACI 318-19 Section 17.5.3, must be used for load combinations calculated in accordance with Section 1605.1 of the 2024 IBC and ACI 318-19 Section 5.3.

**4.1.2 Static Steel Strength in Tension:** The nominal static steel strength of a single anchor in tension,  $N_{sa}$ , in accordance with ACI 318-19 Section 17.6.1.2 and the associated strength reduction factors,  $\phi$ , in accordance with ACI 318-19 Section 17.5.3, are provided in Tables 4, 5, 8 and 9 of this report for the corresponding steel anchor element. See Table 1A for index of design tables.

**4.1.3 Static Concrete Breakout Strength in Tension:** The nominal static concrete breakout strength of a single anchor or group of anchors in tension,  $N_{cb}$  or  $N_{cbg}$ , must be calculated in accordance with ACI 318-19 Section 17.6.2 with the following addition:

The basic concrete breakout strength of a single anchor in tension,  $N_b$ , must be calculated in accordance with ACI 318-19 Section 17.6.2.2, using the selected values of  $k_{c,cr}$  and  $k_{c,uncr}$  as provided in the tables of this report. Where analysis indicates no cracking in accordance with ACI 318-19 Section 17.6.2.5,  $N_b$  must be calculated using  $k_{c,uncr}$  and  $\Psi_{c,N} = 1.0$ . See Table 1A. For anchors in lightweight concrete see ACI 318-19 Section 17.2.4. The value of  $f'_c$  used for calculation must be limited to 8,000 psi (55 MPa) in accordance with ACI 318-19 Section 17.3.1. Additional information for the determination of nominal bond strength in tension is given in Section 4.1.4 of this report.

**4.1.4 Static Bond Strength in Tension:** The nominal static bond strength of a single adhesive anchor or group of adhesive anchors in tension,  $N_a$  or  $N_{ag}$ , must be calculated in accordance with ACI 318-19 Section 17.6.5. Bond strength values ( $\tau_{k,cr}$ ,  $\tau_{k,uncr}$ ) are a function of the concrete service temperature, concrete state (cracked, uncracked), drilling method (hammer-drill, i.e. rotary impact drill or rock drill with a carbide bit), concrete compressive strength ( $f'_c$ ) and installation conditions (dry concrete, water-saturated concrete, water-filled holes, underwater). Special inspection level is qualified as periodic for all anchors except as noted in Section 4.4 of this report. The selection of continuous special inspection level, with an onsite proof loading program, is not necessary and does not provide a benefit of a lower anchor category or an increase in the associated strength reduction factors for design. The following table summarizes the requirements.

CONCRETE STATE	DRILLING METHOD	BOND STRENGTH	CONCRETE STRENGTH	PERMISSIBLE INSTALLATION CONDITIONS	ASSOCIATED STRENGTH REDUCTION FACTOR
Cracked and Uncracked	Hammer-drill with carbide drill bit or DEWALT hollow bit	$\tau_{k,cr}$ OR	$f'_c$	Dry concrete	$\phi_d$
				Water-saturated concrete	$\phi_{ws}$
	$\tau_{k,uncr}$	Water-filled hole (flooded)		$\phi_{wf}$	
		Underwater (submerged)		$\phi_{uw}$	

The bond strength values in this report, correspond to concrete compressive strength  $f'_c$  equal to 2,500 psi (17.2 MPa). For concrete compressive strength,  $f'_c$ , between 2,500 psi and 8,000 psi (17.2 MPa and 55.2 MPa), the tabulated characteristic bond strength may be increased by a factor of  $(f'_c / 2,500)^{0.23}$  [For **SI**:  $(f'_c / 17.2)^{0.23}$ ]. Where applicable, the modified bond strength values must be used in lieu of  $\tau_{k,cr}$  and  $\tau_{k,uncl}$  in ACI 318-19 Eq. 17.6.5.1.2b and 17.6.5.2.1. The resulting nominal bond strength must be multiplied by the associated strength reduction factor  $\phi_{mn}$ .

Figure 1 of this report presents a bond strength design selection flowchart. Strength reduction factors for determination of the bond strength are given in Tables 7 and 11 of this report (see Table 1A for an index of design tables). Adjustments to the bond strength may also be taken for increased concrete compressive strength as noted in the footnotes to the corresponding tables. For anchors in lightweight concrete see ACI 318-19 Section 17.2.4.

**4.1.5 Static Steel Strength in Shear:** The nominal static steel strength of a single anchor in shear as governed by the steel,  $V_{sa}$ , in accordance with ACI 318-19 Section 17.7.1.2, and strength reduction factors,  $\phi$ , in accordance with ACI 318-19 Section 17.5.3, are given in Tables 4, 5, 8 and 9 of this report for the anchor element types included herein.

**4.1.6 Static Concrete Breakout Strength in Shear:** The nominal concrete breakout strength of a single anchor or group of anchors in shear,  $V_{cb}$  or  $V_{cbg}$ , must be calculated in accordance with ACI 318-19 Section 17.7.2, based on information given in Table 6 and 10 of this report. The basic concrete breakout strength in shear of a single anchor in cracked concrete,  $V_b$ , must be calculated in accordance with ACI 318-19 Section 17.7.2.2, using the value of  $d$  given in Tables 4, 5, 8 and 9 of this report in lieu of  $d_a$ . In addition,  $h_{ef}$  must be substituted for  $\ell_e$ . In no case shall  $\ell_e$  exceed  $8d$ . For anchors in lightweight concrete see ACI 318-19 Section 17.2.4. The value of  $f'_c$  must be limited to a maximum of 8,000 psi (55.2 MPa), in accordance with ACI 318-19 Section 17.3.1.

**4.1.7 Static Concrete Pryout Strength in Shear:** The nominal static pryout strength of a single anchor or group of anchors in shear,  $V_{cp}$  or  $V_{cpg}$ , shall be calculated in accordance with ACI 318-19 Section 17.7.3.

**4.1.8 Interaction of Tensile and Shear Forces:** For designs that include combined tension and shear, the interaction of tension and shear loads must be calculated in accordance with ACI 318-19 Section 17.8.

**4.1.9 Minimum Member Thickness  $h_{min}$ , Anchor Spacing  $s_{min}$ , Edge Distance  $c_{min}$ :** In lieu of ACI 318-19 Section 17.9.2, values of  $s_{min}$  and  $c_{min}$  described in this report must be observed for anchor design and installation. The minimum member thicknesses,  $h_{min}$ , described in this report must be observed for anchor design and installation. For adhesive anchors that will remain untorqued, ACI 318-19 Section 17.9.3 applies.

For anchors that will be torqued during installation, the maximum torque,  $T_{max}$ , must be reduced for edge distances of less than five anchor diameters ( $5d$ ).  $T_{max}$  is subject to the edge distance,  $c_{min}$ , and anchor spacing,  $s_{min}$ , and must comply with the following requirements:

MAXIMUM TORQUE SUBJECT TO EDGE DISTANCE			
NOMINAL ANCHOR SIZE, $d$	MIN. EDGE DISTANCE, $c_{min}$	MIN. ANCHOR SPACING, $s_{min}$	MAXIMUM TORQUE, $T_{max}$
All sizes	$5d$	$5d$	$T_{max}$
$\frac{3}{8}$ in. to 1 in. (9.5 mm to 25.4 mm)	1.75 in. (45 mm)	$5d$	$0.45 \cdot T_{max}$
$1\frac{1}{4}$ in. (31.8 mm)	2.75 in. (70 mm)		
10 mm to 27 mm (0.39 in. to 1.06 in.)	45 mm (1.75 in.)	$5d$	$0.45 \cdot T_{max}$
28 mm to 32 mm (1.1 in. to 1.26 in.)	70 mm (2.75 in.)		

For values of  $T_{max}$ , see Table 12 and Figure 4A.

**4.1.10 Critical Edge Distance  $c_{ac}$  and  $\psi_{cp,Na}$ :** The modification factor  $\psi_{cp,Na}$ , must be determined in accordance with ACI 318-19 Section 17.6.5.5, except as noted below:

For all cases where  $c_{Na}/c_{ac} < 1.0$ ,  $\psi_{cp,Na}$  determined from ACI 318-19 Eq. 17.6.5.5.1b, need not be taken less than  $c_{Na}/c_{ac}$ . For all other cases,  $\psi_{cp,Na}$  shall be taken as 1.0.

The critical edge distance,  $c_{ac}$  must be calculated according to ACI 318-19 Eq. 17.6.5.5.1c, in lieu of ACI 318-19 Section 17.9.5.

$$c_{ac} = h_{ef} \cdot \left( \frac{\tau_{k, uncl}}{1160} \right)^{0.4} \cdot \left[ 3.1 - 0.7 \frac{h}{h_{ef}} \right]$$

(ACI 318-19 Eq. 17.6.5.5.1c)

where

$\left[ \frac{h}{h_{ef}} \right]$  need not be taken as larger than 2.4; and where

$\tau_{k,uncr}$  = the characteristic bond strength stated in the tables of this report whereby  $\tau_{k,uncr}$  need not be taken as larger than:

$$\tau_{k,uncr} = \frac{k_{uncr} \sqrt{h_{ef} f'_c}}{\pi d_a} \quad \text{Eq. (4-1)}$$

**4.1.11 Design Strength in Seismic Design Categories C, D, E and F:** In structures assigned to Seismic Design Category (SDC) C, D, E or F under the IBC or IRC, anchor system must be designed in accordance with ACI 318-19 Section 17.10, except as described below.

The nominal steel shear strength,  $V_{sa}$ , must be adjusted by  $\alpha_{V,seis}$  as given in [Tables 4](#) and [5](#) for the corresponding anchor steel. The nominal bond strength  $\tau_{kcr}$  need not be adjusted by  $\alpha_{N,seis}$  since  $\alpha_{N,seis} = 1.0$ .

**4.2 Strength Design of Pure110+ Epoxy Adhesive Post-Installed Reinforcing Bar Connections:**

**4.2.1 General:** The design of straight post-installed deformed reinforcing bars must be determined in accordance with ACI 318-19 rules for cast-in place reinforcing bar development and splices and this report. Examples of typical applications for the use of post-installed reinforcing bars are illustrated in [Figure 3](#) of this report.

**4.2.2 Determination of bar development length  $l_d$ :** Values of  $l_d$  must be determined in accordance with the ACI 318-19 development and splice length requirements for straight cast-in place reinforcing bars.

**Exceptions:**

1. For uncoated and zinc-coated (galvanized) post-installed reinforcing bars, the factor  $\Psi_e$  shall be taken as 1.0. For all other cases, the requirements in ACI 318-19 Section 25.4.2.5 shall apply.
2. When using alternate methods to calculate the development length (e.g., anchor theory), the applicable factors for post-installed anchors generally apply.

**4.2.3 Minimum Member Thickness,  $h_{min}$ , Minimum Concrete Cover,  $c_{c,min}$ , Minimum Concrete Edge Distance,  $c_{b,min}$ , Minimum Spacing,  $s_{b,min}$ :** For post-installed reinforcing bars, there is no limit on the minimum member thickness. In general, all requirements on concrete cover and spacing applicable to straight cast-in bars designed in accordance with ACI 318-19 shall be maintained.

For post-installed reinforcing bars installed at embedment depths,  $h_{ef}$ , larger than  $20d_b$  ( $h_{ef} > 20d_b$ ), the minimum concrete cover shall be as follows:

REBAR SIZE	MINIMUM CONCRETE COVER, $c_{c,min}$
$d_b \leq$ No. 6 (16 mm)	1 <sup>1</sup> / <sub>8</sub> in. (29 mm)
No. 6 < $d_b \leq$ No. 11 (16 mm < $d_b \leq$ 36 mm)	1 <sup>9</sup> / <sub>16</sub> in. (40 mm)

The following requirements apply for minimum concrete edge and spacing for  $h_{ef} > 20 d_b$ :

Required minimum edge distance for post-installed reinforcing bars (measured from the center of the bar):

$$c_{b,min} = d_0/2 + c_{c,min}$$

Required minimum center-to-center spacing between post-installed bars:

$$s_{b,min} = d_0 + c_{c,min}$$

Required minimum center-to-center spacing from existing (parallel) reinforcing:

$$s_{b,min} = d_b/2 \text{ (existing reinforcing)} + d_0/2 + c_{c,min}$$

All other requirements applicable to straight cast-in place bars designed in accordance with ACI 318-19 shall be maintained.

**4.2.4 Design Strength in Seismic Design Categories C, D, E and F:** In structures assigned to SDC C, D, E or F under the IBC or IRC, design of straight post-installed reinforcing bars must take into account the provisions of ACI 318-19 Chapter 18.

### 4.3 Allowable Stress Design (ASD):

**4.3.1 General:** For anchor system designed using load combinations in accordance with Section 1605.1 of the 2024 IBC (Allowable Stress Design), allowable loads must be established using Eq. (4-2) and Eq. (4-3):

$$T_{allowable,ASD} = \phi N_n / \alpha \quad \text{Eq. (4-2)}$$

and

$$V_{allowable,ASD} = \phi V_n / \alpha \quad \text{Eq. (4-3)}$$

where

$T_{allowable,ASD}$  = Allowable tension load (lbf or kN).

$V_{allowable,ASD}$  = Allowable shear load (lbf or kN).

$\phi N_n$  = Lowest design strength of an anchor or anchor group in tension as determined in accordance with ACI 318-19 Chapter 17, 2024 IBC Section 1905.7, and Section 4.1 of this report, as applicable (lbf or kN).

$\phi V_n$  = Lowest design strength of an anchor or anchor group in shear as determined in accordance with ACI 318-19 Chapter 17, 2024 IBC Section 1905.7, and Section 4.1 of this report, as applicable (lbf or kN).

$\alpha$  = Conversion factor calculated as a weighted average of the load factors for the controlling load combination. In addition,  $\alpha$  must include all applicable factors to account for non-ductile failure modes and required over-strength.

The requirements described in this report for member thickness, edge distance and spacing, must apply.

**4.3.2 Interaction of Tensile and Shear Forces:** Interaction must be calculated in accordance with ACI 318-19 Section 17.8 as follows:

For shear loads  $V \leq 0.2 V_{allowable,ASD}$ , the full allowable load in tension shall be permitted.

For tension loads  $T \leq 0.2 T_{allowable,ASD}$ , the full allowable load in shear shall be permitted.

For all other cases:

$$\frac{T}{T_{allowable,ASD}} + \frac{V}{V_{allowable,ASD}} \leq 1.2 \quad \text{Eq. (4-4)}$$

### 4.4 Installation:

Installation parameters are illustrated in [Table 12](#) of this report for post-installed adhesive anchor system and [Table 14](#) for post-installed reinforcing bar connections. Installation must be in accordance with ACI 318-19 Section 26.7.2. Anchor and post-installed reinforcing bar locations must comply with this report and the plans and specifications approved by the code official. Installation of the Pure110+ Epoxy Adhesive Anchor System and Post-installed Reinforcing Bar Connections must be in accordance with the Manufacturer's printed installation instructions (MPII) included in each unit package as reproduced in [Figure 4A](#) and [4B](#) of this report.

The adhesive anchor system may be used for upwardly inclined orientation applications (e.g. overhead). Upwardly inclined and horizontal orientation applications are to be installed using piston plugs for the  $5/8$ -inch through  $1\ 1/4$ -inch (M16 through M30) diameter threaded steel rods and No. 5 through No. 10 (14 mm through 32 mm) steel reinforcing bars, installed in the specified hole diameter, and attached to the mixing nozzle and extension tube supplied by DEWALT as described in [Figure 4A](#) and [4B](#) in this report. Upwardly inclined and horizontal orientation installation for the  $3/8$ -inch and  $1/2$ -inch (M10 and M12) diameter threaded steel rods, and No. 3 and No. 4 (10 mm and 12 mm) steel reinforcing bars may be injected directly to the end of the hole using extension tubing attached to the mixing nozzle with a hole depth  $h_0 \leq 10"$  (250 mm).

Installation of anchors in horizontal or upwardly inclined (overhead) orientations shall be fully restrained from movement throughout the specified curing period through the use of temporary wedges, external supports, or other methods. Where temporary restraint devices are used, their use shall not result in impairment of the anchor shear resistance.

### 4.5 Special Inspection:

Periodic special inspection must be performed where required in accordance with Section 1705.1.1 and Table 1705.3 of the 2024 IBC and this report. The special inspector must be on the jobsite initially during

adhesive anchor or post-installed reinforcing bar connection installation to verify anchor or post-installed reinforcing bar type and dimensions, concrete type, concrete compressive strength, adhesive identification and expiration date, hole dimensions, hole cleaning procedures, anchor spacing, edge distances, concrete thickness, adhesive anchor or post-installed reinforcing bar connection embedment, tightening torque and adherence to the manufacturer's printed installation instructions (MPII). The special inspector must verify the initial installations of each type and size of adhesive anchor or post-installed reinforcing bar connection by construction personnel on the site. Subsequent installations of the same anchor type and size by the same construction personnel are permitted to be performed in the absence of the special inspector. Any change in the anchor product being installed or the personnel performing the installation requires an initial inspection. For ongoing installations over an extended period, the special inspector must make regular inspections to confirm correct handling and installation of the product.

Continuous special inspection of adhesive anchors installed in horizontal or upwardly inclined orientations to resist sustained tension loads must be performed in accordance with ACI 318-19 Section 26.13.3.2(e).

Under the IBC, additional requirements as set forth in Section 1705 of the 2024 IBC must be observed, where applicable.

#### 4.6 Compliance with NSF/ANSI Standard 61:

The Pure110+ Epoxy Adhesive Anchor System and Post-installed Reinforcing Bar Connections comply with the requirements of NSF/ANSI Standard 61, as referenced in Section 605 of the 2024 *International Plumbing Code*<sup>®</sup> (IPC), and is certified for use in water distribution systems and may have a maximum exposed surface area to volume ratio of 216 square inches per 1000 gallons (3785 L) for water treatment applications.

## 5.0 CONDITIONS OF USE:

The Pure110+ Epoxy Adhesive Anchor System and Post-installed Reinforcing Bar Connections described in this report comply with or is a suitable alternative to what is specified in the codes listed in Section 1.0 of this report, subject to the following conditions:

- 5.1 Pure110+ epoxy Adhesive Anchors System and Post-installed Reinforcing Bar Connections must be installed in accordance with the Manufacturer's printed installation instructions (MPII) as attached to each cartridge and reproduced in [Figure 4A](#) and [4B](#) of this report.
- 5.2 The Adhesive Anchor System and Post-installed Reinforcing Bar Connections described in this report must be installed in cracked or uncracked normalweight concrete or lightweight concrete having a specified compressive strength,  $f'_c = 2,500$  psi to 8,500 psi (17.2 MPa to 58.6 MPa).
- 5.3 The values of  $f'_c$  used for calculation purposes must not exceed 8,000 psi (55.2 MPa). Steel anchor elements must be installed in concrete base materials in holes predrilled in accordance with the instructions provided in [Figure 4A](#) and [4B](#) of this report.
- 5.4 The concrete shall have attained its minimum design strength prior to installation of the Adhesive Anchor System and Post-installed Reinforcing Bar Connections.
- 5.5 Loads applied to the Adhesive Anchor System and Post-installed Reinforcing Bar Connections must be adjusted in accordance with Section 1605.1 of the 2024 IBC for strength design and for allowable stress design.
- 5.6 Pure110+ epoxy Adhesive Anchors System and Post-installed Reinforcing Bar Connections are recognized for use to resist short and long-term loads, including wind and earthquake, subject to the conditions of this report.
- 5.7 In structures assigned to Seismic Design Categories C, D, E, and F under the IBC or IRC, anchor strength must be adjusted in accordance with Section 4.1.11 of this report, and post-installed reinforcing bars must comply with Section 4.2.4 of this report.
- 5.8 Pure110+ epoxy Adhesive Anchors System and Post-installed Reinforcing Bar Connections are permitted to be installed in concrete that is cracked or that may be expected to crack during the service life of the anchors or post-installed reinforcing bar, subject to the conditions of this report.
- 5.9 Adhesive anchor strength design values must be established in accordance with Section 4.1 of this report.
- 5.10 Post-installed reinforcing bar connection development and splice length is established in accordance with Section 4.2 of this report.
- 5.11 Allowable stress design values must be established in accordance with Section 4.3 of this report.

- 5.12** Minimum anchor spacing and edge distance, as well as minimum member thickness, must comply with the values described in this report.
- 5.13** Post-installed reinforcing bar connection spacing, minimum member thickness, and cover distance must be in accordance with the provisions of ACI 318-19 for cast-in place bars and Section 4.2.3 of this report.
- 5.14** Prior to installation, calculations and details demonstrating compliance with this report must be submitted to the code official. The calculations and details must be prepared by a registered design professional where required by the statutes of the jurisdiction in which the project is to be constructed.
- 5.15** Pure110+ epoxy Adhesive Anchors System and Post-installed Reinforcing Bar Connections are not permitted to support fire-resistive construction. Where not otherwise prohibited by the code, Pure110+ epoxy adhesive anchors and post-installed reinforcing bar connections are permitted for installation in fire-resistive construction provided that at least one of the following conditions is fulfilled:
- Pure110+ epoxy Adhesive Anchors System and Post-installed Reinforcing Bar Connections are used to resist wind or seismic forces only.
  - Pure110+ epoxy Adhesive Anchors System and Post-installed Reinforcing Bar Connections that support gravity load-bearing structural elements are within a fire-resistive envelope or a fire-resistive membrane, are protected by approved fire-resistive materials, or have been evaluated for resistance to fire exposure in accordance with recognized standards.
  - Pure110+ epoxy Adhesive Anchors System and Post-installed Reinforcing Bar Connections are used to support non-structural elements.
- 5.16** Since an ICC-ES acceptance criteria for evaluating data to determine the performance of adhesive anchor system and post-installed reinforcing bar connections subjected to fatigue or shock loading is unavailable at this time, the use of these anchors under such conditions is beyond the scope of this report.
- 5.17** Use of zinc-plated carbon steel threaded rods or steel reinforcing bars for adhesive anchors is limited to dry, interior locations.
- 5.18** Use of hot-dipped galvanized carbon steel and stainless steel threaded rods for adhesive anchors is permitted for exterior exposure or damp environments.
- 5.19** Steel anchoring materials in contact with preservative-treated wood and fire-retardant-treated wood must be of zinc-coated carbon steel or stainless steel. The minimum coating weights for zinc-coated steel must comply with ASTM A153.
- 5.20** Periodic special inspection must be provided in accordance with Section 4.5 of this report. Continuous special inspection of adhesive anchor system and post-installed reinforcing bar connections installed in horizontal or upwardly inclined orientations to resist sustained tension loads must be provided in accordance with Section 4.5 of this report.
- 5.21** Pure110+ epoxy Adhesive Anchors System and Post-installed Reinforcing Bar Connections may be used to resist tension and shear forces in floor, wall and overhead installations into concrete with a temperature between 41°F and 104°F (5°C and 40°C). For overhead and upwardly inclined applications, cartridge temperature must be between 50°F and 90°F (10°C and 32°C). Overhead and upward inclined installations require the use of piston plugs and extension tubing during injection and the adhesive anchor or post-installed reinforcing bar connection system must be supported until fully cured (e.g. wedges or other suitable means). See the MPII in [Figure 4A](#) and [4B](#) of this report for detailed installation requirements, including required installation equipment, procedures, and temperatures.
- 5.22** Installation of adhesive anchor system and post-installed reinforcing bar connections in horizontal or upwardly inclined orientations to resist sustained tension loads must be performed by personnel certified by an applicable certification program in accordance with ACI 318-19 Section 26.7.1(l) and Section 26.7.2(e).
- 5.23** The Pure110+ epoxy adhesive is manufactured under an approved quality-control program with inspections by ICC-ES.

## 6.0 EVIDENCE SUBMITTED

Data in accordance with the [ICC-ES Acceptance Criteria for Post-installed Adhesive Anchors in Concrete AC308 \(24\)](#), published April 2025, which incorporates requirements in ACI 355.4-19 and ACI 355.4-11 for use in cracked and uncracked concrete; including, but not limited to, tests under freeze/thaw conditions, tests under sustained load, tests for installation direction, tests at elevated temperatures, tests for resistance to alkalinity, tests for resistance to sulfur and tests for seismic tension and shear.

## 7.0 IDENTIFICATION

- 7.1 The ICC-ES mark of conformity, electronic labeling, or the evaluation report (ICC-ES ESR-3298) along with the name, registered trademark, or registered logo of the report holder [and/or listee] must be included in the product label.[Electronic labeling is the ICC-ES web address ([www.icc-es.org](http://www.icc-es.org)); specific URL related to the report; or the ICC-ES machine-readable code placed on the aforementioned items.]
- 7.2 In addition, the Pure110+ epoxy adhesive described in Section 3.1 of this report is identified by packaging labeled with the lot number; expiration date; company name (DEWALT); and the evaluation report number (ESR-3298). Threaded rods, nuts, washers and deformed reinforcing bars are standard steel anchor elements and must conform to applicable national or international specifications as set forth in [Tables 2](#) and [3](#) of this report.
- 7.3 The report holder’s contact information is the following:

**DEWALT**  
**701 EAST JOPPA ROAD**  
**TOWSON, MARYLAND 21286**  
**(800) 524-3244**  
[www.DEWALT.com](http://www.DEWALT.com)  
[anchors@DEWALT.com](mailto:anchors@DEWALT.com)

**TABLE 1A—DESIGN USE AND REPORT TABLE INDEX FOR POST-INSTALLED ADHESIVE ANCHORS**

POST-INSTALLED ADHESIVE ANCHORS – COMMON THREADED RODS AND REINFORCING BARS ( <a href="#">Tables 4</a> through <a href="#">11</a> and <a href="#">Figure 1</a> )						
DESIGN STRENGTH <sup>1</sup>		THREADED ROD (FRACTIONAL)	DEFORMED REINFORCING BAR (FRACTIONAL)	THREADED ROD (METRIC)	DEFORMED REINFORCING BAR (METRIC)	
Steel	$N_{sa}, V_{sa}$	<a href="#">Table 4</a>	<a href="#">Table 5</a>	<a href="#">Table 8</a>	<a href="#">Table 9</a>	
Concrete	$N_{cb}, N_{cbg}, V_{cb}, V_{cbg}, V_{cp}, V_{cpg}$	<a href="#">Table 6</a>	<a href="#">Table 6</a>	<a href="#">Table 10</a>	<a href="#">Table 10</a>	
Bond <sup>2</sup>	$N_b, N_{bg}$	<a href="#">Table 7</a>	<a href="#">Table 7</a>	<a href="#">Table 11</a>	<a href="#">Table 11</a>	
Concrete Type	Concrete State	Threaded Rod Diameter (inch)	Reinforcing Bar Size (No.)	Drilling Method <sup>3</sup>	Minimum and Maximum Embedment	Seismic Design Categories <sup>4</sup>
Normal-weight and lightweight	Cracked	$3/8, 1/2, 5/8, 3/4, 7/8, 1, 1 1/4$	3, 4, 5, 6, 7, 8, 9, 10	Hammer-drill	See <a href="#">Table 7</a>	A through F
	Uncracked	$3/8, 1/2, 5/8, 3/4, 7/8, 1, 1 1/4$	3, 4, 5, 6, 7, 8, 9, 10	Hammer-drill	See <a href="#">Table 7</a>	A and B
Concrete Type	Concrete State	Threaded Rod Diameter (mm)	Reinforcing Bar Size (Ø)	Drilling Method <sup>3</sup>	Minimum and Maximum Embedment	Seismic Design Categories <sup>4</sup>
Normal-weight and lightweight	Cracked	10, 12, 16, 20, 24, 27, 30	10, 12, 14, 16, 20, 25, 28, 32	Hammer-drill	See <a href="#">Table 11</a>	A through F
	Uncracked	10, 12, 16, 20, 24, 27, 30	10, 12, 14, 16, 20, 25, 28, 32	Hammer-drill	See <a href="#">Table 11</a>	A and B

For SI: 1 inch = 25.4 mm. For pound-inch units: 1 mm = 0.03937 inch.

<sup>1</sup>Reference ACI 318-19 Section 17.5.1 for post-installed adhesive anchors. The controlling strength is decisive from all appropriate failure modes (i.e. steel, concrete, bond) and design assumptions.

<sup>2</sup>See Section 4.1.4 of this report for bond strength determination of post-installed adhesive anchors.

<sup>3</sup>Hammer-drill, i.e. rotary impact drills or rock drills with a carbide drill bit (including hollow drill bits).

<sup>4</sup>See Section 4.1.11 for requirements for seismic design of post-installed adhesive anchors, where applicable.

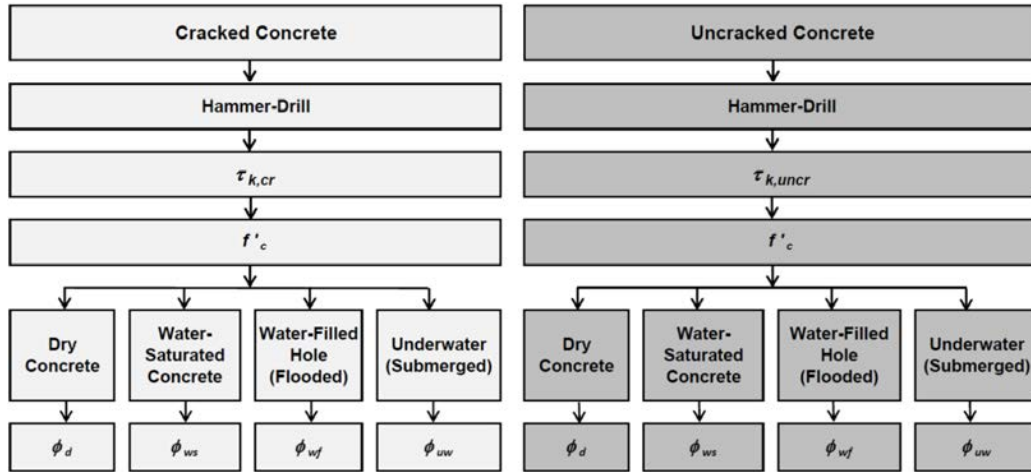

FIGURE 1—FLOWCHART FOR THE ESTABLISHMENT OF DESIGN BOND STRENGTH FOR POST-INSTALLED ADHESIVE ANCHORS

TABLE 1B—DESIGN USE AND REPORT TABLE INDEX FOR POST-INSTALLED REINFORCING BAR CONNECTIONS<sup>1</sup>

POST-INSTALLED REINFORCING BARS See <a href="#">Table 13</a> and <a href="#">Figure 3</a>			
Concrete Type	Reinforcing Bar Size	Drilling Method <sup>2</sup>	Seismic Design Categories <sup>3</sup>
Normal-weight and lightweight	#3, #4, #5, #6, #7, #8, #9, #10, #11	Hammer-drill or core-drill	A through F
	Ø10, Ø12, Ø14, Ø16, Ø20, Ø25, Ø28, Ø32, Ø34, Ø36	Hammer-drill or core-drill	A through F
	10M, 15M, 20M, 25M, 30M, 35M	Hammer-drill or core-drill	A through F

For **SI**: 1 inch = 25.4 mm. For **pound-inch** units: 1 mm = 0.03937 inch.

<sup>1</sup>Determination of development length for post-installed reinforcing bar connections in accordance with this report.

<sup>2</sup>Hammer-drill, i.e. rotary impact drills or rock drills with a carbide drill bit (including hollow drill bits); core-drill, i.e. core drill with a diamond core drill bit.

<sup>3</sup>See Section 4.2.4 for requirements for seismic design of post-installed reinforcing bar connections, where applicable.

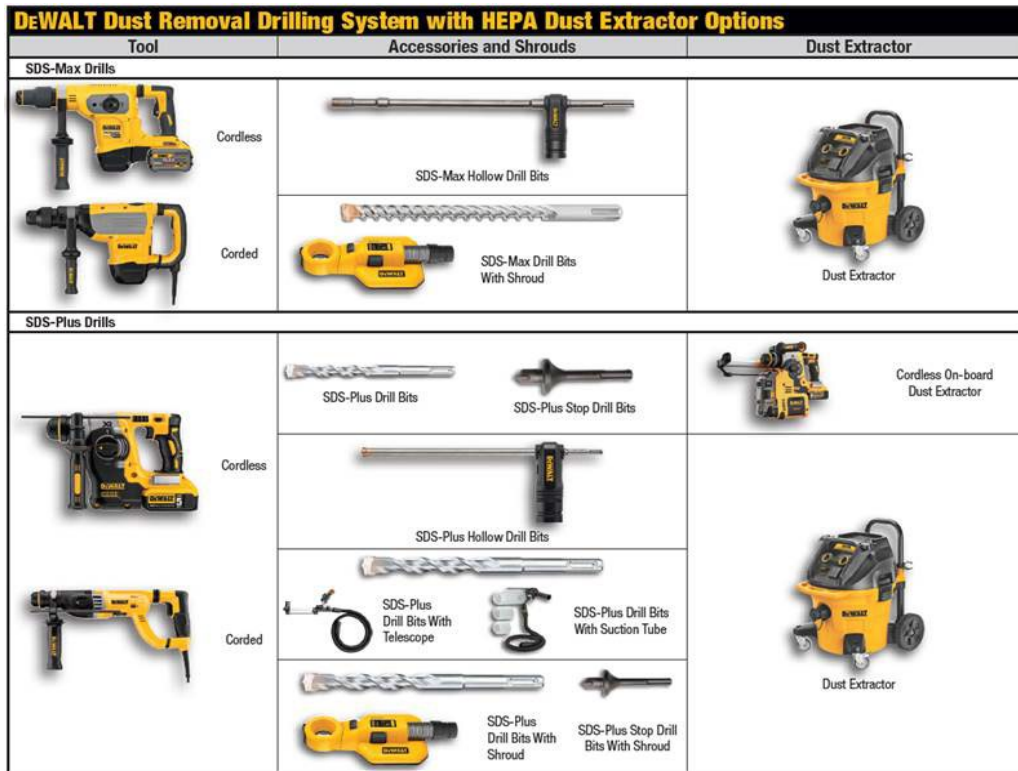

The DEWALT drilling systems shown above collect and remove dust with a HEPA dust extractor during the hole drilling operation in dry base materials using hammer-drills (see step 1 of the manufacturer's published installation instructions - MP11).

FIGURE A—EXAMPLES DEWALT DUST REMOVAL DRILLING SYSTEMS WITH HEPA DUST EXTRACTORS FOR ILLUSTRATION

TABLE 2—SPECIFICATIONS AND PROPERTIES OF COMMON THREADED CARBON AND STAINLESS STEEL ROD MATERIALS<sup>1</sup>

THREADED ROD SPECIFICATION		UNITS	MIN. SPECIFIED ULTIMATE STRENGTH, $f_{uta}$	MIN. SPECIFIED YIELD STRENGTH 0.2 PERCENT OFFSET, $f_{ya}$	$f_{uta}$ — $f_{ya}$	ELONGATION MINIMUM PERCENT <sup>11</sup>	REDUCTION OF AREA MIN. PERCENT	NUT SPECIFICATION <sup>12</sup>
Carbon Steel	ASTM A36 <sup>2</sup> and F1554 <sup>3</sup> Grade 36	psi (MPa)	58,000 (400)	36,000 (248)	1.61	23	40 (50 for A36)	ASTM A194 / A563 Grade A
	ASTM F1554 <sup>3</sup> Grade 55	psi (MPa)	75,000 (517)	55,000 (380)	1.36	23	40	
	ASTM F1554 <sup>3</sup> Grade 105	psi (MPa)	125,000 (862)	105,000 (724)	1.19	15	45	ASTM A194 / A563 Grade DH
	ASTM A193 <sup>4</sup> Grade B7	psi (MPa)	125,000 (860)	105,000 (720)	1.19	16	50	
	ASTM A449 <sup>5</sup> (3/8 to 1 inch dia.)	psi (MPa)	120,000 (828)	92,000 (635)	1.30	14	35	ASTM A194 / A563 Grade DH
	ASTM A449 <sup>5</sup> (1 1/4 inch dia.)	psi (MPa)	105,000 (720)	81,000 (560)	1.30	14	35	
	ASTM F568M <sup>6</sup> Class 5.8 (equivalent to ISO 898-1)	psi (MPa)	72,500 (500)	58,000 (400)	1.25	10	35	ASTM A563 Grade DH DIN 934 (8-A2K) <sup>13</sup>
	ISO 898-17 Class 5.8	MPa (psi)	500 (72,500)	400 (58,000)	1.25	22	- <sup>14</sup>	DIN 934 Grade 6
	ISO 898-17 Class 8.8	MPa (psi)	800 (116,000)	640 (92,800)	1.25	12	52	DIN 934 Grade 8
Stainless Steel	ASTM F593 <sup>8</sup> CW1 (3/8 to 5/8 inch dia.)	psi (MPa)	100,000 (690)	65,000 (450)	1.54	20	- <sup>14</sup>	ASTM F594 Alloy Group 1, 2 or 3
	ASTM F593 <sup>8</sup> CW2 (3/4 to 1 1/4 inch dia.)	psi (MPa)	85,000 (590)	45,000 (310)	1.89	25	- <sup>14</sup>	
	ASTM A193/A193M <sup>9</sup> Grade B8/B8M, Class 1	psi (MPa)	75,000 (515)	30,000 (205)	2.50	30	50	ASTM A194/A194M
	ASTM A193/A193M <sup>9</sup> Grade B8/B8M2, Class 2B	psi (MPa)	95,000 (655)	75,000 (515)	1.27	25	40	
	ISO 3506-1 <sup>10</sup> A4-70 and HCR-70 (M8 – M24)	MPa (psi)	700 (101,500)	450 (65,250)	1.56	40	- <sup>14</sup>	ISO 4032
	ISO 3506-1 <sup>10</sup> A4-50 and HCR-50 (M27 – M30)	MPa (psi)	500 (72,500)	210 (30,450)	2.38	40	- <sup>14</sup>	

For **SI**: 1 inch = 25.4 mm, 1 psi = 0.006897 MPa. For **pound-inch** units: 1 mm = 0.03937 inch, 1 MPa = 145.0 psi.

<sup>1</sup>Pure 110+ epoxy adhesive may be used in conjunction with all grades of continuously threaded carbon or stainless steels (all-thread) that comply with this table and that have thread characteristics comparable with ANSI B1.1 UNC Coarse Thread Series or ANSI B1.13M M Profile Metric Thread Series. Tabulated values correspond to anchor diameters included in this report. See Section 3.2.4.3 of this report for ductility of steel anchor elements.

<sup>2</sup>Standard Specification for Carbon Structural Steel.

<sup>3</sup>Standard Specification for Anchor Bolts, Steel, 36, 55, and 105-ksi Yield Strength.

<sup>4</sup>Standard Specification for Alloy-Steel and Stainless Steel Bolting Materials for High Temperature or High Pressure Service and Other Special Purpose Applications.

<sup>5</sup>Standard Specification for Hex Cap Screws, Bolts and Studs, Steel, Heat Treated, 120/105/90 ksi Minimum Tensile Strength, General Use.

<sup>6</sup>Standard Specification for Carbon and Alloy Steel Externally Threaded Metric Fasteners.

<sup>7</sup>Mechanical properties of fasteners made of carbon steel and alloy steel – Part 1: Bolts, screws and studs

<sup>8</sup>Standard Specification for Stainless Steel Bolts, Hex Cap Screws, and Studs.

<sup>9</sup>Standard Specification for Alloy-Steel and Stainless Steel Bolting for High Temperature or High Pressure Service and Other Special Purpose Applications.

<sup>10</sup> Mechanical properties of fasteners made of corrosion-resistant stainless steel fasteners – Part 1: Bolts, screws and studs

<sup>11</sup>Based on 2-inch (50 mm) gauge length except ASTM A193, which are based on a gauge length of 4d and ISO 898, which is based on 5d; d = nominal diameter.

<sup>12</sup>Nuts of other grades and style having specified proof load stress greater than the specified grade and style are also suitable. Nuts must have specified proof load stresses equal to or greater than the minimum tensile strength of the specified threaded rod. Material types of the nuts and washers must be matched to the threaded rods.

<sup>13</sup>Nuts for metric rods.

<sup>14</sup>Minimum percent reduction of area not reported in the referenced standard.

TABLE 3—SPECIFICATIONS AND PROPERTIES OF COMMON STEEL REINFORCING BARS<sup>1</sup>

REINFORCING SPECIFICATION	UNITS	MINIMUM SPECIFIED ULTIMATE STRENGTH, $f_{uta}$	MINIMUM SPECIFIED YIELD STRENGTH, $f_{ya}$
ASTM A615 <sup>2</sup> , A767 <sup>4</sup> , Grade 80	psi (MPa)	100,000 (690)	80,000 (550)
ASTM A615 <sup>2</sup> , A767 <sup>4</sup> , Grade 75	psi (MPa)	100,000 (690)	75,000 (520)
ASTM A615 <sup>2</sup> , A767 <sup>4</sup> , Grade 60	psi (MPa)	80,000 (550)	60,000 (420)
ASTM A706 <sup>3</sup> , A767 <sup>4</sup> , Grade 60	psi (MPa)	80,000 (550)	60,000 (420)
ASTM A615 <sup>2</sup> , A767 <sup>4</sup> , Grade 40	psi (MPa)	60,000 (420)	40,000 (280)
DIN 488 <sup>5</sup> BSt 500	MPa (psi)	550 (80,000)	500 (72,500)
CAN/CSA G30.18 <sup>6</sup> , Grade 400	MPa (psi)	540 (78,300)	400 (58,000)

For **SI**: 1 psi = 0.006897 MPa. For **pound-inch** units: 1 MPa = 145.0 psi.

<sup>1</sup>Adhesive must be used with specified deformed reinforcing bars. Tabulated values correspond to bar sizes included in this report.

<sup>2</sup>Standard Specification for Deformed and Plain Carbon-Steel Bars for Concrete Reinforcement. Grade 40 and Grade 60 bars furnished to specification are considered ductile elements. In accordance with ACI 318-19 Section 17.10.5.3(a)(vi), deformed reinforcing bars meeting this specification used as ductile steel elements to resist earthquake effects shall be limited to reinforcing bars satisfying the requirements of ACI 318-19 Sections 20.2.2.4 and 20.2.2.5. Grade 75 bars furnished to specification are considered brittle elements unless evidence is otherwise shown to the satisfaction of the registered design professional and code official in accordance with Section 3.2.4.3 of this report.

<sup>3</sup>Standard Specification for Low-Alloy Steel Deformed and Plain Bars for Concrete Reinforcement. Bars furnished to specification are considered ductile elements.

<sup>4</sup>Standard Specification for Zinc-Coated (Galvanized) Steel Bars for Concrete Reinforcement. Bars furnished to specification are considered brittle elements unless evidence is otherwise shown to the satisfaction of the registered design professional and code official in accordance with Section 3.2.4.3 of this report.

<sup>5</sup>Reinforcing steel; reinforcing steel bars; dimensions and masses. Bars furnished to this specification are considered brittle elements unless evidence is otherwise shown to the satisfaction of the registered design professional and code official in accordance with Section 3.2.4.3 of this report.

<sup>6</sup>Billet bars for Concrete Reinforcement.

TABLE 4—STEEL DESIGN INFORMATION FOR FRACTIONAL THREADED ROD

DESIGN INFORMATION		SYMBOL	UNITS	NOMINAL ROD DIAMETER <sup>1</sup> (inch)						
				3/8	1/2	5/8	3/4	7/8	1	1 1/4
Threaded rod nominal outside diameter		<i>d</i>	inch (mm)	0.375 (9.5)	0.500 (12.7)	0.625 (15.9)	0.750 (19.1)	0.875 (22.2)	1.000 (25.4)	1.250 (31.8)
Threaded rod effective cross-sectional area		<i>A<sub>se</sub></i>	inch <sup>2</sup> (mm <sup>2</sup> )	0.0775 (50)	0.1419 (92)	0.2260 (146)	0.3345 (216)	0.4617 (298)	0.6057 (391)	0.9691 (625)
ASTM A36 and ASTM F1554 Grade 36	Nominal strength as governed by steel strength (for a single anchor)	<i>N<sub>sa</sub></i>	lbf (kN)	4,495 (20.0)	8,230 (36.6)	13,110 (58.3)	19,400 (86.3)	26,780 (119.1)	35,130 (156.3)	56,210 (250.0)
		<i>V<sub>sa</sub></i>	lbf (kN)	2,695 (12.0)	4,940 (22.0)	7,860 (35.0)	11,640 (51.8)	16,070 (71.4)	21,080 (93.8)	33,725 (150.0)
	Reduction factor for seismic shear	$\alpha_{V,seis}$	-	0.80						
	Strength reduction factor for tension <sup>2</sup>	$\phi$	-	0.75						
	Strength reduction factor for shear <sup>2</sup>	$\phi$	-	0.65						
ASTM F1554 Grade 55	Nominal strength as governed by steel strength (for a single anchor)	<i>N<sub>sa</sub></i>	lbf (kN)	5,810 (25.9)	10,640 (47.3)	16,950 (75.4)	25,085 (111.6)	34,625 (154.0)	45,425 (202.0)	72,680 (323.3)
		<i>V<sub>sa</sub></i>	lbf (kN)	3,485 (15.5)	6,385 (28.4)	10,170 (45.2)	15,050 (67.0)	20,775 (92.4)	27,255 (121.2)	43,610 (194.0)
	Reduction factor for seismic shear	$\alpha_{V,seis}$	-	0.80						
	Strength reduction factor for tension <sup>2</sup>	$\phi$	-	0.75						
	Strength reduction factor for shear <sup>2</sup>	$\phi$	-	0.65						
ASTM A193 Grade B7 and ASTM F1554 Grade 105	Nominal strength as governed by steel strength (for a single anchor)	<i>N<sub>sa</sub></i>	lbf (kN)	9,685 (43.1)	17,735 (78.9)	28,250 (125.7)	41,810 (186.0)	57,710 (256.7)	75,710 (336.8)	121,135 (538.8)
		<i>V<sub>sa</sub></i>	lbf (kN)	5,815 (25.9)	10,640 (7.3)	16,950 (75.4)	25,085 (111.6)	34,625 (154.0)	45,425 (202.1)	72,680 (323.3)
	Reduction factor for seismic shear	$\alpha_{V,seis}$	-	0.80						
	Strength reduction factor for tension <sup>2</sup>	$\phi$	-	0.75						
	Strength reduction factor for shear <sup>2</sup>	$\phi$	-	0.65						
ASTM A449	Nominal strength as governed by steel strength (for a single anchor)	<i>N<sub>sa</sub></i>	lbf (kN)	9,300 (41.4)	17,025 (75.7)	27,120 (120.6)	40,140 (178.5)	55,905 (248.7)	72,685 (323.3)	101,755 (452.6)
		<i>V<sub>sa</sub></i>	lbf (kN)	5,580 (24.8)	10,215 (45.4)	16,270 (72.4)	24,085 (107.1)	33,540 (149.2)	43,610 (194.0)	61,050 (271.6)
	Reduction factor for seismic shear	$\alpha_{V,seis}$	-	0.80						
	Strength reduction factor for tension <sup>2</sup>	$\phi$	-	0.75						
	Strength reduction factor for shear <sup>2</sup>	$\phi$	-	0.65						
ISO 898-1 Class 5.8	Nominal strength as governed by steel strength (for a single anchor)	<i>N<sub>sa</sub></i>	lbf (kN)	5,620 (25.0)	10,290 (45.8)	16,385 (72.9)	24,250 (107.9)	33,475 (148.9)	43,915 (195.4)	5
		<i>V<sub>sa</sub></i>	lbf (kN)	3,370 (15.0)	6,175 (27.5)	9,830 (43.7)	14,550 (64.7)	20,085 (89.3)	26,350 (117.2)	5
	Reduction factor for seismic shear	$\alpha_{V,seis}$	-	0.80						
	Strength reduction factor for tension <sup>3</sup>	$\phi$	-	0.65						
	Strength reduction factor for shear <sup>3</sup>	$\phi$	-	0.60						
ASTM F593 CW Stainless (Types 304 and 316)	Nominal strength as governed by steel strength (for a single anchor)	<i>N<sub>sa</sub></i>	lbf (kN)	7,750 (34.5)	14,190 (63.1)	22,600 (100.5)	28,430 (126.5)	39,245 (174.6)	51,485 (229.0)	82,370 (366.4)
		<i>V<sub>sa</sub></i>	lbf (kN)	4,650 (20.7)	8,515 (37.9)	13,560 (60.3)	17,060 (75.9)	23,545 (104.7)	30,890 (137.4)	49,425 (219.8)
	Reduction factor for seismic shear	$\alpha_{V,seis}$	-	0.70		0.80				
	Strength reduction factor for tension <sup>3</sup>	$\phi$	-	0.65						
	Strength reduction factor for shear <sup>3</sup>	$\phi$	-	0.60						
ASTM A193 Grade B8/B8M, Class 1 Stainless (Types 304 and 316)	Nominal strength as governed by steel strength (for a single anchor) <sup>4</sup>	<i>N<sub>sa</sub></i>	lbf (kN)	4,420 (19.7)	8,090 (36.0)	12,880 (57.3)	19,065 (84.8)	26,315 (117.1)	34,525 (153.6)	55,240 (245.7)
		<i>V<sub>sa</sub></i>	lbf (kN)	2,650 (11.8)	4,855 (21.6)	7,730 (34.4)	11,440 (50.9)	15,790 (70.2)	20,715 (92.1)	33,145 (147.4)
	Reduction factor for seismic shear	$\alpha_{V,seis}$	-	0.70		0.80				
	Strength reduction factor for tension <sup>2</sup>	$\phi$	-	0.75						
	Strength reduction factor for shear <sup>2</sup>	$\phi$	-	0.65						
ASTM A193 Grade B8/B8M2, Class 2B Stainless (Types 304 and 316)	Nominal strength as governed by steel strength (for a single anchor)	<i>N<sub>sa</sub></i>	lbf (kN)	7,365 (32.8)	13,480 (60.0)	21,470 (95.5)	31,775 (141.3)	43,860 (195.1)	57,545 (256.0)	92,065 (409.5)
		<i>V<sub>sa</sub></i>	lbf (kN)	4,420 (19.7)	8,085 (36.0)	12,880 (57.3)	19,065 (84.8)	26,315 (117.1)	34,525 (153.6)	55,240 (245.7)
	Reduction factor for seismic shear	$\alpha_{V,seis}$	-	0.70		0.80				
	Strength reduction factor for tension <sup>2</sup>	$\phi$	-	0.75						
	Strength reduction factor for shear <sup>2</sup>	$\phi$	-	0.65						

For **SI**: 1 inch = 25.4 mm, 1 lbf = 4.448 N. For **pound-inch** units: 1 mm = 0.03937 inches, 1 N = 0.2248 lbf.

<sup>1</sup>Values provided for steel element material types are based on minimum specified strengths and calculated in accordance with ACI 318-19 Eq. 17.6.1.2 and Eq. 17.7.1.2(b), except where noted. Nuts and washers must be appropriate for the rod. See Table 2 for nut specifications.

<sup>2</sup>The strength reduction factor applies when the load combinations from the IBC or ACI 318-19 are used and the requirements of ACI 318-19 Section 17.5.3 are met. Values correspond to ductile steel elements.

<sup>3</sup>The strength reduction factor applies when the load combinations from the IBC or ACI 318-19 are used and the requirements of ACI 318-19 Section 17.5.3 are met. Values correspond to brittle steel elements.

<sup>4</sup>In accordance with ACI 318-19 Eq. 17.6.1.2 and Eq. 17.7.1.2(b), the calculated values for nominal tension and shear strength for ASTM A193 Grade B8/B8M Class 1 stainless steel threaded rods are based on limiting the specified tensile strength of the anchor steel to 1.9*f<sub>y</sub>* or 57,000 psi (393 MPa).

<sup>5</sup>The referenced standard includes rod diameters up to and including 1-inch (24 mm).

TABLE 5—STEEL DESIGN INFORMATION FOR FRACTIONAL REINFORCING BARS

DESIGN INFORMATION		SYMBOL	UNITS	NOMINAL REINFORCING BAR SIZE (REBAR) <sup>1</sup>										
				#3	#4	#5	#6	#7	#8	#9	#10			
Rebar nominal outside diameter		<i>d</i>	inch (mm)	0.375 (9.5)	0.500 (12.7)	0.625 (15.9)	0.750 (19.1)	0.875 (22.2)	1.000 (25.4)	1.125 (28.7)	1.250 (32.3)			
Rebar effective cross-sectional area		<i>A<sub>se</sub></i>	inch <sup>2</sup> (mm <sup>2</sup> )	0.110 (71.0)	0.200 (129.0)	0.310 (200.0)	0.440 (283.9)	0.600 (387.1)	0.790 (509.7)	1.000 (645.2)	1.270 (819.4)			
ASTM A615 Grade 80	Nominal strength as governed by steel strength (for a single anchor)	<i>N<sub>sa</sub></i>	lbf (kN)	11,000 (48.9)	20,000 (89.0)	31,000 (137.9)	44,000 (195.7)	60,000 (266.9)	79,000 (351.4)	100,000 (444.8)	127,000 (564.9)			
		<i>V<sub>sa</sub></i>	lbf (kN)	6,600 (29.4)	12,000 (53.4)	18,600 (82.7)	26,400 (117.4)	36,000 (160.1)	47,400 (210.8)	60,000 (266.9)	76,200 (338.9)			
	Reduction factor for seismic shear	$\alpha_{V,seis}$	-	0.70			0.80							
	Strength reduction factor for tension <sup>3</sup>	$\phi$	-	0.65										
	Strength reduction factor for shear <sup>3</sup>	$\phi$	-	0.60										
ASTM A615 Grade 75	Nominal strength as governed by steel strength (for a single anchor)	<i>N<sub>sa</sub></i>	lbf (kN)	11,000 (48.9)	20,000 (89.0)	31,000 (137.9)	44,000 (195.7)	60,000 (266.9)	79,000 (351.4)	100,000 (444.8)	127,000 (564.9)			
		<i>V<sub>sa</sub></i>	lbf (kN)	6,600 (29.4)	12,000 (53.4)	18,600 (82.7)	26,400 (117.4)	36,000 (160.1)	47,400 (210.8)	60,000 (266.9)	76,200 (338.9)			
	Reduction factor for seismic shear	$\alpha_{V,seis}$	-	0.70			0.80							
	Strength reduction factor for tension <sup>3</sup>	$\phi$	-	0.65										
	Strength reduction factor for shear <sup>3</sup>	$\phi$	-	0.60										
ASTM A615 Grade 60	Nominal strength as governed by steel strength (for a single anchor)	<i>N<sub>sa</sub></i>	lbf (kN)	8,800 (39.1)	16,000 (71.2)	24,800 (110.3)	35,200 (156.6)	48,000 (213.5)	63,200 (281.1)	80,000 (355.9)	101,600 (452.0)			
		<i>V<sub>sa</sub></i>	lbf (kN)	5,280 (23.5)	9,600 (42.7)	14,880 (66.2)	21,120 (94.0)	28,800 (128.1)	37,920 (168.7)	48,000 (213.5)	60,960 (271.2)			
	Reduction factor for seismic shear	$\alpha_{V,seis}$	-	0.70			0.80							
	Strength reduction factor for tension <sup>3</sup>	$\phi$	-	0.65										
	Strength reduction factor for shear <sup>3</sup>	$\phi$	-	0.60										
ASTM A706 Grade 60	Nominal strength as governed by steel strength (for a single anchor)	<i>N<sub>sa</sub></i>	lbf (kN)	8,800 (39.1)	16,000 (71.2)	24,800 (110.3)	35,200 (156.6)	48,000 (213.5)	63,200 (281.1)	80,000 (355.9)	101,600 (452.0)			
		<i>V<sub>sa</sub></i>	lbf (kN)	5,280 (23.5)	9,600 (42.7)	14,880 (66.2)	21,120 (94.0)	28,800 (128.1)	37,920 (168.7)	48,000 (213.5)	60,960 (271.2)			
	Reduction factor for seismic shear	$\alpha_{V,seis}$	-	0.70			0.80							
	Strength reduction factor for tension <sup>2</sup>	$\phi$	-	0.75										
	Strength reduction factor for shear <sup>2</sup>	$\phi$	-	0.65										
ASTM A615 Grade 40	Nominal strength as governed by steel strength (for a single anchor)	<i>N<sub>sa</sub></i>	Lbf (kN)	6,600 (29.4)	12,000 (53.4)	18,600 (82.7)	26,400 (117.4)	In accordance with ASTM A615, Grade 40 bars are furnished only in sizes No. 3 through No. 6						
		<i>V<sub>sa</sub></i>	Lbf (kN)	3,960 (17.6)	7,200 (32.0)	11,160 (49.6)	15,840 (70.5)							
	Reduction factor for seismic shear	$\alpha_{V,seis}$	-	0.70			0.80							
	Strength reduction factor for tension <sup>3</sup>	$\phi$	-	0.65										
	Strength reduction factor for shear <sup>3</sup>	$\phi$	-	0.60										

For **SI**: 1 inch = 25.4 mm, 1 lbf = 4.448 N. For **pound-inch** units: 1 mm = 0.03937 inches, 1 N = 0.2248 lbf.

<sup>1</sup>Values provided for reinforcing bar material types based on minimum specified strengths and calculated in accordance with ACI 318-19 Eq. 17.6.1.2 and Eq. 17.7.1.2(b).

<sup>2</sup>The strength reduction factor applies when the load combinations from the IBC or ACI 318-19 are used and the requirements of ACI 318-19 Section 17.5.3 are met. Values correspond to ductile steel elements. In accordance with ACI 318-19 Section 17.10.5.3(a)(vi), deformed reinforcing bars meeting this specification used as ductile steel elements to resist earthquake effects shall be limited to reinforcing bars satisfying the requirements of ACI 318-19 Sections 20.2.2.4 and 20.2.2.5.

<sup>3</sup>The strength reduction factor applies when the load combinations from the IBC or ACI 318-19 are used and the requirements of ACI 318-19 Section 17.5.3 are met. Values correspond to brittle steel elements.

TABLE 6—CONCRETE BREAKOUT DESIGN INFORMATION FOR FRACTIONAL THREADED ROD AND REINFORCING BARS<sup>1</sup>

DESIGN INFORMATION	SYMBOL	UNITS	NOMINAL ROD DIAMETER (inch) / REINFORCING BAR SIZE							
			<sup>3</sup> / <sub>8</sub> or #3	<sup>1</sup> / <sub>2</sub> or #4	<sup>5</sup> / <sub>8</sub> or #5	<sup>3</sup> / <sub>4</sub> or #6	<sup>7</sup> / <sub>8</sub> or #7	1 or #8	#9	<sup>1</sup> / <sub>4</sub> or #10
Effectiveness factor for cracked concrete	$k_{c,cr}$	- (SI)	17 (7.1)							
Effectiveness factor for uncracked concrete	$k_{c,uncr}$	- (SI)	24 (10.0)							
Minimum embedment	$h_{ef,min}$	inch (mm)	<sup>2</sup> / <sub>8</sub> (60)	<sup>2</sup> / <sub>4</sub> (70)	<sup>3</sup> / <sub>8</sub> (79)	<sup>3</sup> / <sub>2</sub> (89)	<sup>3</sup> / <sub>2</sub> (89)	4 (102)	<sup>4</sup> / <sub>2</sub> (114)	5 (127)
Maximum embedment	$h_{ef,max}$	inch (mm)	<sup>7</sup> / <sub>2</sub> (191)	10 (254)	<sup>12</sup> / <sub>2</sub> (318)	15 (381)	<sup>17</sup> / <sub>2</sub> (445)	20 (508)	<sup>22</sup> / <sub>2</sub> (572)	25 (635)
Minimum anchor spacing	$s_{min}$	inch (mm)	<sup>1</sup> / <sub>8</sub> (48)	<sup>2</sup> / <sub>2</sub> (64)	<sup>3</sup> / <sub>8</sub> (79)	<sup>3</sup> / <sub>4</sub> (95)	<sup>4</sup> / <sub>8</sub> (111)	5 (127)	<sup>5</sup> / <sub>8</sub> (143)	<sup>6</sup> / <sub>4</sub> (159)
Minimum edge distance	$c_{min}$	inch (mm)	5d where d is nominal outside diameter of the anchor; or see Section 4.1.9 of this report for design with reduced minimum edge distances down to the following values:							
			<sup>1</sup> / <sub>4</sub> (45)						<sup>2</sup> / <sub>4</sub> (70)	
Minimum member thickness	$h_{min}$	inch (mm)	$h_{ef} + 1\frac{1}{4}$ ( $h_{ef} + 30$ )		$h_{ef} + 2d_o$ where $d_o$ is hole diameter; for installation parameters see <a href="#">Table 12</a> of this report					
Critical edge distance—splitting (for uncracked concrete only)	$c_{ac}$	nch (mm)	See Section 4.1.10 of this report							
Strength reduction factor for tension, concrete failure modes, Condition B, (supplemental reinforcement not present) <sup>2</sup> [concrete breakout]	$\phi$	-	0.65							
Strength reduction factor for shear, concrete failure modes, Condition B, (supplemental reinforcement not present) <sup>2</sup> [concrete breakout and pryout]	$\phi$	-	0.70							

For SI: 1 inch = 25.4 mm, 1 lbf = 4.448 N. For pound-inch units: 1 mm = 0.03937 inch, 1 N = 0.2248 lbf.

<sup>1</sup>Additional setting information is described in [Table 12](#) and in the installation instructions, [Figure 4A](#) of this report.

<sup>2</sup>Condition A requires supplemental reinforcement, while Condition B applies where supplemental reinforcement is not provided or where pryout governs, as set forth in ACI 318-19 Section 17.5.3. The strength reduction factor applies when the load combinations from the IBC or ACI 318-19 are used and the requirements of ACI 318-19 Section 17.5.3 are met.

TABLE 7—BOND STRENGTH DESIGN INFORMATION FOR FRACTIONAL THREADED RODS AND REINFORCING BARS<sup>1</sup>

DESIGN INFORMATION		SYMBOL	UNITS	NOMINAL ROD DIAMETER (inch)							
				3/8	1/2	5/8	3/4	7/8	1	1 1/4	
Minimum embedment		$h_{ef,min}$	inch (mm)	2 3/8 (60)	2 3/4 (70)	3 1/8 (79)	3 1/2 (89)	3 1/2 (89)	4 (102)	5 (127)	
Maximum embedment		$h_{ef,max}$	inch (mm)	7 1/2 (191)	10 (254)	12 1/2 (318)	15 (381)	17 1/2 (445)	20 (508)	25 (635)	
<b>110°F (43°C) Maximum long-term service temperature; 140°F (60°C) maximum short-term service temperature<sup>3,5</sup> with Threaded Rods</b>	Characteristic bond strength in cracked concrete <sup>6,9</sup>	$\tau_{k,cr}$	psi (N/mm <sup>2</sup> )	1,206 (8.3)	1,206 (8.3)	1,206 (8.3)	1,206 (8.3)	1,206 (8.3)	1,206 (8.3)	1,206 (8.3)	
	Characteristic bond strength in cracked concrete, short-term loading only <sup>9</sup>		psi (N/mm <sup>2</sup> )	1,206 (8.3)	1,206 (8.3)	1,206 (8.3)	1,206 (8.3)	1,206 (8.3)	1,206 (8.3)	1,206 (8.3)	
	Characteristic bond strength in uncracked concrete <sup>6,8</sup>	$\tau_{k,uncr}$	psi (N/mm <sup>2</sup> )	1,829 (12.6)	1,738 (12.0)	1,671 (11.5)	1,617 (11.1)	1,567 (10.8)	1,538 (10.6)	1,479 (10.2)	
	Characteristic bond strength in uncracked concrete, short-term loading only <sup>8</sup>		psi (N/mm <sup>2</sup> )	1,829 (12.6)	1,738 (12.0)	1,671 (11.5)	1,617 (11.1)	1,567 (10.8)	1,538 (10.6)	1,479 (10.2)	
<b>110°F (43°C) Maximum long-term service temperature; 176°F (80°C) maximum short-term service temperature<sup>4,5</sup> with Threaded Rods</b>	Characteristic bond strength in cracked concrete <sup>6,9</sup>	$\tau_{k,cr}$	psi (N/mm <sup>2</sup> )	882 (6.1)	882 (6.1)	882 (6.1)	882 (6.1)	882 (6.1)	882 (6.1)	882 (6.1)	
	Characteristic bond strength in cracked concrete, short-term loading only <sup>9</sup>		psi (N/mm <sup>2</sup> )	882 (6.1)	882 (6.1)	882 (6.1)	882 (6.1)	882 (6.1)	882 (6.1)	882 (6.1)	
	Characteristic bond strength in uncracked concrete <sup>6,8</sup>	$\tau_{k,uncr}$	psi (N/mm <sup>2</sup> )	1,334 (9.2)	1,262 (8.7)	1,218 (8.4)	1,175 (8.1)	1,146 (7.9)	1,117 (7.7)	1,073 (7.4)	
	Characteristic bond strength in uncracked concrete, short-term loading only <sup>8</sup>		psi (N/mm <sup>2</sup> )	1,334 (9.2)	1,262 (8.7)	1,218 (8.4)	1,175 (8.1)	1,146 (7.9)	1,117 (7.7)	1,073 (7.4)	
DESIGN INFORMATION		SYMBOL	UNITS	NOMINAL REINFORCING BAR SIZE							
				#3	#4	#5	#6	#7	#8	#9	#10
Minimum embedment		$h_{ef,min}$	inch (mm)	2 3/8 (60)	2 3/4 (70)	3 1/8 (79)	3 1/2 (89)	3 1/2 (89)	4 (102)	4 1/2 (114)	5 (127)
Maximum embedment		$h_{ef,max}$	inch (mm)	7 1/2 (191)	10 (254)	12 1/2 (318)	15 (381)	17 1/2 (445)	20 (508)	22 1/2 (572)	25 (635)
<b>110°F (43°C) Maximum long-term service temperature; 140°F (60°C) maximum short-term service temperature<sup>3,5</sup> with Rebars</b>	Characteristic bond strength in cracked concrete <sup>6,9</sup>	$\tau_{k,cr}$	psi (N/mm <sup>2</sup> )	1,206 (8.3)	1,170 (8.1)	1,122 (7.7)	1,122 (7.7)	1,122 (7.7)	1,122 (7.7)	1,122 (7.7)	1,122 (7.7)
	Characteristic bond strength in cracked concrete, short-term loading only <sup>9</sup>		psi (N/mm <sup>2</sup> )	1,206 (8.3)	1,170 (8.1)	1,122 (7.7)	1,122 (7.7)	1,122 (7.7)	1,122 (7.7)	1,122 (7.7)	1,122 (7.7)
	Characteristic bond strength in uncracked concrete <sup>6,8</sup>	$\tau_{k,uncr}$	psi (N/mm <sup>2</sup> )	1,829 (12.6)	1,738 (12.0)	1,671 (11.5)	1,617 (11.1)	1,567 (10.8)	1,538 (10.6)	1,507 (10.4)	1,479 (10.2)
	Characteristic bond strength in uncracked concrete, short-term loading only <sup>8</sup>		psi (N/mm <sup>2</sup> )	1,829 (12.6)	1,738 (12.0)	1,671 (11.5)	1,617 (11.1)	1,567 (10.8)	1,538 (10.6)	1,507 (10.4)	1,479 (10.2)
<b>110°F (43°C) Maximum long-term service temperature; 176°F (80°C) maximum short-term service temperature<sup>4,5</sup> with Rebars</b>	Characteristic bond strength in cracked concrete <sup>6,9</sup>	$\tau_{k,cr}$	psi (N/mm <sup>2</sup> )	882 (6.1)	848 (5.8)	814 (5.6)	814 (5.6)	814 (5.6)	814 (5.6)	814 (5.6)	814 (5.6)
	Characteristic bond strength in cracked concrete, short-term loading only <sup>9</sup>		psi (N/mm <sup>2</sup> )	882 (6.1)	848 (5.8)	814 (5.6)	814 (5.6)	814 (5.6)	814 (5.6)	814 (5.6)	814 (5.6)
	Characteristic bond strength in uncracked concrete <sup>6,8</sup>	$\tau_{k,uncr}$	psi (N/mm <sup>2</sup> )	1,334 (9.2)	1,262 (8.7)	1,218 (8.4)	1,175 (8.1)	1,146 (7.9)	1,117 (7.7)	1,102 (7.6)	1,073 (7.4)
	Characteristic bond strength in uncracked concrete, short-term loading only <sup>8</sup>		psi (N/mm <sup>2</sup> )	1,334 (9.2)	1,262 (8.7)	1,218 (8.4)	1,175 (8.1)	1,146 (7.9)	1,117 (7.7)	1,102 (7.6)	1,073 (7.4)
Permissible installation conditions <sup>7</sup>	Dry concrete	Anchor Category	1								
		$\phi_d$	0.65								
	Water-saturated concrete, Water-filled hole (flooded)	Anchor Category	2								
		$\phi_{ws}, \phi_{wf}$	0.55								
Underwater (submerged)	Anchor Category	2			3						
	$\phi_{uw}$	0.55			0.45						
Reduction factor for seismic tension <sup>9</sup>		$\alpha_{N,seis}$	1.0								

For **SI**: 1 inch = 25.4 mm, 1 psi = 0.006894 MPa. For **pound-inch** units: 1 mm = 0.03937 inch, 1 MPa = 145.0 psi.

<sup>1</sup>Bond strength values correspond to a normal-weight concrete compressive strength  $f'_c = 2,500$  psi (17.2 MPa). For concrete compressive strength,  $f'_c$  between 2,500 psi and 8,000 psi (17.2 MPa and 55.2 MPa), the tabulated characteristic bond strength may be increased by a factor of  $(f'_c / 2,500)^{0.23}$  [For **SI**:  $(f'_c / 17.2)^{0.23}$ ]. See Section 4.1.4 of this report for bond strength determination.

<sup>2</sup>The modification factor for bond strength of adhesive anchors in lightweight concrete shall be taken as given in ACI 318-19 Section 17.2.4, where applicable.

<sup>3</sup>The maximum short-term service temperature may be increased to 162°F (72°C) provided characteristic bond strengths are reduced by 3 percent. Long-term and short-term temperatures meet the requirements of Section 8.5 of ACI 355.4 and Table 8.1, Temperature Category B.

<sup>4</sup>Long-term and short-term temperatures meet the requirements of Section 8.5 of ACI 355.4 and Table 8.1, Temperature Category A.

<sup>5</sup>Short-term base material service temperatures are those that occur over brief intervals, e.g. as a result of diurnal cycling. Long-term base material service temperatures are roughly constant over significant periods of time.

<sup>6</sup>Characteristic bond strengths are for sustained loads including dead and live loads.

<sup>7</sup>Permissible installation conditions include dry concrete, water-saturated concrete, water-filled holes and underwater. Water-filled holes include applications in dry or water-saturated concrete where the drilled holes contain standing water during anchor installation. For installation instructions see [Figure 4A](#) of this report.

<sup>8</sup>Bond strength values for uncracked concrete are applicable for structures assigned to Seismic Design Categories A and B only.

<sup>9</sup>For structures assigned to Seismic Design Categories C, D, E or F, the tabulated bond strength values for cracked concrete do not require an additional reduction factor applied for seismic tension ( $\alpha_{N,seis} = 1.0$ ), where seismic design is applicable. See Section 4.1.11 of this report for requirements for seismic design.

TABLE 8—STEEL DESIGN INFORMATION FOR METRIC THREADED RODS

DESIGN INFORMATION		SYMBOL	UNITS	NOMINAL ROD DIAMETER <sup>1</sup> (mm)						
				10	12	16	20	24	27	30
Threaded rod nominal outside diameter		$d$	mm (inch)	10 (0.39)	12 (0.47)	16 (0.63)	20 (0.79)	24 (0.94)	27 (1.06)	30 (1.18)
Threaded rod effective cross-sectional area		$A_{se}$	mm <sup>2</sup> (inch <sup>2</sup> )	58.0 (0.090)	84.3 (0.131)	157 (0.243)	245 (0.380)	353 (0.547)	459 (0.711)	561 (0.870)
ISO 898-1 Class 5.8	Nominal strength as governed by steel strength (for a single anchor)	$N_{sa}$	kN (lbf)	29.0 (6,520)	42.0 (9,475)	78.5 (17,645)	122.5 (27,540)	176.5 (39,680)	229.5 (51,595)	280.5 (63,060)
		$V_{sa}$	kN (lbf)	17.4 (3,910)	25.5 (5,685)	47.0 (10,590)	73.5 (16,525)	106.0 (23,805)	137.5 (30,956)	168.5 (37,835)
	Reduction factor for seismic shear	$\alpha_{V,seis}$	-	0.80						
	Strength reduction factor for tension <sup>3</sup>	$\phi$	-	0.65						
	Strength reduction factor for shear <sup>3</sup>	$\phi$	-	0.60						
ISO 898-1 Class 8.8	Nominal strength as governed by steel strength (for a single anchor)	$N_{sa}$	kN (lbf)	46.5 (10,430)	67.5 (15,160)	125.5 (28,235)	196.0 (44,065)	282.5 (63,485)	367.0 (82,550)	449.0 (100,895)
		$V_{sa}$	kN (lbf)	27.9 (6,270)	40.5 (9,095)	75.5 (16,940)	117.5 (26,440)	169.5 (38,090)	220.5 (49,530)	269.5 (60,535)
	Reduction factor for seismic shear	$\alpha_{V,seis}$	-	0.80						
	Strength reduction factor for tension <sup>3</sup>	$\phi$	-	0.65						
	Strength reduction factor for shear <sup>3</sup>	$\phi$	-	0.60						
ISO 3506-1 Stainless Grades A4 and HCR	Nominal strength as governed by steel strength (for a single anchor)	$N_{sa}$	kN (lbf)	40.6 (9,125)	59.0 (13,265)	109.9 (24,705)	171.5 (38,555)	247.1 (55,550)	229.5 (51,595)	280.5 (63,060)
		$V_{sa}$	kN (lbf)	24.4 (5,475)	35.4 (7,960)	65.9 (14,825)	102.9 (23,135)	148.3 (33,330)	137.7 (30,955)	168.3 (37,835)
	Reduction factor for seismic shear	$\alpha_{V,seis}$	-	0.80						
	Strength reduction factor for tension <sup>3</sup>	$\phi$	-	0.65						
	Strength reduction factor for shear <sup>3</sup>	$\phi$	-	0.60						
ASTM A193M Grade B8/B8M, Class 1 Stainless (Types 304 and 316)	Nominal strength as governed by steel strength (for a single anchor) <sup>4</sup>	$N_{sa}$	kN (lbf)	22.8 (5,125)	33.1 (7,450)	61.7 (13,870)	96.3 (21,645)	138.7 (31,045)	180.4 (40,455)	220.5 (49,465)
		$V_{sa}$	kN (lbf)	13.7 (3,075)	19.9 (4,470)	37.0 (8,325)	57.8 (12,990)	83.2 (18,715)	108.2 (24,335)	132.3 (29,740)
	Reduction factor for seismic shear	$\alpha_{V,seis}$	-	0.80						
	Strength reduction factor for tension <sup>2</sup>	$\phi$	-	0.75						
	Strength reduction factor for shear <sup>2</sup>	$\phi$	-	0.65						
ASTM A193M Grade B8/B8M2, Class 2B Stainless (Types 304 and 316)	Nominal strength as governed by steel strength (for a single anchor)	$N_{sa}$	kN (lbf)	38.0 (8,540)	55.2 (12,415)	102.8 (23,120)	160.5 (36,080)	231.2 (51,980)	300.6 (67,590)	367.5 (82,610)
		$V_{sa}$	kN (lbf)	22.8 (5,125)	33.1 (7,450)	61.7 (13,870)	96.3 (21,645)	138.7 (31,045)	180.4 (40,455)	220.5 (49,465)
	Reduction factor for seismic shear	$\alpha_{V,seis}$	-	0.80						
	Strength reduction factor for tension <sup>2</sup>	$\phi$	-	0.75						
	Strength reduction factor for shear <sup>2</sup>	$\phi$	-	0.65						

For **pound-inch** units: 1 mm = 0.03937 inches, 1 N = 0.2248 lbf. For **SI**: 1 inch = 25.4 mm, 1 lbf = 4.448 N.

<sup>1</sup>Values provided for steel element material types are based on minimum specified strengths and calculated in accordance with ACI 318-19 Eq. 17.6.1.2 and Eq. 17.7.1.2(b) except where noted. Nuts and washers must be appropriate for the rod. See [Table 2](#) for nut specifications.

<sup>2</sup>The strength reduction factor applies when the load combinations from the IBC or ACI 318-19 are used and the requirements of ACI 318-19 Section 17.5.3 are met. Values correspond to ductile steel elements.

<sup>3</sup>The strength reduction factor applies when the load combinations from the IBC or ACI 318-19 are used and the requirements of ACI 318-19 Section 17.5.3 are met. Values correspond to brittle steel elements.

<sup>4</sup>In accordance with ACI 318-19 Eq. 17.6.1.2 and Eq. 17.7.1.2(b), the calculated values for nominal tension and shear strength for ASTM A193 Grade B8/B8M Class 1 stainless steel threaded rods are based on limiting the specified tensile strength of the anchor steel to 1.9 $f_y$  or 393 MPa (57,000 psi).

TABLE 9—STEEL DESIGN INFORMATION FOR METRIC REINFORCING BARS<sup>1</sup>

DESIGN INFORMATION		SYMBOL	UNITS	NOMINAL REINFORCING BAR SIZE (Ø)							
				Ø10	Ø12	Ø14	Ø16	Ø20	Ø25	Ø28	Ø32
Rebar nominal outside diameter		<i>d</i>	mm (inch)	10.0 (0.394)	12.0 (0.472)	14.0 (0.551)	16.0 (0.630)	20.0 (0.787)	25.0 (0.984)	28.0 (1.102)	32.0 (1.260)
Rebar effective cross-sectional area		<i>A<sub>se</sub></i>	mm <sup>2</sup> (inch <sup>2</sup> )	78.5 (0.122)	113.1 (0.175)	153.9 (0.239)	201.1 (0.312)	314.2 (0.487)	490.9 (0.761)	615.8 (0.954)	804.2 (1.247)
DIN 488 BSt 500	Nominal strength as governed by steel strength (for a single anchor)	<i>N<sub>sa</sub></i>	kN (lbf)	43.0 (9,710)	62.0 (13,985)	84.5 (19,035)	110.5 (24,860)	173.0 (38,845)	270.0 (60,695)	338.5 (76,135)	442.5 (99,440)
		<i>V<sub>sa</sub></i>	kN (lbf)	26.0 (5,825)	37.5 (8,390)	51.0 (11,420)	66.5 (14,915)	103.0 (23,305)	162.0 (36,415)	203.0 (45,680)	265.5 (59,665)
	Reduction factor for seismic shear	<i>α<sub>V,seis</sub></i>	-	0.70			0.80				
	Strength reduction factor for tension <sup>2</sup>	<i>φ</i>	-	0.65							
	Strength reduction factor for shear <sup>2</sup>	<i>φ</i>	-	0.60							

For **pound-inch** units: 1 mm = 0.03937 inches, 1 N = 0.2248 lbf. For **SI**: 1 inch = 25.4 mm, 1 lbf = 4.448 N.

<sup>1</sup>Values provided for reinforcing bar material types based on minimum specified strengths and calculated in accordance with ACI 318-19 Eq. 17.6.1.2 and Eq. 17.7.1.2(b).

<sup>2</sup>The strength reduction factor applies when the load combinations from the IBC or ACI 318-19 are used and the requirements of ACI 318-19 Section 17.5.3 are met. Values correspond to brittle steel elements.

TABLE 10—CONCRETE BREAKOUT DESIGN INFORMATION FOR METRIC THREADED ROD AND REINFORCING BARS<sup>1</sup>

DESIGN INFORMATION	SYMBOL	UNITS	NOMINAL ROD DIAMETER / REINFORCING BAR SIZE											
			M10 or Ø10	M12	Ø12	Ø14	M16 or Ø16	M20 or Ø20	M24	Ø25	M27	Ø28	M30	Ø32
Effectiveness factor for cracked concrete	<i>k<sub>c,cr</sub></i>	SI -	17 (7.1)											
Effectiveness factor for uncracked concrete	<i>k<sub>c,uncr</sub></i>	SI -	24 (10.0)											
Minimum embedment	<i>h<sub>ef,min</sub></i>	mm (inch)	60 (2.4)	70 (2.8)	70 (2.8)	70 (2.8)	80 (3.2)	90 (3.6)	96 (3.8)	100 (3.9)	108 (4.3)	112 (4.4)	120 (4.7)	128 (5.0)
Maximum embedment	<i>h<sub>ef,max</sub></i>	mm (inch)	200 (7.8)	240 (14.8)	240 (14.8)	280 (11.0)	320 (12.6)	400 (15.8)	480 (18.8)	500 (19.6)	540 (21.4)	560 (22.0)	600 (23.6)	640 (25.2)
Minimum anchor spacing	<i>s<sub>min</sub></i>	mm (inch)	50 (2.0)	60 (2.4)	60 (2.4)	70 (3.7)	80 (3.2)	100 (4.0)	120 (4.8)	125 (4.9)	135 (5.3)	140 (5.5)	150 (5.9)	160 (6.3)
Minimum edge distance	<i>c<sub>min</sub></i>	mm (inch)	5 <i>d</i> where <i>d</i> is nominal outside diameter of the anchor; or see Section 4.1.9 of this report for design with reduced minimum edge distances down to the following values:											
			45 (1.75)						70 (2.75)					
Minimum member thickness	<i>h<sub>min</sub></i>	mm (inch)	<i>h<sub>ef</sub></i> + 30 ( <i>h<sub>ef</sub></i> + 1 <sup>1</sup> / <sub>4</sub> )			<i>h<sub>ef</sub></i> + 2 <i>d<sub>o</sub></i> where <i>d<sub>o</sub></i> is hole diameter; for installation parameters see Table 12 of this report								
Critical edge distance—splitting (for uncracked concrete only)	<i>c<sub>ac</sub></i>	mm (inch)	See Section 4.1.10 of this report											
Strength reduction factor for tension, concrete failure modes, Condition B, (supplemental reinforcement not present) <sup>2</sup> [concrete breakout]	<i>φ</i>	-	0.65											
Strength reduction factor for shear, concrete failure modes, Condition B, (supplemental reinforcement not present) <sup>2</sup> [concrete breakout and pryout]	<i>φ</i>	-	0.70											

For **pound-inch** units: 1 mm = 0.03937 inch, 1 N = 0.2248 lbf. For **SI**: 1 inch = 25.4 mm, 1 lbf = 4.448 N.

<sup>1</sup>Additional setting information is described in Table 12 and the installation instructions, Figure 4A of this report.

<sup>2</sup>Condition A requires supplemental reinforcement, while Condition B applies where supplemental reinforcement is not provided or where pryout governs, as set forth in ACI 318-19 Section 17.5.3. The strength reduction factor applies when the load combinations from the IBC or ACI 318-19 are used and the requirements of ACI 318-19 Section 17.5.3 are met.

TABLE 11—BOND STRENGTH DESIGN INFORMATION FOR METRIC THREADED RODS AND REINFORCING BARS<sup>1</sup>

DESIGN INFORMATION		SYMBOL	UNITS	NOMINAL ROD DIAMETER							
				M10	M12	M16	M20	M24	M27	M30	
Minimum embedment		$h_{ef,min}$	mm (inch)	60 (2.4)	70 (2.8)	80 (3.2)	90 (3.6)	96 (3.8)	108 (4.3)	120 (4.7)	
Maximum embedment		$h_{ef,max}$	mm (inch)	200 (7.8)	240 (14.8)	320 (12.6)	400 (15.8)	480 (18.8)	540 (21.4)	600 (23.6)	
<b>110°F (43°C)</b> Maximum long-term service temperature; <b>140°F (60°C)</b> maximum short-term service temperature <sup>3,5</sup> with <b>Threaded Rods</b>	Characteristic bond strength in cracked concrete <sup>6,9</sup>	$\tau_{k,cr}$	N/mm <sup>2</sup> (psi)	8.3 (1205)	8.3 (1205)	8.3 (1205)	8.3 (1205)	8.3 (1205)	8.3 (1205)	8.3 (1205)	
	Characteristic bond strength in cracked concrete, short-term loading only <sup>9</sup>		N/mm <sup>2</sup> (psi)	8.3 (1205)	8.3 (1205)	8.3 (1205)	8.3 (1205)	8.3 (1205)	8.3 (1205)	8.3 (1205)	
	Characteristic bond strength in uncracked concrete <sup>6,8</sup>	$\tau_{k,uncr}$	N/mm <sup>2</sup> (psi)	12.5 (1813)	12.1 (1755)	11.5 (1668)	11.1 (1610)	10.7 (1552)	10.5 (1523)	10.3 (1494)	
	Characteristic bond strength in uncracked concrete, short-term loading only <sup>8</sup>		N/mm <sup>2</sup> (psi)	12.5 (1813)	12.1 (1755)	11.5 (1668)	11.1 (1610)	10.7 (1552)	10.5 (1523)	10.3 (1494)	
<b>110°F (43°C)</b> Maximum long-term service temperature; <b>176°F (80°C)</b> maximum short-term service temperature <sup>4,5</sup> with <b>Threaded Rods</b>	Characteristic bond strength in cracked concrete <sup>6,9</sup>	$\tau_{k,cr}$	N/mm <sup>2</sup> (psi)	6.1 (882)	6.1 (882)	6.1 (882)	6.1 (882)	6.1 (882)	6.1 (882)	6.1 (882)	
	Characteristic bond strength in cracked concrete, short-term loading only <sup>9</sup>		N/mm <sup>2</sup> (psi)	6.1 (882)	6.1 (882)	6.1 (882)	6.1 (882)	6.1 (882)	6.1 (882)	6.1 (882)	
	Characteristic bond strength in uncracked concrete <sup>6,8</sup>	$\tau_{k,uncr}$	N/mm <sup>2</sup> (psi)	9.1 (1320)	8.8 (1276)	8.4 (1218)	8.1 (1175)	7.8 (1131)	7.7 (1117)	7.5 (1088)	
	Characteristic bond strength in uncracked concrete, short-term loading only <sup>8</sup>		N/mm <sup>2</sup> (psi)	9.1 (1320)	8.8 (1276)	8.4 (1218)	8.1 (1175)	7.8 (1131)	7.7 (1117)	7.5 (1088)	
DESIGN INFORMATION		SYMBOL	UNITS	REINFORCING BAR SIZE							
Minimum embedment		$h_{ef,min}$	mm (inch)	60 (2.4)	70 (2.8)	70 (2.8)	80 (3.2)	90 (3.6)	100 (3.9)	112 (4.4)	128 (5.0)
Maximum embedment		$h_{ef,max}$	mm (inch)	200 (7.8)	240 (14.8)	280 (11.0)	320 (12.6)	400 (15.8)	500 (19.6)	560 (22.0)	640 (25.2)
<b>110°F (43°C)</b> Maximum long-term service temperature; <b>140°F (60°C)</b> maximum short-term service temperature <sup>3,5</sup> with <b>Rebars</b>	Characteristic bond strength in cracked concrete <sup>6,9</sup>	$\tau_{k,cr}$	N/mm <sup>2</sup> (psi)	8.3 (1205)	8.1 (1171)	7.7 (1120)	7.7 (1120)	7.7 (1120)	7.7 (1120)	7.7 (1120)	7.7 (1120)
	Characteristic bond strength in cracked concrete, short-term loading only <sup>9</sup>		N/mm <sup>2</sup> (psi)	8.3 (1205)	8.1 (1171)	7.7 (1120)	7.7 (1120)	7.7 (1120)	7.7 (1120)	7.7 (1120)	7.7 (1120)
	Characteristic bond strength in uncracked concrete <sup>6,8</sup>	$\tau_{k,uncr}$	N/mm <sup>2</sup> (psi)	12.5 (1813)	12.1 (1755)	11.8 (1711)	11.5 (1668)	11.1 (1610)	10.6 (1537)	10.4 (1508)	10.2 (1479)
	Characteristic bond strength in uncracked concrete, short-term loading only <sup>8</sup>		N/mm <sup>2</sup> (psi)	12.5 (1813)	12.1 (1755)	11.8 (1711)	11.5 (1668)	11.1 (1610)	10.6 (1537)	10.4 (1508)	10.2 (1479)
<b>110°F (43°C)</b> Maximum long-term service temperature; <b>176°F (80°C)</b> maximum short-term service temperature <sup>4,5</sup> with <b>Rebars</b>	Characteristic bond strength in cracked concrete <sup>6,9</sup>	$\tau_{k,cr}$	N/mm <sup>2</sup> (psi)	6.1 (882)	5.9 (848)	5.6 (814)	5.6 (814)	5.6 (814)	5.6 (814)	5.6 (814)	5.6 (814)
	Characteristic bond strength in cracked concrete, short-term loading only <sup>9</sup>		N/mm <sup>2</sup> (psi)	6.1 (882)	5.9 (848)	5.6 (814)	5.6 (814)	5.6 (814)	5.6 (814)	5.6 (814)	5.6 (814)
	Characteristic bond strength in uncracked concrete <sup>6,8</sup>	$\tau_{k,uncr}$	N/mm <sup>2</sup> (psi)	9.1 (1320)	8.8 (1276)	8.6 (1247)	8.4 (1218)	8.1 (1175)	7.8 (1131)	7.6 (1102)	7.4 (1073)
	Characteristic bond strength in uncracked concrete, short-term loading only <sup>8</sup>		N/mm <sup>2</sup> (psi)	9.1 (1320)	8.8 (1276)	8.6 (1247)	8.4 (1218)	8.1 (1175)	7.8 (1131)	7.6 (1102)	7.4 (1073)
Permissible installation conditions <sup>7</sup>	Dry concrete	Anchor Category	1								
		$\phi_d$	0.65								
	Water-saturated concrete, Water-filled hole (flooded)	Anchor Category	2								
		$\phi_{ws}, \phi_{wf}$	0.55								
Underwater (submerged)	Anchor Category	2				3					
	$\phi_{uw}$	0.55				0.45					
Reduction factor for seismic tension		$\alpha_{N,seis}$	1.0								

For **pound-inch** units: 1 mm = 0.03937 inch, 1 MPa = 145.0 psi. For **SI**: 1 inch = 25.4 mm, 1 psi = 0.006894 MPa.

<sup>1</sup>Bond strength values correspond to normal-weight concrete compressive strength  $f'_c = 2,500$  psi (17.2 MPa). For concrete compressive strength,  $f'_c$  between 2,500 psi and 8,000 psi (17.2 MPa and 55.2 MPa), the tabulated characteristic bond strength may be increased by a factor of  $(f'_c / 2,500)^{0.23}$  [For **SI**:  $(f'_c / 17.2)^{0.23}$ ]. See Section 4.1.8 of this report for bond strength determination.

<sup>2</sup>The modification factor for bond strength of adhesive anchors in lightweight concrete shall be taken as given in ACI 318-19 17.2.4.

<sup>3</sup>The maximum short-term service temperature may be increased to 162°F (72°C) provided characteristic bond strengths are reduced by 3 percent. Long-term and short-term temperatures meet the requirements of Section 8.5 of ACI 355.4 and Table 8.1, Temperature Category B.

<sup>4</sup>Long-term and short-term temperatures meet the requirements of Section 8.5 of ACI 355.4 and Table 8.1, Temperature Category A.

<sup>5</sup>Short-term elevated concrete temperatures are those that occur over brief intervals, e.g. as a result of diurnal cycling. Long-term concrete temperatures are roughly constant over significant periods of time.

<sup>6</sup>Characteristic bond strengths are for sustained loads including dead and live loads.

<sup>7</sup>Permissible installation conditions include dry concrete, water-saturated concrete, water-filled holes and underwater. Water-filled holes include applications in dry or water-saturated concrete where the drilled holes contain standing water during anchor installation. For installation instructions see [Figure 4A](#) of this report.

<sup>8</sup>Bond strength values for uncracked concrete are applicable for structures assigned to Seismic Design Categories A and B only.

<sup>9</sup>For structures assigned to Seismic Design Categories C, D, E or F, the tabulated bond strength values for cracked concrete do not require an additional reduction factor applied for seismic tension ( $\alpha_{N,seis} = 1.0$ ), where seismic design is applicable. See Section 4.1.11 of this report for requirements for seismic design.

TABLE 12—INSTALLATION PARAMETERS FOR THREADED RODS AND REINFORCING BARS FOR POST-INSTALLED ADHESIVE ANCHORS<sup>7</sup>

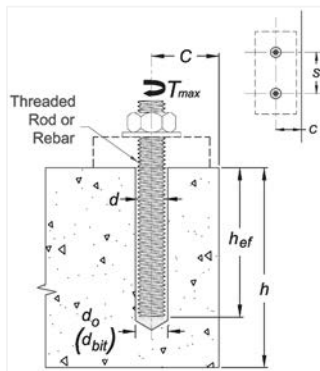

PARAMETER	SYMBOL	UNITS	FRACTIONAL NOMINAL ROD DIAMETER (inch) / REINFORCING BAR SIZE										
			<sup>3</sup> / <sub>8</sub> or #3	<sup>1</sup> / <sub>2</sub>	#4	<sup>5</sup> / <sub>8</sub> or #5	<sup>3</sup> / <sub>4</sub> or #6	<sup>7</sup> / <sub>8</sub> or #7	1 or #8	#9	<sup>1</sup> / <sub>4</sub>	#10	
Threaded rod outside diameter	<i>d</i>	inch (mm)	0.375 (9.5)	0.500 (12.7)	0.625 (15.9)	0.750 (19.1)	0.875 (22.2)	1.000 (25.4)	-	1.250 (31.8)	-		
Rebar nominal outside diameter	<i>d</i>	inch (mm)	0.375 (9.5)	0.500 (12.7)	0.625 (15.9)	0.750 (19.1)	0.875 (22.2)	1.000 (25.4)	1.125 (28.7)	-	1.250 (31.8)		
Carbide drill bit nominal size <sup>6</sup>	<i>d</i> <sub>bit</sub> ( <i>d</i> <sub>o</sub> )	inch	<sup>7</sup> / <sub>16</sub>	<sup>9</sup> / <sub>16</sub>	<sup>5</sup> / <sub>8</sub>	<sup>11</sup> / <sub>16</sub> or <sup>3</sup> / <sub>4</sub> <sup>5</sup>	<sup>7</sup> / <sub>8</sub>	1	<sup>1</sup> / <sub>8</sub>	<sup>13</sup> / <sub>8</sub>	<sup>13</sup> / <sub>8</sub>	<sup>1</sup> / <sub>2</sub>	
Minimum embedment	<i>h</i> <sub>ef,min</sub>	inch (mm)	<sup>23</sup> / <sub>8</sub> (60)	<sup>23</sup> / <sub>4</sub> (70)	<sup>31</sup> / <sub>8</sub> (79)	<sup>31</sup> / <sub>2</sub> (89)	<sup>31</sup> / <sub>2</sub> (89)	4 (102)	<sup>41</sup> / <sub>2</sub> (114)	5 (127)	5 (127)		
Maximum embedment	<i>h</i> <sub>ef,max</sub>	inch (mm)	<sup>71</sup> / <sub>2</sub> (191)	10 (254)	<sup>121</sup> / <sub>2</sub> (318)	15 (381)	<sup>171</sup> / <sub>2</sub> (445)	20 (508)	<sup>221</sup> / <sub>2</sub> (572)	25 (635)	25 (635)		
Minimum member thickness	<i>h</i> <sub>min</sub>	inch (mm)	<i>h</i> <sub>ef</sub> + <sup>1</sup> / <sub>4</sub> ( <i>h</i> <sub>ef</sub> + 30)			<i>h</i> <sub>ef</sub> + 2 <i>d</i> <sub>o</sub>							
Minimum anchor spacing	<i>S</i> <sub>min</sub>	inch (mm)	<sup>17</sup> / <sub>8</sub> (48)	<sup>21</sup> / <sub>2</sub> (64)	<sup>31</sup> / <sub>8</sub> (79)	<sup>33</sup> / <sub>4</sub> (95)	<sup>43</sup> / <sub>8</sub> (111)	5 (127)	<sup>55</sup> / <sub>8</sub> (143)	<sup>61</sup> / <sub>4</sub> (159)	<sup>61</sup> / <sub>4</sub> (159)		
Minimum edge distance	<i>C</i> <sub>min</sub>	inch (mm)	<sup>17</sup> / <sub>8</sub> (48)	<sup>21</sup> / <sub>2</sub> (64)	<sup>31</sup> / <sub>8</sub> (79)	<sup>33</sup> / <sub>4</sub> (95)	<sup>43</sup> / <sub>8</sub> (111)	5 (127)	<sup>55</sup> / <sub>8</sub> (143)	<sup>61</sup> / <sub>4</sub> (159)	<sup>61</sup> / <sub>4</sub> (159)		
Max. torque <sup>1</sup>	<i>T</i> <sub>max</sub>	ft-lbs	15	30	60	105	125	165	200	280	280		
Max. torque <sup>1,2</sup> (low strength rods)	<i>T</i> <sub>max</sub>	ft-lbs	5	20	40	60	100	165	-	280	-		
Minimum edge distance, reduced <sup>4</sup>	<i>C</i> <sub>min,red</sub>	inch (mm)	<sup>13</sup> / <sub>4</sub> (45)	<sup>13</sup> / <sub>4</sub> (45)	<sup>13</sup> / <sub>4</sub> (45)	<sup>13</sup> / <sub>4</sub> (45)	<sup>13</sup> / <sub>4</sub> (45)	<sup>13</sup> / <sub>4</sub> (45)	<sup>23</sup> / <sub>4</sub> (70)	<sup>23</sup> / <sub>4</sub> (70)	<sup>23</sup> / <sub>4</sub> (70)		
Max. torque, reduced <sup>1</sup>	<i>T</i> <sub>max,red</sub>	ft-lbs	7 [5] <sup>3</sup>	14	27	47	56	74	90	126	126		

PARAMETER	SYMBOL	UNITS	METRIC NOMINAL ROD DIAMETER / REINFORCING BAR SIZE													
			M10	Ø10	M12	Ø12	Ø14	M16	Ø16	M20	Ø20	M24	Ø25	M27	Ø28	M30
Threaded rod outside diameter	<i>d</i>	mm (inch)	10 (0.39)	12 (0.47)	-	16 (0.63)	20 (0.79)	24 (0.94)	-	27 (1.06)	-	30 (1.18)	-			
Rebar nominal outside diameter	<i>d</i>	mm (inch)	10.0 (0.394)	12.0 (0.472)	14.0 (0.551)	16.0 (0.630)	20.0 (0.787)	-	25.0 (0.984)	-	28.0 (1.102)	-	32.0 (1.260)			
Carbide drill bit nominal size <sup>6</sup>	<i>d</i> <sub>bit</sub> ( <i>d</i> <sub>o</sub> )	mm	12   14	14   16	18	18   20	24   25	28	32	32	35	35	38			
Minimum embedment	<i>h</i> <sub>ef,min</sub>	mm (inch)	60 (2.4)	70 (2.8)	70 (2.8)	80 (3.2)	90 (3.6)	96 (3.8)	100 (3.9)	108 (4.3)	112 (4.4)	120 (4.7)	128 (5.0)			
Maximum embedment	<i>h</i> <sub>ef,max</sub>	mm (inch)	200 (7.8)	240 (14.8)	280 (11.0)	320 (12.6)	400 (15.8)	480 (18.8)	500 (19.6)	540 (21.4)	560 (22.0)	600 (23.6)	640 (25.2)			
Minimum member thickness	<i>h</i> <sub>min</sub>	mm (inch)	<i>h</i> <sub>ef</sub> + 30 ( <i>h</i> <sub>ef</sub> + <sup>1</sup> / <sub>4</sub> )			<i>h</i> <sub>ef</sub> + 2 <i>d</i> <sub>o</sub>										
Minimum anchor spacing	<i>S</i> <sub>min</sub>	mm (inch)	50 (2.0)	60 (2.4)	70 (3.7)	80 (3.2)	100 (4.0)	120 (4.8)	125 (4.9)	135 (5.3)	140 (5.5)	150 (5.9)	160 (6.3)			
Minimum edge distance	<i>C</i> <sub>min</sub>	mm (inch)	50 (2.0)	60 (2.4)	70 (3.7)	80 (3.2)	100 (4.0)	120 (4.8)	125 (4.9)	135 (5.3)	140 (5.5)	150 (5.9)	160 (6.3)			
Max. torque <sup>1</sup>	<i>T</i> <sub>max</sub>	N-m	20	40	60	80	120	160	160	180	180	200	300			
Max. torque <sup>1,3</sup> (low strength rod)	<i>T</i> <sub>max</sub>	N-m	7	20	-	40	100	160	-	180	-	200	-			
Minimum edge distance, reduced <sup>4</sup>	<i>C</i> <sub>min,red</sub>	mm (inch)	45 (1 <sup>3</sup> / <sub>4</sub> )	45 (1 <sup>3</sup> / <sub>4</sub> )	45 (1 <sup>3</sup> / <sub>4</sub> )	45 (1 <sup>3</sup> / <sub>4</sub> )	45 (1 <sup>3</sup> / <sub>4</sub> )	45 (1 <sup>3</sup> / <sub>4</sub> )	45 (1 <sup>3</sup> / <sub>4</sub> )	45 (1 <sup>3</sup> / <sub>4</sub> )	70 (2 <sup>3</sup> / <sub>4</sub> )	70 (2 <sup>3</sup> / <sub>4</sub> )	70 (2 <sup>3</sup> / <sub>4</sub> )			
Max. torque, reduced <sup>1</sup>	<i>T</i> <sub>max,red</sub>	N-m	9 [7] <sup>3</sup>	18	27	36	54	72	72	81	81	90	135			

For **pound-inch** units: 1 mm = 0.03937 inch, 1 N-m = 0.7375 ft-lbf. For **SI**: 1 inch = 25.4 mm, 1 ft-lbf = 1.356 N-m.

<sup>1</sup>Torque may not be applied to the anchors until the full cure time of the adhesive has been achieved.

<sup>2</sup>These torque values apply to ASTM A36 / F1554 Grade 36 carbon steel threaded rods; ASTM F1554 Grade 55 carbon steel threaded rods; and ASTM A193 Grade B8/B8M (Class 1) stainless steel threaded rods.

<sup>3</sup>These torque values apply to ASTM A193 Grade B8/B8M (Class 1) stainless steel threaded rod only.

<sup>4</sup>See Section 4.1.9 of this report for requirements of anchors installed at reduced edge distances.

<sup>5</sup>Either drill bit size listed is acceptable for threaded rod <sup>5</sup>/<sub>8</sub>-inch diameter and rebar size No. 5.

<sup>6</sup>For any case, it must be possible for the steel anchor element to be inserted into the cleaned drill hole without resistance.

<sup>7</sup>The DEWALT DustX+ extraction system can be used to automatically clean holes drilled in concrete with a hammer-drill. See [Figure A](#) for an illustration of the DustX+ extraction system. The DustX+ extraction system is qualified for use in dry concrete and water saturated concrete, however, drilling in dry concrete is recommended by DEWALT when using hollow drill bits.



FIGURE 2—PURE110+ EPOXY ADHESIVE ANCHOR SYSTEM INCLUDING TYPICAL STEEL ANCHOR ELEMENTS

### Pure110+ Instruction Card

**DESCRIPTION:**  
Pure110+ is a high strength, 100% solids epoxy adhesive which is formulated for use in anchoring and rebar connection applications by trained professionals. Refer to installation instructions and SDS for additional detailed information.

**PRECAUTION:**  
Safety glasses, and dust masks should be used when drilling holes into concrete, stone and masonry. Wear gloves and safety glasses when handling and dispensing adhesive. Do not sand the adhesive and create silica dust which could be inhaled. Avoid skin and eye contact. Use a NIOSH-approved chemical mask to avoid respiratory discomfort if working indoors or in a confined area, or if sensitive to adhesive odors. Wash hands or other affected body parts with soap and water if skin contact occurs. Flush eyes with plenty of water and seek immediate medical attention if eye contact occurs. Move to fresh air if adhesive odor begins to cause discomfort.

**IMPORTANT!** Before using, read and review Safety Data Sheet (SDS). This product contains crystalline silica and as supplied does not pose a dust hazard. IARC classifies crystalline silica (quartz sand) as a Group 1 carcinogen based upon evidence among workers in industries where there has been long-term and chronic exposure (via inhalation) to silica dust, e.g. mining, quarry, stone crushing, refractory brick and pottery workers. This product does not pose a dust hazard; therefore, this classification is not relevant. However, if reacted (fully cured) product is further processed (e.g. sanded, drilled) be sure to wear proper respiratory and eye protection to avoid health risk.

**HANDLING AND STORAGE:**  
Store in a cool, dry, well ventilated area at temperatures between 41°F (5°C) and 86°F (30°C). Do not freeze. Store and keep away from flame, heat and light. Keep partially used containers closed when not in use. Protect from damage.

**Make expiration date on product label before use. Do not use expired product.** Partially used cartridges may be stored with hardened adhesive in the attached mixing nozzle. If the cartridge is reused, attach a new mixing nozzle and discard initial quantity of anchor adhesive as described in installation instructions.

DEWALT  
701 East Joppa Road  
Towson, MD 21286 U.S.A.  
anchors@DEWALT.com  
www.DEWALT.com  
P: (800) 524-3244 [J]

#### [I] Pure110+ epoxy system selection table

Tool	Size	Cat.#	Type	Cartridges Size	Mixing nozzles Cat.#
Manual	Heavy Duty	09437-PWR	Quik-Shot	9/8 fl.oz. or 9.6 fl.oz.	FFC1640000
Cordless	Crack Gun	DCE600D1	(optional)	13.5 fl.oz.	or 0900-PWR
Manual		DFC1610275	Dual tube	13.5 fl.oz.	
Manual		09400-PWR			
Cordless		09413-PWR	Dual tube	20.5 fl.oz.	09000-PWR
Cordless		DCE601D1			
Pneumatic	50.5 fl.oz.	09438-PWR	Dual tube	50.5 fl.oz.	09000-PWR

#### [II] Gel (working) times and curing times for adhesive

Temperature of base material	Gel (working) time	Full curing time
41°F	120 minutes	48 hours
50°F	90 minutes	24 hours
60°F	30 minutes	8 hours
68°F	25 minutes	6 hours
75°F	15 minutes	6 hours
85°F	12 minutes	4 hours
104°F	10 minutes	4 hours
110°F	43°C	



Linear interpolation for intermediate base material temperatures is possible.

#### [III] Hole cleaning tools and accessories for Adhesive Anchors 1.23.4.5.6.7

Fractional anchor sizes		Metric anchor sizes	
Rod dia. (No.)	Rebar size (No.)	Rod dia. (Ø)	Rebar size (Ø)
3/8	3	10	10
1/2	4	12	12
5/8	5	16	16
3/4	6	20	20
7/8	7	24	24
1	8	28	28
1 1/8	9	32	32
1 1/2	10	38	38
1 3/4	11	45	45
2	12	51	51
2 1/4	13	59	59
2 3/4	14	67	67
3	15	76	76
3 1/2	16	89	89
4	17	101	101
4 1/2	18	114	114
5	19	127	127
5 1/2	20	141	141
6	21	154	154
6 1/2	22	168	168
7	23	181	181
7 1/2	24	195	195
8	25	208	208
8 1/2	26	222	222
9	27	235	235
9 1/2	28	249	249
10	29	262	262
10 1/2	30	276	276
11	31	289	289
11 1/2	32	303	303
12	33	316	316
12 1/2	34	330	330
13	35	343	343
13 1/2	36	357	357
14	37	370	370
14 1/2	38	384	384
15	39	397	397
15 1/2	40	411	411
16	41	424	424
16 1/2	42	438	438
17	43	451	451
17 1/2	44	465	465
18	45	478	478
18 1/2	46	492	492
19	47	505	505
19 1/2	48	519	519
20	49	532	532
20 1/2	50	546	546
21	51	559	559
21 1/2	52	573	573
22	53	586	586
22 1/2	54	600	600
23	55	613	613
23 1/2	56	627	627
24	57	640	640
24 1/2	58	654	654
25	59	667	667
25 1/2	60	681	681
26	61	694	694
26 1/2	62	708	708
27	63	721	721
27 1/2	64	735	735
28	65	748	748
28 1/2	66	762	762
29	67	775	775
29 1/2	68	789	789
30	69	802	802
30 1/2	70	816	816
31	71	829	829
31 1/2	72	843	843
32	73	856	856
32 1/2	74	870	870
33	75	883	883
33 1/2	76	897	897
34	77	910	910
34 1/2	78	924	924
35	79	937	937
35 1/2	80	951	951
36	81	964	964
36 1/2	82	978	978
37	83	991	991
37 1/2	84	1005	1005
38	85	1018	1018
38 1/2	86	1032	1032
39	87	1045	1045
39 1/2	88	1059	1059
40	89	1072	1072
40 1/2	90	1086	1086
41	91	1099	1099
41 1/2	92	1113	1113
42	93	1126	1126
42 1/2	94	1140	1140
43	95	1153	1153
43 1/2	96	1167	1167
44	97	1180	1180
44 1/2	98	1194	1194
45	99	1207	1207
45 1/2	100	1221	1221
46	101	1234	1234
46 1/2	102	1248	1248
47	103	1261	1261
47 1/2	104	1275	1275
48	105	1288	1288
48 1/2	106	1302	1302
49	107	1315	1315
49 1/2	108	1329	1329
50	109	1342	1342
50 1/2	110	1356	1356
51	111	1369	1369
51 1/2	112	1383	1383
52	113	1396	1396
52 1/2	114	1410	1410
53	115	1423	1423
53 1/2	116	1437	1437
54	117	1450	1450
54 1/2	118	1464	1464
55	119	1477	1477
55 1/2	120	1491	1491
56	121	1504	1504
56 1/2	122	1518	1518
57	123	1531	1531
57 1/2	124	1545	1545
58	125	1558	1558
58 1/2	126	1572	1572
59	127	1585	1585
59 1/2	128	1599	1599
60	129	1612	1612
60 1/2	130	1626	1626
61	131	1639	1639
61 1/2	132	1653	1653
62	133	1666	1666
62 1/2	134	1680	1680
63	135	1693	1693
63 1/2	136	1707	1707
64	137	1720	1720
64 1/2	138	1734	1734
65	139	1747	1747
65 1/2	140	1761	1761
66	141	1774	1774
66 1/2	142	1788	1788
67	143	1801	1801
67 1/2	144	1815	1815
68	145	1828	1828
68 1/2	146	1842	1842
69	147	1855	1855
69 1/2	148	1869	1869
70	149	1882	1882
70 1/2	150	1896	1896
71	151	1909	1909
71 1/2	152	1923	1923
72	153	1936	1936
72 1/2	154	1950	1950
73	155	1963	1963
73 1/2	156	1977	1977
74	157	1990	1990
74 1/2	158	2004	2004
75	159	2017	2017
75 1/2	160	2031	2031
76	161	2044	2044
76 1/2	162	2058	2058
77	163	2071	2071
77 1/2	164	2085	2085
78	165	2098	2098
78 1/2	166	2112	2112
79	167	2125	2125
79 1/2	168	2139	2139
80	169	2152	2152
80 1/2	170	2166	2166
81	171	2179	2179
81 1/2	172	2193	2193
82	173	2206	2206
82 1/2	174	2220	2220
83	175	2233	2233
83 1/2	176	2247	2247
84	177	2260	2260
84 1/2	178	2274	2274
85	179	2287	2287
85 1/2	180	2301	2301
86	181	2314	2314
86 1/2	182	2328	2328
87	183	2341	2341
87 1/2	184	2355	2355
88	185	2368	2368
88 1/2	186	2382	2382
89	187	2395	2395
89 1/2	188	2409	2409
90	189	2422	2422
90 1/2	190	2436	2436
91	191	2449	2449
91 1/2	192	2463	2463
92	193	2476	2476
92 1/2	194	2490	2490
93	195	2503	2503
93 1/2	196	2517	2517
94	197	2530	2530
94 1/2	198	2544	2544
95	199	2557	2557
95 1/2	200	2571	2571
96	201	2584	2584
96 1/2	202	2598	2598
97	203	2611	2611
97 1/2	204	2625	2625
98	205	2638	2638
98 1/2	206	2652	2652
99	207	2665	2665
99 1/2	208	2679	2679
100	209	2692	2692
100 1/2	210	2706	2706
101	211	2719	2719
101 1/2	212	2733	2733
102	213	2746	2746
102 1/2	214	2760	2760
103	215	2773	2773
103 1/2	216	2787	2787
104	217	2800	2800
104 1/2	218	2814	2814
105	219	2827	2827
105 1/2	220	2841	2841
106	221	2854	2854
106 1/2	222	2868	2868
107	223	2881	2881
107 1/2	224	2895	2895
108	225	2908	2908
108 1/2	226	2922	2922
109	227	2935	2935
109 1/2	228	2949	2949
110	229	2962	2962
110 1/2	230	2976	2976
111	231	2989	2989
111 1/2	232	3003	3003
112	233	3016	3016
112 1/2	234	3030	3030</

# Pure110+ Instruction Card (continued)

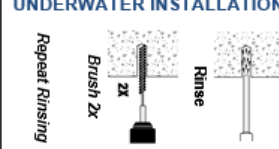
Installation instructions for Adhesive Anchors in solid base material – For any application not covered by this document please contact DEWALT

HOLE CLEANING UNDERWATER INSTALLATION	HOLE CLEANING DRY OR WET HOLES	HAMMER DRILLING
 <p><b>Rinse</b></p> <p><b>Brush 2x</b></p> <p>Repeat <b>Rinsing</b></p> <p>→ Next go to Step 3.</p>	 <p><b>Blow 2x</b></p> <p><b>Brush 2x</b></p> <p>Repeat <b>Blowing</b></p> <p>→ Next go to Step 3.</p>	 <p>→ In the case of an underwater (submerged) installation condition go to Step 2u-w-1 for separate specific hole cleaning instructions.</p>
<p><b>2u-w-ii:</b> Determine wire brush diameter (see Table III) for the drilled hole and attach the brush with adaptor to a rotary drill tool. Brush the hole with the selected wire brush a minimum of two times (2x).</p> <p>A brush extension (supplied by DEWALT) must be used for holes drilled deeper than the listed brush length. The wire brush diameter must be checked periodically during use. The brush should resist insertion into the drilled hole; if not the brush is too small and must be replaced with the proper brush diameter (i.e. new wire brush).</p> <p><b>2u-w-ii:</b> Repeat Step 2u-w-i again by rinsing the hole clean with air/water.</p> <p>When finished the hole should be clean and free of dust, debris, oil or other foreign material.</p>	<p><b>2d:</b> Determine wire brush diameter (see Table III) for the drilled hole and attach the brush with adaptor to a rotary drill tool or battery screw gun. Brush the hole with the selected wire brush a minimum of two times (2x).</p> <p>A brush extension (supplied by DEWALT) must be used for holes drilled deeper than the listed brush length. The wire brush diameter must be checked periodically during use; the brush should resist insertion into the drilled hole; if not the brush is too small and must be replaced with the proper brush diameter (i.e. new wire brush).</p> <p><b>2e:</b> Repeat Step 2a again by blowing the hole clean a minimum of two times (2x).</p> <p>When finished the hole should be clean and free of dust, debris, oil or other foreign material.</p>	<p><b>2a:</b> Starting from the bottom or back of the drilled anchor hole, blow the hole clean a minimum of two times (2x).</p> <p>Use a compressed air nozzle (min. 90 psf) for all sizes of anchor rod and reinforcing bar (rebar).</p>

This section is intentionally left blank.

**SELECT HAMMER DRILLING AS SUITABLE FOR APPLICATION**

**FOLLOW STEPS #1 THROUGH #10 FOR RECOMMENDED INSTALLATION**

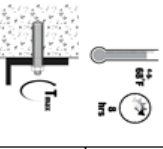
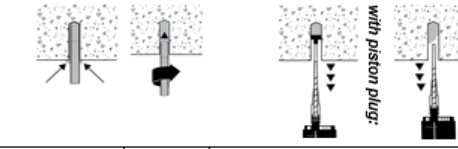
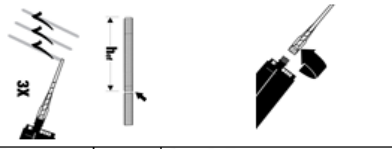
CURING & FIXTURE	INSTALLATION	PREPARING
 <p><b>10</b> After full curing of the adhesive anchor, a fixture can be installed to the anchor and tightened up to the maximum torque (shown in Table III) by using a calibrated torque wrench.</p> <p><b>Note:</b> Take care not to exceed the maximum torque for the selected anchor.</p>	 <p><b>with piston plug:</b></p> <p><b>7</b> The anchor should be free of dirt, grease, oil or other foreign material. Push clean threaded rod or reinforcing bar into the anchor hole while turning slightly to ensure positive distribution of the adhesive until the embedment depth is reached. Observe the gel (working) time.</p> <p><b>8</b> Ensure that the anchor element is installed to the specified embedment depth. Adhesive must completely fill the annular gap at the concrete surface. Following installation of the anchor element, remove excess adhesive. Protect the anchor element threads from fouling with adhesive.</p> <p>For all installations the anchor element must be restrained from movement throughout the specified curing period (where necessary) through the use of temporary wedges, external supports, or other methods. Minor adjustments to the position of the anchor element may be performed during the gel (working) time only.</p> <p><b>9</b> Allow the adhesive anchor to cure to the specified full curing time prior to applying any load (see Table IV).</p> <p><b>Note:</b> Do not disturb, torque or load the anchor until it is fully cured.</p>	 <p><b>1</b> Check adhesive expiration date on cartridge label. Do not use expired product. Review Safety Data Sheet (SDS) before use. Cartridge adhesive temperature must be between 50°F - 110°F (10°C - 43°C) when in use, for overhead applications cartridge adhesive temperature must be between 50°F - 90°F (10°C - 32°C) when in use. For best adhesive dispensing experience, suggested minimum cartridge adhesive temperature is 68°F (20°C) when in use. Review published gel (working) and cure times. Consideration should be given to the reduced gel (working) time of the adhesive in warm temperatures. For the permitted range of the base material temperature see Table II.</p> <p>Attach a supplied mixing nozzle to the cartridge. Do not modify the mixer in any way and make sure the mixing element is inside the nozzle. Load the cartridge into the correct dispensing tool.</p> <p><b>Note:</b> Always use a new mixing nozzle with new cartridges of adhesive and also for all work interruptions exceeding the published gel (working) time of the adhesive.</p> <p><b>2</b> Prior to inserting an anchor rod or rebar into the drilled hole, the position of the embedment depth has to be marked on the anchor. Verify anchor element is straight and free of surface damage.</p> <p><b>3</b> Adhesive must be properly mixed to achieve published properties. Prior to dispensing adhesive into the drilled hole, separately dispense at least three full strokes of adhesive through the mixing nozzle until the adhesive is a consistent red color.</p> <p>Review and note the published gel (working) and cure times prior to injection of the mixed adhesive into the cleaned anchor hole (see Table II).</p> <p><b>4</b> Fill the cleaned hole approximately two-thirds full with mixed adhesive starting from the bottom or back of the anchor hole. A plastic extension tube must be used with the mixing nozzle if the bottom or back of the anchor hole is not reached with the mixing nozzle only (see Table III). Slowly withdraw the mixing nozzle as the hole fills to avoid creating air pockets or voids.</p> <p><b>Note:</b> Piston plugs must be used with and attached to mixing nozzle and extension tube for overhead (i.e. upwardly inclined) installations and horizontal installations with anchor rod sizes as indicated in Table III. Insert piston plug to the back of the drilled hole and inject as described in the method above. During injection of the adhesive the piston plug will be naturally extruded from the drilled hole by the adhesive pressure. The use of piston plugs is also recommended for underwater installations where one is tabulated together with the anchor size (see Table III).</p> <p><b>Attention!</b> Do not install anchors overhead without proper training, and installation hardware provided by DEWALT, contact DEWALT prior to use.</p>

**FIGURE 4A—PURE110+® EPOXY ADHESIVE ANCHOR SYSTEM MANUFACTURER'S PUBLISHED INSTALLATION INSTRUCTIONS (MPII) (Continued)**

TABLE 13—DEVELOPMENT LENGTHS FOR COMMON REINFORCING BAR CONNECTIONS PROVIDED FOR ILLUSTRATION<sup>1,2,3,7</sup>

FRACTIONAL REINFORCING BARS													
DESIGN INFORMATION	SYMBOL	REFERENCE STANDARD	UNITS	NOMINAL REBAR SIZE (US)									
				#3	#4	#5	#6	#7	#8	#9	#10	#11	
Nominal rebar diameter	$d_b$	ASTM A615/A706, Grade 60 ( $f_y = 60$ ksi)	in. (mm)	0.375 (9.5)	0.500 (12.7)	0.625 (15.9)	0.750 (19.1)	0.875 (22.2)	1.000 (25.4)	1.128 (28.6)	1.270 (32.3)	1.410 (35.8)	
Nominal rebar area	$A_b$		in <sup>2</sup> (mm <sup>2</sup> )	0.11 (71)	0.20 (127)	0.31 (198)	0.44 (285)	0.60 (388)	0.79 (507)	1.00 (645)	1.27 (817)	1.56 (1006)	
Development length in $f_c = 2,500$ psi concrete <sup>4,5</sup>	$l_d$	ACI 318-19 25.4.2.4	in. (mm)	12.0 (305)	14.4 (366)	18.0 (457)	21.6 (549)	31.5 (800)	36.0 (914)	40.6 (1031)	45.7 (1161)	50.8 (1290)	
Development length in $f_c = 3,000$ psi concrete <sup>4,5</sup>			in. (mm)	12.0 (305)	13.1 (334)	16.4 (417)	19.7 (501)	28.8 (730)	32.9 (835)	37.1 (942)	41.7 (1060)	46.3 (1177)	
Development length in $f_c = 4,000$ psi concrete <sup>4,5</sup>			in. (mm)	12.0 (305)	12.0 (305)	14.2 (361)	17.1 (434)	24.9 (633)	28.5 (723)	32.1 (815)	36.2 (920)	40.1 (1019)	
Development length in $f_c = 6,000$ psi concrete <sup>4,5</sup>			in. (mm)	12.0 (305)	12.0 (305)	12.0 (305)	13.9 (354)	20.3 (516)	23.2 (590)	26.2 (666)	29.5 (750)	32.8 (832)	
Development length in $f_c = 8,000$ psi concrete <sup>4,5</sup>			in. (mm)	12.0 (305)	12.0 (305)	12.0 (305)	12.1 (307)	17.6 (443)	20.1 (511)	22.7 (577)	25.6 (649)	28.4 (721)	

METRIC REINFORCING BARS														
DESIGN INFORMATION	SYMBOL	REFERENCE STANDARD	UNITS	NOMINAL REBAR SIZE (EU)										
				Ø10	Ø12	Ø14	Ø16	Ø20	Ø24	Ø25	Ø28	Ø32	Ø34	Ø36
Nominal rebar diameter	$d_b$	DIN 488, BSt 500 (BS 4449: 2005) ( $f_y = 72.5$ ksi)	mm (in)	10 (0.394)	12 (0.472)	14.0 (0.551)	16 (0.630)	20 (0.787)	24 (0.945)	25 (0.984)	28 (1.102)	32 (1.260)	34 (1.339)	36 (1.417)
Nominal rebar area	$A_b$		mm <sup>2</sup> (in <sup>2</sup> )	78.5 (0.12)	113 (0.18)	154 (0.23)	201 (0.31)	314 (0.49)	452 (0.70)	491 (0.76)	616 (0.96)	804 (1.25)	908 (1.41)	1018 (1.58)
Development length in $f_c = 2,500$ psi concrete <sup>4,6</sup>	$l_d$	ACI 318-19 25.4.2.4	mm (in)	348 (13.7)	417 (16.4)	487 (19.2)	556 (21.9)	870 (34.2)	1044 (41.1)	1087 (42.8)	1217 (47.9)	1392 (54.8)	1479 (58.2)	1566 (61.6)
Development length in $f_c = 3,000$ psi concrete <sup>4,6</sup>			mm (in)	318 (12.5)	381 (15.0)	445 (17.5)	508 (20.0)	794 (31.3)	953 (37.5)	992 (39.1)	1112 (43.8)	1271 (50.0)	1351 (53.2)	1429 (56.3)
Development length in $f_c = 4,000$ psi concrete <sup>4,6</sup>			mm (in)	305 (12.0)	330 (13.0)	385 (15.2)	439 (17.3)	688 (27.1)	825 (32.5)	859 (33.8)	963 (37.9)	1100 (43.3)	1170 (46.0)	1238 (48.7)
Development length in $f_c = 6,000$ psi concrete <sup>4,6</sup>			mm (in)	305 (12.0)	305 (12.0)	314 (12.4)	359 (14.2)	562 (22.1)	674 (26.4)	702 (27.6)	786 (30.9)	899 (35.4)	955 (37.6)	1011 (39.8)
Development length in $f_c = 8,000$ psi concrete <sup>4,6</sup>			mm (in)	305 (12.0)	305 (12.0)	305 (12.0)	311 (12.3)	486 (29.1)	584 (23.0)	608 (23.9)	681 (26.8)	778 (30.6)	827 (32.6)	875 (34.5)

DESIGN INFORMATION	SYMBOL	REFERENCE STANDARD	UNITS	NOMINAL REBAR SIZE (CA)					
				10M	15M	20M	25M	30M	35M
Nominal rebar diameter	$d_b$	CAN/CSA G30.18, Grade 400 ( $f_y = 58$ ksi)	mm (in)	11.3 (0.445)	16.0 (0.630)	19.5 (0.768)	25.2 (0.992)	29.9 (1.177)	35.7 (1.406)
Nominal rebar area	$A_b$		mm <sup>2</sup> (in <sup>2</sup> )	100 (0.16)	200 (0.31)	300 (0.46)	500 (0.77)	700 (1.09)	1000 (1.56)
Development length in $f_c = 2,500$ psi concrete <sup>4,6</sup>	$l_d$	ACI 318-19 25.4.2.4	mm (in)	315 (12.4)	445 (17.5)	678 (26.7)	876 (34.5)	1041 (41.0)	1242 (48.9)
Development length in $f_c = 3,000$ psi concrete <sup>4,6</sup>			mm (in)	305 (12.0)	407 (16.0)	620 (24.4)	800 (31.5)	950 (37.4)	1135 (44.7)
Development length in $f_c = 4,000$ psi concrete <sup>4,6</sup>			mm (in)	305 (12.0)	353 (13.9)	536 (21.1)	693 (27.3)	823 (32.4)	983 (38.7)
Development length in $f_c = 6,000$ psi concrete <sup>4,6</sup>			mm (in)	305 (12.0)	305 (12.0)	438 (17.3)	566 (22.3)	672 (26.4)	802 (31.6)
Development length in $f_c = 8,000$ psi concrete <sup>4,6</sup>			mm (in)	305 (12.0)	305 (12.0)	379 (14.9)	490 (19.3)	582 (22.9)	695 (27.4)

For **SI**: 1 inch  $\equiv$  25.4 mm, 1 lbf = 4.448 N, 1 psi = 0.006897 MPa; for **pound-inch** units: 1 mm = 0.03937 inches, 1 N = 0.2248 lbf, 1 MPa = 145.0 psi.

- <sup>1</sup>Calculated development lengths in accordance with Section 4.2.2 of this report and ACI 318-19 Section 25.4.2.4 for reinforcing bars are valid for static, wind, and earthquake loads.
- <sup>2</sup>Calculated development lengths in SDC C through F must comply with ACI 318-19 Chapter 18 and Section 4.2.4 of this report. Post-installed reinforcing bars may be installed into holes drilled with a hammer-drill (i.e. rotary impact drills or rock drills with a carbide drill bit, including hollow drill bits) or a core-drill (i.e. core drill with a diamond core drill bit).
- <sup>3</sup>For Class B splices, minimum length of lap for tension lap splices is  $1.3l_d$  in accordance with ACI 318-19 Section 25.5.2.
- <sup>4</sup>For lightweight concrete,  $\lambda = 0.75$ ; therefore multiply development lengths by 1.33 (increase development length by 33 percent), unless the provisions of ACI 318-19 Section 25.4.2.5 are met to permit alternate values of  $\lambda$  (e.g for sand-lightweight concrete,  $\lambda = 0.85$ ; therefore multiply development lengths by 1.18). Refer to ACI 318-19 Section 19.2.4 .
- <sup>5</sup> $\left(\frac{c_b + K_{tr}}{d_b}\right) = 2.5$ ,  $\psi_t = 1.0$ ,  $\psi_e = 1.0$ ,  $\psi_s = 0.8$  for  $d_b \leq \#6$ , 1.0 for  $d_b > \#6$ . Refer to ACI 318-19 Section 25.4.2.5.
- <sup>6</sup> $\left(\frac{c_b + K_{tr}}{d_b}\right) = 2.5$ ,  $\psi_t = 1.0$ ,  $\psi_e = 1.0$ ,  $\psi_s = 0.8$  for  $d_b \leq 19$  mm, 1.0 for  $d_b > 19$  mm. Refer to ACI 318-19 Section 25.4.2.5.
- <sup>7</sup>Calculations may be performed for other steel grades and concrete compressive strengths per ACI 318-19 Chapter 25.

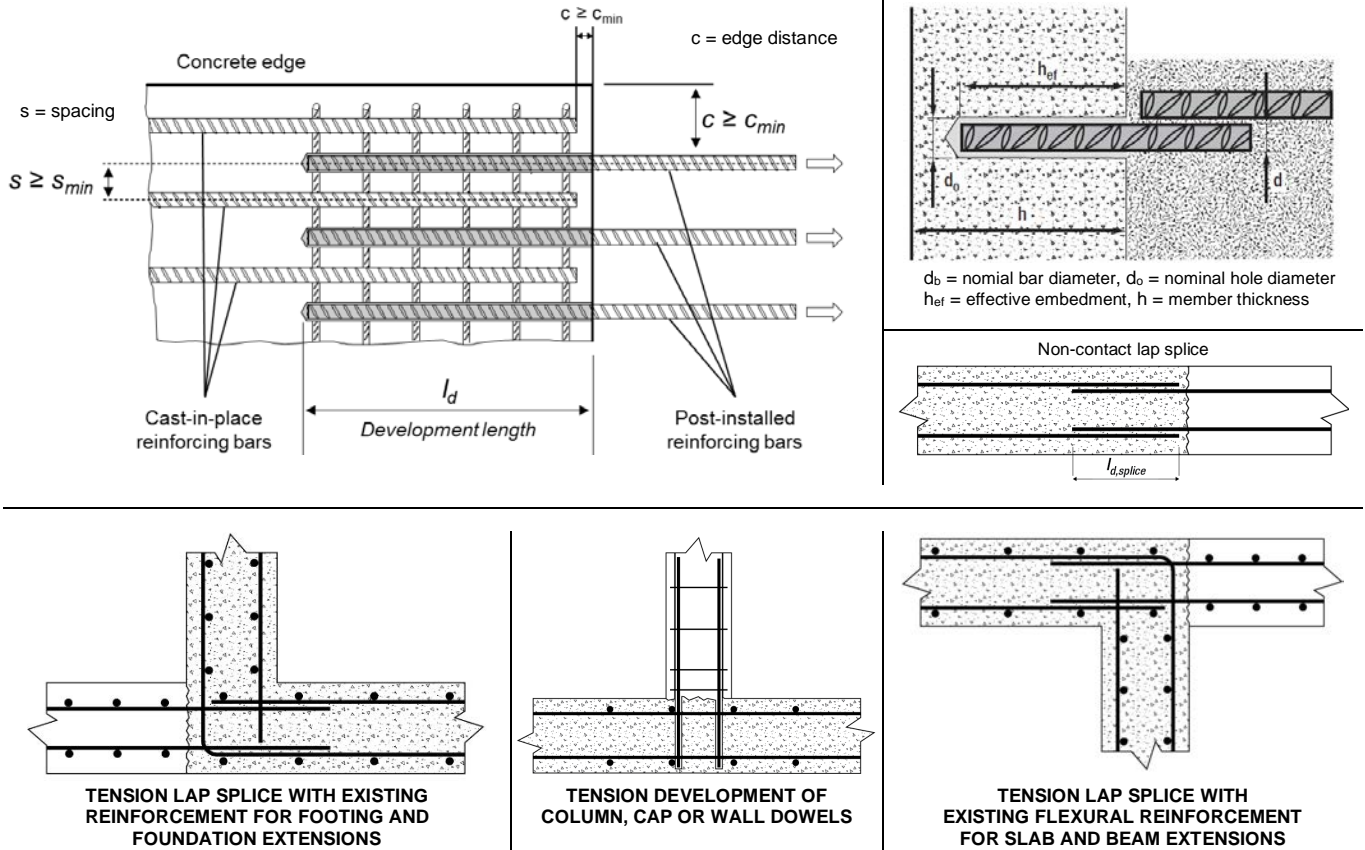

FIGURE 3—INSTALLATION DETAIL FOR POST-INSTALLED REINFORCING BAR CONNECTIONS (Top Pictures), EXAMPLES OF DEVELOPMENT LENGTH APPLICATION DETAILS FOR POST-INSTALLED REINFORCING BAR CONNECTIONS PROVIDED FOR ILLUSTRATION (Bottom Pictures)

TABLE 14—INSTALLATION PARAMETERS FOR COMMON POST-INSTALLED REINFORCING BAR CONNECTIONS<sup>4</sup>

FRACTIONAL REINFORCING BARS											
PARAMETER	SYMBOL	UNIT	NOMINAL REBAR SIZE (US)								
			#3	#4	#5	#6	#7	#8	#9	#10	#11
Nominal hole diameter <sup>1,3</sup>	$d_o$	in.	7/16	5/8	3/4	7/8	1	1 1/8	1 3/8	1 1/2	1 3/4
Effective embedment <sup>2,3</sup>	$h_{ef}$	in.	Up to 7 1/2	Up to 10	Up to 12 1/2	Up to 15	Up to 17 1/2	Up to 20	Up to 22 1/2	Up to 25	Up to 27 1/2
Nominal hole diameter <sup>1,3</sup>	$d_o$	in.	1/2	5/8	3/4	1	1 1/8	1 1/4	1 3/8	1 1/2	1 3/4
Effective embedment <sup>2,3</sup>	$h_{ef}$	in.	Up to 22 1/2	Up to 30	Up to 37 1/2	Up to 45	Up to 52 1/2	Up to 60	Up to 67 1/2	Up to 75	Up to 82 1/2

METRIC REINFORCING BARS													
PARAMETER	SYMBOL	UNITS	NOMINAL REBAR SIZE (EU)										
			Ø10	Ø12	Ø14	Ø16	Ø20	Ø24	Ø25	Ø28	Ø32	Ø34	Ø36
Nominal hole diameter <sup>1</sup>	$d_o$	mm	14	16	18	20	25	32	32	35	40	42	45
Effective embedment <sup>2</sup>	$h_{ef}$	mm	Up to 600	Up to 720	Up to 840	Up to 1200	Up to 1440	Up to 1500	Up to 1500	Up to 1680	Up to 1920	Up to 2040	Up to 2160

PARAMETER	SYMBOL	UNITS	NOMINAL REBAR SIZE (CA)					
			10M	15M	20M	25M	30M	35M
Nominal hole diameter <sup>1</sup>	$d_o$	in.	9/16	3/4	1	1 1/4	1 1/2	1 3/4
Effective embedment <sup>2</sup>	$h_{ef}$	mm	Up to 678	Up to 960	Up to 1170	Up to 1512	Up to 1794	Up to 2100

For SI: 1 inch ≅ 25.4 mm.; for pound-inch units: 1 mm = 0.03937 inches.

<sup>1</sup>For any case, it must be possible for the reinforcing bar (rebar) to be inserted into the cleaned drill hole without resistance.

<sup>2</sup>Consideration should be given regarding the commercial availability of carbide drill bits (including hollow bits) and diamond core drill bits, as applicable, with lengths necessary to achieve the effective embedments for post-installed reinforcing bar connections.

<sup>3</sup>For fractional reinforcing bars where the effective embedment is listed for two nominal hole diameters, either nominal hole diameter may be used.

<sup>4</sup>The DEWALT DustX+ extraction system can be used to automatically clean holes drilled in concrete with a hammer-drill. See Figure A for an illustration of the DustX+ extraction system. The DustX+ extraction system is qualified for use in dry concrete and water saturated concrete, however, drilling in dry concrete is recommended by DEWALT when using hollow drill bits.

### Pure110+ Post-Installed Rebar Connections

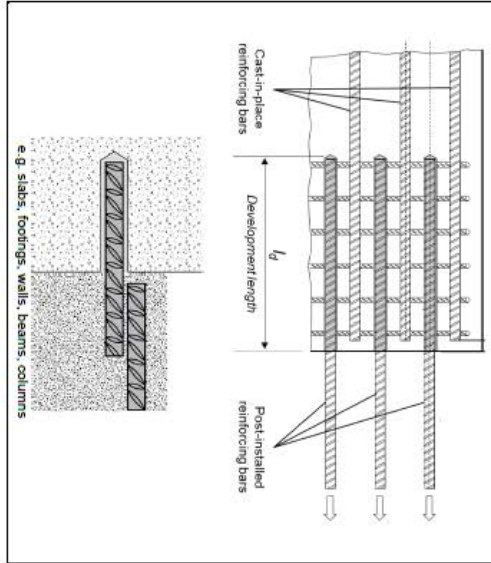

#### [V] Pure110+ epoxy system selection table

Tool	Size	Dispensers	Cat.#	Type	Cartridges	Size	Mixing nozzles	Cat.#
Manual	Heavy Duty	09437-PWR	Quick-shot	9 fl.oz. or 9.5 fl.oz.	PFC1640900			
Manual	Caulk Gun	DCCE600D1	(coaxial)	9.5 fl.oz.	or 08008-PWR			
Manual	13.5 fl.oz.	08298-PWR	Dual tube	13.5 fl.oz.				
Manual	20.5 fl.oz.	09409-PWR	Dual tube	20.5 fl.oz.	08009-PWR			
Pneumatic	20.5 fl.oz.	09413-PWR	Dual tube	20.5 fl.oz.				
Condless		DCCE610D1						
Pneumatic	50.5 fl.oz.	09439-PWR	Dual tube	50.5 fl.oz.	08009-PWR			

#### [VI] Gel (working) times and curing times for adhesive

Temperature of base material	Gel (working) time	Full curing time	
41°F	120 minutes	48 hours	
50°F	10°C	90 minutes	24 hours
68°F	20°C	25 minutes	8 hours
86°F	30°C	20 minutes	6 hours
95°F	35°C	15 minutes	6 hours
104°F	40°C	12 minutes	4 hours
110°F	43°C	10 minutes	4 hours

Linear interpolation for intermediate base material temperatures is possible.

#### [VII] Hole cleaning tools and accessories for Post-Installed Rebar Connections<sup>1,2,3,4,5,6,7</sup>

Rebar size (No.)	Fractional reinforcing bar sizes			Metric reinforcing bar sizes										
	Drill bit size (inch)	Brush size (inch)	Wire plug size (inch)	Rebar size (mm)	Drill bit size (mm)	Brush size (mm)	Wire brush size (mm)	Wire brush (Cat.#)	Plug size (mm)	Piston plug (Cat.#)				
3	7/16	7/16	63/4	Ø10	Ø12	Ø14	Ø16	Ø20	Ø24	Ø25	Ø28	Ø32	Ø34	Ø36
4	5/8	5/8	63/4	14	16	18	20	25	32	35	40	42	42	45
5	3/4	3/4	73/8	16	18	20	22	28	32	35	40	42	42	45
6	7/8	7/8	73/8	20	22	25	28	35	40	42	45	45	45	45
7	1	1	11/2	24	28	32	35	40	45	45	45	45	45	45
8	1 1/8	1 1/8	1 1/8	28	32	35	40	45	45	45	45	45	45	45
9	1 1/4	1 1/4	1 1/4	32	35	40	45	45	45	45	45	45	45	45
10	1 1/2	1 1/2	1 1/2	34	42	42	42	42	42	42	42	42	42	42
11	1 3/4	1 3/4	1 3/4	36	45	45	45	45	45	45	45	45	45	45

<sup>1</sup>If the DEWALT DustX+ extraction system is used to automatically clean the holes during drilling, standard hole cleaning (brushing and blowing following drilling) is not required. <sup>2</sup>Holes are drilled with hammer-drilling (i.e. rotary impact drills or rock drills with a carbide drill bit, including the use of hollow drill bits) or core-drilling (i.e. core drill with a diamond core drill bit). <sup>3</sup>For any case, it must be possible for the reinforcing bar to be inserted into the cleaned hole without resistance. <sup>4</sup>A brush extension (Cat.# 08282) must be used with a steel wire brush for holes drilled deeper than the listed brush length. <sup>5</sup>Brush adaptors for power tool connectors are available for drill chuck (Cat.# 08295) and SDS (Cat.# 08283). <sup>6</sup>A flexible extension tube (Cat.# 08297) or flexible extension hose (Cat.# PFC1640900) or equivalent approved by DEWALT must be used with the mixing nozzle if the bottom of the anchor hole is not reached with the mixing nozzle only. <sup>7</sup>All overhead (i.e. upwardly inclined) installations require the use of piston plugs during where one is tabulated together with the anchor size (see table). N/A = Not applicable. All horizontal installations require the use of piston plugs where one is tabulated together with the anchor size and where the embedment depth is greater than 8 inches. A flexible extension tube (Cat.# 08297) or flexible extension hose (Cat.# PFC1640900) or equivalent approved by DEWALT must be used with piston plugs.

#### [VIII] Installation parameters - Specifications for installation of reinforcing bars for Post-Installed Rebar Connections

PARAMETER	SYMBOL	UNITS	FRACTIONAL REINFORCING BARS										
			#3	#4	#5	#6	#7	#8	#9	#10	#11		
Nominal hole diameter <sup>1,2</sup>	d <sub>h</sub>	in.	7/8	5/8	3/4	7/8	1	1 1/8	1 1/8	1 1/2	1 1/2	1 3/4	1 3/4
Effective embedment <sup>1,2,3</sup>	h <sub>ef</sub>	in.	Up to 7 1/2	Up to 10	Up to 12 1/2	Up to 15	Up to 17 1/2	Up to 20	Up to 22 1/2	Up to 25	Up to 27 1/2	Up to 27 1/2	Up to 27 1/2
Nominal hole diameter <sup>1,3</sup>	d <sub>h</sub>	in.	1/2	5/8	3/4	1	1 1/8	1 1/8	1 1/2	1 1/2	1 3/4	1 3/4	1 3/4
Effective embedment <sup>1,2,3</sup>	h <sub>ef</sub>	in.	Up to 22 1/2	Up to 30	Up to 37 1/2	Up to 45	Up to 52 1/2	Up to 60	Up to 67 1/2	Up to 75	Up to 82 1/2	Up to 82 1/2	Up to 82 1/2

PARAMETER	SYMBOL	UNITS	METRIC REINFORCING BARS										
			Ø10	Ø12	Ø14	Ø16	Ø20	Ø24	Ø25	Ø28	Ø32	Ø34	Ø36
Nominal hole diameter <sup>1</sup>	d <sub>h</sub>	mm	14	16	18	20	25	32	32	35	40	42	45
Effective embedment <sup>1,2</sup>	h <sub>ef</sub>	mm	Up to 600	Up to 720	Up to 840	Up to 1200	Up to 1440	Up to 1500	Up to 1500	Up to 1680	Up to 1920	Up to 2040	Up to 2160

PARAMETER	SYMBOL	UNITS	NOMINAL REBAR SIZE (US)										
			10M	15M	20M	25M	30M	35M					
Nominal hole diameter <sup>1</sup>	d <sub>h</sub>	in.	3/4	1	1 1/4	1 1/4	1 1/2	1 3/4	1 3/4	1 3/4	1 3/4	1 3/4	
Effective embedment <sup>1,2</sup>	h <sub>ef</sub>	mm	Up to 578	Up to 960	Up to 1170	Up to 1512	Up to 1794	Up to 1794	Up to 1794	Up to 1794	Up to 1794	Up to 2100	

<sup>1</sup>For SI: 1 inch = 25.4 mm.; for pound-inch units: 1 mm = 0.03937 inches.  
<sup>2</sup>For any case, it must be possible for the reinforcing bar (rebar) to be inserted into the cleaned drill hole without resistance.  
<sup>3</sup>Consideration should be given regarding the commercial availability of carbide drill bits (including hollow bits) and diamond core drill bits, as applicable, with lengths necessary to achieve the effective embedment for post-installed reinforcing bar connections.  
<sup>4</sup>For fractional reinforcing bars where the effective embedment is listed for two nominal hole diameters, either nominal hole diameter may be used.

FIGURE 4B—PURE110+® EPOXY ADHESIVE POST-INSTALLED REINFORCING BAR CONNECTIONS MANUFACTURER'S PUBLISHED INSTALLATION INSTRUCTIONS (MPII)

# Pure110+ Post-installed Rebar Connections (cont.)

Installation instructions for Post-Installed Rebar Connections in solid base material (e.g. bar development and lap splice connections)

SELECT HAMMER DRILLING OR CORE DRILLING AS SUITABLE FOR APPLICATION		FOLLOW STEPS #1 THROUGH #10 FOR RECOMMENDED INSTALLATION	
<p><b>HOLE CLEANING CORE DRILLED HOLES</b></p> <p>Repeat Rinsing Brush 2x Repeat Rinsing Blow 2x Repeat Brushing 2x Repeat Blowing 2x</p>	<p><b>CORE DRILLING</b></p>	<p><b>HOLE CLEANING DRY OR WET HOLES</b></p> <p>Blow 2x Brush 2x Repeat Blowing 2x</p>	<p><b>HAMMER DRILLING</b></p>
<p><b>1a.</b> Drill a hole into the base material with rotary hammer drill (i.e. percussive drill) and a carbide drill bit to the size and embedment required by the selected reinforcing bar (see Table VII). Tolerances of carbide drill bits including hollow drill bits must meet ANSI Standard B21.2-15.</p> <p><b>Precaution:</b> Wear suitable eye and skin protection. Avoid inhalation of dusts during drilling and/or removal (see dust extraction equipment by DEWALT to minimize dust emissions).</p> <p><b>Notes:</b> In case of standing water in the drilled hole (flooded hole condition), all the water has to be removed from the hole (e.g. vacuum, compressed air, etc.) prior to cleaning. Drilling in dry concrete is recommended when using hollow drill bits (vacuum must be on).</p> <p>→ Go to Step 3 for holes drilled with DustX™ extraction system (no further hole cleaning is required). Otherwise go to Step 2a for hole cleaning instructions.</p>		<p><b>1a.</b> Starting from the bottom or back of the drilled hole, blow the hole clean a minimum of two times (2x).</p> <p><b>2a.</b> Determine wire brush diameter (see Table VII) for the drilled hole and attach the brush with adaptor to a rotary drill tool or battery screw gun. Brush the hole with the selected wire brush a minimum of two times (2x).</p> <p>A brush extension (supplied by DEWALT) must be used for holes drilled deeper than the listed brush length. The wire brush diameter must be checked periodically during use. The brush should resist insertion into the drilled hole, if not the brush is too small and must be replaced with the proper brush diameter (i.e. new wire brush).</p> <p><b>2c.</b> Repeat Step 2a again by blowing the hole clean a minimum of two times (2x). When finished the hole should be clean and free of dust, debris, oil or other foreign material. → Next go to Step 3.</p>	
<p><b>2b.</b> Determine wire brush diameter (see Table VII) for the drilled hole and attach the brush with adaptor to a rotary drill tool. Brush the hole with the selected wire brush a minimum of two times (2x).</p> <p><b>2c.</b> Repeat Step 2a again by rinsing the hole clean with air/water.</p> <p><b>2d.</b> Starting from the bottom or back of the drilled hole, blow the hole clean a minimum of two times (2x). Use a compressed air nozzle (min. 90 psi) for all sizes of reinforcing bar (rebar). When finished the hole should be clean and free of water, debris, oil or other foreign material.</p> <p><b>2e.</b> Repeat Step 2b again by brushing the hole with a wire brush a minimum of two times (2x).</p> <p><b>2f.</b> Repeat Step 2d again by blowing the hole clean a minimum of two times (2x).</p> <p>→ Next go to Step 3.</p>		<p><b>2.</b> Check adhesive expiration date on cartridge label. Do not use expired product. Review Safety Data Sheet (SDS) before use. Review published gel (working) and cure times. Cartridge adhesive temperature must be between 50°F - 110°F (10°C - 43°C) when in use; except for overhead applications cartridge adhesive temperature must be between 50°F - 90°F (10°C - 32°C) when in use. For best adhesive dispensing experience, the suggested minimum cartridge adhesive temperature is 68°F (20°C) when in use. Consideration should be given to the reduced gel (working) time of the adhesive in warm temperatures. For the permitted range of the base material temperature see Table VI.</p> <p>Attach a supplied mixing nozzle to the cartridge. Do not modify the mixer in any way and make sure the mixing element is inside the nozzle. Load the cartridge into the correct dispensing tool.</p> <p><b>Note:</b> Always use a new mixing nozzle with new cartridges of adhesive and also for all work interruptions exceeding the published gel (working) time of the adhesive.</p> <p><b>3.</b> Prior to inserting a rebar into the drilled hole, the position of the embedment depth has to be marked on the anchor. Verify rebar is straight and free of surface damage.</p> <p><b>4.</b> Adhesive must be properly mixed to achieve published properties. Prior to dispensing adhesive into the drilled hole, separately dispense at least three full strokes of adhesive through the mixing nozzle until the adhesive is a consistent red color. Review and note the published gel (working) and cure times prior to injection of the mixed adhesive into the cleaned anchor hole (see Table VI).</p> <p><b>5.</b> Fill the cleaned hole approximately two-thirds full with mixed adhesive starting from the bottom or back of the anchor hole. A plastic extension tube must be used with the mixing nozzle if the bottom or back of the anchor hole is not reached with the mixing nozzle only (see Table VII). Slowly withdraw the mixing nozzle as the hole fills to avoid creating air pockets or voids.</p> <p><b>Note:</b> Piston plugs must be used with and attached to mixing nozzle and extension tube for overhead (i.e. upwardly inclined) installations and horizontal installations with rebar sizes as indicated in Table III. Insert piston plug to the back of the drilled hole and inject as described in the method above. During injection of the adhesive the piston plug will be naturally extruded from the drilled hole by the adhesive pressure. <b>Attention!</b> Do not install anchors overhead without proper training, and installation hardware provided by DEWALT, contact DEWALT prior to use.</p> <p><b>7.</b> The reinforcing bar should be free of dirt, grease, oil or other foreign material. Push clean rebar into the anchor hole while turning slightly to ensure positive distribution of the adhesive until the embedment depth is reached. Observe the gel (working) time.</p> <p><b>8.</b> Ensure that the reinforcing bar is installed to the specified embedment depth. Adhesive must completely fill the annular gap at the concrete surface. Following installation of the rebar, remove excess adhesive.</p> <p>For all installations the rebar must be restrained from movement throughout the specified curing period (where necessary) through the use of temporary wedges, external supports, or other methods. Minor adjustments to the position of the rebar may be performed during the gel (working) time only.</p> <p><b>9.</b> Allow the rebar connection to cure to the specified full curing time prior to applying any load (see Table VI).</p> <p><b>Note:</b> Do not disturb, torque or load the anchor until it is fully cured.</p> <p><b>10.</b> After full curing of the rebar connection, new concrete can be poured (placed) to the installed rebar connection.</p>	
<p><b>CURING &amp; POUR</b></p>		<p><b>INSTALLATION</b></p> <p>with piston plug:</p>	
<p><b>PREPARING</b></p>		<p><b>11.</b> After full curing of the rebar connection, new concrete can be poured (placed) to the installed rebar connection.</p>	

FIGURE 4B—PURE110+® EPOXY ADHESIVE POST-INSTALLED REINFORCING BAR CONNECTIONS MANUFACTURER'S PUBLISHED INSTALLATION INSTRUCTIONS (MPII) (Continued)

**TABLE 15— APPLICABLE SECTIONS OF THE IBC CODE UNDER EACH EDITION OF THE IBC**

2024 IBC	2021 IBC	2018 IBC	2015 IBC
Section 1605.1		Section 1605.2 or 1605.3	
	Section 1705.1.1		
	Table 1705.3		
	Section 1705		
	Chapter 19		
	Section 1901.3		
	Section 1903		
	Section 1905		
Section 1905.7	Section 1905.1.8		

**TABLE 16— APPLICABLE SECTIONS OF ACI 318 UNDER EACH EDITION OF THE IBC**

2024 IBC	2021 IBC	2018 IBC	2015 IBC
<b>ACI 318-19</b>		<b>ACI 318-14</b>	
2.3		2.3	
5.3		5.3	
Chapter 17		Chapter 17	
17.2.4		17.2.6	
17.3.1		17.2.7	
17.5.1		17.3.1.1	
17.5.1.2		17.3.1	
17.5.3		17.3.3	
17.6.1.2		17.4.1.2	
Eq. 17.6.1.2		17.4.1.2	
17.6.2		17.4.2	
17.6.2.2		17.4.2.2	
17.6.2.5		17.4.2.6	
17.6.5		17.4.5	
Eq 17.6.5.1.2b		Eq 17.4.5.1d	
Eq 17.6.5.2.1		Eq 17.4.5.2	
17.6.5.5		17.4.5.5	
Eq. 17.6.5.5.1b		Eq. 17.4.5.5b	
Eq. 17.6.5.5.1c		Eq. 17.4.5.5c	
17.7.1.2		17.5.1.2	
Eq. 17.7.1.2(b)		Eq. 17.5.1.2b	
17.7.2		17.5.2	
17.7.2.2		17.5.2.2	
17.7.3		17.5.3	
17.8		17.6	
17.9.2		17.7.1 and 17.7.3	
17.9.3		17.7.4	
17.9.5		17.7.6	
17.10		17.2.3	
17.10.5.3(a)(vi),		17.2.3.4.3(a)vi	
Chapter 18		Chapter 18	
Chapter 19		Chapter 19	
19.2.4		19.2.4	
20.2.2.4 and 20.2.2.5		20.2.2.4 and 20.2.2.5	
Chapter 25		Chapter 25	
25.4.2.4		25.4.2.3	
25.4.2.5		25.4.2.4	
25.5.2		25.5.2	
26.6.3.2 (b)		26.6.3.1 (b)	
26.7.2		17.8.1 and 17.8.2	
26.7.1(l) and 26.7.2(e)		17.8.2.2 or 17.8.2.3	
26.13.3.2(e)		17.8.2.4, 26.7.1(h) and 26.13.3.2(c)	

**DIVISION: 03 00 00—CONCRETE**

Section: 03 16 00—Concrete Anchors

**DIVISION: 05 00 00—METALS**

Section: 05 05 19—Post-Installed Concrete Anchors

**REPORT HOLDER:**

DEWALT

**EVALUATION SUBJECT:****PURE110+® EPOXY ADHESIVE ANCHOR SYSTEM AND POST-INSTALLED REINFORCING BAR CONNECTIONS IN CRACKED AND UNCRACKED CONCRETE****1.0 REPORT PURPOSE AND SCOPE****Purpose:**

The purpose of this evaluation report supplement is to indicate that the Pure110+ Epoxy Adhesive Anchor System and Post-Installed Reinforcing Bar Connections in cracked and uncracked concrete, described in ICC-ES evaluation report [ESR-3298](#), have also been evaluated for compliance with the codes noted below as adopted by Los Angeles Department of Building and Safety (LADBS).

**Applicable code editions:**

- 2023 City of Los Angeles Building Code ([LABC](#))
- 2023 City of Los Angeles Residential Code ([LARC](#))

**2.0 CONCLUSIONS**

The Pure110+ Epoxy Adhesive Anchor System and Post-Installed Reinforcing Bar Connections in cracked and uncracked concrete, described in Sections 2.0 through 7.0 of the evaluation report [ESR-3298](#), comply with LABC Chapter 19, and the LARC, and are subjected to the conditions of use described in this supplement.

**3.0 CONDITIONS OF USE**

The Pure110+ Epoxy Adhesive Anchor System and Post-Installed Reinforcing Bar Connections described in this evaluation report supplement must comply with all of the following conditions:

- All applicable sections in the evaluation report [ESR-3298](#).
- The design, installation, conditions of use and labeling of the Pure110+ Epoxy Adhesive Anchor System and Post-Installed Reinforcing Bar Connections are in accordance with the 2021 *International Building Code*® (IBC) provisions noted in the evaluation report [ESR-3298](#).
- The design, installation and inspection are in accordance with additional requirements of LABC Chapters 16 and 17, as applicable.
- Under the LARC, an engineered design in accordance with LARC Section R301.1.3 must be submitted.
- The allowable and strength design values listed in the evaluation report and tables are for the connection of the steel anchors and post-installed reinforcing bars to the concrete. The connection between the steel anchors or post-installed reinforcing bars and the connected members shall be checked for capacity (which may govern).
- For use in wall anchorage assemblies to flexible diaphragm applications, anchors shall be designed per the requirements of City of Los Angeles information Bulletin P/BC 2023-071.

This supplement expires concurrently with the evaluation report, reissued July 2025.

**DIVISION: 03 00 00—CONCRETE**

Section: 03 16 00—Concrete Anchors

**DIVISION: 05 00 00—METALS**

Section: 05 05 19—Post-Installed Concrete Anchors

**REPORT HOLDER:**

DEWALT

**EVALUATION SUBJECT:****PURE110+® EPOXY ADHESIVE ANCHOR SYSTEM AND POST-INSTALLED REINFORCING BAR CONNECTIONS IN CRACKED AND UNCRACKED CONCRETE (DEWALT)****1.0 REPORT PURPOSE AND SCOPE****Purpose:**

The purpose of this evaluation report supplement is to indicate that the Pure110+ Epoxy Adhesive Anchor System and Post-Installed Reinforcing Bar Connections in Cracked and Uncracked Concrete, described in ICC-ES evaluation report [ESR-3298](#), has also been evaluated for compliance with the codes noted below.

**Applicable code editions:**

- 2023 Florida Building Code—Building
- 2023 Florida Building Code—Residential

**2.0 CONCLUSIONS**

The Pure110+ Epoxy Adhesive Anchor System and Post-Installed Reinforcing Bar Connections in Cracked and Uncracked Concrete, described in Sections 2.0 through 7.0 of the evaluation report [ESR-3298](#), comply with the *Florida Building Code—Building* and the *Florida Building Code—Residential*. The design requirements must be determined in accordance with the *Florida Building Code—Building* or the *Florida Building Code—Residential*, as applicable. The installation requirements noted in ICC-ES evaluation report [ESR-3298](#) for the 2021 *International Building Code*® meet the requirements of the *Florida Building Code—Building* or the *Florida Building Code—Residential*, as applicable.

Use of the Pure110+ epoxy adhesive anchors and Post-Installed Reinforcing Bar Connections has also been found to be in compliance with the High-Velocity Hurricane Zone provisions of the *Florida Building Code—Building* and the *Florida Building Code—Residential* with the following condition:

- a) For connections subject to uplift, the connection must be designed for no less than 700 pounds (3114 N).

For products falling under Florida Rule 61G20-3, verification that the report holder's quality-assurance program is audited by a quality-assurance entity approved by the Florida Building Commission for the type of inspections being conducted is the responsibility of an approved validation entity (or the code official, when the report holder does not possess an approval by the Commission). Florida Rule 61G20-3 is applicable to products and/or systems which comprise the building envelope and structural frame for compliance with the structural requirements of the Florida Building Code.

This supplement expires concurrently with the evaluation report, reissued July 2025