

# ICC-ES Evaluation Report

**ESR-3889**

Reissued November 2025

Revised February 2026

Subject to renewal November 2026



This report also contains:

- [City of LA Supplement](#)

- [FL Supplement w/ HVHZ](#)

ICC-ES Evaluation Reports are not to be construed as representing aesthetics or any other attributes not specifically addressed, nor are they to be construed as an endorsement of the subject of the report or a recommendation for its use. There is no warranty by ICC Evaluation Service, LLC, express or implied, as to any finding or other matter in this report, or as to any product covered by the report.

Copyright © 2026 ICC Evaluation Service, LLC. All rights reserved.

<p><b>DIVISION: 03 00 00— CONCRETE</b></p> <p><b>Section: 03 16 00— Concrete Anchors</b></p> <p><b>DIVISION: 05 00 00— METALS</b></p> <p><b>Section: 05 05 19—Post- Installed Concrete Anchors</b></p>	<p><b>REPORT HOLDER:</b> <b>DEWALT</b></p>  <p><b>ADDITIONAL LISTEE:</b> <b>THE HILLMAN GROUP</b></p>	<p><b>EVALUATION SUBJECT:</b></p> <p><b>SCREW-BOLT+™ ANCHORS AND HANGER MATE®+ ROD HANGER SCREW ANCHORS IN CRACKED AND UNCRACKED CONCRETE (DEWALT)</b></p>	
--	--	--	---

## 1.0 EVALUATION SCOPE

Compliance with the following codes:

- 2024, 2021, 2018, and 2015 [International Building Code® \(IBC\)](#)
- 2024, 2021, 2018, and 2015 [International Residential Code® \(IRC\)](#)

Main references of this report are for the 2024 IBC and IRC. See [Table 8](#) and [Table 9](#) for applicable sections of the code for previous IBC and IRC editions.

Property evaluated:

- Structural

## 2.0 USES

The Screw-Bolt+ anchors and HangerMate+ rod hanger screw anchors are used as anchorage in cracked and uncracked normal-weight concrete and lightweight concrete having a specified compressive strength,  $f'_c$ , of 2,500 psi to 8,500 psi (17.2 MPa to 58.6 MPa) to resist static, wind and seismic tension and shear loads.

The 1/4-inch-, 3/8-inch- and 1/2-inch-diameter (6.4 mm, 9.5 mm and 12.7 mm) Screw-Bolt+ anchors may be installed in the topside of cracked and uncracked normal-weight or sand-lightweight concrete-filled steel deck having a specified compressive strength,  $f'_c$ , of 2,500 psi to 8,500 psi (17.2 MPa to 58.6 MPa).

The 1/4-inch-, 3/8-inch-, 1/2-inch-, 5/8-inch, and 3/4-inch-diameter (6.4 mm, 9.5 mm, 12.7 mm, 15.9 mm and 19.1 mm) Screw-Bolt+ anchors may be installed in the soffit of cracked and uncracked normal-weight or sand-lightweight concrete-filled steel deck having a minimum specified compressive strength,  $f'_c$ , of 3,000 psi (20.7 MPa). The 1/4-inch-, 3/8-inch-, and 1/2-inch-diameter (6.4 mm, 9.5 mm, and 12.7 mm) HangerMate+ anchors may be installed in the soffit of cracked and uncracked normal-weight or sand-lightweight concrete-filled steel deck having a minimum specified compressive strength,  $f'_c$ , of 3,000 psi (20.7 MPa).

The anchors are an alternative to cast-in-place anchors described in Section 1901.3 of the 2024 IBC. The anchors may also be used where an engineered design is submitted in accordance with Section R301.1.3 of the IRC.

### 3.0 DESCRIPTION

#### 3.1 Screw-Bolt+ Anchors:

Screw-Bolt+ screw anchors are comprised of an anchor body with hex washer head or flat head (countersunk) style, in various lengths. Available diameters are 1/4-inch, 3/8-inch, 1/2-inch, 5/8-inch and 3/4-inch (6.4 mm, 9.5 mm, 12.7 mm, 15.9 mm and 19.1 mm). The anchor body and hex washer head or flat head are manufactured from low-carbon steel which is case hardened and have minimum 0.0002-inch (5 µm) zinc plating in accordance with ASTM B633 or minimum 0.0021-inch (53 µm) mechanically galvanized zinc plating in accordance with ASTM B695, Class 55. The Screw-Bolt+ anchor is illustrated in [Figures 1A](#) and [1B](#). Product names for the report holder and for the additional listees are presented in the following table.

COMPANY NAME	PRODUCT NAME
DEWALT	Screw-Bolt+
The Hillman Group	Hillman Screw-Bolt+
	Power Pro Screw-Bolt+

The hex head of the anchor is formed with an integral washer and serrations on the underside. The anchor body is formed with dual lead threads and a chamfered tip. The screw anchors are installed in a predrilled hole with a powered impact wrench or torque wrench. The threads on the anchor tap into the sides of the predrilled hole and interlock with the base material during installation.

#### 3.2 HangerMate+ Anchors:

HangerMate+ rod hanger screw anchors are comprised of the following: a nominally 1/4-inch-diameter one-piece anchor body, with a hex coupler head version containing internal threads that accepts threaded rods and bolts in 1/4-inch and 3/8-inch (6.4 mm and 9.5 mm) diameters; a stud head version containing external threads in 3/8-inch (9.5 mm) diameter; or a nominally 3/8-inch-diameter one-piece anchor body, with a hex coupler head version containing internal threads that accepts threaded rods and bolts in 3/8-inch and 1/2-inch (9.5 mm and 12.7 mm) diameters.

The anchor body and hex coupler head are manufactured from low-carbon steel which is case hardened, and have minimum 0.0002-inch (5 µm) zinc plating in accordance with ASTM B633. The HangerMate+ rod hanger screw anchor is illustrated in [Figures 1A](#) and [1B](#).

Product names for the report holder and for the additional listees are presented in the following table.

COMPANY NAME	PRODUCT NAME
DEWALT	HangerMate+
The Hillman Group	Hillman HangerMate+

The hex coupler head of the anchor is formed with serrations on the underside, and with internal threads into the topside that accepts threaded rods or threaded bolt steel insert elements. The anchor body is formed with dual lead threads and a chamfered tip. The anchors are installed in a predrilled hole with a powered impact wrench or torque wrench. The threads on the anchor body tap into the sides of the predrilled concrete hole and interlock with the base material during installation.

#### 3.3 Threaded Steel Insert Elements for HangerMate+:

Threaded steel insert elements must be threaded into the HangerMate+ anchors to form a connection. The material properties of the steel inserts must comply national or international specifications (e.g., ASTM A36; ASTM A307, ASTM F1554, Grade 36; ASTM A307, SAE J429, Grade 2, ASTM A193, Grade B7), or equivalent.

#### 3.4 Concrete:

Normal-weight and lightweight concrete must conform to Sections 1903 and 1905 of the 2024 IBC.

#### 3.5 Steel Deck Panels:

Steel deck panels for anchors must comply with the configurations in [Figures 5A](#), [5B](#), [6A](#) and [6B](#) of this report, and have a minimum base-metal thickness of 0.035 inch (0.89 mm) [No. 20 gauge]. Steel deck must comply with ASTM A653/A 653M SS Grade 50, and have a minimum yield strength of 50 ksi (345 MPa).

### 4.0 DESIGN AND INSTALLATION

#### 4.1 Strength Design:

**4.1.1 General:** Design strength of anchors complying with the 2024 IBC, as well as Section R301.1.3 of the 2024 IRC must be determined in accordance with ACI 318-19 Chapter 17 and this report.

A design example in accordance with the 2024 IBC is given in [Figure 7](#) of this report.

Design parameters provided in [Tables 3A, 3B, 4, 5](#) and [6](#) of this report are based on the 2024 IBC (ACI 318-19), unless noted otherwise in Section 4.1.1 through 4.1.12 of this report.

The strength design of anchors must comply with ACI 318-19 Section 17.5.1.2, except as required in ACI 318-19 Section 17.10. Strength reduction factors,  $\phi$ , as given in ACI 318-19 Section 17.5.3, and noted in [Tables 3A, 3B, 4, 5](#) and [6](#) of this report, must be used for load combinations calculated in accordance with Section 1605.1 of the 2024 IBC or Section 5.3 of ACI 318-19. The value of  $f'_c$  used in the calculation must be limited to a maximum of 8,000 psi (55.2 MPa), in accordance with ACI 318-19 Section 17.3.1.

**4.1.2 Requirements for Static Steel Strength in Tension,  $N_{sa}$ :** The nominal static steel strength of a single anchor in tension,  $N_{sa}$ , calculated in accordance with ACI 318-19 Section 17.6.1.2, is given in [Table 3](#) of this report. Strength reduction factors,  $\phi$ , corresponding to brittle steel elements must be used.

**4.1.3 Requirements for Static Concrete Breakout Strength in Tension,  $N_{cb}$  or  $N_{cbg}$ :** The nominal concrete breakout strength of a single anchor or a group of anchors in tension,  $N_{cb}$  or  $N_{cbg}$ , respectively, must be calculated in accordance with ACI 318-19 Section 17.6.2, with modifications as described in this section. The basic concrete breakout strength of a single anchor in tension in cracked concrete,  $N_b$ , must be calculated according to ACI 318-19 Section 17.6.2.2, using the values of  $h_{ef}$  and  $k_{cr}$  as given in [Table 3](#) of this report. The nominal concrete breakout strength in tension in regions where analysis indicates no cracking in accordance with ACI 318-19 Section 17.6.2.5.1(a) must be calculated with the value of  $k_{uncr}$  as given in [Tables 3A](#) and [4](#) of this report and with  $\psi_{c,N} = 1.0$ .

For anchors installed in the soffit of sand-lightweight or normal-weight concrete filled steel deck floor and roof assemblies, as shown in [Figures 5A, 5B, 6A](#) and [6B](#), calculation of the concrete breakout strength in accordance with ACI 318-19 Section 17.6.2, is not required.

**4.1.4 Requirements for Static Pullout Strength in Tension,  $N_{pn}$ :** The nominal pullout strength of a single anchor or a group of anchors, in accordance with ACI 318-19 Sections 17.6.3.1 and 17.6.3.2.1 in cracked and uncracked concrete,  $N_{p,cr}$  and  $N_{p,uncr}$ , respectively, is given in [Tables 3A](#) and [4](#). In lieu of ACI 318-19 Section 17.6.3.3,  $\psi_{c,P} = 1.0$  for all design cases. The nominal pullout strength in cracked concrete may be adjusted by calculation according to Eq-1:

$$N_{pn,f'_c} = N_{p,cr} \left( \frac{f'_c}{2,500} \right)^n \quad (\text{lb, psi}) \quad (\text{Eq-1})$$

$$N_{pn,f'_c} = N_{p,cr} \left( \frac{f'_c}{17.2} \right)^n \quad (\text{N, MPa})$$

where  $f'_c$  is the specified concrete compressive strength and  $n$  is the factor defining the influence of concrete compressive strength on pullout strength. For the nominal  $1/4$ -inch-diameter anchors (i.e.  $1/4$ -inch-diameter anchor bodies),  $n$  is 0.3, and for the  $3/4$ -inch-diameter anchors with  $h_{nom} = 7/4$ -inch,  $n$  is 0.35. For all other cases,  $n$  is 0.5.

In regions where analysis indicates no cracking in accordance with ACI 318-19 Section 17.6.3.3, the nominal pullout strength in tension of the anchors can be adjusted by calculation according to Eq-2:

$$N_{pn,f'_c} = N_{p,uncr} \left( \frac{f'_c}{2,500} \right)^n \quad (\text{lb, psi}) \quad (\text{Eq-2})$$

$$N_{pn,f'_c} = N_{p,uncr} \left( \frac{f'_c}{17.2} \right)^n \quad (\text{N, MPa})$$

where  $f'_c$  is the specified concrete compressive strength and  $n$  is the factor defining the influence of concrete compressive strength on pullout strength. For the  $1/4$ -inch-diameter anchors,  $n$  is 0.3, and for the  $3/4$ -inch-diameter anchors with  $7/4$ -inch embedment,  $n$  is 0.35. For all other cases,  $n$  is 0.5.

Where values for  $N_{p,cr}$  or  $N_{p,uncr}$  are not provided in [Tables 3A](#) and [4](#) of this report, the pullout strength in tension need not be considered or evaluated.

The nominal pullout strength in tension of anchors installed in the upper and lower flute soffit of sand-lightweight or normal-weight concrete-filled steel deck floor and roof assemblies, as shown in [Figures 5A, 5B, 6A](#) and [6B](#), is provided in [Tables 5](#) and [6](#). The nominal pullout strength in cracked concrete can be adjusted by calculation according to Eq-1, whereby the value of  $N_{p,deck,cr}$  must be substituted for  $N_{p,cr}$  and the value of 3,000 psi (20.7 MPa) must be substituted for the value of 2,500 psi (17.2 MPa) in the denominator. The nominal pullout strength in uncracked concrete can be adjusted by calculation according to Eq-2, whereby the value of  $N_{p,deck,uncr}$  must be substituted for  $N_{p,uncr}$  and the value of 3,000 psi (20.7 MPa) must be substituted for the value of 2,500 psi (17.2 MPa) in the denominator.

**4.1.5 Requirements for Static Steel Strength in Shear,  $V_{sa}$ :** The nominal steel strength in shear,  $V_{sa}$ , of a single anchor in accordance with ACI 318-19 Section 17.7.1.2 is given in [Tables 3B](#) and [4](#) of this report and must be used in lieu of the values derived by calculation from ACI 318-19 Eq. 17.7.1.2b. Strength reduction factors,  $\phi$ , corresponding to brittle steel elements must be used.

The nominal shear strength of anchors installed in the soffit of sand-lightweight or normal-weight concrete-filled steel deck floor and roof assemblies,  $V_{sa,deck}$ , as shown in [Figures 5A, 5B, 6A](#) and [6B](#) is given in [Tables 5](#) and [6](#) of this report, in lieu of the values derived by calculation from ACI 318-19 Eq. 17.7.1.2b.

**4.1.6 Requirements for Static Concrete Breakout Strength in Shear,  $V_{cb}$  or  $V_{cbg}$ :** The nominal concrete breakout strength of a single anchor or group of anchors in shear,  $V_{cb}$  or  $V_{cbg}$ , respectively, must be calculated in accordance with ACI 318-19 Section 17.7.2, with modifications as described in this section. The basic concrete breakout strength of a single anchor in shear,  $V_b$ , must be calculated in accordance with ACI 318-19 Section 17.7.2.2.1, using the value of  $\ell_e$  and  $d_a$  given in [Tables 3B](#) and [4](#) of this report.

For anchors installed in the topside of concrete-filled steel deck assemblies, the nominal concrete breakout strength of a single anchor or group of anchors in shear,  $V_{cb}$  or  $V_{cbg}$ , respectively, must be calculated in accordance with ACI 318-19 Section 17.7.2, using the actual member topping thickness,  $h_{min,deck}$ , in the determination of  $A_{vc}$ . Minimum member topping thickness for anchors in the topside of concrete-filled steel deck assemblies is given in [Tables 1A, 1B](#) and [2](#) of this report, as applicable.

For anchors installed in the soffit of sand-lightweight or normal-weight concrete filled steel deck floor and roof assemblies, as shown in [Figures 5A, 5B, 6A](#) and [6B](#), calculation of the concrete breakout strength in accordance with ACI 318-19 Section 17.7.2 is not required.

**4.1.7 Requirements for Static Concrete Pryout Strength in Shear,  $V_{cp}$  or  $V_{cpg}$ :** The nominal concrete pryout strength of a single anchor or group of anchors,  $V_{cp}$  or  $V_{cpg}$ , respectively, must be calculated in accordance with ACI 318-19 Section 17.7.3, using the value of  $k_{cp}$  provided in [Tables 3B](#) and [4](#), and the value of  $N_{cb}$  or  $N_{cbg}$  as calculated in Section 4.1.3 of this report.

For anchors installed in the soffit of sand-lightweight or normal-weight concrete filled steel deck floor and roof assemblies, as shown in [Figures 5A, 5B, 6A](#) and [6B](#), calculation of the concrete pryout strength in accordance with ACI 318-19 Section 17.7.3 is not required.

#### **4.1.8 Requirements for Seismic Design:**

**4.1.8.1 General:** For load combinations including seismic loads, the design must be performed in accordance with ACI 318-19 Section 17.10. Modifications to ACI 318-19 Section 17.10 must be applied under 2024 IBC Section 1905.7.

The nominal steel strength and nominal concrete breakout strength for anchors in tension, and the nominal concrete breakout strength and pryout strength for anchors in shear, must be calculated according to ACI 318-19 Sections 17.6 and 17.7, taking into account the corresponding values in [Tables 3A, 3B](#) and [4](#) of this report.

The anchors comply with ACI 318-19 Section 2.3 as brittle steel elements and must be designed in accordance with ACI 318-19 Sections 17.10.4, 17.10.5, 17.10.6, and 17.10.7.

The 1/4-inch-diameter (6.4 mm), 3/8-inch-diameter (9.5 mm), 1/2-inch-diameter (12.7 mm), 5/8-inch-diameter (15.9 mm) and 3/4-inch-diameter (19.1 mm) Screw-Bolt+ anchors and the 1/4-inch-diameter (6.4 mm), 3/8-inch-diameter (9.5 mm) and 1/2-inch-diameter (12.7 mm) HangerMate+ anchors may be installed in regions designated as IBC Seismic Design Categories A through F.

**4.1.8.2 Seismic Tension:** The nominal steel strength and nominal concrete breakout strength for anchors in tension must be calculated according to ACI 318-19 Sections 17.6.1 and 17.6.2, as described in Sections 4.1.2 and 4.1.3 of this report. In accordance with ACI 318-19 Section 17.6.3.2.1, the appropriate value for nominal pullout strength in tension for seismic loads,  $N_{p,eq}$  described in [Table 3](#) of this report, must be used in lieu of  $N_p$ .  $N_{p,eq}$  may be adjusted by calculations for concrete compressive strength in accordance with Eq-1 of this report.

Where values for  $N_{p,eq}$  are not provided in [Tables 3A](#) and [4](#), the pullout strength in tension for seismic forces need not be evaluated.

For anchors installed in the soffit of sand-lightweight or normal-weight concrete-filled steel deck floor and roof assemblies, the nominal pullout strength in tension for seismic loads,  $N_{p,deck,eq}$ , is provided in [Tables 5](#) and [6](#) and must be used in lieu of  $N_{p,cr}$ .  $N_{p,deck,eq}$  may be adjusted by calculations for concrete compressive strength in accordance with Eq-1 of this report where the value of 3,000 psi or 20.7 MPa must be substituted for the value of 2,500 psi or 17.2 MPa in the denominator.

**4.1.8.3 Seismic Shear:** The nominal concrete breakout strength and pryout strength for anchors in shear must be calculated according to ACI 318-19 Sections 17.7.2 and 17.7.3, as described in Sections 4.1.6 and 4.1.7 of this report. In accordance with ACI 318-19 Section 17.7.1.2, the appropriate value for nominal steel strength in shear for seismic loads,  $V_{sa,eq}$ , described in [Tables 3B](#) and [4](#) of this report, must be used in lieu of  $V_{sa}$ .

For anchors installed in the soffit of sand-lightweight or normal-weight concrete-filled steel deck floor and roof assemblies, as shown in [Figures 5A](#), [5B](#), [6A](#) and [6B](#), the appropriate value for nominal steel strength in shear for seismic loads,  $V_{sa,eq}$ , described in [Tables 5](#) and [6](#), must be used in lieu of  $V_{sa}$ .

**4.1.9 Requirements for Interaction of Tensile and Shear Forces:** The effects of combined tensile and shear forces must be determined in accordance with ACI 318-19 Section 17.8.

**4.1.10 Requirements for Critical Edge Distance,  $c_{ac}$ :** In applications where  $c < c_{ac}$  and supplemental reinforcement to control splitting of the concrete is not present, the concrete breakout strength in tension for uncracked concrete, calculated according to ACI 318-19 Section 17.6.2 must be further multiplied by the factor  $\psi_{cp,N}$  given by Eq-3:

$$\psi_{cp,N} = \frac{c}{c_{ac}} \quad (\text{Eq-3})$$

whereby the factor  $\psi_{cp,N}$  need not be taken less than  $\frac{1.5h_{ef}}{c_{ac}}$ . For all other cases,  $\psi_{cp,N} = 1.0$ . In lieu of using ACI 318-19 Section 17.9.5, values of  $c_{ac}$  provided in [Tables 3A](#) and [4](#) of this report must be used.

**4.1.11 Requirements for Minimum Member Thickness, Minimum Anchor Spacing and Minimum Edge Distance:** In lieu of ACI 318-19 Section 17.9.2, the values of  $s_{min}$  and  $c_{min}$  as given in [Table 1](#) of this report must be used. In lieu of ACI 318-19 Section 17.9.4, minimum member thicknesses,  $h_{min}$ , as given in [Tables 1A](#) and [1B](#) of this report must be used.

For anchors installed in the topside of concrete-filled steel deck assemblies, the anchors must be installed in accordance with [Tables 1A](#), [1B](#) and [2](#) and [Figure 4](#) of this report.

For anchors installed through the soffit of steel deck assemblies, the anchors must be installed in accordance with [Figures 5A](#), [5B](#), [6A](#), and [6B](#), and must have an axial spacing along the flute equal to the greater of  $3h_{ef}$  or 1.5 times the flute width.

**4.1.12 Requirements for Lightweight Concrete:** For the use of anchors in lightweight concrete, the modification factor  $\lambda_a$  equal to  $0.8\lambda$  is applied to all values of  $\sqrt{f'_c}$  affecting  $N_n$  and  $V_n$ .

The value of  $\lambda$  must be determined in accordance with ACI 318-19.

For anchors installed in the soffit of sand-lightweight concrete-filled steel deck and floor and roof assemblies, further reduction of the pullout values provided in this report is not required.

## 4.2 Allowable Stress Design (ASD):

**4.2.1 General:** Design values for use with allowable stress design load combinations calculated in accordance with Section 1605.1 of the 2024 IBC must be established using Eq-4 and Eq-5 as follows:

$$T_{allowable,ASD} = \frac{\phi N_n}{\alpha} \quad (\text{Eq-4})$$

$$V_{allowable,ASD} = \frac{\phi V_n}{\alpha} \quad (\text{Eq-5})$$

where:

$$T_{allowable,ASD} = \text{Allowable tension load (lbf or kN)}$$

$$V_{allowable,ASD} = \text{Allowable shear load (lbf or kN)}$$

$\phi N_n$  = Lowest design strength of an anchor or anchor group in tension as determined in accordance with ACI 318-19 Chapter 17 and 2024 IBC Section 1905.7, and Section 4.1 of this report, as applicable (lbf or kN).

$\phi V_n$  = Lowest design strength of an anchor or anchor group in shear as determined in accordance with ACI 318-19 Chapter 17 and 2024 IBC Section 1905.7, and Section 4.1 of this report, as applicable (lbf or kN).

$\alpha$  = Conversion factor calculated as a weighted average of the load factors for the controlling load combination. In addition,  $\alpha$  must include all applicable factors to account for non-ductile failure modes and required over-strength.

The limits on edge distance, anchor spacing and member thickness as given in [Tables 1A, 1B](#) and [2](#) of this report must apply. An example of Allowable Stress Design tension values for illustrative purposes is shown in [Table 7](#) of this report.

**4.2.2 Interaction of Tensile and Shear Forces:** The interaction must be calculated and consistent with ACI 318-19 Section 17.8, as follows:

For shear loads  $V \leq 0.2V_{allowable,ASD}$ , the full allowable load in tension  $T_{allowable,ASD}$  must be permitted.

For tension loads  $T \leq 0.2T_{allowable,ASD}$ , the full allowable load in shear  $V_{allowable,ASD}$  must be permitted.

For all other cases:  $\frac{T}{T_{allowable}} + \frac{V}{V_{allowable}} \leq 1.2$  (Eq-6)

#### 4.3 Installation:

Installation parameters are provided in [Tables 1A, 1B](#) and [2](#), and [Figures 1A, 2](#) and [3](#) of this report. Anchor locations must comply with this report and plans and specifications approved by the code official. The Screw-Bolt+ and HangerMate+ screw anchors must be installed according to the manufacturer's published installation instructions and this report. Anchors must be installed in holes drilled using carbide-tipped masonry drill bits complying with ANSI B212.15.

The Screw-Bolt+ and HangerMate+ screw anchors are permitted to be loosened by a maximum of one full turn and retightened with a torque wrench or powered impact wrench to facilitate fixture attachment or realignment. Complete removal and reinstallation of the anchor is not allowed.

For anchor installation in the topside of concrete-filled steel deck assemblies, installation must comply with [Tables 1A, 1B](#) and [2](#) and [Figure 4](#), as applicable.

For installation in the soffit of concrete on steel deck assemblies, the hole diameter in the steel deck must not exceed the diameter of the hole in the concrete by more than  $\frac{1}{8}$  inch (3.2 mm). For member thickness and edge distance restrictions for installations into the soffit of concrete on steel deck assemblies, see [Tables 5](#) and [6](#) and [Figures 5A, 5B, 6A](#) and [6B](#).

#### 4.4 Special Inspection:

Periodic special inspection is required, in accordance with Section 1705.1.1 and Table 1705.3 of the 2024 IBC. The special inspector must make periodic inspections during anchor installation to verify anchor type, anchor dimensions, concrete type, concrete compressive strength, hole dimensions, drill bit size and type, anchor spacing, edge distances, concrete thickness, anchor embedment, maximum impact wrench power and adherence to the manufacturer's published installation instructions. The special inspector must be present as often as required in accordance with the "statement of special inspection."

## 5.0 CONDITIONS OF USE:

The Screw-Bolt+ and HangerMate+ screw anchors described in this report comply with, or are a suitable alternative to what is specified in, those codes listed in Section 1.0 of this report, subject to the following conditions:

- 5.1 The anchors must be installed in accordance with the manufacturer's published installation instructions and this report. In case of a conflict, this report governs.
- 5.2 Anchor sizes, dimensions, and minimum embedment depths are as set forth in this report.
- 5.3 The 1/4-inch to 3/4-inch (6.4 mm to 19.1 mm) Screw-Bolt+ anchors and 1/4-inch- to 1/2-inch-diameter (6.4 mm to 12.7 mm) HangerMate+ anchors must be installed in cracked and uncracked normal-weight concrete and lightweight concrete having a specified compressive strength,  $f'_c$ , of 2,500 psi to 8,500 psi (17.2 MPa to 58.6 MPa).
- 5.4 The 1/4-inch to 1/2-inch (6.4 mm to 12.7 mm) Screw-Bolt+ anchors may be installed in the topside of cracked and uncracked normal-weight or sand-lightweight concrete-filled steel deck having a minimum specified compressive strength,  $f'_c$ , of 2,500 psi to 8,500 psi (17.2 MPa to 58.6 MPa).
- 5.5 The 1/4-inch to 3/4-inch (6.4 mm to 19.1 mm) Screw-Bolt+ anchors and 1/4-inch- to 1/2-inch-diameter (6.4 mm to 12.7 mm) HangerMate+ anchors must be installed in the soffit of cracked and uncracked normal-weight or sand-lightweight concrete-filled steel deck having a minimum specified compressive strength,  $f'_c$ , of 3,000 psi (20.7 MPa).
- 5.6 The values of  $f'_c$  used for calculation purposes must not exceed 8,000 psi (55.2 MPa).
- 5.7 The concrete must have attained its minimum design strength prior to installation of the anchors.
- 5.8 Strength design values must be established in accordance with Section 4.1 of this report.
- 5.9 Allowable design values must be established in accordance with Section 4.2 of this report.

- 5.10** Anchor spacing(s) and edge distance(s), and minimum member thickness, must comply with [Tables 1A, 1B and 2](#), and [Figures 4, 5A, 5B, 6A, and 6B](#) of this report.
- 5.11** For anchors with a 1/4-inch-diameter screw anchor body, installations using a manual torque wrench are limited to a maximum concrete compressive strength of 4,000 psi (27.6 MPa).
- 5.12** Reported values for the HangerMate+ with an internally threaded head do not consider the steel insert element which must be verified by the design professional. Shear design values in this report for the HangerMate+ with an internally threaded head are for threaded rod or steel inserts with an ultimate strength,  $F_u \geq 125$  ksi; threaded rod or steel inserts with an  $F_u$  less than 125 ksi are allowed provided the steel strength shear values are multiplied by the ratio of  $F_u$  (ksi) of the steel insert and 125 ksi.
- 5.13** Prior to installation, calculations and details demonstrating compliance with this report must be submitted to the code official. The calculations and details must be prepared by a registered design professional where required by the statutes of the jurisdiction in which the project is to be constructed.
- 5.14** Since an ICC-ES acceptance criteria for evaluating data to determine the performance of anchors subjected to fatigue or shock loading is unavailable at this time, the use of these anchors under such conditions is beyond the scope of this report.
- 5.15** The 1/4-inch- to 3/4-inch-diameter (6.4 mm to 19.1 mm) Screw-Bolt+ anchors and 1/4-inch- to 1/2-inch-diameter (6.4 mm to 12.7 mm) HangerMate+ anchors may be installed in regions of concrete where cracking has occurred or where analysis indicates cracking may occur ( $f_t > f_r$ ), subject to the conditions of this report.
- 5.16** The 1/4-inch- to 3/4-inch-diameter (6.4 mm to 19.1 mm) Screw-Bolt+ anchors and 1/4-inch- to 1/2-inch-diameter (6.4 mm to 12.7 mm) HangerMate+ anchors may be used to resist short-term loading due to wind or seismic forces (Seismic Design Categories A through F under the IBC), subject to the conditions of this report.
- 5.17** Anchors are not permitted to support fire-resistance-rated construction. Where not otherwise prohibited by code, Screw-Bolt+ and HangerMate+ anchors are permitted for installation in fire-resistance-rated construction provided that at least one of the following conditions is fulfilled:
- Anchors are used to resist wind or seismic forces only.
  - Anchors that support a fire-resistance-rated envelope or a fire-resistance-rated membrane, are protected by approved fire-resistance-rated materials, or have been evaluated for resistance to fire exposure in accordance with recognized standards.
  - Anchors are used to support nonstructural elements.
- 5.18** Anchors have been evaluated for reliability against brittle failure and found to be not significantly sensitive to stress-induced hydrogen embrittlement.
- 5.19** Use of carbon steel anchors with zinc plating in accordance with ASTM B633 as described in Section 3.1 and 3.2 of this report is limited to dry, interior locations.
- 5.20** Steel anchoring materials in contact with preservative-treated and fire-retardant-treated wood must be zinc-coated. Minimum coating weights for zinc-coated steel anchors must comply with ASTM B695, Class 55 (mechanically galvanized zinc plating) as described in Section 3.1 of this report.
- 5.21** Use of carbon steel anchors with mechanically galvanized zinc plating in accordance with ASTM B695, Class 55 as described in Section 3.1 of this report is permitted for exterior exposure or damp environments.
- 5.22** Special inspection must be provided in accordance with Section 4.4.
- 5.23** Screw-Bolt+ and HangerMate+ are manufactured under an approved quality control program with inspections by ICC-ES.

## 6.0 EVIDENCE SUBMITTED

- 6.1** Data in accordance with the [ICC-ES Acceptance Criteria for Mechanical Anchors in Concrete Elements AC193 \(24\)](#), published April 2025.
- 6.2** Quality control documentation.

## 7.0 IDENTIFICATION





- 7.1** The ICC-ES mark of conformity, electronic labeling, or the evaluation report number (ICC-ES ESR-3889) along with the name, registered trademark, or registered logo of the report holder and/or listee must be included in the product label.
- 7.2** In addition, the Screw-Bolt+ and HangerMate+ screw anchors are identified in the field by dimensional characteristics and packaging. A diameter and length marking is stamped on the head of each Screw-Bolt+ anchor; these are visible after installation for verification. Packages are identified with the company name as set forth in Section 3.1 of this report; anchor name; part number; type; and anchor size and length.

7.3 The report holder’s contact information is the following:

**DEWALT**  
**701 EAST JOPPA ROAD**  
**TOWSON, MARYLAND 21286**  
**(800) 524-3244**  
[www.DEWALT.com](http://www.DEWALT.com)  
[anchors@DEWALT.com](mailto:anchors@DEWALT.com)

7.4 The additional listee’s contact information is the following:

**THE HILLMAN GROUP**  
**1280 KEMPER MEADOW DRIVE**  
**CINCINNATI, OHIO 45240**  
[info@hillmangroup.com](mailto:info@hillmangroup.com)

DeWALT Dust Removal Drilling System with HEPA Dust Extractor Options		
Tool	Accessories and Shrouds	Dust Extractor
<b>SDS-Max Drills</b>		
 Cordless   Corded	 SDS-Max Hollow Drill Bits	 Dust Extractor
	 SDS-Max Drill Bits With Shroud	
<b>SDS-Plus Drills</b>		
 Cordless   Corded	 SDS-Plus Drill Bits  SDS-Plus Stop Drill Bits	 Cordless On-board Dust Extractor
	 SDS-Plus Hollow Drill Bits   SDS-Plus Drill Bits With Telescope  SDS-Plus Drill Bits With Suction Tube   SDS-Plus Drill Bits With Shroud  SDS-Plus Stop Drill Bits With Shroud	 Dust Extractor

The DEWALT drilling systems shown collect and remove dust with a HEPA dust extractor during the hole drilling operation in dry base materials using hammer-drill (see step 1 of the manufacturer’s printed installation instructions).

FIGURE A—EXAMPLES OF DEWALT DUST REMOVAL DRILLING SYSTEMS WITH HEPA DUST EXTRACTORS FOR ILLUSTRATION

TABLE A—INSTALLATION AND DESIGN INDEX<sup>1</sup>

Product Name	Installation Specifications	Tension Design Data			Shear Design Data		
		Concrete	Top of Steel Deck	Steel Deck Soffit	Concrete	Top of Steel Deck	Steel Deck Soffit
Screw-Bolt+	Tables 1A, 2 and 5	Table 3A	Table 3A	Table 5	Table 3B	Table 3B	Table 5
HangerMate+	Tables 1B and 6	Table 4	Table 4	Table 6	Table 4	Table 4	Table 6

Concrete Type	Concrete State	Anchor Nominal Size	Seismic Design Categories <sup>2</sup>
Normal-weight and lightweight	Cracked	1/4", 3/8", 1/2", 5/8", 3/4"	A through F
	Uncracked	1/4", 3/8", 1/2", 5/8", 3/4"	A and B

For SI: 1 inch = 25.4 mm. For pound-inch units: 1 mm = 0.03937 inch.

<sup>1</sup>Reference ACI 318-19 Section 17.5.1.3. The controlling strength is decisive from all appropriate failure modes, as applicable (i.e. steel, concrete breakout, pullout, pryout) and design assumptions.

<sup>2</sup>See Section 4.1.8 for requirements for seismic design, where applicable.

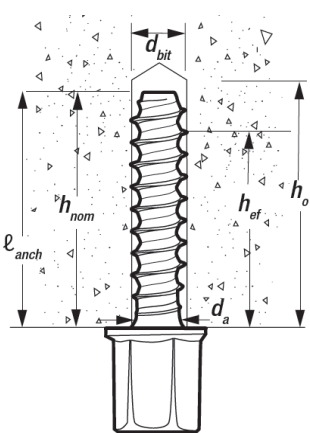
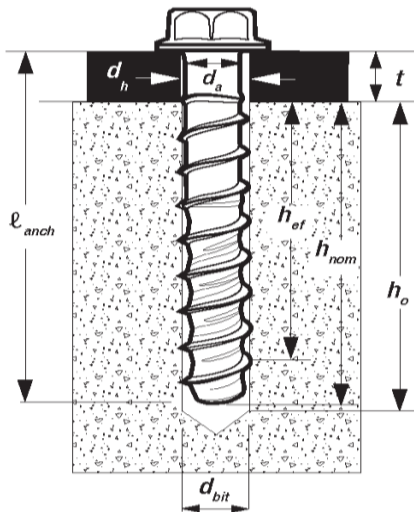

FIGURE 1B—SCREW-BOLT+ (Hex Head and Flat Head Versions) AND HANGERMATE+ (Bottom Pictures – Internally Threaded Head and External Thread Head Rod Hanger Versions)

FIGURE 1A—SCREW-BOLT+ ANCHOR DETAIL (Left Picture) AND HANGERMATE+ ANCHOR DETAIL (Right Picture)

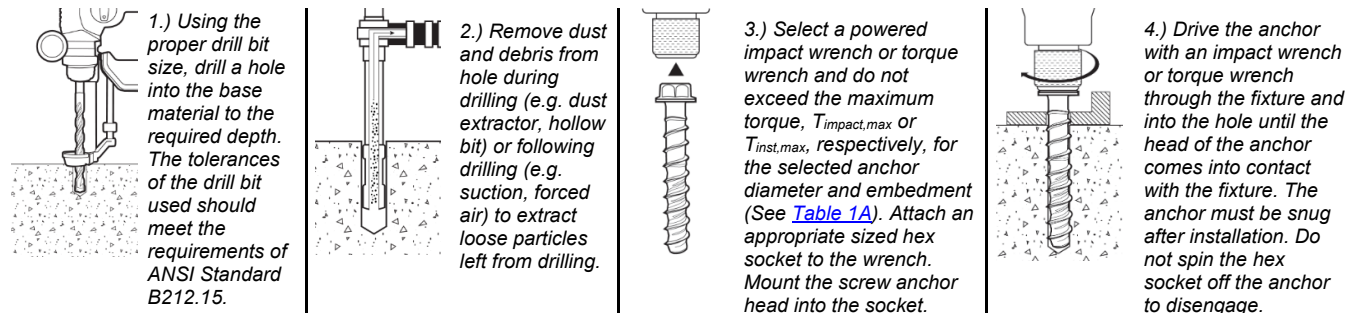

FIGURE 2—SCREW-BOLT+ INSTALLATION INSTRUCTIONS (Hex Head Version Illustrated, Flat Head Version is Not Shown)

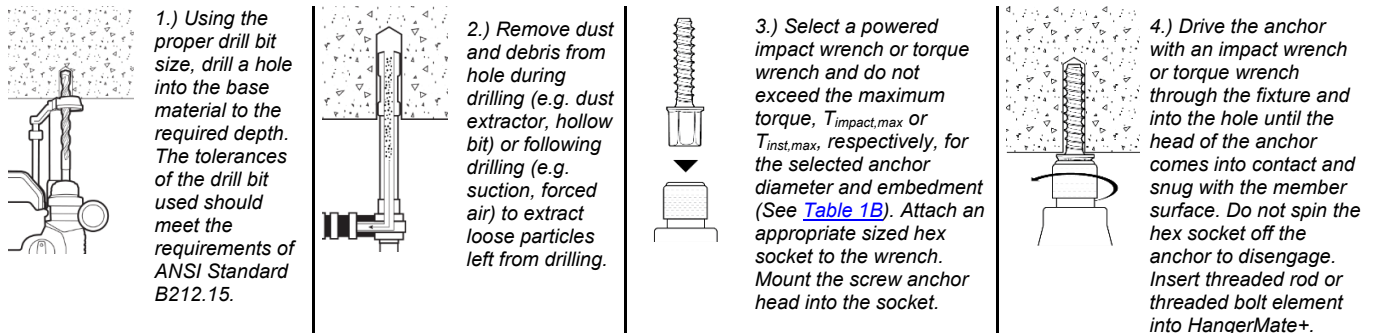

FIGURE 3—HANGERMATE+ INSTALLATION INSTRUCTIONS (Internally Threaded Rod Hanger Version Illustrated, External Thread Hanger Not Shown)

TABLE 1A—SCREW-BOLT+ ANCHOR INSTALLATION AND SUPPLEMENTAL INFORMATION<sup>1,2,3</sup>

Anchor Property / Setting Information	Notation	Units	Nominal Anchor Size (inch)																		
			1/4			3/8			1/2			5/8			3/4						
Head style	-	-	Hex or Flat Head			Hex or Flat Head			Hex or Flat Head			Hex Head			Hex Head						
Nominal anchor diameter	$d_a$	in. (mm)	0.250 (6.4)			0.375 (9.5)			0.500 (12.7)			0.625 (15.9)			0.750 (19.1)						
Minimum diameter of fixture hole clearance <sup>5</sup>	$d_h$	in. (mm)	1 <sup>1</sup> / <sub>32</sub> (8.7)			1/2 (12.7)			5/8 (15.9)			3/4 (19.1)			7/8 (22.2)						
Nominal drill bit diameter (ANSI)	$d_{bit}$	in.	1/4			3/8			1/2			5/8			3/4						
Minimum nominal embedment depth <sup>6</sup>	$h_{nom}$	in. (mm)	1 <sup>5</sup> / <sub>8</sub> (41)	2 (51)	2 <sup>1</sup> / <sub>2</sub> (64)	2 (51)	2 <sup>1</sup> / <sub>2</sub> (64)	3 <sup>1</sup> / <sub>4</sub> (83)	2 <sup>1</sup> / <sub>2</sub> (64)	3 (76)	3 <sup>1</sup> / <sub>2</sub> (89)	4 <sup>1</sup> / <sub>4</sub> (108)	3 <sup>1</sup> / <sub>4</sub> (83)	3 <sup>5</sup> / <sub>8</sub> (92)	4 (102)	4 <sup>1</sup> / <sub>2</sub> (114)	5 (127)	4 <sup>1</sup> / <sub>4</sub> (108)	5 <sup>1</sup> / <sub>4</sub> (133)	6 <sup>1</sup> / <sub>4</sub> (159)	7 <sup>1</sup> / <sub>4</sub> (184)
Effective embedment	$h_{ef}$	in. (mm)	1.20 (30)	1.52 (39)	1.94 (49)	1.33 (33)	1.75 (44)	2.39 (60)	1.75 (44)	2.17 (55)	2.60 (66)	3.23 (82)	2.24 (56)	2.56 (65)	2.88 (73)	3.30 (84)	3.73 (94)	3.08 (78)	3.93 (100)	4.78 (121)	5.63 (143)
Minimum hole depth	$h_o$	in. (mm)	2 (51)	2 <sup>3</sup> / <sub>8</sub> (60)	2 <sup>7</sup> / <sub>8</sub> (73)	2 <sup>3</sup> / <sub>8</sub> (60)	2 <sup>7</sup> / <sub>8</sub> (73)	3 <sup>5</sup> / <sub>8</sub> (92)	2 <sup>7</sup> / <sub>8</sub> (73)	3 <sup>3</sup> / <sub>8</sub> (86)	3 <sup>7</sup> / <sub>8</sub> (98)	4 <sup>5</sup> / <sub>8</sub> (117)	3 <sup>5</sup> / <sub>8</sub> (86)	4 (102)	4 <sup>3</sup> / <sub>8</sub> (111)	4 <sup>7</sup> / <sub>8</sub> (124)	5 <sup>3</sup> / <sub>8</sub> (137)	4 <sup>5</sup> / <sub>8</sub> (117)	5 <sup>5</sup> / <sub>8</sub> (143)	6 <sup>5</sup> / <sub>8</sub> (168)	7 <sup>5</sup> / <sub>8</sub> (194)
Minimum concrete member thickness	$h_{min}$	in. (mm)	3 <sup>1</sup> / <sub>4</sub> (83)	3 <sup>3</sup> / <sub>4</sub> (95)	4 (102)	3 <sup>1</sup> / <sub>2</sub> (89)	4 (102)	5 (127)	4 <sup>1</sup> / <sub>2</sub> (114)	5 <sup>1</sup> / <sub>4</sub> (133)	6 (152)	6 <sup>3</sup> / <sub>4</sub> (171)	5 (127)	5 <sup>1</sup> / <sub>2</sub> (140)	6 (152)	6 <sup>1</sup> / <sub>2</sub> (165)	7 (178)	6 (152)	7 <sup>1</sup> / <sub>2</sub> (191)	9 (229)	11 <sup>1</sup> / <sub>2</sub> (292)
Minimum edge distance <sup>7</sup>	$c_{min}$	in. (mm)	1 <sup>1</sup> / <sub>2</sub> (38)			$c_{min} = 1\frac{1}{2}$ (38) for $s_{min} \geq 3$ (76);			1 <sup>3</sup> / <sub>4</sub> (44)			1 <sup>3</sup> / <sub>4</sub> (44)			1 <sup>3</sup> / <sub>4</sub> (44)						
Minimum spacing distance <sup>7</sup>	$s_{min}$	in. (mm)	1 <sup>1</sup> / <sub>2</sub> (38)			$s_{min} = 2$ (51) for $c_{min} \geq 2$ (51)			2 <sup>3</sup> / <sub>4</sub> (70)			2 <sup>3</sup> / <sub>4</sub> (70)			3 (76)						
Minimum nominal anchor length <sup>8,9</sup>	$\ell_{anch}$	in.	1 <sup>3</sup> / <sub>4</sub>	2 <sup>1</sup> / <sub>4</sub>	2 <sup>5</sup> / <sub>8</sub>	2 <sup>1</sup> / <sub>2</sub>	3	4	3	4	5	4	5	6	5	6	8				
Maximum impact wrench power (torque)	$T_{impact,max}$	ft.-lb. (N-m)	150 (203)			300 (407)			300 (407)			700 (949)			700 (949)						
Maximum manual installation torque	$T_{inst,max}$	ft.-lb. (N-m)	19 <sup>(4)</sup> (26)	25 <sup>(4)</sup> (34)		25 (34)	40 (54)		45 (61)	60 (81)		60 (81)		60 (81)		70 (81)	90 (123)				
Hex Head	Wrench socket size	-	7/16			9/16			3/4			15/16			1 1/8						
	Max. head height	-	2 1/64			3/8			3 1/64			3 7/64			4 3/64						
	Max. washer dia.	-	3 7/64			3/4			1 1/16			1 1/8			1 13/32						
Flat Head	Driver size	-	T-30			T-50			T-55			N/A			N/A						
	Max head diameter	-	1 7/32			5 7/64			1			N/A			N/A						
	Countersunk angle	-	82			82			82			N/A			N/A						
Effective tensile stress area (screw anchor body)	$A_{se}$	in. <sup>2</sup> (mm <sup>2</sup> )	0.045 (28.8)			0.094 (60.7)			0.176 (113.9)			0.274 (177.0)			0.399 (257.2)						
Minimum specified ultimate strength	$f_{uta}$	psi (N/mm <sup>2</sup> )	100,000 (690)			105,000 (724)			115,000 (793)			95,000 (658)			95,000 (658)						
Minimum specified yield strength	$f_{ya}$	psi (N/mm <sup>2</sup> )	80,000 (552)			84,000 (579)			92,000 (634)			76,000 (524)			76,000 (524)						
Mean axial stiffness <sup>10</sup>	Uncracked concrete	$\beta_{uncr}$	lbf/in. 1,252,000			1,157,000			1,014,000			919,000			715,000						
	Cracked concrete	$\beta_{cr}$	lbf/in. 355,000			330,000			349,000			378,000			337,000						

For SI: 1 inch = 25.4 mm, 1 ft-lb = 1.356 N-m, 1 psi = 0.0069 N/mm<sup>2</sup> (MPa). N/A = Not applicable.

<sup>1</sup>The information presented in this table is to be used in conjunction with the design criteria of ACI 318-19 Chapter 17.

<sup>2</sup>For installations in the topside of concrete-filled steel deck assemblies with minimum concrete member thickness,  $h_{min,deck}$ , of 2.5 inches above the upper flute (topping thickness), see Table 2 and the installation detail in Figure 4 of this report.

<sup>3</sup>For installations through the soffit of steel deck assemblies into concrete, see the installation detail in Figures 5A and 5B of this report.

<sup>4</sup>Installation with 1/4-inch-diameter anchors using a manual torque wrench is limited to a maximum concrete compressive strength of 4,000 psi (27.6 MPa). For installations into lightweight concrete with a nominal embedment depth of 1 5/8-inch, the maximum manual installation torque,  $T_{inst,max}$ , is 18 ft.-lb, as applicable.

<sup>5</sup>The minimum diameter of fixture hole clearance is for the body of the anchor to pass through structural steel members; clearance holes may be 1/8-inch less than tabulated values (same as nominal drill bit diameter) provided the screw anchors are installed through light gauge cold-formed steel members or wood members.

<sup>6</sup>The embedment depth,  $h_{nom}$ , is measured from the outside surface of the concrete member to the embedded end of the anchor.

<sup>7</sup>Additional combinations for minimum edge distance,  $c_{min}$ , and minimum spacing distance,  $s_{min}$ , may be derived by linear interpolation between the given boundary values for the 3/8-inch-diameter anchors.

<sup>8</sup>The listed minimum anchor length is based on the anchor sizes commercially available at the time of publication compared with the requirements to achieve the minimum nominal embedment depth, including consideration of a fixture attachment. Longer length anchors may be selected for larger fixture thickness requirements, see Figure 1A. The minimum nominal length for hex head anchors is measured from under the head to the tip of the anchor, the minimum nominal length for flat head anchors is measured from the top of the head to the tip of the anchor.

<sup>9</sup>Hex head anchors with the following minimum lengths are also suitable for use with cold-formed steel members provided the nominal thickness of the fixture attachment does not exceed 20 gauge (0.036-inch base metal thickness):

For 3/8-inch-diameter anchors with 2 1/2-inch nominal embedment, 2 1/2-inch long anchors.

For 1/2-inch-diameter anchors with 2 1/2-inch nominal embedment, 2 1/2-inch long anchors.

For 1/2-inch-diameter anchors with 3-inch nominal embedment, 3-inch long anchors.

For 5/8-inch-diameter anchors with 4-inch nominal embedment, 4-inch long anchors.

For 3/4-inch-diameter anchors with 5-inch nominal embedment, 5-inch long anchors.

<sup>10</sup>Mean values shown, actual stiffness varies considerably depending on concrete strength, loading and geometry of application.

TABLE 1B—HANGER MATE+ ANCHOR INSTALLATION AND SUPPLEMENTAL INFORMATION<sup>1,2</sup>

Anchor Property / Setting Information	Notation	Units	Nominal Anchor Size (inch)								
			1/4	3/8				1/2			
Coupler thread size (UNC)	-	in.	1/4-20	3/8-16						1/2-13	
Coupler head style	-	-	Internally Threaded	Internally Threaded	External Thread	Internally Threaded	Internally Threaded				
Nominal anchor diameter (screw anchor body)	$d_a$	in. (mm)	0.250 (6.4)				0.375 (9.5)				
Nominal drill bit diameter (ANSI)	$d_{bit}$	in.	1/4				3/8				
Minimum nominal embedment depth <sup>4</sup>	$h_{nom}$	in. (mm)	1 5/8 (41)	1 5/8 (41)	2 1/2 (64)	1 5/8 (41)	2 1/2 (64)	2 (51)	2 1/2 (64)	2 (51)	2 1/2 (64)
Effective embedment	$h_{ef}$	in. (mm)	1.20 (30)	1.20 (30)	1.94 (49)	1.20 (30)	1.94 (49)	1.33 (33)	1.75 (44)	1.33 (33)	1.75 (44)
Minimum hole depth	$h_o$	in. (mm)	2 (51)	2 (51)	2 7/8 (73)	2 (51)	2 7/8 (73)	2 3/8 (60)	2 7/8 (73)	2 3/8 (60)	2 7/8 (73)
Minimum concrete member thickness	$h_{min}$	in. (mm)	3 1/4 (83)	3 1/4 (83)	4 (102)	3 1/4 (83)	4 (102)	3 1/2 (89)	4 (102)	3 1/2 (89)	4 (102)
Minimum edge distance <sup>5</sup>	$c_{min}$	in. (mm)	1 1/2 (38)	1 1/2 (38)	1 1/2 (38)	1 1/2 (38)	1 1/2 (38)	$c_{min} = 1 1/2 (38)$ for $s_{min} \geq 3 (76)$ ;		$c_{min} = 1 1/2 (38)$ for $s_{min} \geq 3 (76)$ ;	
Minimum spacing distance <sup>5</sup>	$s_{min}$	in. (mm)	1 1/2 (38)	1 1/2 (38)	1 1/2 (38)	1 1/2 (38)	1 1/2 (38)	$s_{min} = 2 (51)$ for $c_{min} \geq 2 (51)$		$s_{min} = 2 (51)$ for $c_{min} \geq 2 (51)$	
Nominal anchor length <sup>6</sup>	$l_{anch}$	in.	1 5/8	1 5/8	2 1/2	1 5/8	2 1/2	2	2 1/2	2	2 1/2
Maximum impact wrench power (torque)	$T_{impact,max}$	ft.-lb. (N-m)	150 (203)	150 (203)	150 (203)	150 (203)	150 (203)	300 (407)	300 (407)	300 (407)	300 (407)
Maximum manual installation torque	$T_{inst,max}$	ft.-lb. (N-m)	19 <sup>[3]</sup> (26)	19 <sup>[3]</sup> (26)	25 (34)	19 <sup>[3]</sup> (26)	25 (34)	25 (34)	25 (34)	25 (34)	25 (34)
Coupler Head	Wrench socket size	-	in.	3/8	1/2	1/2	1/2	1/2	1 1/16		
	Max. head height	-	in.	33/64	43/64	1 3/16	43/64	53/64			
	Max. washer diameter	-	in.	1/2	21/32	21/32	21/32	31/32			
Effective tensile stress area (screw anchor body)	$A_{se}$	in. <sup>2</sup> (mm <sup>2</sup> )	0.045 (28.8)				0.094 (60.7)				
Minimum specified ultimate strength	$f_{uta}$	psi (N/mm <sup>2</sup> )	115,000 (793)				100,000 (690)				
Minimum specified yield strength	$f_{ya}$	psi (N/mm <sup>2</sup> )	92,000 (634)				80,000 (552)				
Mean axial stiffness <sup>7</sup>	Uncracked concrete	$\beta_{uncr}$	lbf/in.	1,381,000				1,157,000			
	Cracked concrete	$\beta_{cr}$	lbf/in.	318,000				330,000			

For SI: 1 inch = 25.4 mm, 1 ft-lb = 1.356 N-m, 1 psi = 0.0069 N/mm<sup>2</sup> (MPa).

<sup>1</sup>The information presented in this table is used in conjunction with the design criteria of ACI 318-19 Chapter 17.

<sup>2</sup>For installations through the soffit of steel deck assemblies into concrete, see Table 6 and the installation detail in Figures 6A and 6B of this report.

<sup>3</sup>For installations into lightweight concrete, the maximum manual installation torque,  $T_{inst,max}$ , is 18 ft.-lb.

<sup>4</sup>The embedment depth,  $h_{nom}$ , is measured from the outside surface of the concrete member to the embedded end of the anchor.

<sup>5</sup>Additional combinations for minimum edge distance,  $c_{min}$ , and minimum spacing distance,  $s_{min}$ , may be derived by linear interpolation between the given boundary values for the nominal 3/8-inch-diameter anchors (screw anchor body diameter).

<sup>6</sup>The listed anchor length is based on coupler head anchor sizes commercially available at the time of publication compared with the requirements to achieve the minimum nominal embedment depth. The nominal anchor length is measured from under the coupler head to the tip of the anchor.

<sup>7</sup>Mean values shown, actual stiffness varies considerably depending on concrete strength, loading and geometry of application.

**TABLE 2—ANCHOR SETTING INFORMATION FOR INSTALLATION ON THE TOP OF CONCRETE-FILLED STEEL DECK ASSEMBLIES WITH MINIMUM TOPPING THICKNESS<sup>1,2,3,4,10</sup>**

Anchor Property / Setting Information	Notation	Units	Nominal Anchor Size (inch)					
			<sup>1</sup> / <sub>4</sub> Screw-Bolt+			<sup>3</sup> / <sub>8</sub> Screw-Bolt+		<sup>1</sup> / <sub>2</sub> Screw-Bolt+
Head style	-	-	Hex or Flat Head			Hex or Flat Head		Hex or Flat Head
Nominal anchor diameter (screw anchor body)	$d_a$	in. (mm)	0.250 (6.4)			0.375 (9.5)		0.500 (12.7)
Minimum diameter of hole clearance in fixture <sup>5</sup>	$d_h$	in. (mm)	<sup>11</sup> / <sub>32</sub> (8.7)			<sup>1</sup> / <sub>2</sub> (12.7)		<sup>5</sup> / <sub>8</sub> (15.9)
Nominal drill bit diameter (ANSI)	$d_{bit}$	in.	<sup>1</sup> / <sub>4</sub>			<sup>3</sup> / <sub>8</sub>		<sup>1</sup> / <sub>2</sub>
Minimum nominal embedment depth <sup>6</sup>	$h_{nom}$	in. (mm)	<sup>1</sup> / <sub>8</sub> (41)	2 (51)	<sup>2</sup> / <sub>12</sub> (64)	2 (51)	<sup>2</sup> / <sub>12</sub> (64)	<sup>2</sup> / <sub>12</sub> (64)
Effective embedment	$h_{ef}$	in. (mm)	1.20 (30)	1.52 (39)	1.94 (49)	1.33 (33)	1.75 (44)	1.75 (44)
Minimum hole depth	$h_o$	in. (mm)	2 (51)	<sup>2</sup> / <sub>8</sub> (60)	<sup>2</sup> / <sub>12</sub> (64)	<sup>2</sup> / <sub>8</sub> (60)	<sup>2</sup> / <sub>12</sub> (64)	<sup>2</sup> / <sub>12</sub> (64)
Minimum concrete member thickness (topping thickness)	$h_{min,deck}$	in. (mm)	<sup>2</sup> / <sub>12</sub> (64)			<sup>2</sup> / <sub>12</sub> (64)		<sup>2</sup> / <sub>12</sub> (64)
Minimum edge distance	$C_{min,deck,top}$	in. (mm)	<sup>1</sup> / <sub>2</sub> (38)			2 (51)	<sup>2</sup> / <sub>12</sub> (64)	<sup>2</sup> / <sub>12</sub> (64)
Minimum spacing distance	$S_{min,deck,top}$	in. (mm)	<sup>1</sup> / <sub>2</sub> (38)			2 (51)	<sup>2</sup> / <sub>12</sub> (64)	<sup>2</sup> / <sub>12</sub> (64)
Minimum nominal anchor length <sup>7,8</sup>	$l_{anch}$	in.	<sup>1</sup> / <sub>4</sub>	<sup>2</sup> / <sub>14</sub>	<sup>2</sup> / <sub>8</sub>	<sup>2</sup> / <sub>12</sub>	3	3
Maximum impact wrench power (torque)	$T_{impact,max}$	ft.-lb. (N-m)	150 (203)			300 (407)		300 (407)
Maximum manual installation torque	$T_{inst,max}$	ft.-lb. (N-m)	18 <sup>(9)</sup> (26)	25 <sup>(9)</sup> (34)		25 (34)		45 (61)

For SI: 1 inch = 25.4 mm, 1 ft-lbf = 1.356 N-m.

<sup>1</sup>The anchors may be installed in the topside of concrete-filled steel deck floor and roof assemblies in accordance with Section 4.3 of this report provided the concrete thickness above the upper flute meets the minimum thicknesses specified in this table. Minimum concrete member thickness,  $h_{min,deck}$ , refers to the concrete thickness above the upper flute (topping thickness). See Figure 4 of this report.

<sup>2</sup>Applicable to the following conditions:

For <sup>1</sup>/<sub>4</sub>-inch-diameter anchors with <sup>1</sup>/<sub>8</sub>-inch nominal embedment,  $2\frac{1}{2}$ -inch  $\leq h_{min,deck} < 3\frac{1}{4}$ -inch.

For <sup>1</sup>/<sub>4</sub>-inch-diameter anchors with 2-inch nominal embedment,  $2\frac{1}{2}$ -inch  $\leq h_{min,deck} < 3\frac{3}{4}$ -inch.

For <sup>1</sup>/<sub>4</sub>-inch-diameter anchors with <sup>2</sup>/<sub>12</sub>-inch nominal embedment,  $2\frac{1}{2}$ -inch  $\leq h_{min,deck} < 4$ -inch.

For <sup>3</sup>/<sub>8</sub>-inch-diameter anchors with 2-inch nominal embedment,  $2\frac{1}{2}$ -inch  $\leq h_{min,deck} < 3\frac{1}{2}$ -inch.

For <sup>3</sup>/<sub>8</sub>-inch-diameter anchors with <sup>2</sup>/<sub>12</sub>-inch nominal embedment,  $2\frac{1}{2}$ -inch  $\leq h_{min,deck} < 4$ -inch.

For <sup>1</sup>/<sub>2</sub>-inch-diameter anchors with <sup>2</sup>/<sub>12</sub>-inch nominal embedment,  $2\frac{1}{2}$ -inch  $\leq h_{min,deck} < 4\frac{1}{2}$ -inch.

<sup>3</sup>For all other anchor diameters and embedment depths, refer to Table 1 for applicable values of  $h_{min}$ ,  $C_{min}$  and  $S_{min}$ , which can be substituted for  $h_{min,deck}$ ,  $C_{min,deck,top}$  and  $S_{min,deck,top}$ , respectively.

<sup>4</sup>Design capacities must be based on calculations according to values in Tables 3A and 3B of this report.

<sup>5</sup>The minimum diameter of fixture hole clearance is for the body of the anchor to pass through structural steel members; clearance holes, may be <sup>1</sup>/<sub>8</sub>-inch less than tabulated values (same as nominal drill bit diameter) provided the screw anchors are installed through light gauge cold-formed steel members or wood members.

<sup>6</sup>The embedment depth,  $h_{nom}$ , is measured from the outside surface of the concrete member to the embedded end of the anchor.

<sup>7</sup>The listed minimum overall anchor length is based on the anchor sizes commercially available at the time of publication compared with the requirements to achieve the minimum nominal embedment depth, including consideration of a fixture attachment. Longer length anchors may be selected for larger fixture thickness requirements, see Figure 1A. The minimum nominal length of hex head anchors is measured from under the head to the tip of the anchor, the minimum nominal length for flat head anchors is measured from the top of the head to the tip of the anchor.

<sup>8</sup>Hex head anchors with the following minimum lengths are also suitable for use with cold-formed steel members provided the nominal thickness of the fixture attachment does not exceed 20 gauge (0.036-inch base metal thickness):

For <sup>3</sup>/<sub>8</sub>-inch or <sup>1</sup>/<sub>2</sub>-inch-diameter anchors with <sup>2</sup>/<sub>12</sub>-inch nominal embedment, <sup>2</sup>/<sub>12</sub>-inch long anchors.

<sup>9</sup>Installation with <sup>1</sup>/<sub>4</sub>-inch-diameter anchors using a manual torque wrench is limited to a maximum concrete compressive strength of 4,000 psi (27.6 MPa).

<sup>10</sup>For socket and driver sizes, head and washer diameter, head height and supplemental information see Table 1A.

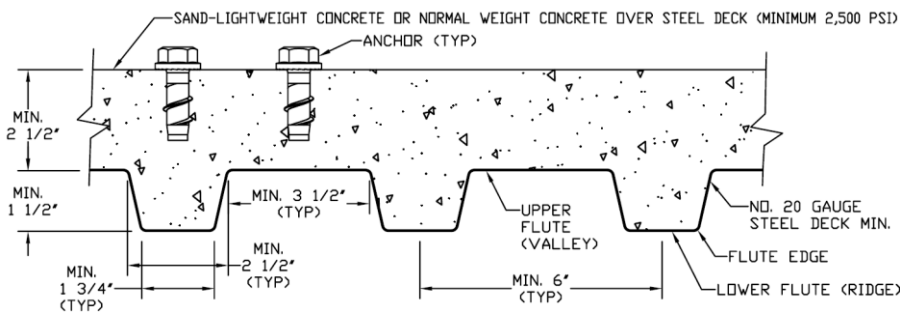

<sup>1</sup>Anchors may be placed in the top side of concrete over steel deck profiles in accordance with Figure 4 provided the minimum concrete thickness above the upper flute (topping thickness) is satisfied. See installation information given in Table 2 of this report.

<sup>2</sup>For all other anchor diameters and embedment depths installed in the top of concrete over steel deck profiles with topping thickness greater than or equal to the minimum concrete member thicknesses given in Table 1A, the minimum spacing distances and minimum edge distances must be used from Table 1A, as applicable.

<sup>3</sup>See Tables 3A and 3B of this report for design data.

**FIGURE 4—INSTALLATION DETAIL FOR ANCHORS IN THE TOP OF CONCRETE OVER STEEL DECK FLOOR AND ROOF ASSEMBLIES WITH MINIMUM TOPPING THICKNESS (SEE DIMENSIONAL PROFILE REQUIREMENTS)<sup>1,2,3</sup>**

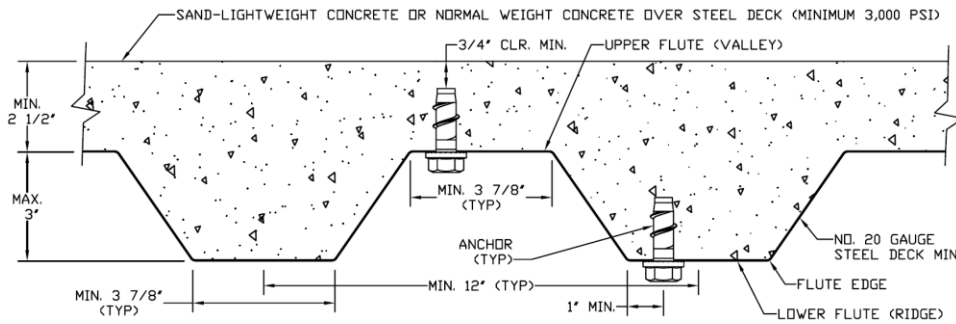

- <sup>1</sup> Anchors may be placed in the upper flute or lower flute of concrete-filled steel deck profiles in accordance with [Figure 5A](#) provided the minimum hole clearance of  $\frac{3}{4}$ -inch is satisfied for the selected anchor.
- <sup>2</sup> Anchors in the lower flute of [Figure 5A](#) profiles may be installed with a maximum  $\frac{15}{16}$ -inch offset in either direction from the center of the flute. The offset distance may be increased proportionally for profiles with lower flute widths greater than those shown provided the minimum lower flute edge distance is also satisfied (e.g.  $\frac{1}{4}$ -inch offset for  $4\frac{1}{2}$ -inch wide flute).
- <sup>3</sup> Minimum spacing for anchors installed in the lower flute must be equal to the greater of  $3h_{ef}$  or 1.5 times flute width.
- <sup>4</sup> See [Table 5](#) of this report for design data.

**FIGURE 5A—SCREW-BOLT+ INSTALLATION DETAIL FOR ANCHORS IN THE SOFFIT OF CONCRETE OVER STEEL DECK FLOOR AND ROOF ASSEMBLIES (SEE DIMENSIONAL PROFILE REQUIREMENTS)<sup>1,2,3,4</sup>**

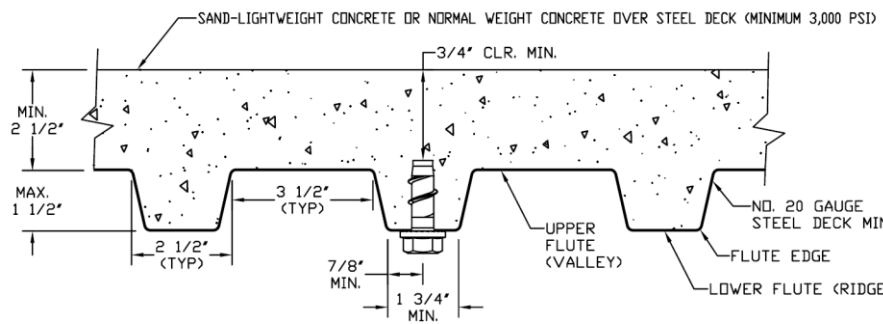

- <sup>1</sup> Anchors may be placed in the upper flute or lower flute of the concrete-filled steel deck profiles in accordance with [Figure 5B](#) provided the minimum hole clearance of  $\frac{3}{4}$ -inch is satisfied for the selected anchor.
- <sup>2</sup> Anchors in the lower flute of [Figure 5B](#) profiles may be installed in the center of the flute. An offset distance may be given proportionally for profiles with flute widths greater than those shown provided the minimum lower flute edge distance is also satisfied.
- <sup>3</sup> Minimum spacing for anchors installed in the lower flute must be equal to the greater of  $3h_{ef}$  or 1.5 times flute width.
- <sup>4</sup> See [Table 5](#) of this report for design data.

**FIGURE 5B— SCREW-BOLT+ INSTALLATION DETAIL FOR ANCHORS IN THE SOFFIT OF CONCRETE OVER STEEL DECK FLOOR AND ROOF ASSEMBLIES (SEE DIMENSIONAL PROFILE REQUIREMENTS)<sup>1,2,3</sup>**

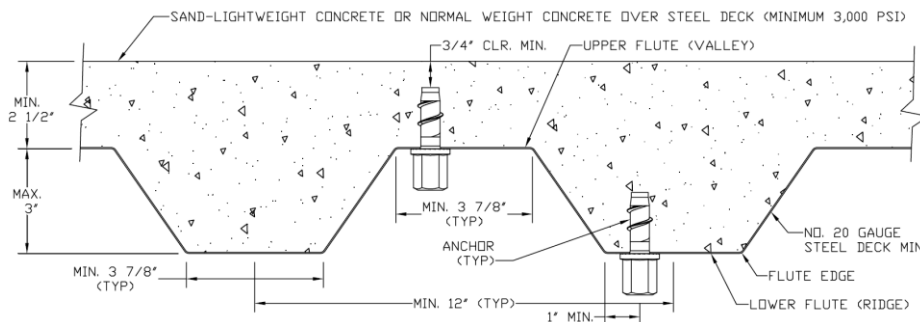

- <sup>1</sup> Anchors may be placed in the upper flute or lower flute of the concrete-filled steel deck profiles in accordance with [Figure 6A](#) provided the minimum hole clearance of  $\frac{3}{4}$ -inch is satisfied for the selected anchor.
- <sup>2</sup> Anchors in the lower flute of [Figure 6A](#) profiles may be installed with a maximum  $\frac{15}{16}$ -inch offset in either direction from the center of the flute. The offset distance may be increased proportionally for profiles with lower flute widths greater than those shown provided the minimum lower flute edge distance is also satisfied (e.g.  $\frac{1}{4}$ -inch offset for  $4\frac{1}{2}$ -inch wide flute).
- <sup>3</sup> Minimum spacing for anchors installed in the lower flute must be equal to the greater of  $3h_{ef}$  or 1.5 times flute width
- <sup>4</sup> See [Table 6](#) of this report for design data.

**FIGURE 6A—HANGERMATE+ INSTALLATION DETAIL FOR SCREW ANCHORS IN THE SOFFIT OF CONCRETE OVER STEEL DECK FLOOR AND ROOF ASSEMBLIES (SEE DIMENSIONAL PROFILE REQUIREMENTS)<sup>1,2,3</sup>**

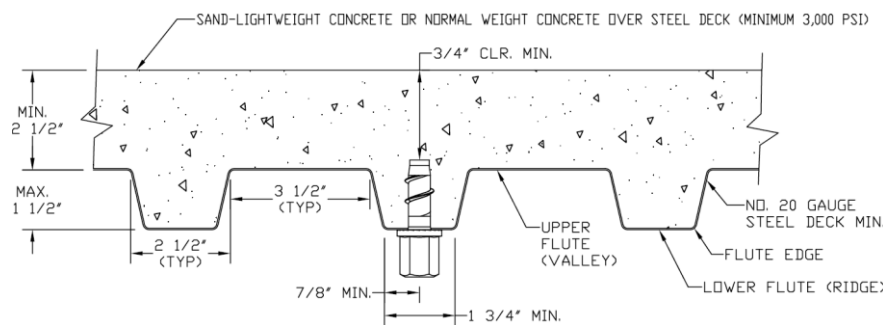

- <sup>1</sup> Anchors may be placed in the upper flute or lower flute of the concrete-filled steel deck profiles in accordance with [Figure 6B](#) provided the minimum hole clearance of  $\frac{3}{4}$ -inch is satisfied for the selected anchor.
- <sup>2</sup> Anchors in the lower flute of [Figure 6B](#) profiles may be installed in the center of the flute. An offset distance may be given proportionally for profiles with flute widths greater than those shown provided the minimum lower flute edge distance is also satisfied.
- <sup>3</sup> Minimum spacing for anchors installed in the lower flute must be equal to the greater of  $3h_{ef}$  or 1.5 times flute width.
- <sup>4</sup> See [Table 6](#) of this report for design data.

**FIGURE 6B—HANGERMATE+ INSTALLATION DETAIL FOR SCREW ANCHORS IN THE SOFFIT OF CONCRETE OVER STEEL DECK FLOOR AND ROOF ASSEMBLIES (SEE DIMENSIONAL PROFILE REQUIREMENTS)<sup>1,2,3</sup>**

TABLE 3A—TENSION DESIGN INFORMATION FOR SCREW-BOLT+ ANCHORS IN CONCRETE<sup>1,2,3889</sup>

9

Anchor Property / Setting Information	Notation	Units	Nominal Anchor Size (inch)																			
			1/4		3/8		1/2		5/8				3/4									
Anchor category	1, 2 or 3	-	1		1		1		1				1									
Head style	-	-	Hex or Flat Head				Hex or Flat Head		Hex or Flat Head		Hex Head				Hex Head							
Nominal anchor diameter (screw anchor body)	$d_a$	in. (mm)	0.250 (6.4)		0.375 (9.5)		0.500 (12.7)		0.625 (15.9)				0.750 (19.1)									
Minimum nominal embedment depth	$h_{nom}$	in. (mm)	1 <sup>5/8</sup> (41)	2 (51)	2 <sup>1/2</sup> (64)	2 (51)	2 <sup>1/2</sup> (64)	3 <sup>1/4</sup> (83)	2 <sup>1/2</sup> (64)	3 (76)	3 <sup>1/2</sup> (89)	4 <sup>1/4</sup> (108)	3 <sup>1/4</sup> (83)	3 <sup>5/8</sup> (92)	4 (102)	4 <sup>1/2</sup> (114)	5 (127)	4 <sup>1/4</sup> (108)	5 <sup>1/4</sup> (133)	6 <sup>1/4</sup> (159)	7 <sup>1/4</sup> (184)	
Effective embedment	$h_{ef}$	in. (mm)	1.20 (30)	1.52 (39)	1.94 (49)	1.33 (33)	1.75 (44)	2.39 (60)	1.75 (44)	2.17 (55)	2.60 (66)	3.23 (82)	2.24 (56)	2.56 (65)	2.88 (73)	3.30 (84)	3.73 (94)	3.08 (78)	3.93 (100)	4.78 (122)	5.63 (143)	
<b>STEEL STRENGTH IN TENSION (ACI 318-19 Section 17.6.1)</b>																						
Steel strength in tension	$N_{sa}$	lb (kN)	4,535 (20.2)		8,730 (38.8)		20,475 (91.1)		26,260 (116.8)				38,165 (169.8)									
Reduction factor, steel strength <sup>3,4</sup>	$\phi$	-	0.65																			
<b>CONCRETE BREAKOUT STRENGTH IN TENSION (ACI 318-19 Section 17.6.2)</b>																						
Critical edge distance (uncracked concrete)	$c_{ac}$	in. (mm)	4.3 (110)	5.1 (130)	6.1 (156)	5.0 (127)	6.3 (160)	7.8 (298)	4.9 (125)	5.9 (150)	6.8 (173)	8.1 (205)	6.3 (159)	7.1 (180)	7.9 (201)	9.0 (229)	10.1 (255)	7.0 (178)	8.3 (211)	9.4 (239)	12.4 (315)	
Critical edge distance for topside of concrete-filled steel decks with minimum topping thickness (uncracked concrete) <sup>11</sup>	$c_{ac,deck,top}$	in. (mm)	3.0 (76)	3.5 (89)	4.0 (102)	3.5 (89)	6.0 (152)	See note 11	6.0 (152)	See note 11			See note 11				See note 11					
Effectiveness factor for uncracked concrete	$k_{uncr}$	-	27	24		30	24		30	24			30	24			27	24				
Effectiveness factor for cracked concrete	$k_{cr}$	-	17			17			17			21			17			21				
Modification factor, cracked and uncracked concrete <sup>5</sup>	$\psi_{c,N}$	-	1.0			1.0			1.0			1.0			1.0							
Reduction factor, concrete breakout strength <sup>3</sup>	$\phi$	-	0.65																			
<b>PULLOUT STRENGTH IN TENSION (ACI 318-19 Section 17.6.3)</b>																						
Pullout strength, uncracked concrete (2,500 psi) <sup>6,10</sup>	$N_{p,uncr}$	lb (kN)	See note 7		See note 7		See note 7				See note 7				See note 7				17,675 (78.6)			
Pullout strength, cracked concrete (2,500 psi) <sup>6,10</sup>	$N_{p,cr}$	lb (kN)	765 (3.4)	1,025 (4.6)	1,415 (6.3)	See note 7			1,645 (7.3)	2,515 (11.2)	3,390 (15.1)	4,700 (20.9)	3,080 (13.7)	3,900 (17.3)	4,720 (21.0)	5,810 (25.9)	6,900 (30.7)	See note 7				
Reduction factor, pullout strength <sup>3</sup>	$\phi$	-	0.65																			
<b>PULLOUT STRENGTH IN TENSION FOR SEISMIC APPLICATIONS (ACI 318-19 Section 17.10.3)</b>																						
Pullout strength, seismic (2,500 psi) <sup>6,8,10</sup>	$N_{p,eq}$	lb (kN)	360 (1.6)	640 (2.9)	1,170 (5.2)	900 (4.0)	1,645 (7.3)	2,765 (12.3)	1,645 (7.3)	2,515 (11.2)	3,390 (15.1)	4,700 (20.9)	1,910 (8.5)	2,310 (10.3)	2,660 (11.8)	3,060 (13.6)	3,370 (15.0)	4,085 (18.2)	5,885 (26.2)	See note 7		
Reduction factor, pullout strength, seismic <sup>3</sup>	$\phi$	-	0.65																			

For **S**: 1 inch = 25.4 mm, 1 ft-lb = 1.356 N-m, 1 psi = 0.0069 N/mm<sup>2</sup> (MPa).

<sup>1</sup>The data in this table is intended to be used with the design provisions of ACI 318-19 Chapter 17; for anchors resisting seismic load combinations the additional requirements of ACI 318-19 Section 17.10 must apply.

<sup>2</sup>Installation must comply with manufacturer's published installation instructions and details.

<sup>3</sup> The strength reduction factor applies when the load combinations from the 2024 IBC or ACI 318-19 are used and the requirements of ACI 318-19 Section 17.5.3 are met.

<sup>4</sup>The anchors are considered brittle steel elements as defined by ACI 318-19 Section 2.3.

<sup>5</sup>Select the appropriate effectiveness factor for cracked concrete ( $k_{cr}$ ) or uncracked concrete ( $k_{uncr}$ ) and use  $\psi_{c,N} = 1.0$ .

<sup>6</sup>For calculation of  $N_{p,cr}$  see Section 4.1.4 of this report. The characteristic pullout strength for concrete compressive strengths greater than 2,500 psi for 1/4-inch-diameter anchors may be increased by multiplying the value in the table by  $(f_c / 2,500)^{0.3}$  for psi or  $(f_c / 17.2)^{0.3}$  for MPa. The characteristic pullout strength for concrete compressive strengths greater than 2,500 psi for 3/8-inch- to 3/4-inch-diameter anchors may be increased by multiplying the value in the table by  $(f_c / 2,500)^{0.5}$  for psi or  $(f_c / 17.2)^{0.5}$  for MPa, with the exception of the 3/4-inch-diameter anchors with 7 1/4-inch embedment which may be increased by multiplying the value in the table by  $(f_c / 2,500)^{0.35}$  for psi or  $(f_c / 17.2)^{0.35}$ .

<sup>7</sup>Pullout strength does not control design of indicated anchors and does not need to be calculated for indicated anchor size and embedment.

<sup>8</sup>Reported values for characteristic pullout strength in tension for seismic applications are based on test results per ACI 355.2, Section 9.5.

<sup>9</sup>Anchors are permitted in the topside of concrete-filled steel deck assemblies in accordance with Figure 4 of this report.

<sup>10</sup>Anchors are permitted to be used in lightweight concrete in accordance with Section 4.1.12 of this report.

<sup>11</sup>Tabulated critical edge distance values,  $c_{ac,deck,top}$ , are for anchors installed in the top of concrete over steel deck profiles with a minimum concrete thickness,  $h_{min,deck}$ , of 2.5 inches above the upper flute (topping thickness). For minimum topping thicknesses greater than or equal to the minimum concrete member thicknesses,  $h_{min}$ , given in Table 1A, the associated critical edge distance,  $c_{ac}$ , for indicated anchor diameters and embedment depths may be used in the calculation of  $\psi_{cp,N}$ , in accordance with Section 4.1.10 of this report, as applicable.

TABLE 3B—SHEAR DESIGN INFORMATION FOR SCREW-BOLT+ ANCHORS IN CONCRETE<sup>1,2,7,8</sup>

Anchor Property / Setting Information	Notation	Units	Nominal Anchor Size (inch)																			
			1/4		3/8		1/2		5/8				3/4									
Anchor category	1, 2 or 3	-	1		1		1		1				1									
Head style	-	-	Hex Head or Flat Head		Hex Head or Flat Head		Hex Head or Flat Head		Hex Head				Hex Head									
Nominal anchor diameter (screw anchor body)	$d_a$	in. (mm)	0.250 (6.4)		0.375 (9.5)		0.500 (12.7)		0.625 (15.9)				0.750 (19.1)									
Minimum nominal embedment depth	$h_{nom}$	in. (mm)	1 5/8 (41)	2 (51)	2 1/2 (64)	2 (51)	2 1/2 (64)	3 1/4 (83)	2 1/2 (64)	3 (76)	3 1/2 (89)	4 1/4 (108)	3 1/4 (83)	3 5/8 (92)	4 (102)	4 1/2 (114)	5 (127)	4 1/4 (108)	5 1/4 (133)	6 1/4 (159)	7 1/4 (184)	
Effective embedment depth	$h_{ef}$	in. (mm)	1.20 (30)	1.52 (39)	1.94 (49)	1.33 (33)	1.75 (44)	2.39 (60)	1.75 (44)	2.17 (55)	2.60 (66)	3.23 (82)	2.24 (56)	2.56 (65)	2.88 (73)	3.30 (84)	3.73 (94)	3.08 (78)	3.93 (100)	4.78 (122)	5.63 (143)	
<b>STEEL STRENGTH IN SHEAR (ACI 318-19 Section 17.7.1)</b>																						
Steel strength in shear <sup>5</sup>	$V_{sa}$	lb (kN)	1,635 (7.3)	2,040 (9.1)	3,465 (15.4)	4,345 (19.3)	8,860 (39.4)	11,175 (49.7)	12,310 (54.8)	15,585 (69.3)	19,260 (85.7)	22,900 (101.9)										
Reduction factor, steel strength <sup>3,4</sup>	$\phi$	-	0.60																			
<b>STEEL STRENGTH IN SHEAR FOR SEISMIC APPLICATIONS (ACI 318-19 Section 17.10.3)</b>																						
Steel strength in shear, seismic <sup>6</sup>	$V_{sa,eq}$	lb (kN)	1,360 (6.1)	1,700 (7.6)	2,415 (10.8)	3,030 (13.5)	7,090 (31.5)	8,940 (39.8)	9,845 (43.8)	12,465 (55.5)	15,405 (68.5)	18,685 (83.1)										
Reduction factor, steel strength, seismic <sup>3</sup>	$\phi$	-	0.60																			
<b>CONCRETE BREAKOUT STRENGTH IN SHEAR (ACI 318-19 Section 17.7.2)</b>																						
Load bearing length of anchor	$\ell_e$	in. (mm)	1.20 (30)	1.52 (39)	1.94 (49)	1.33 (33)	1.75 (44)	2.39 (60)	1.75 (44)	2.17 (55)	2.60 (66)	3.23 (82)	2.24 (56)	2.56 (65)	2.88 (73)	3.30 (84)	3.73 (94)	3.08 (78)	3.93 (100)	4.78 (122)	5.63 (143)	
Reduction factor, concrete breakout strength <sup>3</sup>	$\phi$	-	0.70																			
<b>PRYOUT STRENGTH IN SHEAR (ACI 318-19 Section 17.7.3)</b>																						
Coefficient for prout strength	$k_{cp}$	-	1		1		1		2		1		2		2							
Reduction factor, prout strength <sup>3</sup>	$\phi$	-	0.70																			

For SI: 1 inch = 25.4 mm, 1 ft-lb = 1.356 N-m, 1 psi = 0.0069 N/mm<sup>2</sup> (MPa).

<sup>1</sup>The data in this table is intended to be used with the design provisions of ACI 318-19 Chapter 17; for anchors resisting seismic load combinations the additional requirements of ACI 318-19 Section 17.10 must apply.

<sup>2</sup>Installation must comply with manufacturer's published installation instructions and details.

<sup>3</sup>The strength reduction factor applies when load combinations from the 2024 IBC or ACI 318-19 are used and requirements of ACI 318-19 Section 17.5.3 are met.

<sup>4</sup>The anchors are considered brittle steel elements as defined by ACI 318-19 Section 2.3.

<sup>5</sup>Reported values for steel strength in shear are based on tests per ACI 355.2, Section 9.4 and must be used for design in lieu of the calculated results using equation 17.7.1.2b in ACI 318-19.

<sup>6</sup>Reported values for steel strength in shear are for seismic applications and based on test results in accordance with ACI 355.2, Section 9.6.

<sup>7</sup>Anchors are permitted in the topside of concrete-filled steel deck assemblies in accordance with Figure 4 of this report.

<sup>8</sup>Anchors are permitted to be used in lightweight concrete in accordance with Section 4.1.12 of this report.

TABLE 4—TENSION AND SHEAR DESIGN INFORMATION FOR HANGERMATE+ ANCHORS IN CONCRETE<sup>1,2,9,13</sup>

Anchor Property / Setting Information	Notation	Units	Nominal Anchor Size (inch)								
			1/4	3/8				1/2			
Anchor category	1, 2 or 3	-	1	1				1			
Coupler thread size (UNC)	-	in.	1/4 -20	3/8 -16				1/2 -13			
Coupler head style	-	-	Int. Threaded	Int. Threaded	Ext. Thread	Int. Threaded	Int. Threaded				
Nominal anchor diameter (screw anchor body)	$d_a$	in. (mm)	0.250 (6.4)				0.375 (9.5)				
Minimum nominal embedment depth	$h_{nom}$	in. (mm)	1 <sup>5</sup> / <sub>8</sub> (41)	1 <sup>5</sup> / <sub>8</sub> (41)	2 <sup>1</sup> / <sub>2</sub> (64)	1 <sup>5</sup> / <sub>8</sub> (41)	2 <sup>1</sup> / <sub>2</sub> (64)	2 (51)	2 <sup>1</sup> / <sub>2</sub> (64)	2 (51)	2 <sup>1</sup> / <sub>2</sub> (64)
Effective embedment	$h_{ef}$	in. (mm)	1.20 (30)	1.20 (30)	1.94 (49)	1.20 (30)	1.94 (49)	1.33 (33)	1.75 (44)	1.33 (33)	1.75 (44)
<b>STEEL STRENGTH IN TENSION (ACI 318-19 Section 17.6.1)</b>											
Steel strength in tension	$N_{sa}$	lb (kN)	4,535 (20.2)				8,730 (38.8)				
Reduction factor, steel strength <sup>3,4</sup>	$\phi$	-	0.65								
<b>CONCRETE BREAKOUT STRENGTH IN TENSION (ACI 318-19 Section 17.6.2)</b>											
Critical edge distance (uncracked concrete)	$C_{ac}$	in. (mm)	4.3 (110)	4.3 (110)	6.1 (156)	4.3 (110)	6.1 (156)	5.0 (127)	6.3 (160)	5.0 (127)	6.3 (160)
Effectiveness factor for uncracked concrete	$k_{unscr}$	-	27	27	24	27	24	30	24	30	24
Effectiveness factor for cracked concrete	$k_{cr}$	-	17	17	17	17	17	17	17	17	17
Modification factor, cracked and uncracked concrete <sup>5</sup>	$\psi_{c,N}$	-	1.0	1.0	1.0	1.0	1.0	1.0	1.0	1.0	1.0
Reduction factor, concrete breakout strength <sup>3</sup>	$\phi$	-	0.65								
<b>PULLOUT STRENGTH IN TENSION (ACI 318-19 Section 17.6.3)</b>											
Pullout strength, uncracked concrete (2,500 psi) <sup>6,10</sup>	$N_{p,unscr}$	lb (kN)	See note 7	See note 7	See note 7	See note 7	See note 7	See note 7	See note 7	See note 7	See note 7
Pullout strength, cracked concrete (2,500 psi) <sup>6,10</sup>	$N_{p,cr}$	lb (kN)	765 (3.4)	765 (3.4)	1,415 (6.3)	765 (3.4)	1,415 (6.3)	See note 7	See note 7	See note 7	See note 7
Reduction factor, pullout strength <sup>3</sup>	$\phi$	-	0.65								
<b>PULLOUT STRENGTH IN TENSION FOR SEISMIC APPLICATIONS (ACI 318-19 Section 17.10.3)</b>											
Pullout strength, seismic (2,500 psi) <sup>6,8,10</sup>	$N_{p,eq}$	lb (kN)	360 (1.6)	360 (1.6)	1,170 (5.2)	360 (1.6)	1,170 (5.2)	900 (4.0)	1,645 (7.3)	900 (4.0)	1,645 (7.3)
Reduction factor, pullout strength, seismic <sup>3</sup>	$\phi$	-	0.65								
<b>STEEL STRENGTH IN SHEAR (ACI 318-19 Section 17.7.1)</b>											
Steel strength in shear <sup>11</sup>	$V_{sa}$	lb (kN)	860 (3.8)	1,360 (6.1)	1,360 (6.1)	1,360 (6.1)	1,295 (5.8)	1,900 (8.5)			
Reduction factor, steel strength <sup>3,4</sup>	$\phi$	-	0.60								
<b>STEEL STRENGTH IN SHEAR FOR SEISMIC APPLICATIONS (ACI 318-19 Section 17.10.3)</b>											
Steel strength in shear, seismic <sup>12</sup>	$V_{sa,eq}$	lb (kN)	600 (2.7)	695 (3.1)	695 (3.1)	695 (3.1)	800 (3.6)	800 (3.6)			
Reduction factor, steel strength, seismic <sup>3,4</sup>	$\phi$	-	0.60								
<b>CONCRETE BREAKOUT STRENGTH IN SHEAR (ACI 318-19 Section 17.7.2)</b>											
Load bearing length of anchor	$\ell_e$	in. (mm)	1.20 (30)	1.20 (30)	1.94 (49)	1.20 (30)	1.94 (49)	1.33 (33)	1.75 (44)	1.33 (33)	1.75 (44)
Reduction factor, concrete breakout strength <sup>3</sup>	$\phi$	-	0.70								
<b>PRYOUT STRENGTH IN SHEAR (ACI 318-19 Section 17.7.3)</b>											
Coefficient for prying strength	$k_{cp}$	-	1	1	1	1	1	1	1	1	1
Reduction factor, prying strength <sup>3</sup>	$\phi$	-	0.70								

For **SI**: 1 inch = 25.4 mm, 1 ft-lb = 1.356 N-m, 1 psi = 0.0069 N/mm<sup>2</sup> (MPa).

<sup>1</sup>The data in this table is intended to be used with the design provisions of ACI 318-19 Chapter 17; for anchors resisting seismic load combinations the additional requirements of ACI 318-19 Section 17.10 must apply.

<sup>2</sup>Installation must comply with manufacturer's published installation instructions and details.

<sup>3</sup> The strength reduction factor applies when the load combinations from the 2024 IBC or ACI 318-19 are used and the requirements of ACI 318-19 Section 17.5.3 are met.

<sup>4</sup>The anchors are considered a brittle steel elements as defined by ACI 318-19 Section 2.3.

<sup>5</sup>Select the appropriate effectiveness factor for cracked concrete ( $k_{cr}$ ) or uncracked concrete ( $k_{unscr}$ ) and use  $\psi_{c,N} = 1.0$ .

<sup>6</sup>For calculation of  $N_{pn}$  see Section 4.1.4 of this report. The characteristic pullout strength for concrete compressive strengths greater than 2,500 psi for 1/4-inch-diameter anchors (screw anchor body diameter) may be increased by multiplying the value in the table by  $(F_c / 2,500)^{0.3}$  for psi or  $(F_c / 17.2)^{0.3}$  for MPa. The characteristic pullout strength for concrete compressive strengths greater than 2,500 psi for 3/8-inch-diameter anchors (screw anchor body diameter) may be increased by multiplying the value in the table by  $(F_c / 2,500)^{0.5}$  for psi or  $(F_c / 17.2)^{0.5}$  for MPa.

<sup>7</sup>Pullout strength does not control design of indicated anchors and does not need to be calculated for indicated anchor size and embedment.

<sup>8</sup>Reported values for characteristic pullout strength in tension for seismic applications are based on test results per ACI 355.2, Section 9.5.

<sup>9</sup>Anchors are permitted in the top side of concrete-filled steel deck assemblies in accordance with Figure 4 of this report.

<sup>10</sup>Anchors are permitted to be used in lightweight concrete in accordance with Section 4.1.12 of this report.

<sup>11</sup>Reported values for steel strength in shear are based on test results per ACI 355.2, Section 9.4 and must be used for design in lieu of the calculated results using equation 17.7.1.2b in ACI 318-19.

<sup>12</sup>Reported values for steel strength in shear are for seismic applications and based on tests in accordance with ACI 355.2, Section 9.6.

<sup>13</sup>HangerMate+ shear values are for threaded rod or steel inserts with ultimate strength,  $F_u \geq 125$  ksi; threaded rod or steel inserts with an  $F_u$  less than 125 ksi are allowed provided the steel strength shear values are multiplied by the ratio of  $F_u$  (ksi) of the steel insert and 125 ksi.

**TABLE 5—TENSION AND SHEAR DESIGN INFORMATION FOR SCREW-BOLT+ ANCHORS IN THE SOFFIT (THROUGH THE UNDERSIDE) OF CONCRETE-FILLED STEEL DECK ASSEMBLIES<sup>1,2,3,4,5,6,7</sup>**

Anchor Property / Setting Information	Notation	Units	Nominal Anchor Size (inch)																		
			1/4			3/8			1/2			5/8			3/4						
Anchor category	1, 2 or 3	-	1			1			1			1			1						
Head style	-	-	Hex or Flat Head			Hex or Flat Head			Hex or Flat Head			Hex Head			Hex Head						
Nominal anchor diameter (screw anchor body)	$d_a$	in. (mm)	0.250 (6.4)			0.375 (9.5)			0.500 (12.7)			0.625 (15.9)			0.750 (19.1)						
Minimum nominal embedment depth	$h_{nom}$	in. (mm)	1 <sup>5/8</sup> (41)	2 (51)	2 <sup>1/2</sup> (64)	2 (51)	2 <sup>1/2</sup> (64)	3 <sup>1/4</sup> (83)	2 <sup>1/2</sup> (64)	3 (76)	3 <sup>1/2</sup> (89)	4 <sup>1/4</sup> (108)	3 <sup>1/4</sup> (83)	3 <sup>5/8</sup> (92)	4 (102)	4 <sup>1/2</sup> (114)	5 (127)	4 <sup>1/4</sup> (108)			
Effective embedment	$h_{ef}$	in. (mm)	1.20 (30)	1.52 (39)	1.94 (49)	1.33 (33)	1.75 (44)	2.39 (60)	1.75 (44)	2.17 (55)	2.60 (66)	3.23 (82)	2.24 (56)	2.56 (65)	2.88 (73)	3.30 (84)	3.73 (94)	3.08 (78)			
<b>Screw-Bolt+ Anchors Installed into Minimum 3<sup>7/8</sup>-inch-wide Deck Flute (see Figure 5A)</b>																					
Minimum concrete member thickness <sup>7</sup>	$h_{min,deck,total}$	in. (mm)	5 <sup>1/2</sup> (140)			5 <sup>1/2</sup> (140)			5 <sup>1/2</sup> (140)			5 <sup>1/2</sup> (140)			6 <sup>1/4</sup> (159)		6 <sup>1/4</sup> (159)				
Pullout strength, uncracked concrete (3,000 psi)	$N_{p,deck,uncr}$	lb (kN)	1,430 (6.4)	1,915 (8.5)	2,555 (11.4)	2,275 (10.1)	2,655 (11.8)	3,235 (14.4)	2,600 (11.6)	3,555 (15.8)	4,540 (20.2)	5,975 (26.6)	2,610 (11.6)	3,380 (15.0)	4,150 (18.5)	5,160 (23.0)	6,195 (27.6)	6,085 (27.1)			
Pullout strength, cracked concrete (3,000 psi)	$N_{p,deck,cr}$	lb (kN)	560 (2.5)	800 (3.6)	1,020 (4.5)	1,290 (5.7)	1,880 (8.4)	2,290 (10.2)	1,125 (5.0)	2,130 (9.5)	2,795 (12.4)	3,680 (16.4)	1,460 (6.5)	2,450 (10.9)	3,050 (13.6)	3,805 (16.9)	4,515 (20.1)	3,835 (17.1)			
Pullout strength, seismic (3,000 psi)	$N_{p,deck,eq}$	lb (kN)	265 (1.2)	500 (2.2)	840 (3.7)	810 (3.6)	1,435 (6.4)	1,840 (8.2)	1,125 (5.0)	2,130 (9.5)	2,795 (12.4)	3,680 (16.4)	905 (4.0)	1,450 (6.5)	1,720 (7.7)	2,000 (8.9)	2,205 (9.8)	3,110 (13.8)			
Reduction factor, pullout strength <sup>8</sup>	$\phi$	-	0.65																		
Steel strength in shear	$V_{sa,deck}$	lb (kN)	1,155 (5.1)	1,155 (5.1)	2,595 (11.6)	2,540 (11.3)	2,540 (11.3)	3,225 (14.4)	2,435 (10.8)	2,435 (10.8)	2,435 (10.8)	5,845 (26.0)	2,650 (11.8)	2,650 (11.8)	2,650 (11.8)	2,650 (11.8)	6,325 (28.1)	5,175 (23.0)			
Steel strength in shear, seismic	$V_{sa,deck,eq}$	lb (kN)	960 (4.3)	960 (4.3)	2,165 (9.6)	1,775 (7.9)	1,775 (7.9)	2,250 (10.0)	1,950 (8.7)	1,950 (8.7)	1,950 (8.7)	4,675 (20.8)	2,120 (9.4)	2,120 (9.4)	2,120 (9.4)	2,120 (9.4)	5,060 (22.5)	4,140 (18.4)			
Reduction factor, steel strength in shear <sup>8</sup>	$\phi$	-	0.60																		
<b>Screw-Bolt+ Anchors Installed into Minimum 1<sup>3/4</sup>-inch-wide Deck Flute (see Figure 5B)</b>																					
Minimum concrete member thickness <sup>7</sup>	$h_{min,deck,total}$	in. (mm)	4 (102)			4 (102)			4 (102)			N/A			N/A			N/A			
Pullout strength, uncracked concrete (3,000 psi)	$N_{p,deck,uncr}$	lb (kN)	1,430 (6.4)	1,710 (7.6)	2,075 (9.2)	1,440 (6.4)	2,135 (9.5)	3,190 (14.2)	1,720 (7.6)	N/A									N/A		
Pullout strength, cracked concrete (3,000 psi)	$N_{p,deck,cr}$	lb (kN)	560 (2.5)	710 (3.2)	825 (3.7)	815 (3.6)	1,510 (6.7)	2,260 (10.0)	745 (3.3)	N/A									N/A		
Pullout strength, seismic (3,000 psi)	$N_{p,deck,eq}$	lb (kN)	265 (1.2)	445 (2.0)	685 (3.0)	515 (2.3)	1,155 (5.1)	1,815 (8.1)	745 (3.3)	N/A									N/A		
Reduction factor, pullout strength <sup>8</sup>	$\phi$	-	0.65									N/A									
Steel strength in shear	$V_{sa,deck}$	lb (kN)	1,155 (5.1)	1,155 (5.1)	2,315 (10.3)	2,115 (9.4)	2,115 (9.4)	2,820 (12.5)	2,095 (9.3)	N/A									N/A		
Steel strength in shear, seismic	$V_{sa,deck,eq}$	lb (kN)	960 (4.3)	960 (4.3)	1,930 (8.6)	1,475 (6.6)	1,475 (6.6)	1,965 (8.7)	1,675 (7.5)	N/A									N/A		
Reduction factor, steel strength in shear <sup>8</sup>	$\phi$	-	0.60									N/A									

For **SI**: 1 inch = 25.4 mm, 1 ft-lb = 1.356 N-m, 1 psi = 0.0069 N/mm<sup>2</sup> (MPa).  
 N/A = Not Applicable.

<sup>1</sup>Installation must comply with manufacturer's published installation instructions and details.

<sup>2</sup>Values for  $N_{p,deck}$  and  $N_{p,deck,cr}$  are for both, normal-weight or sand-lightweight concrete ( $f'_{c,min} = 3,000$  psi), and additional lightweight concrete reduction factors need not be applied. In addition, evaluation for the concrete breakout capacity in accordance with ACI 318-19 Section 17.6.2, is not required for anchors installed in the deck soffit (through underside).

<sup>3</sup>Values for  $N_{p,deck,eq}$  are applicable for seismic loading; see Section 4.1.8.2 of this report.

<sup>4</sup>For the calculation of  $N_{pn}$ , see Section 4.1.4 of this report; for all design cases  $\Psi_{c,P} = 1.0$ . The characteristic pullout strength for concrete compressive strengths greater than 3,000 psi for 1/4-inch-diameter anchors may be increased by multiplying the value in the table by  $(f'_c / 3,000)^{0.3}$  for psi or  $(f'_c / 17.2)^{0.3}$  for MPa. The characteristic pullout strength for concrete compressive strengths greater than 3,000 psi for 3/8-inch- to 3/4-inch-diameter anchors may be increased by multiplying the value in the table by  $(f'_c / 3,000)^{0.5}$  for psi or  $(f'_c / 17.2)^{0.5}$  for MPa.

<sup>5</sup>Shear loads for anchors installed through steel deck into concrete may be applied in any direction.

<sup>6</sup>Values of  $V_{sa,deck}$  and  $V_{sa,deck,eq}$  are for both, normal-weight or sand-lightweight concrete, and additional lightweight concrete reduction factors need not be applied. In addition, evaluation for the concrete breakout capacity in accordance with ACI 318-19 Section 17.7.2 and the pryout capacity in accordance with ACI 318-19 Section 17.7.3 are not required for anchors installed in the soffit (through underside).

<sup>7</sup>The minimum concrete member thickness,  $h_{min,deck,total}$ , is the minimum overall thickness of the concrete-filled steel deck (depth and topping thickness).

<sup>8</sup>The strength reduction factor applies when the load combinations from the 2024 IBC or ACI 318-19 are used and the requirements of ACI 318-19 Section 17.5.3 are met.

**TABLE 6—TENSION AND SHEAR DESIGN INFORMATION FOR HANGERMate+ ANCHORS IN THE SOFFIT (THROUGH THE UNDERSIDE) OF CONCRETE-FILLED STEEL DECK ASSEMBLIES<sup>1,2,3,4,5,6,9</sup>**

Anchor Property / Setting Information	Notation	Units	Nominal Anchor Size (inch)								
			<sup>1</sup> / <sub>4</sub>	<sup>3</sup> / <sub>8</sub>	<sup>3</sup> / <sub>8</sub>	<sup>3</sup> / <sub>8</sub>	<sup>3</sup> / <sub>8</sub>	<sup>1</sup> / <sub>2</sub>			
Anchor category	1, 2 or 3	-	1								
Coupler thread size (UNC)	-	in.	<sup>1</sup> / <sub>4</sub> -20	<sup>3</sup> / <sub>8</sub> -16						<sup>1</sup> / <sub>2</sub> -13	
Coupler head style	-	-	Int. Threaded	Int. Threaded	Ext. Thread		Int. Threaded	Int. Threaded			
Nominal anchor diameter (screw anchor body)	<i>d<sub>a</sub></i>	in. (mm)	0.250 (6.4)					0.375 (9.5)			
Minimum nominal embedment depth <sup>4</sup>	<i>h<sub>nom</sub></i>	in. (mm)	<sup>1</sup> / <sub>2</sub> (41)	<sup>1</sup> / <sub>2</sub> (41)	<sup>2</sup> / <sub>1</sub> (64)	<sup>1</sup> / <sub>2</sub> (41)	<sup>2</sup> / <sub>1</sub> (64)	2 (51)	<sup>2</sup> / <sub>1</sub> (64)	2 (51)	<sup>2</sup> / <sub>1</sub> (64)
Effective embedment	<i>h<sub>ef</sub></i>	in. (mm)	1.20 (30)	1.20 (30)	1.94 (49)	1.20 (30)	1.94 (49)	1.33 (33)	1.75 (44)	1.33 (33)	1.75 (44)
<b>HangerMate+ Anchors Installed into Minimum <sup>3</sup>/<sub>8</sub>-inch-wide Deck Flute (See Figure 6A)</b>											
Minimum concrete member thickness <sup>7</sup>	<i>h<sub>min,deck,total</sub></i>	in. (mm)	<sup>5</sup> / <sub>2</sub> (140)	<sup>5</sup> / <sub>2</sub> (140)	<sup>5</sup> / <sub>2</sub> (140)		<sup>5</sup> / <sub>2</sub> (140)		<sup>5</sup> / <sub>2</sub> (140)		
Pullout strength, uncracked concrete (3,000 psi)	<i>N<sub>p,deck,uncr</sub></i>	lb (kN)	1,430 (6.4)	1,430 (6.4)	2,555 (11.4)	1,430 (6.4)	2,555 (11.4)	2,275 (10.1)	2,655 (11.8)	2,275 (10.1)	2,655 (11.8)
Pullout strength, cracked concrete (3,000 psi)	<i>N<sub>p,deck,cr</sub></i>	lb (kN)	615 (2.7)	615 (2.7)	1,115 (5.0)	615 (2.7)	1,115 (5.0)	1,290 (5.1)	1,880 (8.4)	1,290 (5.1)	1,880 (8.4)
Pullout strength, seismic (3,000 psi)	<i>N<sub>p,deck,eq</sub></i>	lb (kN)	290 (1.3)	290 (1.3)	920 (4.1)	290 (1.3)	920 (4.1)	890 (4.0)	1,570 (7.0)	890 (4.0)	1,570 (7.0)
Reduction factor, pullout strength <sup>8</sup>	<i>φ</i>	-	0.65								
Steel strength in shear	<i>V<sub>sa,deck</sub></i>	lb (kN)	1,205 (5.4)	1,205 (5.4)	1,205 (5.4)		1,360 (6.0)		2,740 (11.0)		
Steel strength in shear, seismic	<i>V<sub>sa,deck,eq</sub></i>	lb (kN)	615 (2.7)	615 (2.7)	615 (2.7)		965 (4.3)		1,040 (4.6)		
Reduction factor, steel strength in shear <sup>8</sup>	<i>φ</i>	-	0.60								
<b>HangerMate+ Anchors Installed into Minimum <sup>1</sup>/<sub>4</sub>-inch-wide Deck Flute (See Figure 6B)</b>											
Minimum concrete member thickness <sup>7</sup>	<i>h<sub>min,deck,total</sub></i>	in. (mm)	4 (102)	4 (102)	4 (102)		4 (102)		4 (102)		
Pullout strength, uncracked concrete (3,000 psi)	<i>N<sub>p,deck,uncr</sub></i>	lb (kN)	1,430 (6.4)	1,430 (6.4)	2,075 (9.2)	1,430 (6.4)	2,075 (9.2)	1,440 (6.4)	2,135 (9.5)	1,440 (6.4)	2,135 (9.5)
Pullout strength, cracked concrete (3,000 psi)	<i>N<sub>p,deck,cr</sub></i>	lb (kN)	615 (2.7)	615 (2.7)	910 (4.0)	615 (2.7)	910 (4.0)	815 (3.6)	1,510 (6.7)	815 (3.6)	1,510 (6.7)
Pullout strength, seismic (3,000 psi)	<i>N<sub>p,deck,eq</sub></i>	lb (kN)	290 (1.3)	290 (1.3)	750 (3.3)	290 (1.3)	750 (3.3)	565 (2.5)	1,260 (5.6)	565 (2.5)	1,260 (5.6)
Reduction factor, pullout strength <sup>8</sup>	<i>φ</i>	-	0.65								
Steel strength in shear	<i>V<sub>sa,deck</sub></i>	lb (kN)	815 (3.6)	815 (3.6)	815 (3.6)		1,110 (4.9)		1,110 (4.9)		
Steel strength in shear, seismic	<i>V<sub>sa,deck,eq</sub></i>	lb (kN)	415 (1.8)	415 (1.8)	415 (1.8)		790 (3.5)		465 (2.1)		
Reduction factor, steel strength in shear <sup>8</sup>	<i>φ</i>	-	0.60								

For **SI**: 1 inch = 25.4 mm, 1 ft-lb = 1.356 N-m, 1 psi = 0.0069 N/mm<sup>2</sup> (MPa).

<sup>1</sup>Installation must comply with manufacturer's published installation instructions and details.

<sup>2</sup>Values for *N<sub>p,deck</sub>* and *N<sub>p,deck,cr</sub>* are for both, normal-weight or sand-lightweight concrete (*f<sub>c,min</sub>* = 3,000 psi), and additional lightweight concrete reduction factors need not be applied. In addition, evaluation for the concrete breakout capacity in accordance with ACI 318-19 Section 17.6.2 is not required for anchors installed in the deck soffit (through underside).

<sup>3</sup>Values for *N<sub>p,deck,eq</sub>* are applicable for seismic loading; see Section 4.1.8.2 of this report.

<sup>4</sup>For the calculation of *N<sub>p</sub>*, see Section 4.1.4 of this report; for all design cases *ψ<sub>c,p</sub>* = 1.0. The characteristic pullout strength for concrete compressive strengths greater than 3,000 psi for <sup>1</sup>/<sub>4</sub>-inch-diameter anchors (screw anchor body diameter) may be increased by multiplying the value in the table by (*f<sub>c</sub>* / 3,000)<sup>0.3</sup> for psi or (*f<sub>c</sub>* / 17.2)<sup>0.3</sup> for MPa. The characteristic pullout strength for concrete compressive strengths greater than 3,000 psi for <sup>3</sup>/<sub>8</sub>-inch-diameter anchors (screw anchor body diameter) may be increased by multiplying the value in the table by (*f<sub>c</sub>* / 3,000)<sup>0.5</sup> for psi or (*f<sub>c</sub>* / 17.2)<sup>0.5</sup> for MPa.

<sup>5</sup>Shear loads for anchors installed through steel deck into concrete may be applied in any direction.

<sup>6</sup>Values of *V<sub>sa,deck</sub>* and *V<sub>sa,deck,eq</sub>* are for both, normal-weight or sand-lightweight concrete, and additional lightweight concrete reduction factors need not be applied. In addition, evaluation for the concrete breakout capacity in accordance with ACI 318-19 Section 17.7.2 and the pryout capacity in accordance with ACI 318-19 Section 17.7.3 are not required for anchors installed in the soffit (through underside).

<sup>7</sup>The minimum concrete member thickness, *h<sub>min,deck,total</sub>*, is the minimum overall thickness of the concrete-filled steel deck (depth and topping thickness).

<sup>8</sup>The strength reduction factor applies when the load combinations from the 2024 IBC or ACI 318-19 are used and the requirements of ACI 318-19 Section 17.5.3 are met.

<sup>9</sup>HangerMate+ shear values are for threaded rod or steel inserts with and ultimate strength, *F<sub>u</sub>* ≥ 125 ksi; threaded rod or steel inserts with an *F<sub>u</sub>* less than 125 ksi are allowed provided the steel strength shear values are multiplied by the ratio of *F<sub>u</sub>* (ksi) of the steel insert and 125 ksi.

TABLE 7—EXAMPLE ALLOWABLE STRESS DESIGN VALUES FOR ILLUSTRATIVE PURPOSES<sup>1,2,3,4,5,6,7,8,9</sup>

Anchor	Nominal Anchor Diameter, (in.)	Nominal Embedment Depth, (in.)	Effective Embedment, (in.)	Allowable Tension Load, (lbs)
Screw-Bolt+	1/4 (Hex or Flat Head)	1 <sup>5</sup> / <sub>8</sub>	1.20	780
		2	1.52	990
		2 <sup>1</sup> / <sub>2</sub>	1.94	1,425
	3/8 (Hex or Flat Head)	2	1.33	1,010
		2 <sup>1</sup> / <sub>2</sub>	1.75	1,220
		3 <sup>1</sup> / <sub>4</sub>	2.39	1,945
	1/2 (Hex or Flat Head)	2 <sup>1</sup> / <sub>2</sub>	1.75	1,525
		3	2.17	1,685
		3 <sup>1</sup> / <sub>2</sub>	2.60	2,210
		4 <sup>1</sup> / <sub>4</sub>	3.23	3,060
	5/8 (Hex Head)	3 <sup>1</sup> / <sub>4</sub>	2.24	2,210
		3 <sup>5</sup> / <sub>8</sub>	2.56	2,160
		4	2.88	2,575
		4 <sup>1</sup> / <sub>2</sub>	3.30	3,160
	3/4 (Hex Head)	5	3.73	3,795
4 <sup>1</sup> / <sub>4</sub>		3.08	3,205	
5 <sup>1</sup> / <sub>4</sub>		3.93	4,105	
6 <sup>1</sup> / <sub>4</sub>		4.78	5,510	
7 <sup>1</sup> / <sub>4</sub>		5.63	7,040	
HangerMate+	1/4 (1/4-20 coupler head)	1 <sup>5</sup> / <sub>8</sub>	1.20	780
		2 <sup>1</sup> / <sub>2</sub>	1.94	1,425
	1/4 (3/8-16 coupler head)	1 <sup>5</sup> / <sub>8</sub>	1.20	780
		2 <sup>1</sup> / <sub>2</sub>	1.94	1,425
	3/8 (3/8-16 coupler head)	2	1.33	1,010
		2 <sup>1</sup> / <sub>2</sub>	1.75	1,220
	3/8 (1/2-13 coupler head)	2	1.33	1,010
		2 <sup>1</sup> / <sub>2</sub>	1.75	1,220

For SI: 1 inch = 25.4 mm; 1 lbf = 0.0044 kN.

Illustrative Allowable Stress Design Values in Table 7 are applicable only when the following design assumptions are followed:

<sup>1</sup>Single anchor with static tension load only.

<sup>2</sup>Concrete determined to remain uncracked for the life of the anchorage.

<sup>3</sup>Load combinations from ACI 318-19 Section 5.3 (no seismic loading).

<sup>4</sup>30% dead load and 70% live load, controlling load combination: 1.2D + 1.6L.

<sup>5</sup>Calculated of weighted average for α = 1.2(0.3) + 1.6(0.7) = 1.48.

<sup>6</sup>f<sub>c</sub> = 2,500 psi (normal weight concrete).

<sup>7</sup>C<sub>a1</sub> = C<sub>a2</sub> ≥ C<sub>ac</sub>.

<sup>8</sup>h ≥ h<sub>min</sub>.

<sup>9</sup>Values are for Condition B; supplementary reinforcement in accordance with ACI 318-19 Section 17.5.3 is not provided.

Calculation in accordance with ACI 318-19 Chapter 17 and this report:	ACI 318-19 Code Ref.	Report Ref.
<p>Given: Calculate the factored strength design resistance in tension, <math>\phi N_n</math>, and the allowable stress design value, <math>T_{allowable, ASD}</math>, for a 1/2-inch diameter Screw-Bolt+ anchor with 3-inch nominal embedment assuming the given conditions in Table 7.</p> <p>Step 1. Calculate steel strength of a single anchor in tension:  <math>\phi N_{sa} = (0.65)(20,475) = 13,309 \text{ lbs.}</math></p>	17.6.1.2	Table 3A §4.1.2
<p>Step 2. Calculate concrete breakout strength of a single anchor in tension:  <math display="block">\phi N_{cb} = \phi \frac{A_{Nc}}{A_{Nc0}} \psi_{ed,N} \psi_{c,N} \psi_{cp,N} N_b</math> <math display="block">N_b = k_c l_a \sqrt{f'_c} (h_{ef})^{1.5}</math> <math display="block">N_b = (24)(1.0) \sqrt{2,500} (2.17)^{1.5} = 3,836 \text{ lbs.}</math> <math display="block">\phi N_{cb} = (0.65) \frac{(42.4)}{(42.4)} (1.0)(1.0)(1.0)(3,836) = 2,493 \text{ lbs.}</math></p>	17.6.2.1	Table 3A §4.1.3
<p>Step 3. Calculate pullout strength:  <math>\phi N_{pn} = \phi N_{p,uncr} \psi_{c,P}</math>  <math>\phi N_{pn} = n/a</math> (pullout strength does not control per reported design values)</p>	17.6.2.2	Table 3A
<p>Step 4. Determine controlling resistance strength in tension:  <math>\phi N_n = \min[\phi N_{sa}, \phi N_{cb}, \phi N_{pn}] = \phi N_{cb} = 2,493 \text{ lbs.}</math></p>	17.6.3.2.1	Table 3A §4.1.4
<p>Step 5. Calculate allowable stress design conversion factor for loading condition:                      Controlling load combination: 1.2D + 1.6L  <math>\alpha = 1.2(30\%) + 1.6(70\%) = 1.48</math></p>	17.5.1.3	
<p>Step 6. Calculate allowable stress design value  <math display="block">T_{allowable, ASD} = \frac{\phi N_n}{\alpha} = \frac{2,493}{1.48} = 1,685 \text{ lbs.}</math></p>	5.2	§4.2

FIGURE 7—EXAMPLE STRENGTH DESIGN CALCULATION INCLUDING ASD CONVERSION, FOR ILLUSTRATIVE PURPOSES

**TABLE 8— APPLICABLE SECTIONS OF THE IBC UNDER EACH EDITION OF THE IBC**

2024 IBC	2021 IBC	2018 IBC	2015 IBC
Section 1605.1		Section 1605.2 or 1605.3	
Section 1705.1.1 and Table 1705.3			
Section 1901.3			
Sections 1903 and 1905			
Section 1905.7	Section 1905.1.8		

**TABLE 9— APPLICABLE SECTIONS OF ACI 318 UNDER EACH EDITION OF THE IBC**

2024 IBC	2021 IBC	2018 IBC	2015 IBC
<b>ACI 318-19</b>		<b>ACI 318-14</b>	
2.3		2.3	
5.3		5.3	
Chapter 17		Chapter 17	
17.3.1		17.2.7	
17.5.1.2		17.3.1	
17.5.1.3		17.3.1.1	
17.5.3		17.3.3	
17.6		17.4	
17.6.1		17.4.1	
17.6.1.2		17.4.1.2	
17.6.2		17.4.2	
17.6.2.1		17.4.2.1	
17.6.2.2		17.4.2.2	
17.6.2.5.1(a)		17.4.2.6	
17.6.3		17.4.3	
17.6.3.1		17.4.3.1	
17.6.3.2.1		17.4.3.2	
17.6.3.3		17.4.3.6	
17.7		17.5	
17.7.1		17.5.1	
17.7.1.2		17.5.1.2	
Eq. 17.7.1.2b		Eq. 17.5.1.2b	
17.7.2		17.5.2	
17.7.2.2.1		17.5.2.2	
17.7.3		17.5.3	
17.8		17.6	
17.9.2		17.7.1 and 17.7.3	
17.9.4		17.7.5	
17.9.5		17.7.6	
17.10		17.2.3	
17.10.3		17.2.3.3	
17.10.4, 17.10.5, 17.10.6, 17.10.7		17.2.3.4, 17.2.3.5, 17.2.3.6, 17.2.3.7	

**DIVISION: 03 00 00—CONCRETE**

**Section: 03 16 00—Concrete Anchors**

**DIVISION: 05 00 00—METALS**

**Section: 05 05 19—Post-Installed Concrete Anchors**

**REPORT HOLDER:**

DEWALT

**EVALUATION SUBJECT:**

**SCREW-BOLT+™ ANCHORS AND HANGER-MATE®+ ROD HANGER SCREW ANCHORS IN CRACKED AND UNCRACKED CONCRETE (DEWALT)**

## 1.0 REPORT PURPOSE AND SCOPE

### Purpose:

The purpose of this evaluation report supplement is to indicate that Screw-Bolt+ Screw Anchors and Hangermate+ Rod Hanger Screw Anchors in cracked and uncracked concrete, described in ICC-ES evaluation report [ESR-3889](#), have also been evaluated for compliance with the codes noted below as adopted by Los Angeles Department of Building and Safety (LADBS).

### Applicable code editions:

- 2023 *City of Los Angeles Building Code* ([LABC](#))
- 2023 *City of Los Angeles Residential Code* ([LARC](#))

## 2.0 CONCLUSIONS

The Screw-Bolt+ Screw Anchors and Hangermate+ Rod Hanger Screw Anchors in cracked and uncracked concrete, described in Sections 2.0 through 7.0 of the evaluation report [ESR-3889](#), comply with LABC Chapter 19, and LARC, and are subjected to the conditions of use described in this report.

## 3.0 CONDITIONS OF USE

The Screw-Bolt+ and Hangermate+ anchors described in this evaluation report supplement must comply with all of the following conditions:

- All applicable sections in the evaluation report [ESR-3889](#).
- The design, installation, conditions of use and labeling of the anchors are in accordance with the 2021 *International Building Code*® (IBC) provisions noted in the evaluation report [ESR-3889](#).
- The design, installation and inspection are in accordance with additional requirements of LABC Chapters 16 and 17, as applicable.
- Under the LARC, an engineered design in accordance with LARC Section R301.1.3 must be submitted.
- The allowable and strength design values listed in the evaluation report and tables are for the connection of the anchors to the concrete. The connection between the anchors and the connected members shall be checked for capacity (which may govern).
- For use in wall anchorage assemblies to flexible diaphragm applications, anchors shall be designed per the requirements of City of Los Angeles Information Bulletin P/BC 2023-071.

This supplement expires concurrently with the evaluation report, reissued November 2024 and revised February 2026.

**DIVISION: 03 00 00—CONCRETE**  
**Section: 03 16 00—Concrete Anchors**

**DIVISION: 05 00 00—METALS**  
**Section: 05 05 19—Post-Installed Concrete Anchors**

**REPORT HOLDER:**

DEWALT

**EVALUATION SUBJECT:**

**SCREW-BOLT+™ ANCHORS AND HANGERMATE®+ ROD HANGER SCREW ANCHORS IN CRACKED AND UNCRACKED CONCRETE (DEWALT)**

**1.0 REPORT PURPOSE AND SCOPE**

**Purpose:**

The purpose of this evaluation report supplement is to indicate that Screw-Bolt+ Screw Anchors and Hangermate+ Rod Hanger Screw Anchors in Cracked and Uncracked Concrete, described in ICC-ES evaluation report [ESR-3889](#), have also been evaluated for compliance with the codes noted below:

**Compliance with the following codes:**

- 2023 Florida Building Code—Building
- 2023 Florida Building Code—Residential

**2.0 CONCLUSIONS**

The Screw-Bolt+ Screw Anchors and Hangermate+ Rod Hanger Screw Anchors in Cracked and Uncracked Concrete described in Sections 2.0 through 7.0 of the ICC-ES evaluation report [ESR-3889](#) comply with the *Florida Building Code—Building* and the *Florida Building Code—Residential*. The design requirements must be in accordance with the *Florida Building Code—Building* or the *Florida Building Code—Residential*, as applicable. The installation requirements noted in ICC-ES evaluation report [ESR-3889](#) for the 2021 *International Building Code*® meet the requirements of the *Florida Building Code—Building* or the *Florida Building Code—Residential*.

Use of the Screw-Bolt+ Screw Anchors and Hangermate+ Rod Hanger Screw Anchors in cracked and uncracked concrete has also been found to be in compliance with the High-Velocity Hurricane Zone provisions of the *Florida Building Code—Building* and the *Florida Building Code—Residential* with the following conditions:

- a) For connections subject to uplift, the connection must be designed for no less than 700 pounds (3114 N).

For products falling under Florida Rule 61G20-3, verification that the report holder's quality-assurance program is audited by a quality-assurance entity approved by the Florida Building Commission for the type of inspections being conducted is the responsibility of an approved validation entity (or the code official, when the report holder does not possess an approval by the Commission).

This supplement expires concurrently with the evaluation report, reissued November 2025 and revised February 2026.