

HIGH PERFORMANCE BUILDING

Contractor's handbook

**A contractor's guide to Dow construction
products and procedures**

DOW

®

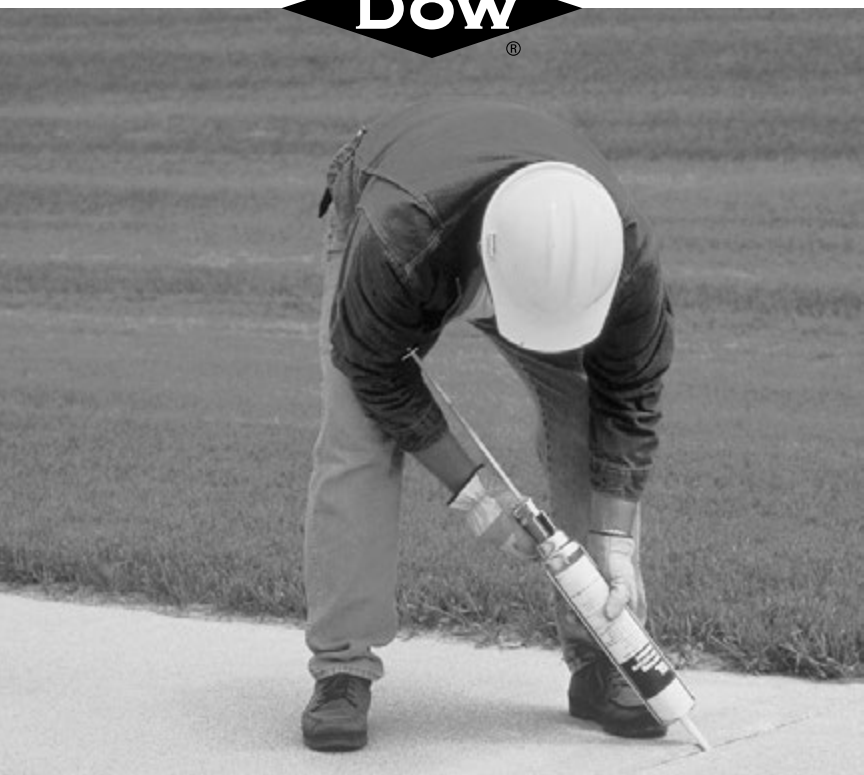

Table of contents

Introduction

Products2

Sealants

Requirement estimator.....3
Selector guide.....4
Joint movement and design6
Primer selection7
Surface preparation and sealant application7
Cold weather sealant application suggestions8
Sealing to air barrier organic membranes.....9
Equipment cleaning 10
Field adhesion testing 10

DOWSIL™ AllGuard Silicone Elastomeric Coating

Substrate compatibility 12
Compatibility with DOWSIL™ products..... 12
Typical properties..... 12
Temperature and humidity 12
Priming..... 12
Estimated application rate 13
Coating..... 13
Adhesion test procedure..... 13

DOWSIL™ 123 Silicone Seal

Recommended joint design..... 14
Preformed custom designs..... 14
Installation..... 14
Adhesion test procedure..... 16
Test area repair..... 16

Additional information 17

Glossary of terms20

This guide is intended to provide general information about using DOWSIL™ weathersealing and structural sealant products. From product selection and joint design to surface preparation and product application, this guide will familiarize you with the basic installation procedures necessary to optimize silicone's performance advantages.

Helpful estimating guides are included as well. And, because this is a general guide, each section includes references to more detailed procedure manuals available from Dow (see page 18). Additional information on specific products and procedures is available via the Dow website at dow.com/construction.

Products covered in this guide include:

Primers and cleaners

DOWSIL™ 1200 OS Primer
DOWSIL™ Primer-C OS
DOWSIL™ Construction Primer P

Sealants

DOWSIL™ 121 Structural Glazing Sealant
DOWSIL™ 756 SMS Building Sealant
DOWSIL™ 758 Silicone Weather Barrier Sealant
DOWSIL™ 790 Silicone Building Sealant
DOWSIL™ 791 Silicone Weatherproofing Sealant
DOWSIL™ 795 Silicone Building Sealant
DOWSIL™ 995 Silicone Structural Sealant
DOWSIL™ 999A Building and Glazing Sealant
DOWSIL™ Contractors Concrete Sealant (CCS)
DOWSIL™ Contractors Weatherproofing Sealant (CWS)
DOWSIL™ FC Parking Structure Sealant
DOWSIL™ SL Parking Structure Sealant
DOWSIL™ NS Parking Structure Sealant

Preformed silicone sealant

DOWSIL™ 123 Silicone Seal

Weatherproofing coating

DOWSIL™ AllGuard Silicone Elastomeric Coating

Requirement estimator

Joint size D x W, inches	Linear feet sealed				
	1 gallon	10.3-fluid ounce cartridge	20-fluid ounce sausage	2-gallon pail	4.5-gallon pail
3/16 x 1/4	411	33	64	821	1848
3/16 x 3/8	274	22	43	548	1232
3/16 x 1/2	205	16	32	411	924
3/16 x 5/8	164	13	26	329	739
3/16 x 3/4	137	11	21	274	616
1/4 x 1/4	308	25	48	616	1386
1/4 x 3/8	205	16	32	411	924
1/4 x 1/2	154	12	24	308	693
1/4 x 5/8	123	10	19	246	554
1/4 x 3/4	103	8.3	16	205	462
1/4 x 1	77	6.2	12	154	346
3/8 x 3/8	137	11	21	274	616
3/8 x 1/2	103	8.3	16	205	462
3/8 x 5/8	82	6.6	13	164	370
3/8 x 3/4	68	5.5	11	137	308
3/8 x 1	51	4.1	7.9	103	231
3/8 x 1.5	34	2.7	5.3	68	154
3/8 x 2	25	2.0	3.9	51	115
3/8 x 3	17	1.4	2.6	34	77
1/2 x 1/2	77	6.2	12	154	346
1/2 x 5/8	62	5.0	9.7	123	277
1/2 x 3/4	51	4.1	8.0	103	231
1/2 x 1	39	3.1	6.1	77	173
1/2 x 1.5	25	2.0	3.9	52	115
1/2 x 2	19	1.5	3.0	38	86
1/2 x 3	12	1.0	1.9	26	58

Note: Actual volume of sealant used will depend on factors such as joint design, backer rod placement, tooling and waste at the job site.

Volume equivalents

25 cartridges = one 2-gallon (7.6-liter) pail

56 cartridges = one 4.5-gallon (17-liter) pail

Six 20-oz sausages = 1 gallon, less 8 oz

Selector guide

Product/ Recommended application	Neutral-cure system	Durometer, Shore A, points	Modulus	Joint movement, %	Tooling time, minutes	All-temperature gunnability	Warranty term, years
DOWSIL™ 121 Structural Glazing Sealant	Yes, 2-part	30	Med.	±25	15-45	Yes	20
DOWSIL™ 123 Silicone Seal	N/A	25	Ultra- low	+200/ -75	N/A	N/A	10
DOWSIL™ 756 SMS Building Sealant	Yes, 1-part	35	Med.	±50	30	Yes	20
DOWSIL™ 758 Silicone Weather Barrier Sealant	Yes, 1-part	45	Med.	±25	15	Yes	20
DOWSIL™ 790 Silicone Building Sealant	Yes, 1-part	15	Ultra- low	+100/ -50	10-20	Yes	20
DOWSIL™ 791 Silicone Weatherproofing Sealant	Yes, 1-part	30	Med.	±50	15	Yes	20
DOWSIL™ 795 Silicone Building Sealant	Yes, 1-part	35	Med.	±50	20-30	Yes	20
DOWSIL™ 995 Silicone Structural Sealant	Yes, 1-part	40	Med.	±50	10-20	Yes	20
DOWSIL™ 999A Building and Glazing Sealant	No, 1-part	25	Med.	±25	5-10	Yes	10
DOWSIL™ Contractors Concrete Sealant (CCS)	Yes, 1-part	15	Low	±50	10-20	Yes	5
DOWSIL™ Contractors Weatherproofing Sealant (CWS)	Yes, 1-part	35	Med.	±40	>60	Yes	5
DOWSIL™ AllGuard Silicone Elastomeric Coating	Yes, 1-part	N/A	N/A	N/A	N/A	N/A	10
DOWSIL™ FC Parking Structure Sealant	Yes, 2-part	60 Shore 00	Ultra- low	+100/ -50	N/A	Yes	5
DOWSIL™ SL Parking Structure Sealant	Yes, 1-part	50 Shore 00	Ultra- low	+100/ -50	N/A	Yes	5
DOWSIL™ NS Parking Structure Sealant	Yes, 1-part	15	Low	+100/ -50	10-20	Yes	5

Key: N/A — Not applicable

Selector guide

Primer required							Colors available	Packaging
Fluoropolymer paint	Silicone polyester paint	Anodized aluminum	Alodine-treated aluminum	Granite	Limestone	Concrete		
C OS	C OS	1200 OS	1200 OS	N/A	N/A	N/A	Black, Dark grey	400 mL fill (2*200 mL) Cartridges
N/A	N/A	N/A	N/A	N/A	N/A	N/A	11 + Custom	100-foot Rolls
Test	Test	No	No	No	1200 OS/P	Test	12 + Custom	Sausages, Pails
No	No	No	No	N/A	N/A	N/A	White	Sausages
Test	1200 OS	1200 OS	Test	No	Test	No	12 + Custom	Cartridges, Sausages, Pails
No	No	No	No	Test	Test	1200 OS/P	6	Cartridges, Sausages
C OS	No	No	No	1200 OS/P	P	P	14 + Custom	Cartridges, Sausages, Pails
No	No	No*	No*	N/A	N/A	N/A	Black Gray White	Cartridges, Sausages, Pails
1200 OS	No	1200 OS	1200 OS	N/A	N/A	N/A	5 + Clear + Custom	Cartridges, Pails
Test	1200 OS	1200 OS	Test	No	No	No	7 + Custom	Cartridges, Sausages, Pails
C OS	No	No	No	1200 OS/P	P	P	22 + 18 Special + Custom	Cartridges, Sausages, Pails
N/A	N/A	N/A	N/A	Required			55 + Custom	Pails
N/A	N/A	Yes	Yes	N/A	N/A	1200 OS	Gray	Sausages
N/A	N/A	N/A	N/A	N/A	N/A	No	Dark gray	Cartridges, Pails
1200 OS	1200 OS	1200 OS	1200 OS	No	1200 OS	No	Gray	Cartridges, Pails

Key: N/A – Not applicable
 1200 OS – DOWSIL™ 1200 OS Primer
 P – DOWSIL™ Construction Primer P
 C OS – DOWSIL™ Primer-C OS

*Weatherseals

Joint movement and design

Joint design for proper sealant movement

1. Dimensions C and A must be at least 1/4"
2. Ratio of A:B should be 2:1 minimum
3. Joint surface tooled concave
4. Dimension B suggested maximum = 3/8"
Never exceed 1/2"
5. Dimension A maximum = 4" for DOWSIL™ 756 SMS Building Sealant, DOWSIL™ 790 Silicone Building Sealant, DOWSIL™ 791 Silicone Weatherproofing Sealant, and DOWSIL™ 795 Silicone Building Sealant

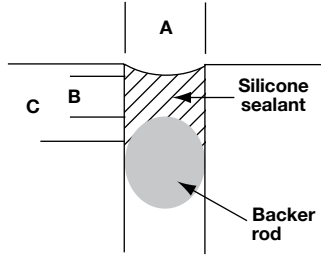

For structural applications using DOWSIL™ 121 Structural Glazing Sealant, DOWSIL™ 795 Sealant, and DOWSIL™ 995 Silicone Structural Sealant, please refer to the *Dow Americas Technical Manual*, Form No. 62-1112.

Joint movement indicator

Determination of joint movement is critical for designing and constructing effective joints. A joint movement indicator is a useful tool designed to gauge the amount of movement a joint experiences. Dow has developed an easy-to-use device that lets you test virtually any sealed joint for expansion and compression and record such movement over any period of time. Additional information concerning the joint movement indicator is available in *Using the Dow Joint Movement Indicator*, Form No. 61-637.

Other joint design considerations

- A minimum of 1/4" sealant substrate bond is necessary to ensure adequate adhesion.
- A minimum 1/4" wide weatherseal joint is required for proper joint performance.
- Silicone sealant should not be installed as deep as urethanes.
- One-part silicone sealants require atmospheric moisture to fully cure.
- A backer rod ~25 percent larger than the joint opening is recommended for weathersealing. Sizing differs with open- and closed-cell rods.

- For EIFS at window areas, use either DOWSIL™ 791 Silicone Weatherproofing Sealant or DOWSIL™ 795 Silicone Building Sealant with closed-cell backer rod. For other EIFS-to-EIFS joints, use DOWSIL™ 790 Silicone Building Sealant with closed-cell or soft-type backer rod.
- A thin sealant joint (1/4" ± 1/8" depth) will accommodate more movement than a thick joint. Sealants are designed to deliver optimum performance when the joints are shaped like an hourglass.
- As the sealant joint width becomes larger than 1", the depth should be held at approximately 3/8 - 1/2".

Primer selection

- DOWSIL™ 1200 OS Primer – The most commonly recommended product for a wide variety of construction substrates. Available in clear.
- DOWSIL™ Construction Primer P – A one-part, film-forming primer for use with DOWSIL™ sealants on porous and cementitious surfaces to promote adhesion. (DOWSIL™ Construction Primer P should not be used with DOWSIL™ 790 Silicone Building Sealant, DOWSIL™ Contractors Concrete Sealant or DOWSIL™ Parking Structure Sealants.)

Approximate primer coverage rate (lineal ft/gal)

	DOWSIL™ 1200 OS Primer	DOWSIL™ Construction Primer P
Porous substrates	5,000	2,000
Non-porous substrates	10,000	N/A

Surface preparation and sealant application

The five basic steps for proper joint preparation and sealant application:

1. **Clean** – Joint surfaces must be clean, dry, dust-free and frost-free.

In remedial applications, cut away the old sealant as close to the joint edges as possible. Clean by abrading with a wire brush, grinding, saw cutting or solvent cleaning. Blow out dust and other debris with **oil-free** compressed air (90 psi recommended with no moisture or oil in air).

For nonporous surfaces:

- Use a cloth with cleaning solvent such as isopropyl alcohol (IPA) to clean (Note: Do not use alcohol-type cleaners with DOWSIL™ 790 Silicone Building Sealant, DOWSIL™ Contractors Concrete Sealant or DOWSIL™ Parking Structure Sealants.)
- Wipe with a second, dry cloth

For porous surfaces:

- Use a cloth dampened with xylene
 - Wipe to remove fingerprints
 - Wipe with second, dry cloth
2. **Prime** – If necessary, apply primer to the clean surfaces.
 - Wear rubber gloves when handling primer
 - Mask sides of joint to keep primer off the face of substrates
 - Allow the primer to dry before applying sealant
 - On concrete, apply the primer in both directions to coat all irregularities and valleys
 3. **Pack** – Install backer rod or bond breaker as required.
 - Place backer rod after primer has dried
 - Do not use fingers to install backer rod; place using a roller or other tool
 - Place at a uniform depth
 - Use open-cell polyurethane backer rod with DOWSIL™ 790 Silicone Building Sealant and DOWSIL™ Contractors Concrete Sealant against painted or metal surfaces to promote cure from both sides of the joint
 4. **Shoot** – Apply sealant by pushing the bead into the joint cavity.
 - Mask sides of joint
 - Start at the bottom of the joint and work up
 5. **Tool** – Use **dry** tooling techniques to strike a flush joint and make certain the sealant has the proper configuration and fully contacts the joint walls.
 - Tool in both directions with a spatula
 - No wet tooling

Detailed cleaning procedures are outlined in the *Dow Americas Technical Manual*, Form No. 62-1112.

Cold weather sealant application suggestions

Silicone sealants can be applied in subfreezing temperatures, provided the substrate is frost- and moisture-free. Although cure will be slower in colder temperatures, adhesion will be acceptable. DOWSIL™ 121 Structural Glazing Sealant, DOWSIL™ 795 Silicone Building Sealant, DOWSIL™ 995 Silicone Structural Sealant, DOWSIL™ 756 SMS Building Sealant, DOWSIL™ 791 Silicone Weatherproofing Sealant and DOWSIL™ 790 Silicone Building Sealant have wider installation temperature ranges and are more suitable for use in cold temperatures than organic sealant technologies. All of these DOWSIL™ sealants can be applied to substrates within a temperature range of -29 to 49°C (-20 to 120°F). If lower or higher

application temperatures are needed, please contact Dow to discuss appropriate sealants. IPA and MEK are soluble in water and may be more appropriate for winter cleaning because they help in removing condensation and frost. Xylene and toluene are not soluble in water and may be better suited for warm-weather cleaning. All surfaces must be free of moisture, condensation, morning dew and frost conditions prior to installation. (Note: Do not use alcohol-type cleaners with DOWSIL™ 790 Silicone Building Sealant, DOWSIL™ Contractors Concrete Sealant or DOWSIL™ Parking Structure Sealants.)

At colder temperatures (below 4°C/40°F), substrates should be inspected for frost, which must be removed. Daily inspections are strongly recommended to review these cold weather conditions and correct with proper cleaning.

Maintain a log, reviewing and recording low-temperature start-up conditions. Please allow longer curing time prior to performing field adhesion testing. Contact your Dow Application Sales Engineer for assistance.

Sealing to air barrier organic membranes

Polyethylene-backed bitumen-based membranes are commonly used as air barriers within exterior walls. Sealant materials are expected to adhere to the polyethylene backing to provide a watertight barrier at window and door openings along with various transition points within the wall. Polyethylene is known in the sealant industry as a bond breaker, and thus the reliability of the long-term bond of the sealant is unpredictable. The best option that can be offered is the use of DOWSIL™ 758 Silicone Weather Barrier Sealant. With project-specific testing, other sealants may be suitable for the application.

Many flashings and fluid-applied membranes will discolor light sealants. Dow is available to test compatibility of flashing and sealant upon request. For any asphaltic or bitumen-based flashing material, Dow recommends use of a dark-colored sealant or installation of the sealant in a final nonvisible location. Typically, sealant performance is not affected by the discoloration on the sealant.

Cleaning procedures for flashing substrates

Peel-and-stick and spun-bound polyolefin substrates are unique surfaces to bond to, but they must be clean in order to achieve sealant adhesion. However, adhesion to these substrates may be negatively affected if they are “over-cleaned,” burnished or polished. Dow therefore recommends a light two-rag wipe method using isopropyl alcohol (IPA) for cleaning these surfaces. Utilize clean, soft, absorbent, lint-free cloths for the cleaning. The “two-cloth” cleaning method consists of a solvent wipe followed by a dry cloth wipe.

1. If there is significant dirt or debris visible on the membrane surface, lightly brush this off using a soft brush.
2. Pour or dispense an acceptable cleaning-grade solvent onto the cloth. A plastic (solvent-resistant) squeeze bottle works best for organic cleaning solvents. Do not dip the cloth into the container of solvent, as this will contaminate the cleaning agent.
3. Lightly wipe the membrane surface to remove contaminants. Check the cloth to see if it has picked up contaminants. Rotate the cloth to a clean area and re-wipe until no additional dirt is picked up.
4. Immediately wipe the cleaned area with a separate clean, dry cloth.

The IPA must be removed with the dry cloth before the solvent evaporates or the cleaning will be less effective. Allow the IPA to “flash” or dry prior to applying primer or sealant. Drying time depends on environmental conditions, but typically on a membrane substrate, allowing 5-10 minutes for the IPA to flash off is sufficient.

DOWSIL™ 758 Silicone Weather Barrier Sealant

DOWSIL™ 758 Silicone Weather Barrier Sealant is generally intended for use against polymeric flashing materials, which should be cleaned according to the procedures on page 9. Generally, DOWSIL™ 758 Silicone Weather Barrier Sealant does not require use of a primer. Should a primer be found to be necessary or to enhance adhesion, please follow the primer procedures on page 5.

NOTE: When field adhesion testing with DOWSIL™ 758 Silicone Weather Barrier Sealant, please be aware of its unique behavior. No sealant should be pulled on at high speed, but DOWSIL™ 758 Silicone Weather Barrier Sealant in particular should be pulled slowly at 90 degrees in order to avoid a false negative result.

Equipment cleaning

Avoid using solvents for cleaning sealant application guns. Use an appropriate cleaning product, such as DOWSIL™ OS-2 Silicone Cleaner and Solvent. Refer to equipment manufacturer recommendations for suitable cleaning products.

Field adhesion testing

To ensure the best performance of DOWSIL™ brand silicone sealants, a field adhesion test (also called a hand pull test) can be performed to verify proper sealant installation. Failure of this test may indicate improper joint cleaning, priming or sealant application.

Field adhesion rest – Weatherseal joint

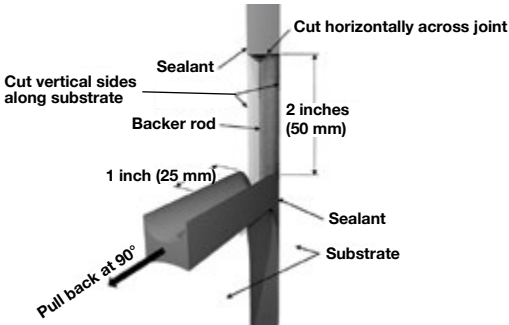

Test criteria

DOWSIL™ sealant	Adhesion requirement
DOWSIL™ 121 Structural Glazing Sealant	Pull tab until it breaks without bond loss
DOWSIL™ 756 SMS Building Sealant	Pull tab 1.5" (150% extension) without bond loss
DOWSIL™ 758 Silicone Weather Barrier Sealant	Pull tab 2" (200% extension) without bond loss
DOWSIL™ 790 Silicone Building Sealant	Pull tab 3" (300% extension) without bond loss
DOWSIL™ 791 Silicone Weatherproofing Sealant	Pull tab 1.5" (150% extension) without bond loss
DOWSIL™ 795 Silicone Building Sealant	Pull tab until it breaks without bond loss
DOWSIL™ 995 Silicone Structural Sealant	Pull tab until it breaks without bond loss
DOWSIL™ 999A Building and Glazing Sealant	Pull tab until it breaks without bond loss
DOWSIL™ Contractors Concrete Sealant	Pull tab 3" (300% extension) without bond loss
DOWSIL™ Contractors Weatherproofing Sealant	Pull tab 1.5" (150% extension) without bond loss
DOWSIL™ FC Parking Structure Sealant	Pull tab 4" (400% extension) without bond loss
DOWSIL™ SL Parking Structure Sealant	Pull tab 4" (400% extension) without bond loss
DOWSIL™ NS Parking Structure Sealant	Pull tab 4" (400% extension) without bond loss

DOWSIL™ AllGuard Silicone Elastomeric Coating

Contractor's handbook

Substrate compatibility

DOWSIL™ AllGuard Silicone Elastomeric Coating is a one-component, pigmented, water-based silicone elastomer. It is designed to waterproof above-grade exterior masonry substrates, such as concrete block, fluted block, brick, stucco, synthetic stucco, poured concrete, precast concrete, Exterior Insulation Finish Systems (EIFS) and previously coated masonry substrates.

Compatibility with DOWSIL™ brand products

DOWSIL™ AllGuard Silicone Elastomeric Coating is compatible with the following DOWSIL™ brand products:

- DOWSIL™ 123 Silicone Seal
- DOWSIL™ 790 Silicone Building Sealant
- DOWSIL™ 791 Silicone Weatherproofing Sealant
- DOWSIL™ 795 Silicone Building Sealant

Typical properties

Please refer to the DOWSIL™ AllGuard Silicone Elastomeric Coating data sheet, Form No. 62-048, for typical property characteristics.

Temperature and humidity

DOWSIL™ AllGuard Silicone Elastomeric Coating can be applied from -6 to 38°C (20 to 100°F). Do not apply when the relative humidity is greater than 90 percent or when there is a threat of rain within 24 hours.

Priming

Field adhesion testing must be performed to determine if primer is required (*see page 12*).

1. Apply at a rate of 300 sq ft/gallon using a 1/2 - 3/4" synthetic nap roller, nylon bristle brush or airless sprayer.
2. Apply primer to the point of rundown.
3. Dry 30 minutes to 2 hours. Actual drying time will depend on temperature, humidity and wind conditions. Allow an additional 30 minutes to dry after dry to the touch.
4. Apply coating over primer at least 30 minutes after primer is dry to the touch, but within 72 hours. If the surface cannot be coated during this time, care should be taken to ensure the primed surface is free of dirt and debris before applying coating.

Estimated application rate

(10-mil minimum dry film thickness)

Texture/substrate	Estimated rate, sq ft/gal
Smooth (brick, precast concrete)	80-90
Fine (sand, #3 vermiculite)	70-80
Coarse (aggregate, split face block)	60-70

Coating

Two coats of DOWSIL™ AllGuard Silicone Elastomeric Coating are necessary to achieve the required 10-mil minimum dry film thickness to attain protection against through-water penetration and to qualify for a project-specific warranty.

Apply the coating in a 10-mil wet thickness (see table on page 12 for estimated application rates; job-specific testing is recommended for best results). Two 10-mil wet coats will result in the required 10-mil dry coating thickness. Apply using a 3/4 - 1 1/2" nap, polyester or 50/50 polyester/wool blend roller cover, nylon bristle brush or airless sprayer. Always finish roller applications in the same direction to reduce visual surface texture differences.

Allow 2 to 4 hours drying time before applying the second coat.

Please refer to the *DOWSIL™ AllGuard Silicone Elastomeric Coating Application and Maintenance Guide*, Form No. 62-617, for more detailed information. Additionally, a *Wet Film Thickness Gauge* is available, Form No. 62-619.

Adhesion test procedure

1. Prepare surfaces per instructions (see *DOWSIL™ AllGuard Silicone Elastomeric Coating Application and Maintenance Guide*, Form No. 62-617, for specific preparation information).
2. Apply the primer and allow to dry.
3. Apply the first coat of DOWSIL™ AllGuard Silicone Elastomeric Coating at a rate of 10 to 12 mils wet film thickness. Embed a cheesecloth strip (1" x 12") in the wet coating with a paint brush.
4. Apply the second coat over the cheesecloth at the same 10 to 12 mils wet film thickness and allow to fully cure for 7 to 14 days.
5. Test adhesion of the coating by pulling the uncoated part of the cheesecloth at a 180° angle at a slow, steady rate.
6. Inspect and note the percent cohesive failure (percent of coating material left on the wall surface). At least 80 percent of the

coating should remain on the substrate. If the 80 percent retention is not achieved, reclean and test another suitable section. If necessary, contact Dow Technical Service for further instruction.

Test piece

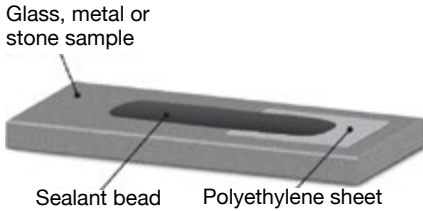

Recommended joint design

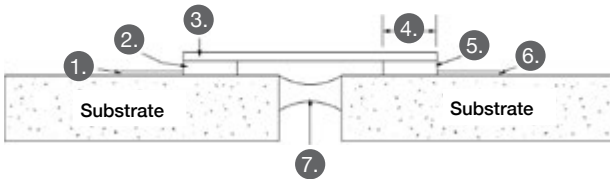

- Key:**
1. Masking tape
 2. DOWSIL™ 756 SMS Building Sealant, DOWSIL™ 791 Silicone Weatherproofing Sealant, DOWSIL™ 795 Building Sealant, or DOWSIL™ 995 Silicone Structural Sealant
 3. DOWSIL™ 123 Silicone Seal
 4. Min. bond 3/8"
 5. DOWSIL™ 756 SMS Building Sealant, DOWSIL™ 791 Silicone Weatherproofing Sealant, DOWSIL™ 795 Building Sealant, or DOWSIL™ 995 Silicone Structural Sealant
 6. Masking tape
 7. Existing sealant

Preformed custom designs

To complete the weatherproofing system and complement DOWSIL™ 123 Silicone Seal, preformed two- and three-dimensional shapes are available as DOWSIL™ 123 Silicone Seal Custom Designs H.C. The custom designs can be molded into various shapes to provide customized shapes and sizes for specific applications.

Installation

DOWSIL™ 123 Silicone Seal must be bonded to clean, dry, frost-free, dust-free substrates using DOWSIL™ 756 SMS Sealant, DOWSIL™ 791 Silicone Sealant, DOWSIL™ 795 Silicone Sealant, or DOWSIL™ 995 Silicone Sealant. Field adhesion testing should be done to determine if primer is required for proper adhesion of DOWSIL™ sealant to the substrate.

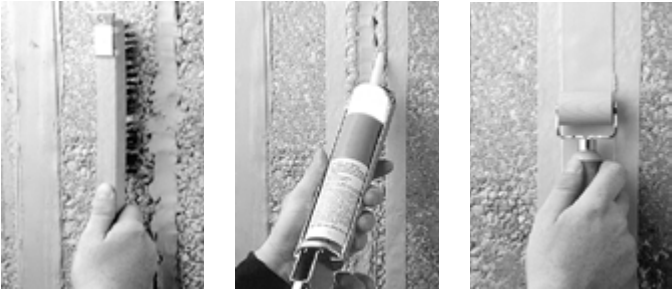

DOWSIL™ 123 Silicone Seal is easily applied: Prepare the substrate around the failed sealant; apply **DOWSIL™ 756 SMS Building Sealant**, **DOWSIL™ 791 Silicone Weatherproofing Sealant**, **DOWSIL™ 795 Building Sealant**, or **DOWSIL™ 995 Silicone Structural Sealant**; and apply **DOWSIL™ 123 Silicone Seal**.

Preparation work: Porous surfaces should be cleaned with abrasion cleaning followed by blasts of oil-free compressed air. If high-pressure water cleaning is necessary, use caution to prevent water from entering the structure through the existing failed joint. Exterior surfaces must be visibly dry before installing **DOWSIL™ 123 Silicone Seal**.

Nonporous surfaces should be cleaned using a two-cloth solvent wipe (see page 5).

Masking: Apply masking tape in areas of high visibility to ensure good aesthetics.

Application: Apply a bead of **DOWSIL™ 756 SMS Building Sealant**, **DOWSIL™ 791 Silicone Weatherproofing Sealant**, **DOWSIL™ 795 Silicone Building Sealant**, or **DOWSIL™ 995 Silicone Structural Sealant** to each side of the joint according to the following schedule:

Substrate	Coverage linear ft/tube	Bead size
Rough	20-40	1/4"
Smooth	70-120	1/8"

Note: Rough surfaces will require larger beads of sealant to seal the valleys of the substrate. The sealant should be applied approximately 1/4" inside the masking tape on both sides of the joint. Minimum bonded area must be at least 3/8".

Within 10 minutes of sealant application, press the extrusion into the sealant to wet the extrusion, substrate and sealant. A roller can be used to apply consistent pressure to ensure uniform contact.

Horizontal joints must be completed before application of vertical joints. Vertical joints should be lapped over the horizontal joints.

At the end of the joint, cut the extrusion with a razor knife.

Clean-up: Remove masking tape and excess sealant.

Adhesion test procedure

As a check for adhesion, a simple hand pull test may be run on the job site after DOWSIL™ 756 SMS Building Sealant, DOWSIL™ 791 Silicone Weatherproofing Sealant, DOWSIL™ 795 Silicone Building Sealant, or DOWSIL™ 995 Silicone Structural Sealant is fully cured (usually within 7-21 days).

1. Make a knife cut horizontally across the DOWSIL™ 123 Silicone Seal.
2. Make a vertical cut from the horizontal cut approximately 1" long down through the middle of the DOWSIL™ 756 Sealant, DOWSIL™ 791 Sealant, DOWSIL™ 795 Sealant, or DOWSIL™ 995 Sealant on both sides of the joint opening.
3. Grasp the 1" piece of DOWSIL™ 123 Silicone Seal and pull at a 90° angle. Do not destroy the silicone seal; it can be repaired later.
4. The pass-fail criterion is cohesive failure of the DOWSIL™ 756 Sealant, DOWSIL™ 791 Sealant, DOWSIL™ 795 Sealant, or DOWSIL™ 995 Sealant.

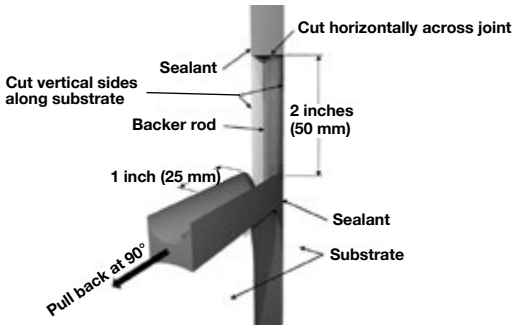

Test area repair

The silicone seal can be easily repaired by applying more sealant in the peeled off areas and rolling the seal back into the wet sealant. At the horizontal cut, apply sealant in this butt joint and smooth.

For the most up-to-date information, including product data sheets and contact information, please visit [dow.com/construction](https://www.dow.com/construction).

Literature

Some suggested literature is listed below.

Title	Form number
<i>DOWSIL™ AllGuard Silicone Elastomeric Coating Application and Maintenance Guide</i>	62-617
<i>Dow Americas Technical Manual</i>	62-1112
<i>Dow EIFS Restoration Guide</i>	62-510
<i>DOWSIL™ Parking Structure Sealants Installation Guide</i>	62-481
<i>Using the Dow Joint Movement Indicator</i>	61-637
<i>Wet Film Thickness Gauge</i>	62-619

Refer also to ASTM C1521 terminology for additional information.

A

Adhesion (% Adhesive Failure) – The degree of attachment or bonding of one substance to another. When testing sealants or coatings, adhesion is usually measured as a percentage of the total contact area. Note: A reported value of 0% Adhesive Failure means the sealant or coating has the maximum achievable bonding or adhesion. (See ASTM C1521.)

Ambient temperature – Temperature of the surrounding air on all sides. Usually considered the outdoor temperature and important when choosing sealants and coatings that may have their extrudability or cure affected at low and high temperatures.

Application temperature – Field-applied, high-performance silicone sealants can be applied from -20 to 120°F. Check product data sheet for specific ranges on each product before use, as the approved range may change.

B

Breathable, weatherproofing coating – A coating with a perm rating above about 0.5 perm. The opposite of a vapor retarder. The higher the perm rating, the more breathable the coating. Breathable, weatherproofing coatings are preferred on large porous surfaces to control humidity in a building and keep rain or water from entering.

C

Caulking (sealant) – A substance to stop and make building joints watertight against leakage. Caulking (or calking) is an older term which is now more commonly referred to as sealant by glazing and weatherproofing contractors.

Chalking – Usually a grayish or white substance, dry, chalk-like residue, forming on the surface caused by weathering. Common to see chalking on aged, outdoor-exposed painted wood. (See Contaminants.)

Coating – A liquid or semi-liquid protective finish capable of application to surfaces, usually by brush or spray, in moderate thickness. Applications include weatherproofing and protecting substrates from rain and air infiltration.

Cohesion (% cohesive failure) – A measure of the degree of attachment in which the sealant or coating tears within itself as opposed to failure at the bond line (or adhesive). Note: A reported value of 100% cohesive failure means the sealant or coating has the maximum achievable bonding strength. (See ASTM C1521.)

Combustible – Capable of uniting with air or oxygen in a reaction initiated by heating, accompanied by the subsequent evolution of heat and light.

Condensation – The process of changing from a gas or vapor to a liquid.

Contaminants – Something that makes a surface or substance unclean, pollutes, soils, stains from an outside source. Environmental deposits, salt spray, or migration of contaminants through a sealant or coating can appear to be chalking.

Coverage rate – Usually for coatings or primers to determine project quantities, commonly reported as square feet per gallon (ft²/gal) or square meters per liter (m²/l).

Cure – To change the properties of a plastic or resin by chemical reaction, which, for example, may be condensation, polymerization, or addition; usually accompanied by the action of either heat or catalyst or both, and with or without pressure.

Cure time (functional) – The time required to complete the cure process to a point when the product reaches its reported functioning properties.

D _____

Degradation – The deterioration of a substance caused by contact with its environment.

Delamination – The separation of the layers of material.

Dirt pickup – The accumulation of dirt or environmental residues on the sealant or coating surface during or after cure. Usually more predominant in industrial areas.

E _____

Elastomer – A material capable of elongating at least 100% and recovering its original dimensions.

Elastomeric – Displaying the properties of an elastomer.

Elongation (stretch) – Lengthening or stretching ability to accommodate movement.

Expansion joint – A break in a surface to allow the material to contract and expand without causing damage. It may be a working joint to allow movement or a control joint to isolate a stress.

F _____

Film thickness – The thickness of a coating or membrane, normally measured in mils. For applied coatings, it is usually expressed as either wet or dry thickness to take into account the change as the wet material dries and shrinks.

Flash point – The flash point of a liquid is the lowest temperature of the liquid at which it gives off vapor sufficient to form an ignitable mixture with the air near the surface of the liquid or within the vessel used.

G

Grout – Cement or mortar used to seal between precast concrete planks in a roof deck.

Gypsum – A fireproof board composed of calcium sulfate and fibers. Used as construction panels.

H

Hardness – The relative resistance of a material to denting, scratching or bending.

Humidity, relative – The ratio of actual pressure of existing water vapor to the maximum possible (saturation) pressure of water vapor in the atmosphere at the same temperature, expressed as a percentage. One-part, moisture-cure silicones cure faster in warmer, humid conditions and slower when the conditions are cooler and drier.

I

Impact resistance – Ability to withstand mechanical or physical abuse under severe service conditions. Resistance to blows, bumps and shocks incidental to use. Commonly associated with hurricane glazing of windows and doors for commercial and residential ratings.

L

Laitance – Surface material on top of concrete made up of fine cement and aggregate particles. It is loosely bonded and of low strength and must be removed by wire brushing before coating can be applied.

Lightweight concrete – A nonstructural concrete using materials such as vermiculite or perlite as aggregate.

M

Mil – A unit in measuring thickness, being 0.001 inch (British equivalent: Thou.) (Metric equivalent: 0.0254 mm).

Modulus (low, medium, high) – A relative description usually related to a sealant's movement to stress ratio. Low-modulus silicone products are more easily stretched (for expansion joint use); high-modulus silicone sealants are harder to stretch or stronger (for structural glazing use).

Monolithic – Single form or single piece; individual glass panel or formed or composite panels.

O

Organic (non-silicone) – Compounds consisting of carbon and generally hydrogen, with a restricted number of other elements. Common sealant examples include urethanes, polyurethanes, polysulfides and acrylics. Organics are susceptible to degradation caused by the effects of sunlight, heat and other outdoor exposure conditions.

P

Parapet – A wall rising above the level of the roof, usually around its perimeter.

Penetration – Any assembly that goes through a roof deck, such as a vent, exhaust fan, electrical feed-through, roof drain, stand pipe, etc.

Perm rating – A measure of a material's ability to pass water vapor.

Pinhole – A very small hole or imperfection in a coating through which water or ultraviolet light can enter and cause damage.

Polymer – A chemical compound or mixture of compounds formed essentially of repeating structural units. The properties of the polymer, which is the backbone (major constituent) of sealants, result in the primary differences between silicone and organic products.

Primer – A chemical material that improves the bond of the sealant or coating to the substrate.

R

R Factor – Resistance of heat flow through a particular thickness of material.

Reversion – Urethane sealants lose their original rheological properties over time (i.e., their ability to actually seal joints).

S

Scupper – A hole in the wall to allow water to course through.

Shore "A" hardness – A relative measurement scale of firmness of a compound by means of a durometer hardness gauge. A soft or low-modulus sealant may have a durometer of approximately 15 Shore A; a firm silicone gasket would be closer to 70 Shore A. For very soft materials, a Shore scale of "00" is used to measure the hardness.

SDS (Safety Data Sheet) – Contains written instructions for the safe use of sealants, coatings, primers, solvents and many other products. Always read and understand the SDS before using any sealant, coating, primer or cleaning solvent.

Shrinkage crack – Fine hairline cracks in the surface of newly cured concrete. Overall pattern looks like a crushed egg shell.

Solids content – The percentage of nonvolatile matter that may be measured in volume or weight.

Solvent – Any substance, usually a liquid, that dissolves other substances. In coatings, normally a liquid organic compound used to make a fluid coating apply more freely.

Structural concrete – Reinforced concrete with a compressive strength of at least 2500 psi.

Structural crack – Concrete crack subject to little movement but that must be repaired since it can go through a full-slab thickness and leak.

T

Tack-free – A film is considered tack-free when a finger tip, with a slight pressure, does not transfer material. (See ASTM C679 Tack Free Time.)

Tensile strength (ultimate) – The force per unit area that is applied at the time of rupture of the specimen. It is calculated by dividing the breaking force in pounds by the cross-section of the unstretched specimen in square inches.

U

U Factor – The overall heat transfer factor for a particular building component, such as a roof.

UL rating – A flammability rating system for materials as tested by Underwriters Laboratories. UL classifies or lists materials that pass their specific tests.

UV – Ultraviolet radiation or sunlight.

Urethane sealant reversion – Specific to some urethanes where they revert to a sticky substance when subjected to conditions of UV, heat and humidity. The cured sealants lose their functional properties over time (i.e., their ability to seal and function as a joint sealant).

V

Vapor retarder – Those materials or systems that retard the transmission of vapor under specified conditions.

Vent – An opening or device put in a roof system to allow moisture vapor to escape.

Viscosity – The property of resistance to flow exhibited within the body of a material. Thicker material will give a higher viscosity value when tested.

W

Water absorption – The increase in weight of a test specimen expressed as a percentage of its dry weight after immersion in water for a specified time.

Your local distributor is:

Images: dow_40253003595, dow_40977340569, dow_40647262496, dow_40145810664, dow_40145811624, dow_40145812440

PRODUCT SAFETY INFORMATION REQUIRED FOR SAFE USE IS NOT INCLUDED IN THIS DOCUMENT. BEFORE HANDLING, READ PRODUCT AND SAFETY DATA SHEETS AND CONTAINER LABELS FOR SAFE USE, PHYSICAL AND HEALTH HAZARD INFORMATION. THE SAFETY DATA SHEET IS AVAILABLE ON THE DOW WEBSITE AT WWW.DOW.COM, OR FROM YOUR DOW SALES APPLICATION ENGINEER, OR DISTRIBUTOR, OR BY CALLING DOW CUSTOMER SERVICE.

NOTICE: No freedom from infringement of any patent owned by Dow or others is to be inferred. Because use conditions and applicable laws may differ from one location to another and may change with time, Customer is responsible for determining whether products and the information in this document are appropriate for Customer's use and for ensuring that Customer's workplace and disposal practices are in compliance with applicable laws and other government enactments. The product shown in this literature may not be available for sale and/or available in all geographies where Dow is represented. The claims made may not have been approved for use in all countries. Dow assumes no obligation or liability for the information in this document. References to "Dow" or the "Company" mean the Dow legal entity selling the products to Customer unless otherwise expressly noted. NO WARRANTIES ARE GIVEN; ALL IMPLIED WARRANTIES OF MERCHANTABILITY OR FITNESS FOR A PARTICULAR PURPOSE ARE EXPRESSLY EXCLUDED.

®™ Trademark of The Dow Chemical Company ("Dow") or an affiliated company of Dow

© 2020 The Dow Chemical Company. All rights reserved.

2000000327

Form No. 62-621-01-0120 S2D