



DOWSIL™ 890-SL Silicone Joint Sealant

Self-leveling silicone sealant for concrete and concrete to asphalt pavement joints.

Features & Benefits

- Self-leveling, no tooling required.
- Can be extruded from -20 to 120°F.
- Flows into irregular joint widths and does not require tooling.
- Movement capability 100% extension and 50% compression.
- Ultra-low modulus.
- Weather and UV resistant.
- Fuel resistant-short term exposure. Refer to Dow form number 62-207 for more information.
- Cold applied, ready-to-use as supplied. No heating or special preparation.
- Unprimed adhesion-primer is not required for Portland cement concrete and asphalt which results in labor and material savings.
- Skin over- typically, the sealant will have a skin-over time of one hour or less at standard conditions allowing roadways to quickly be opened to traffic.

Composition

- One-part, cold applied, self-leveling silicone

Applications

- DOWSIL™ 890-SL Silicone Joint Sealant can be used for concrete to concrete and concrete to asphalt pavement joints.
- For use in new construction, repair or remedial applications. DOWSIL™ 890-SL Silicone Joint Sealant can be used to seal irregularly shaped and spalled joints.

Typical Properties

Specification Writers: These values are not intended for use in preparing specifications.

Test ¹	Property	Result	D 5893 Requirement
	As supplied		
	Color	Dark gray	
ASTM C 639	Flow	Pass	Smooth, level
ASTM C 1183	Extrusion rate, minimum	231 mL/min	20 mL/min
ASTM C 679	Tack free time	Pass	5 hours max

1. ASTM: American Society for Testing and Materials

Typical Properties (Cont.)

Test	Property	Result	D 5893 Requirement
ASTM C 792	Heat aging	0.97%	10% loss max
ASTM C 661	Durometer Shore 00	41	30 minimum
ASTM D 1475	Specific gravity	1.26–1.34	
	Cure time, ½" x ½" x 2" (73°F, 50% R.H.)	Pass	21 day cure
As Cured – 21 days at 25°C (77°F) and 50% RH			
	Bond, non-immersed	Pass	No cracks or separation
	Bond, water immersed	Pass	No cracks or separation
	Bond, oven aged	Pass	No cracks or separation
ASTM D 412	Ultimate elongation	1400%	600% min
ASTM D 412	Tensile stress @ 150%	9 psi	45 psi max
ASTM C 793	Effects of accelerate weathering	Pass	5,000 hours
	Resilience	77%	75% min
ASTM C 719	Joint movement capability, +100/-50 percent, 10 cycles	No failure	

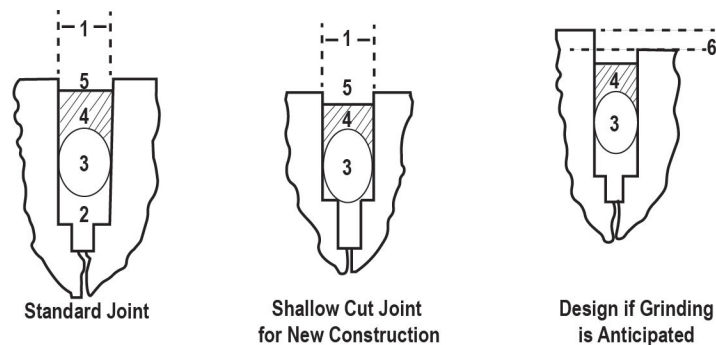

Figure 1: Good Joint Design

¹Joint width wide enough to accommodate movement. (For additional information on joint width, see papers by Spells and Klosowski, "Silicone Sealants for Use in Concrete Construction," Vol. 1, No. 1, American Concrete Institute, SP-70, 1981; J.B. Cook, "Construction Sealants and Adhesives," Wiley-Interscience, 1970; and J.M. Klosowski, "Sealants in Construction," Marcel Dekker, 1989.)

²Joint sawed deep enough to allow backer rod/sealant placement and space for pumping of old sealant compounds. NOTE: This applies to standard joints only; void space beneath backer rod in new construction is not needed.

³Proper backer rod placement to prevent three-sided adhesion.

⁴Sealant installed to proper depth and width.

⁵Sealant recessed a minimum of 3/8 inch to 1/2 inch (9.53 mm to 12.7 mm) below pavement surface.

⁶Depth of lowest slab determines the amount of recess required if grinding is anticipated; once grinding is complete, the sealant will have proper recess below the pavement surface.

Description

DOWSIL™ 890-SL Silicone Joint Sealant is a one-part, self-leveling silicone material that cures to an ultra-low-modulus silicone rubber upon exposure to atmospheric moisture. The cured silicone rubber remains flexible from -20 to 300°F.

Asphaltic paving materials have low tensile strengths. It is important to use an ultra-low modulus material when sealing these substrates to ensure minimal strain is placed on the asphaltic joint face.

Applicable Standards

- ASTM D 5893 Type SL
- FAA P-605 for silicone joint sealants
- Meets SS-S-200E (section 4.4.12) Flame Test Requirements
- EN 14187-5 Hydrolysis Test
- EN 14188-2 Class B, C and D

How To Use

Please refer to the Dow Silicone Pavement Sealants Installation Guide, form number 61-507.

Handling Precautions

PRODUCT SAFETY INFORMATION REQUIRED FOR SAFE USE IS NOT INCLUDED IN THIS DOCUMENT. BEFORE HANDLING, READ PRODUCT AND SAFETY DATA SHEETS AND CONTAINER LABELS FOR SAFE USE, PHYSICAL AND HEALTH HAZARD INFORMATION. THE SAFETY DATA SHEET IS AVAILABLE ON THE DOW WEBSITE AT DOW.COM, OR FROM YOUR DOW SALES APPLICATION ENGINEER, OR DISTRIBUTOR, OR BY CALLING DOW CUSTOMER SERVICE.

Usable Life And Storage

Keep stored in original, unopened containers at or below 32°C (90°F). Refer to product packaging for "Use By" date. Keep containers tightly closed.

Packaging Information

DOWSIL™ 890-SL Silicone Joint Sealant is supplied in 29 fl oz (857 mL) disposable plastic cartridges, 4.5 gal (17 L) bulk pails, and 50 gal (189 L) bulk drums.

Limitations

DOWSIL™ 890-SL Silicone Joint Sealant is not recommended for continuous water immersion. It should not be applied in totally confined spaces where the sealant is not exposed to atmospheric moisture.

The sealant should never be applied to wet or damp asphalt or concrete pavements or installed during inclement weather.

Contact Dow prior to specifying for or installing in airfield runway applications.

Dow does not promote or warrant the use of DOWSIL™ sealants in applications associated with spill containment areas of any kind.

This product is neither tested nor represented as suitable for medical or pharmaceutical uses.

Shipping Limitations

None.

Health And Environmental Information

To support customers in their product safety needs, Dow has an extensive Product Stewardship organization and a team of product safety and regulatory compliance specialists available in each area.

For further information, please see our website, dow.com or consult your local Dow representative.

Disposal Considerations

Dispose in accordance with all local, state (provincial) and federal regulations. Empty containers may contain hazardous residues. This material and its container must be disposed in a safe and legal manner.

It is the user's responsibility to verify that treatment and disposal procedures comply with local, state (provincial) and federal regulations. Contact your Dow Technical Representative for more information.

Product Stewardship

Dow has a fundamental concern for all who make, distribute, and use its products, and for the environment in which we live. This concern is the basis for our product stewardship philosophy by which we assess the safety, health, and environmental information on our products and then take appropriate steps to protect employee and public health and our environment. The success of our product stewardship program rests with each and every individual involved with Dow products - from the initial concept and research, to manufacture, use, sale, disposal, and recycle of each product.

Customer Notice

Dow strongly encourages its customers to review both their manufacturing processes and their applications of Dow products from the standpoint of human health and environmental quality to ensure that Dow products are not used in ways for which they are not intended or tested. Dow personnel are available to answer your questions and to provide reasonable technical support. Dow product literature, including safety data sheets, should be consulted prior to use of Dow products. Current safety data sheets are available from Dow.

Table 1: Recommended Backer Rod Installation (Shallow Cut)¹

Measured in Inches						
Joint Width	1/4	3/8	1/2	3/4	1	> 1
Recessed Below Surface	3/8	3/8	3/8–1/2	3/8–1/2	1/2+	Contact Dow
Sealant Thickness	1/4	1/4	1/4	3/8	1/2	
Backer Rod Diameter	3/8	1/2	5/8	7/8	1 1/4	
Total Joint Depth	1–1 1/8	1 1/8–1 1/4	1 1/4–1 3/8	1 5/8–1 3/4	2 1/4–2 3/8	
Measured in Millimeters						
Joint Width	6	9	13	19	25	
Recessed Below Surface	9	9	9–13	9–13	13+	
Sealant Thickness	6	6	6	9	13	
Backer Rod Diameter	9	13	16	22	32	
Total Joint Depth	25–29	29–32	32–35	41–45	57–60	

1. On road surfaces where grinding is planned at a later date, the sealant and backer rod should be installed so that sealant is approximately 3/8 inch (9.35 mm) below the road surface after grinding is complete. An additional small amount should be added to allow for surface imperfections on the bottom and to provide room for old sealant to pump up from below during rehabilitation work in the summer months.

dow.com

NOTICE: No freedom from infringement of any patent owned by Dow or others is to be inferred. Because use conditions and applicable laws may differ from one location to another and may change with time, Customer is responsible for determining whether products and the information in this document are appropriate for Customer's use and for ensuring that Customer's workplace and disposal practices are in compliance with applicable laws and other government enactments. The product shown in this literature may not be available for sale and/or available in all geographies where Dow is represented. The claims made may not have been approved for use in all countries. Dow assumes no obligation or liability for the information in this document. References to "Dow" or the "Company" mean the Dow legal entity selling the products to Customer unless otherwise expressly noted. NO WARRANTIES ARE GIVEN; ALL IMPLIED WARRANTIES OF MERCHANTABILITY OR FITNESS FOR A PARTICULAR PURPOSE ARE EXPRESSLY EXCLUDED.

