

INFINITY[®] SYSTEM



A Patented Pressure-Equalized Rainscreen Exterior Insulation and Finish System That Incorporates Continuous Insulation and An Air/Water-Resistive Barrier

DS145

Infinity System Application Instructions

Table of Contents	
Section I	General Installation Requirements
Section II	Materials Required for Completing Installation of the Infinity System
Section III	Mixing Instructions
Section IV	Rough Opening Preparation Options
Section V	Substrate Expansion Joint Bridging Options
Section VI	Air/Water-Resistive Barrier Application
Section VII	Accessories
Section VIII	Installation of I.S. Closure Blocks
Section IX	Installation of I.S. Insulation Board
Section X	Installation of Reinforcing Mesh and I. S. Base Coat
Section XI	Sealant Joint Preparation
Section XII	Dryvit Primers
Section XIII	Dryvit Finish
Section XIV	Coatings and Sealers
Section XV	Maintenance and Repair

I. General Installation Requirements**A. Project Conditions**

1. Storage

- a. Materials shall be stored at the job site, and at all times, in a cool, dry location, out of direct sunlight, protected from weather and other sources of damage. Minimum storage temperature shall be as follows:
 - 1) DPR, PMR™, HDP™, Weatherlastic®, and E Finishes™, Color Prime™, Primus®, Genesis® and NCB™: 40 °F (4 °C).
 - 2) For all other products, refer to specific product data sheets.
- b. Maximum storage temperature shall not exceed 100 °F (38° C). **NOTE: Minimize exposure of materials to temperatures over 90 °F (32 °C). Finishes exposed to temperatures over 110 °F (43 °C) for even short periods may exhibit skinning, increased viscosity and should be inspected prior to use.**
- c. Protect all products from inclement weather and direct sunlight.

2. Application

- a. Application of wet materials shall not take place during inclement weather unless appropriate protection is provided. Protect materials from inclement weather until they are completely dry.
 - 1) At the time of Dryvit product application, the air and wall surface temperatures shall be from 40 °F (4 °C) minimum to 100 °F (38° C) maximum for the following products:
 - a) DPR, PMR, HDP, Weatherlastic and E Finishes, Color Prime, Primus, Genesis and NCB: 40 °F (4 °C).
 - b) For all other products, refer to specific product data sheets.

3. These temperatures shall be maintained with adequate air ventilation and circulation for a minimum of 24 hours (48 hours for Weatherlastic Finishes, Ameristone™, TerraNeo® and Limestone™) thereafter, or until the products are completely dry. Refer to published product data sheets for more specific information.

B. Inspection of Substrate

1. Acceptable substrate for application of the Dryvit Infinity System is listed in the Dryvit Infinity System Specification, [DS136](#).
2. The substrate must be securely fastened per contract documents.
3. The substrate attachment method must comply with all contract documents.
4. The substrate must be clean, dry, structurally sound, free of loose material, voids, projections, hot spots, release agents, coatings, or other materials that may affect adhesion.
5. There shall be no planar irregularities greater than 1/4 in (6.4 mm) within any 4 ft (1.2 m) radius.

C. Flashing at System Terminations

1. General

- a. Ensure that flashing is installed in accordance with applicable code requirements and the contract documents. As a minimum, opening preparation is required as shown in the Infinity System Installation Details, [DS120](#).

2. Transition at Roof Lines

- a. Ensure the roof has positive drainage, i.e., all runoff shall be directed to the exterior and away from the structure.
- b. Roof flashing (by others) shall be installed in accordance with industry guidelines, manufacturer's instructions and contract documents.
- c. Runoff diverters (i.e., kickouts, crickets and saddles) (by others) shall be installed in accordance with industry guidelines, manufacturer's instructions and contract documents. Particular attention must be paid to the eaves/chimney intersections and sloped roof/wall intersections. Refer to the Dryvit Infinity System Installation Details, [DS120](#).
- d. Hold system a minimum of 8 in (203 mm) above flat roofs; 2 in (51 mm) above sloped roofs.

3. Openings

- a. Heads, jambs and sills of all openings shall be prepared with Dryvit Backstop® NT, AquaFlash®, Flashing Tape™ or other approved flashing material selected by the design professional prior to window/door, mechanical equipment, or other component installation. For proper application, refer to the Dryvit Infinity System Installation Details, [DS120](#).

NOTE: Sill piece shall extend to the inside face of wall and continue a minimum of 4 in (102 mm) up at the jambs.

- b. Continuous flashing at heads of openings as indicated in contract documents. **NOTE: For windows or doors that do not have integral flashing, a field-applied flashing shall be installed (by others) in accordance with industry guidelines, manufacturer's instructions and contract documents. Refer to the Dryvit Infinity System Installation Details, [DS120](#).**

- c. Individual windows that are ganged to make multiple units require that the heads to be continuously flashed and the joints between the units must be fully sealed.

4. Decks and Patios

- a. Wood decks shall be properly flashed prior to system application. See the Dryvit Infinity System Installation Details, [DS120](#).

- b. Verify that the system terminates above poured decks, patios, landings, etc. and that they are properly sloped and waterproofed to direct water away from the walls.

5. Utilities

- a. Provisions must be made to ensure that the system terminates properly at lighting fixtures, electrical outlets, hose bibs, dryer vents, etc. Refer to the Dryvit Infinity System Installation Details, [DS120](#).

6. Grade Level Terminations

- a. Hold system a minimum of 8 in (203 mm) above finished grade.

D. Sealants

1. Dryvit materials shall be completely dry prior to installation of sealant materials (typically 48 - 72 hours). Humid or cool conditions may require longer drying times.

Notify the general contractor and/or architect and/or owner of all discrepancies. Do not proceed until all unsatisfactory conditions have been corrected.

II. Materials Required for Completing Installation of the Infinity System

A. Materials Supplied by Dryvit Systems, Inc.

1. AquaFlash and AquaFlash Mesh
2. Backstop NT – Texture and/or Backstop NT – Smooth
3. Grid Tape™
4. Dryvit Flashing Tape and Flashing Tape Surface Conditioner™
5. AP Adhesive™
6. Dryvit Starter Strips™
7. Drainage Vent Assemblies
8. Dryvit Track
9. Dryvit Vent Track
10. Genesis®, Genesis® DM, Genesis® DMS
11. Primus®, Primus® DM
12. I.S. Base
13. I.S. Mesh, Panzer® 15, Panzer 20, Corner™, and Detail Mesh®
14. Infitex® Finishes
15. Dryvit Finishes
16. Dryvit Coatings and Primers

NOTE: Materials listed above are those contained or referenced in the Infinity Specification, DS136.

Typically the project specification will identify the specific materials necessary to complete application.

B. Materials Supplied by Others

1. Portland Cement: Type I or II
2. Clean Potable Water
3. I.S. Insulation Board, I.S. Closure Blocks and Dryvit Starter Strips.
4. Georgia Pacific Dens-Glass Gold
5. Dow Corning Sealant and Primer
6. Tremco Sealant and Primer

III. Mixing Instructions

A. General

1. No additives such as sand, aggregates, rapid binders, anti-freeze, accelerators, etc. shall be added to any Dryvit materials under any circumstances. **Such additives will adversely affect the performance of the material and void all warranties.**

B. Opening Preparation Materials

1. AquaFlash
 - a. Open the bucket with a utility knife or lid-off.
 - b. AquaFlash is ready to use after an initial spin-up using a “Twister” paddle or equivalent mixing blade, powered by a 1/2 in (12.7 mm) drill, at 450 - 500 rpm. Do not add cement or any other additives.
2. Backstop NT
 - a. Open the bucket with a utility knife or lid-off.
 - b. Backstop NT is ready to use after an initial spin-up using a “Twister” paddle or equivalent mixing blade, powered by a 1/2 in (12.7 mm) drill, at 450 - 500 rpm. Do not add cement or any other additives.

C. Adhesive

1. Primus or Genesis
 - a. Open the bucket with a utility knife or lid-off.
 - b. Due to shipping and storage, there may be some separation of materials. Prior to splitting the material and adding Portland cement, mix the material thoroughly. Use a “Twister” paddle or equivalent mixing blade powered by a 1/2 in (12.7 mm) drill, at 500 - 1200 rpm only. **NOTE: A minimum 7 amp drill works best for Portland cement based materials. CAUTION: Do not over-mix or use other types of mixing blades**

as air entrapment and product damage may occur and result in workability and performance problems.

- c. Pour 1/2 of the freshly mixed material [approximately 30 lbs (13.5 kg)] into a clean plastic container.
 - d. Add 1/3 of a bag [approximately 30 lbs (13.5 kg)] of fresh, lump free Type I or II Portland cement. Either gray or white cement is acceptable. Add cement slowly and mix thoroughly. **Do not add large quantities of cement at one time.**
 - e. Clean potable water may be added to the mixture to adjust the workability.
 - 1) Primus
 - a) Add as little water as possible, in small increments, and only after the Portland cement is thoroughly mixed. **Do not over water as this will degrade the performance and promote efflorescence.**
 - b) Mix the Primus material with Portland cement thoroughly; then wait five (5) minutes and mix again to break the initial set. Retempering with a small amount of water is permissible provided the mixture has not set. The mixture has a pot life similar to other Portland cement plaster material. Mix only as much material as can be conveniently used during a work period.
 - 2) Genesis
 - a) Add 1 qt (950 ml) of water prior to adding Portland cement. Additional water may be added to adjust workability.
 - b) Mix the Genesis material with Portland cement thoroughly; then wait ten to fifteen (10-15) minutes and mix again to break the initial set. Retempering with a small amount of water is permissible provided the mixture has not set. The mixture has a pot life similar to other Portland cement plaster material. Mix only as much material as can be conveniently used during a work period.
2. Primus DM
 - a. Pail Mixing
 - 1) One 50 lb (22.7 kg) bag of material will produce approximately 5 gal (19 L) of Primus DM mixture. Add 1.5 gal (5.7 L) of clean potable water into a clean plastic container.
 - 2) Add Primus DM slowly while mixing using a "Twister" paddle or equivalent mixing blade, powered by a 1/2 in (12.7 mm) drill, at 500 - 1200 rpm. **NOTE: A minimum 7 amp drill works best for Portland cement based materials.**
 - 3) Thoroughly mix until uniformly wetted, adjusting consistency with a small amount of water or Primus DM material.
 - 4) Allow the mixture to set a minimum of five (5) minutes then retemper, adding a small amount of water if necessary. Material must be free of lumps before using.
 - b. Mortar Mixer
 - 1) Add 1.5 gal (5.7 L) of clean potable water for each 50 lb (22.7 kg) bag of Primus DM into a clean mortar mixer.
 - 2) Add the Primus DM while the mixer is running. Mix three to five (3 to 5) minutes, shut mixer off for five (5) minutes, then run mixer for another two to three (2 to 3) minutes to break the set and add a small amount of water if necessary to adjust the workability. The pot life is one to three (1 to 3) hours depending on weather.
 3. Genesis DM
 - a. Pail Mixing
 - 1) One bag of Genesis DM will produce approximately 5 gal (19 L) of Genesis DM mixture. To a clean 5 gal (19 L) pail, add 6 - 7 qt (5.7 - 6.6 L) of clean potable water.
 - 2) Add the Genesis DM slowly while constantly mixing with a "Twister" paddle or equivalent mixing blade, powered by a 1/2 in (12.7 mm) drill, at 500 - 1200 rpm. **NOTE: A minimum 7 amp drill works best for Portland cement based materials.**
 - 3) Thoroughly mix until uniformly wetted, adjusting consistency with a small amount of water or Genesis DM.
 - 4) Let set for ten (10) minutes. Retemper, adding a small amount of water if necessary. Material must be free of lumps before using.
 - b. Mortar Mixer
 - 1) Add 6 - 7 qt (5.7 - 6.6 L) of clean potable water for each 50 lb (22.7 kg) bag of Genesis DM into a clean mortar mixer.
 - 2) Add the Genesis DM while the mixer is running. Mix 3 to 5 minutes, shut the mixer off for 10 minutes, then run mixer for another two to three (2 to 3) minutes to break the set adding a small amount of water if necessary to adjust workability. The pot life is 1 to 1 1/2 hours depending on weather.
 4. Genesis DMS
 - a. Sprayer
 - 1) Connect a source of clean, cool potable water to a spray machine suitable for EIFS applications.
 - 2) Regulate the water flow rate to provide the desirable mixing consistency of material. Material may thicken up upon leaving the mixing cylinder at a given water flow and loosen up after pumping. **NOTE: The consistency for application must be determined after pumping.**

- b. Pail Mixing
 - 1) One bag of Genesis DMS will produce approximately 5 gal (19 L) of Genesis DMS mixture. To a clean 5 gal (19 L) pail, add 7 - 9 qt (6.6 - 8.5 L) of clean, cool potable water.
 - 2) Add the Genesis DMS slowly while continuously mixing with a "Twister" paddle or equivalent mixing blade, powered by a 1/2 in (12.7 mm) drill, at 500 - 1200 rpm. **NOTE: A minimum 7 amp drill works best for Portland cement based materials.**
 - 3) Thoroughly mix until uniformly wetted, adjusting consistency with a small amount of water or Genesis DMS.
 - 4) Let set for five (5) minutes. Retemper, adding a small amount of water if necessary. Material must be free of lumps before using.
- c. Mortar Mixer
 - 1) Add 7 - 9 qt (6.6 - 8.5 L) of clean, cool potable water for each 50 lb (22.7 kg) bag of Genesis DMS into a clean mortar mixer.
 - 2) Add the Genesis DMS while the mixer is running. Mix three to five (3 to 5) minutes, shut the mixer off for five (5) minutes, then run mixer for another two to three (2 to 3) minutes. Retemper, adding a small amount of water if necessary. Material must be free of lumps before using. The pot life is one to three (1 to 3) hours depending on weather.
- D. Base Coat only
 - 1. I.S. Base Coat™
 - a. Open the bucket with a utility knife or lid-off.
 - b. Due to shipping and storage, there may be some separation of materials. Prior to splitting the material and adding Portland cement, mix the material thoroughly. Use a "Twister" paddle or equivalent mixing blade, powered by a 1/2 in (12.7 mm) drill, at 500 - 1200 rpm. **NOTE: A minimum 7 amp drill works best for Portland cement based materials. CAUTION: Do not over-mix or use other types of mixing blades as air entrapment and product damage may occur and result in workability and performance problems.**
 - c. The I.S. Base is mixed in a 2:1 ratio, by weight, with Portland cement. Pour 1/2 of the freshly mixed material [approximately 30 lbs (13.5 kg)] into a clean plastic container.
 - d. Add 15 lbs (6.8 kg) of fresh, lump free Type I or II Portland cement. Either gray or white cement is acceptable. Add cement slowly and mix thoroughly. **Do not add large quantities of cement at one time.**
 - e. Clean potable water may be added to the mixture to adjust the workability. Add as little water as possible, in small increments, and only after the Portland cement is thoroughly mixed. **Do not over-water as this will degrade the performance and promote efflorescence.**
 - f. Mix the I.S. Base with Portland cement thoroughly; then wait five (5) minutes and mix again to break the initial set. Retempering with a small amount of water is permissible provided the mixture has not set. The mixture has a pot life similar to other Portland cement plaster material. Mix only as much material as can be conveniently used during a work period.
- E. Primers
 - 1. Color Prime™, Color Prime - W™, Primer with Sand™
 - a. Mix material with a "Twister" paddle or equivalent mixing blade, powered by a 1/2 in (12.7 mm) drill, at 450 - 500 rpm to a homogeneous consistency.
- F. Finish
 - 1. Infinitex QP®, Infinitex SP®, Infinitex SPR, Infinitex ADB®
 - a. Thoroughly mix the factory-prepared Infinitex finish with a "Twister" paddle or equivalent mixing blade powered by a 1/2 in (12.7 mm) drill, at 450 - 500 rpm, until a uniform, homogeneous consistency is attained. A small amount of clean potable water may be added to adjust workability. Always add the same amount of water to each pail within a given lot to avoid color variation.
- G. Specialty Finishes
 - 1. Ameristone
 - a. Mix Ameristone for approximately 1 minute to ensure uniformity using a "Twister" paddle or equivalent mixing blade powered by a 1/2 in (12.7 mm) drill, at 450 - 500 rpm, just prior to application. **DO NOT OVERMIX.**
 - b. Mix all pails for the same amount of time.
 - c. If clean potable water is added as described in [DS142](#) for various application techniques, the same amount must be added to each pail.
 - 2. Stone Mist®
 - a. Mix Stone Mist for 1 minute to ensure uniformity using a "Twister" paddle or equivalent mixing blade, powered by a 1/2 in (12.7 mm) drill, 450 - 500 rpm, just prior to application. **DO NOT OVERMIX.**
 - 3. TerraNeo
 - a. Mix TerraNeo for 1 minute just prior to application, to ensure uniformity using a "Twister" paddle or equivalent mixing blade, powered by a 1/2 in (12.7 mm) drill, at 450 - 500 rpm. **DO NOT OVERMIX.**
 - 4. Limestone
 - a. Mix Limestone with a "Twister" paddle or equivalent mixing blade, powered by a 1/2 in (12.7 mm) drill, at 450 - 500 rpm until a uniform workable consistency is attained.
NOTE: If using a tint pack to color finish please refer to Tint Pack Mixing Instructions, [DS750](#).

5. Custom Brick Finishes
 - a. For Custom Brick finishes, refer to Dryvit Custom Brick Application Instructions, [DS154](#), for complete mixing instructions.

NOTE: If using a tint pack to color finish please refer to Tint Pack Mixing Instructions, [DS750](#).
 6. Reflectit
 - a. Gently mix, stir, or box Reflectit to a smooth, homogeneous consistency. Refer to Reflectit Application Instructions, [DS124](#) for complete mixing instructions.
- H. Coatings and Sealers
1. Demandit Smooth, Demandit Sanded, HDP Water-Repellent Coating and Weatherlastic® Smooth
 - a. Mix material with a “Twister” paddle or equivalent mixing blade, powered by a 1/2 in (12.7 mm) drill, at 450 - 500 rpm to a homogeneous consistency.
 2. Tuscan Glaze™
 - a. Mix Tuscan Glaze with a “Twister” paddle or equivalent mixing blade, powered by a 1/2 in (12.7 mm) drill, at 450 - 500 rpm to a homogeneous consistency, immediately prior to application. As an alternate, boxing of buckets is acceptable. **Continuously** agitate throughout application to ensure color consistency.
 3. SealClear™
 - a. Stir material thoroughly before using and stir often during the application process. As an alternate, boxing of buckets is acceptable.

IV. Rough Opening Preparation Options

- A. AquaFlash System Option
1. AquaFlash must be installed to provide a continuous barrier from the air/water-resistive barrier/sheathing substrate onto the framing edges at discontinuities and terminations such as openings, expansion joints, tops of parapets, etc. Refer to Dryvit Infinity System Installation Details, [DS120](#).
 2. Surface Preparation
 - a. Apply only when air and surface temperatures are above 40 °F (4 °C).
 - b. The surface to receive the AquaFlash System must be clean, dry, smooth and free of any condition that will hinder adhesion.
 - c. Clean loose dust or dirt from the surface by wiping with a clean, dry cloth or brush.
 3. AquaFlash System Application
 - a. Rough Openings (Windows, Doors, Others)
 - 1) Cut AquaFlash Mesh to proper length [rough opening plus 4 in (102 mm)] extending 2 in (51 mm) past each jamb – Figure 1.

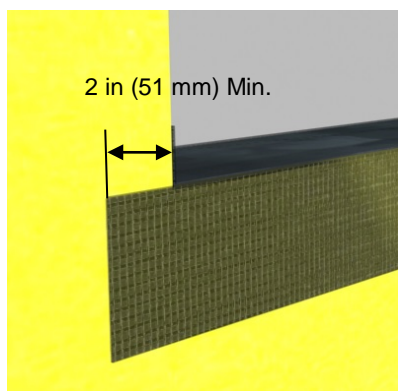

Figure 1

- 2) Begin at the sill of an opening. Using a brush or 3/4 in (19 mm) nap roller, apply a liberal coat of AquaFlash Liquid material to the water-resistive barrier/substrate surface. **NOTE: The AquaFlash System must extend to the interior face of the wall opening.**
- 3) Immediately lay the AquaFlash Mesh into the wet material and brush smooth adding additional material to completely embed the mesh - Figure 2.

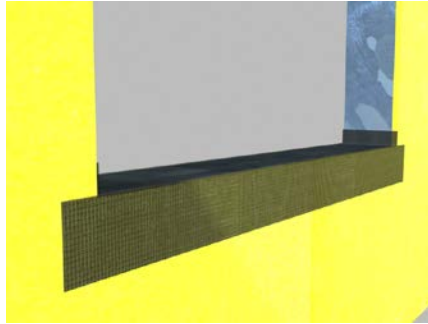

Figure 2

- 4) Install the AquaFlash System at the jambs in the same manner overlapping onto the sill material a minimum of 2 in (51 mm) – Figure 3.

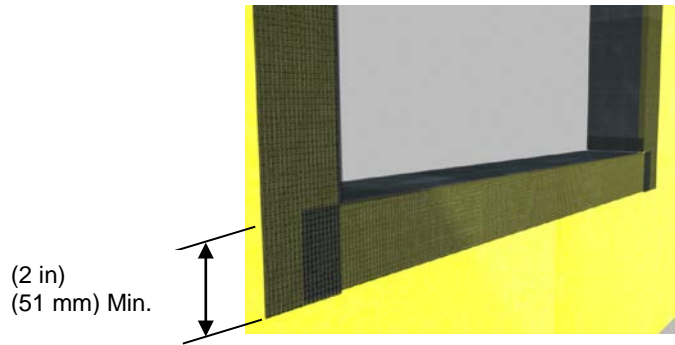

Figure 3

- 5) Install the AquaFlash System at the head overlapping the jamb pieces a minimum of 2 in (51 mm) – Figure 4.

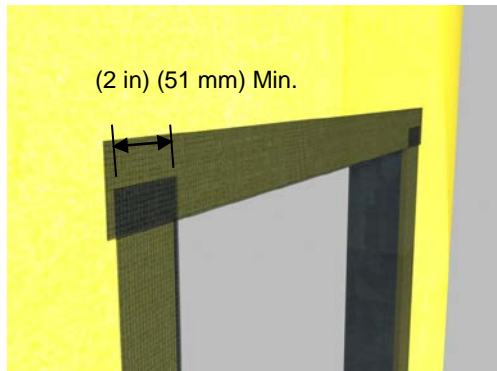

Figure 4

- 5a. As an alternative, preformed Dryvit AquaFlash Corners can be applied at each corner of the opening to reduce the number of field cuts required. The AquaFlash Corners are installed in the same manner as the AquaFlash Mesh. – Figure 5

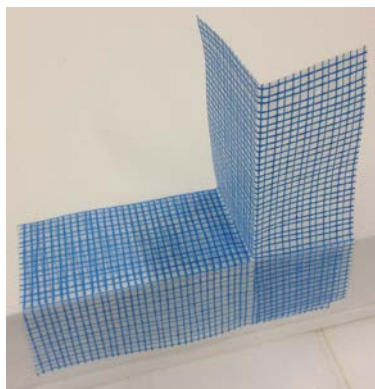

Figure 5

- 6) Install diagonal “butterflies” consisting of AquaFlash Liquid and AquaFlash Mesh at each sill/jamb corner – Figure 6.



Figure 6

- 7) Allow material to set for approximately fifteen (15) minutes then apply a second liberal coat of AquaFlash Liquid and smooth out to ensure a continuous film free of voids, pinholes, or other discontinuities.

4. Sill Pan Flashing (Exposed)

- a. Install a watertight pan flashing at all sill locations - Figure 7.
- b. The flashing shall extend between the framing members of the rough opening and shall be sized to protect the sill, sheathing and the surface of the Infinity System. It must include vertical legs at the back and sides to ensure proper collection of water. **NOTE: All flashing shall be continuous, have watertight seams and shall be configured to shed all water to the exterior of the system. Apply a strip of AquaFlash Mesh over the vertical legs of the pan flashing to seal the pan to the jambs.**
- c. The flashing shall extend a minimum of 2 1/2 in (64 mm) down over the face of the Infinity System - Figure 7.

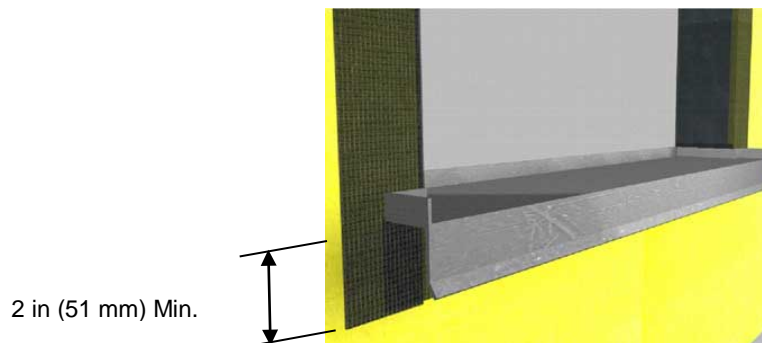

Figure 7

5. Sill Pan Flashing (Concealed) for use with nail-on-windows

- a. Install a watertight pan flashing at all sill locations.
- b. The flashing shall extend between the framing members of the rough opening and shall be sized to protect the sill and sheathing. It must include vertical legs at the back and sides to ensure proper collection of water. It shall extend a minimum of 4 in (102 mm) below the opening and have a sloped horizontal leg which continues over the top edge of the Infinity System. **NOTE: All flashing shall be continuous, have watertight seams and shall be configured to shed all water to the exterior of the system. Apply a strip of AquaFlash Mesh over the vertical legs of the pan flashing to seal the pan to the jambs.**

6. Installation of AquaFlash Over Metal or PVC Flashing Materials

- a. The AquaFlash System may be applied directly over clean galvanized, painted metal, or PVC flashing.
- b. Prepare rough opening as described in Section IV.A.3.
- c. Install flashing material per contract documents.
- d. Clean the surface of the flashing to ensure that it is free of dirt, dust, oil, or other contaminants that may interfere with adhesion. **NOTE: PVC products should be lightly abraded to break the surface skin and provide tooth for the coating.**

- e. Cut AquaFlash Mesh to proper length [flashing plus 4 in (102 mm) extending 2 in (51 mm) beyond each end of flashing] - Figure 8.

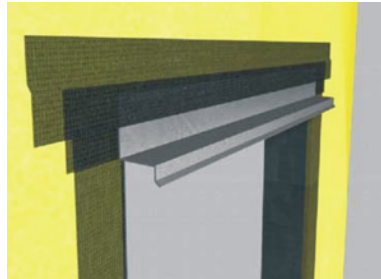

Figure 8

- f. Using a brush or 3/4 in (19 mm) nap roller, apply a liberal coat of AquaFlash Liquid material to the flashing and adjacent air/water-resistive barrier/substrate surface.
- g. Immediately lay the AquaFlash Mesh into the wet material and brush smooth adding additional material to completely embed the mesh.
- h. Allow material to set for fifteen (15) minutes then apply a second liberal coat of AquaFlash Liquid and smooth out to ensure a continuous film free of voids, pinholes, or other discontinuities and allow to dry.

B. Dryvit Backstop NT Option

1. Surface Preparation

- a. Apply only when air and surface temperatures are above 40 °F (4 °C).
- b. The surface to receive the Backstop NT must be clean, dry, smooth and free of any other condition that will hinder adhesion.
- c. Remove loose dust or dirt from the surface by wiping with a clean, dry cloth or brush.

2. Dryvit Backstop NT Application

NOTE: Backstop NT may be applied to the sill of the opening but it must also be covered with either the Dryvit AquaFlash System or Dryvit Flashing Tape.

a. Rough Openings (Windows, Doors, Others)

- 1) Apply Dryvit Grid Tape along the jambs and head of the opening as well as all sheathing joints that may intersect the opening and lap onto face of wall a minimum of 2 in (51 mm). Add additional pieces of Grid Tape at the inside corners (sill/jamb) of the opening to maintain continuity – Figure 9.

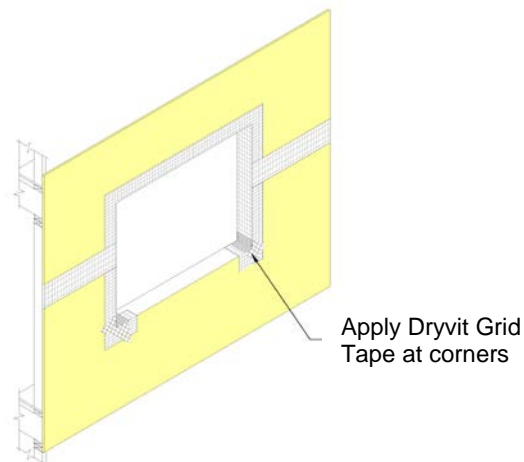

Figure 9

- Using a stainless steel trowel apply Backstop NT – Texture over the Grid Tape extending to the inside face of the opening and onto the face of the exterior sheathing a minimum of 6 in (152 mm) – Figure 10.

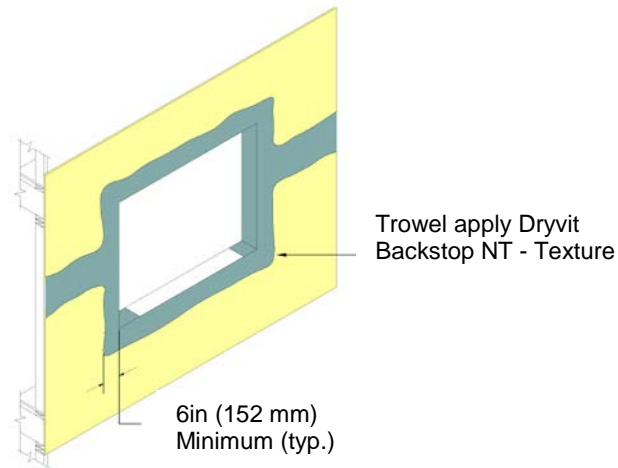

Figure 10

- Apply Dryvit AquaFlash System or Flashing Tape at sill in accordance with Sections IV.A.3 and IV.C respectively. **NOTE: AquaFlash System or Flashing Tape must extend up the jambs a minimum of 4 in (102 mm) – Figure 11.**

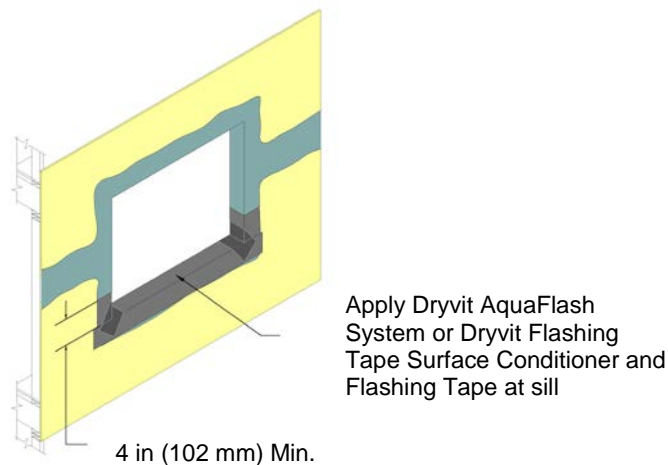

Figure 11

- Install the specified component (i.e. window, etc.) and associated flashings per manufacturer's directions and contract documents. Then apply Backstop NT – Texture or Smooth to the remainder of the wall surface as described in Section VI and lap over the previously installed material (do not lap over Flashing Tape if specified) around openings – Figure 12.

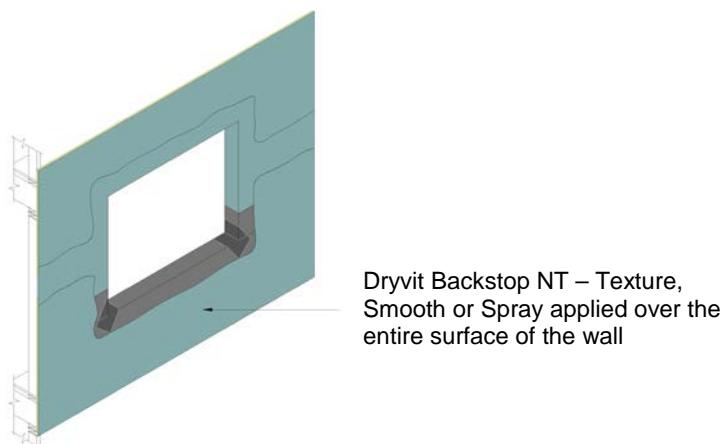

Figure 12

C. Dryvit Flashing Tape Option

Caution: The Dryvit Flashing Tape and Surface Conditioner must be handled properly. Refer to the Material Safety Data Sheets for proper handling, storage, health and environmental considerations.

NOTE: When Dryvit Flashing Tape is specified for rough opening preparation, the air/water-resistive barrier must be installed prior to preparing the opening (see Section VI).

NOTE: Coordinate the Dryvit Flashing Tape application with the insulation board installation. Apply only enough Dryvit Flashing Tape that can be covered with the insulation board in the same work period.

1. Dryvit Flashing Tape must be installed to provide a continuous barrier from the air/water-resistive barrier/sheathing substrate onto the framing edges at discontinuities and terminations such as openings, expansion joints, tops of parapets, etc. Refer to Dryvit Infinity System Installation Details, [DS120](#).
2. Surface Preparation
 - a. Apply only when air and surface temperatures are above 40 °F (4 °C).
 - b. The surface to receive the Dryvit Flashing Tape must be clean, dry, smooth and free of any condition that will hinder adhesion.
 - c. Clean loose dust or dirt from the surface by wiping with a clean, dry cloth or brush.
3. Dryvit Flashing Tape Surface Conditioner Application
 - a. Pour the desired amount of surface conditioner into a clean container to prevent contamination.
 - b. Apply to the surfaces, which are to receive the Dryvit Flashing Tape, using a brush or roller. Sufficient surface conditioner should be applied to condition the surface to a dust free state suitable for the application of the Dryvit Flashing Tape. It should not be applied so heavily that it puddles or runs. Application of excess material will not improve adhesion but will extend the drying time.
 - c. Allow to dry until the surface is slightly tacky. Low temperatures and high humidity conditions may require longer drying times. Conditioning should be limited to areas that can be covered with Dryvit Flashing Tape within the same day.
4. Dryvit Flashing Tape Application
 - a. General
 - 1) Cut the Dryvit Flashing Tape to the appropriate length. Peel the release paper to expose the rubberized asphalt adhesive and align the tape into position before touching the wall.
 - 2) Position the tape on the wall face so that it covers the Backstop NT 2 in (51 mm) and the remainder is turned into the opening.
 - 3) Move along the opening being careful to place the tape as evenly as possible and avoiding fish-mouths along the edges. If wrinkles develop, cut out the affected area and replace.
 - 4) Apply pressure to the tape so that it is firmly in contact with the wall surface. Press the tape into place with a hand roller as soon as possible to ensure continuous and intimate contact with the surface.
 - 5) End laps that occur must maintain a minimum overlap of 2 in (51 mm).
 - 6) Apply Dryvit Flashing Tape so that it completely covers the stud/track and extends to the interior face of the opening. Additional strips of Dryvit Flashing Tape may be needed.
 - 7) Cold weather application may require the use of a heat gun to warm the wall surface in order to obtain good initial adhesion.

b. Sill/jamb intersections and similar conditions

- 1) Apply the Dryvit Flashing Tape as shown in the detail below - Figure 13.
- 2) Apply sill piece first, then apply the corner splice piece. The jamb piece is applied next, lapping over the splice piece.

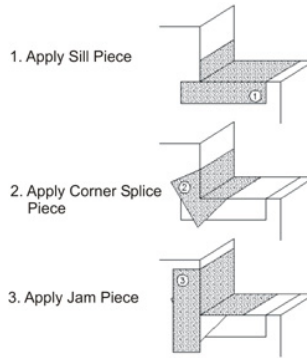

Figure 13

c. Head/jamb intersections

- 1) The jamb pieces are applied first, followed by the corner splice pieces. The head piece is applied last.

d. Lap additional pieces of Dryvit Flashing Tape as necessary to cover the returns to the inside edge of the stud or track.

V. Substrate Expansion Joint Bridging Options

A. AquaFlash System Option

1. Surface Preparation

- a. Apply only when air and surface temperatures are above 40 °F (4 °C).
- b. The surface to receive the AquaFlash System must be clean, dry, smooth and free of any condition that will hinder adhesion.
- c. Clean loose dust or dirt from the surface by wiping with a clean, dry cloth or brush.

2. AquaFlash System Application

- a. The width of the AquaFlash Mesh must overlap each side of the joint a minimum of 2 in (51 mm) - Figure 14.
- b. Clean the joint to allow for the installation of a backer material. Install a closed cell polyethylene backer rod sized a minimum of 50% larger than the joint width. Install so that the backer rod is recessed or projects a minimum of 1/4 in (6.4 mm) from the wall surface.

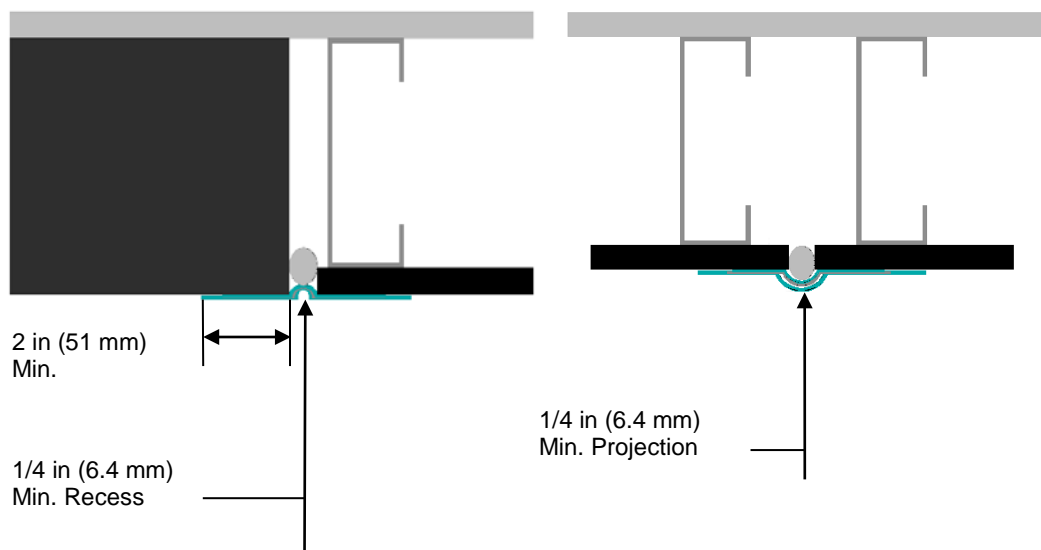

Figure 14

- c. Using a brush or 3/4 in (19 mm) nap roller, apply a liberal coat of AquaFlash Liquid material to the backer rod and adjacent substrate surface to the width of the AquaFlash Mesh - Figure 15.

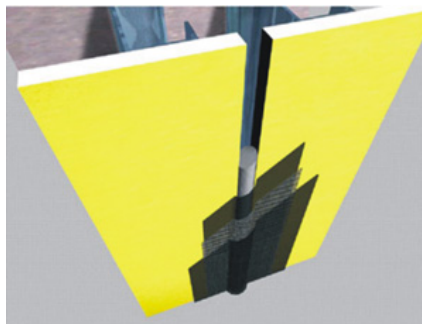

Figure 15

- d. Immediately lay the AquaFlash Mesh into the wet material and brush smooth adding additional material to completely embed the mesh.
- e. Allow material to set for fifteen (15) minutes then apply a second liberal coat of AquaFlash Liquid and smooth out to ensure a continuous film free of voids, pinholes, or other discontinuities.
- B. Dryvit Flashing Tape and Flashing Tape Surface Conditioner Option
- NOTE: When Dryvit Flashing Tape is specified for substrate expansion joint bridging, the water-resistive barrier must be installed prior to preparing the joint (see Section VI).**
- NOTE: Coordinate the Dryvit Flashing Tape application with the insulation board installation. Apply only enough Dryvit Flashing Tape that can be covered with the insulation board in the same work period.**
1. Surface Preparation
 - a. Apply only when air and surface temperatures are above 40 °F (4 °C).
 - b. The surface to receive Dryvit Flashing Tape Surface Conditioner and Dryvit Flashing Tape must be clean, dry, smooth and free of any condition that will hinder adhesion.
 - c. Clean loose dust or dirt from the surface by wiping with a clean, dry cloth or brush.
 2. Dryvit Flashing Tape Surface Conditioner Application
 - a. Pour the desired amount of surface conditioner into a clean container to prevent contamination.
 - b. Apply to the surfaces, which are to receive the Dryvit Flashing Tape, using a brush or roller. Sufficient surface conditioner should be applied to condition the surface to a dust free state suitable for the application of the Dryvit Flashing Tape. It should not be applied so heavily that it puddles or runs. Application of excess material will not improve adhesion but will extend the drying time.
 - c. Allow to dry until the surface is slightly tacky. Low temperatures and high humidity conditions may require longer drying times. Conditioning should be limited to areas that can be covered with Dryvit Flashing Tape within the same day.
 3. Position the Dryvit Flashing Tape so that it is centered over the joint. Adhere to one side of the joint, and then adhere the adjacent side. Allow enough slack in the tape to account for any joint movement.

VI. Air/Water-Resistive Barrier Application

- A. Ensure that the wall surface and ambient temperature are above 40 °F (4 °C) and rising at the time of Backstop NT application. **WARNING: Do not apply the Dryvit materials in the rain. The underlying wall materials and substrate surface must be dry prior to applying the air/water-resistive barrier.**
- B. Sheathing Substrates
1. Prior to applying the Backstop NT over a sheathing substrate, check to ensure that:
 - a. The sheathing is of a type listed in the Infinity System Specification, [DS136](#).
 - b. The sheathing is structurally sound, free of loose material, voids, projections or other conditions that may interfere with the installation of the Infinity System.
 - c. The sheathing is clean, dry, and free of grease, oil, paint and other foreign material.
 - 1) Exterior grade gypsum sheathing facing paper shall not show signs of deterioration and shall be firmly bonded to the core.
 - 2) Plywood or OSB moisture content shall not exceed 19% as measured by a probe type moisture meter.
 - d. There are no planar irregularities greater than 1/4 in (6.4 mm) within any 4 ft (1.2 m) radius. **SHEATHING WITH GAPS OR DAMAGE EXCEEDING 1/4 in (6.4 mm) IN ANY ONE DIRECTION MUST BE REPLACED.**
- NOTE: Notify the general contractor and/or architect and/or owner of all discrepancies. Do not proceed until all unsatisfactory conditions have been corrected.**

NOTE: OSB Sheathing requires that joints and fasteners be treated with Backstop NT – Texture. A minimum of two (2) coats of Backstop NT – Smooth are required for the field of the wall. Backstop NT - Texture is not recommended for application in the field of the board.

C. Concrete or Masonry Substrates

NOTE: Backstop NT - Texture is recommended for use over concrete and masonry.

1. Prior to applying the Backstop NT - Texture over a concrete or masonry substrate, check to ensure that:
 - a. All cracks are repaired using appropriate procedures and materials.
 - b. The substrate is structurally sound, free of loose material, voids, projections or other conditions that may interfere with the installation of the Infinity System.
 - c. The substrate is clean, dry, free of grease, oil, paint, form release agents, efflorescence and other foreign materials that may inhibit adhesion.
 - d. There are no planar irregularities greater than 1/4 in (6.4 mm) within any 4 ft (1.2 m) radius.
 - 1) Mortar joints that are not struck flush or heavily textured masonry units shall be skim coated with Dryvit Genesis or Genesis DM prior to the application of Backstop NT - Texture.
 - a) Mix Genesis or Genesis DM in accordance with Section III.C.1 or III.C.3, respectively.
 - b) With a stainless steel trowel, apply a coat of the Genesis mixture or Genesis DM mixture over the substrate to fill the mortar joints and surface texture to provide a uniform smooth surface for the application of the Backstop NT - Texture.
 - c) Allow the skim coat to completely dry prior to applying the Backstop NT - Texture.

D. Usage Application Chart

Backstop NT (BSNT) - Texture, Smooth, and Spray Usage/Application Chart													
			Approx. Coverage Per Pail	Approx. Coverage Per Drum									
Exterior Grade Gypsum Sheathing													
Joins ^a	BSNT - Texture	Trowel	300 lin. ft (91 m)										
Face ^e	BSNT - Texture	Trowel, FoamPRO #58 Roller ^b or Texture Sprayer	250-300 ft ² (23-28 m ²)										
	BSNT - Smooth ^{c,9}	1/2 in (12.7 mm) Nap Roller or Texture Sprayer	500 ft ² (46 m ²)										
	BSNT - Spray ^j	Airless Spray	500-600 ft ² (46-56 m ²)	5,000-6,000 ft ² (465-557 m ²)									
Fiberglass Faced Exterior Gypsum Sheathing													
Joins ^a	BSNT - Texture	Trowel	300 lin. ft (91 m)										
Face ^e	BSNT - Texture	Trowel or Texture Sprayer	250-300 ft ² (23-28 m ²) [includes joints]										
	BSNT - Smooth ^{c,9}	3/4 in (19 mm) Nap Roller or Texture Sprayer	400 ft ² (37 m ²)										
	BSNT - Spray ^g	Airless Spray	500-600 ft ² (46-56 m ²)	5,000-6,000 ft ² (465-557 m ²)									
Exposure 1, Exterior Grade, and Fire Retardant Treated Plywood; and Exterior Cement Board													
Joins ^a	BSNT - Texture	Trowel	300 lin. ft (91 m)										
Face ^e	BSNT - Texture	Trowel, FoamPRO #58 Roller ^b or Texture Sprayer	250-300 ft ² (23-28 m ²)										
	BSNT - Smooth ^{c,9}	1/2 in (12.7 mm) Nap Roller or Texture Sprayer	400 ft ² (37 m ²)										
	BSNT - Spray ^g	Airless Spray	500-600 ft ² (46-56 m ²)	5,000-6,000 ft ² (465-557 m ²)									
APA Exposure 1 Rated Oriented Strand Board (OSB)													
Joins ^a	BSNT - Texture	Trowel	300 lin. ft (91 m)										
Face ^e	BSNT - Smooth ^g	1/2 in (12.7 mm) Nap Roller or Texture Sprayer	350-400 ft ² (33-37 m ²), applied in 2 coats, backrolled										
	BSNT - Spray ^g	Airless Spray		3,500-4,000 ft ² (325-372 m ²)									
Concrete and Masonry ^{d,9}													
Face	BSNT - Texture	Trowel ^f	200-250 ft ² (19-23 m ²) ^f applied in 1 coat										
	BSNT - Texture	FoamPRO #58 Roller or Texture Sprayer	200-250 ft ² (19-23 m ²) ^f applied in 2 coats, backrolled										
	BSNT - Spray ^g	Airless Spray	300-500 ft (28-46 m ²)	3,000-5,000 ft (279-465 m ²)									
<p>^a Tape the joints with Dryvit Grid Tape prior to application of Backstop NT - Texture at joints and screw heads.</p> <p>^b Up to 1 pint (16 oz) of water may be added to a 60 lb pail of Backstop NT - Texture for roller or spray applications only. The FoamPRO #58 roller cover (FoamPRO Mfg., Inc., www.foampromfg.com) is available at home supply stores.</p> <p>^c Because of application methodology and absorptive surface differences, two coats may be required to obtain this coverage.</p> <p>^d Due to variations in types of concrete/masonry, apply a 6 ft x 6 ft test area with coverage as indicated in the chart, before proceeding with the entire job. If there are voids in the substrate, particularly at the mortar joints, the job should be parged with Genesis[®], 24 hours prior to BSNT - Texture application. Backstop NT shall NOT be used as a skim coat for parging CMU joints or heavy textured units.</p> <p>^e Backstop NT - Texture (with up to 1 pint water addition per 60 lb. pail) or Smooth may be sprayed and backtrowelled/backrolled.</p> <p>^f Coverage may vary depending on the texture and porosity of the substrate. Coverage assumes a smooth, dense surface.</p> <p>^g Backstop NT should be applied at the recommended coverage rates to form a continuous film free of voids, pinholes or other discontinuities. The following approximate mil thicknesses are recommended:</p> <table border="0" style="margin-left: 40px;"> <tr> <td>Backstop NT Texture</td> <td>12 DFT</td> <td>20* WFT</td> </tr> <tr> <td>Backstop NT Smooth</td> <td>12 DFT</td> <td>20* WFT</td> </tr> <tr> <td>Backstop NT Spray</td> <td>9 DFT</td> <td>15* WFT</td> </tr> </table> <p>*Based on volume solids</p>					Backstop NT Texture	12 DFT	20* WFT	Backstop NT Smooth	12 DFT	20* WFT	Backstop NT Spray	9 DFT	15* WFT
Backstop NT Texture	12 DFT	20* WFT											
Backstop NT Smooth	12 DFT	20* WFT											
Backstop NT Spray	9 DFT	15* WFT											

Refer to Product Data Sheets for Complete Mixing and Application Instructions

E. Application of Backstop NT

1. Dryvit Grid Tape (not required with concrete and masonry substrates)
 - a. For sheathing substrates, apply the Dryvit Grid Tape along all joints in the sheathing, as well as inside corners, outside corners, and exposed edges at terminations that will not be covered with Dryvit AquaFlash or Dryvit Flashing Tape.
 - b. Center the Dryvit Grid Tape on the sheathing joints, edges, etc. with the pressure sensitive adhesive backing in contact with the sheathing surface. Press into position with hand pressure until adhesion is achieved.
 - c. Apply only enough Dryvit Grid Tape as can be covered with Backstop NT - Texture in the same day.
2. Dryvit Backstop NT - Texture Application
 - a. General: Backstop NT - Texture can be applied using a roller, trowel or spray equipment over the listed substrates, as noted in the usage chart above. Backstop NT - Texture should be applied at the recommended coverage rate to achieve a continuous film at a minimum dry film thickness of approximately 12 mils (0.3 mm).
 - b. Roller Application
 - 1) Apply Dryvit Grid Tape as described in Section VI.E.1 above. Mix the Backstop NT - Texture material as described in Section III.B.2. Using a stainless steel trowel or spatula, apply a layer of Backstop NT - Texture over the Dryvit Grid Tape and spot all fastener heads – Figure 16. **NOTE: Dryvit Grid Tape is not necessary over fastener heads.**

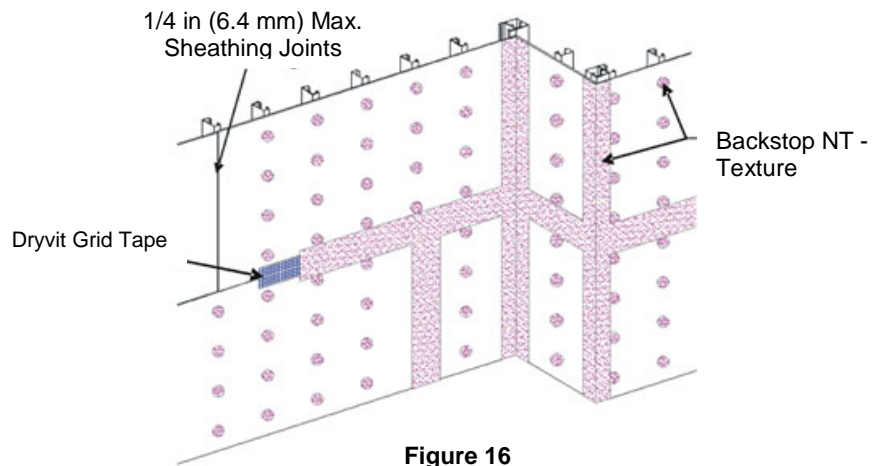

Figure 16

- 2) Allow to dry for a minimum of two (2) hours or until dry to the touch. **NOTE: Cool, humid conditions may require longer drying times**
- 3) Use a coarse, open-cell foam roller cover with a 3/8 in (9.5 mm) foam nap (FoamPRO #58 roller). Apply a uniform, continuous film of Backstop NT – Texture over the entire surface of the sheathing, concrete or masonry, including the previously treated areas – Figure 17. **NOTE: If the roller pulls material back out of the sheathing joints, it indicates that the joint material is not sufficiently dry.**
 - a) For concrete and masonry, ensure that a continuous film of uniform thickness is applied across the entire surface and across mortar joints. Minimum two (2) coats are required allowing a minimum of two 2 hours between coats. Cool, damp weather may require longer time between coats.

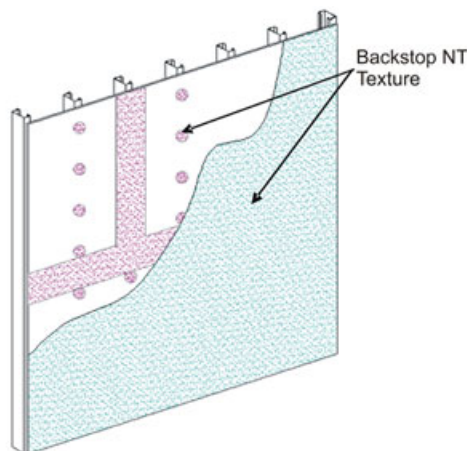

Figure 17

- 4) While the Backstop NT - Texture is still wet, using a trowel or spatula, smooth out the Backstop NT - Texture around all window and door perimeters and other areas that will later receive Dryvit Flashing Tape - Figure 18.

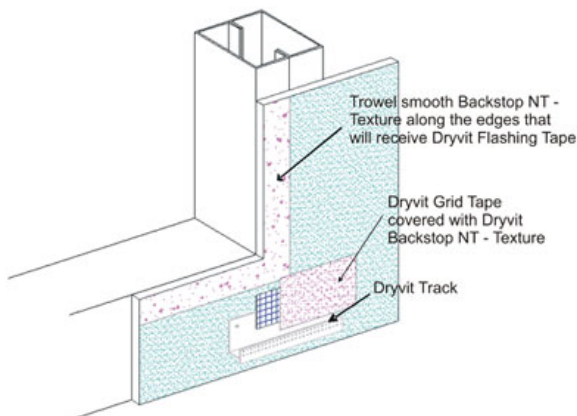

Figure 18

- 5) The Backstop NT - Texture material should be applied in a uniform, continuous film at the recommended coverage rate. **NOTE: Substrates with a surface texture or high porosity will require additional material.**
- c. Trowel Application
- 1) Apply Dryvit Grid Tape as described in Section VI.E.1 above. Mix the material, as described in Section III.B.2, and using a stainless steel trowel or spatula, apply a layer of Backstop NT - Texture over the grid tape. Spotting of fasteners is not necessary when applying Backstop NT - Texture using a trowel. Allow to dry for a minimum of two (2) hours or until dry to the touch. **NOTE: Cool, humid conditions may require longer drying times.**
 - 2) Using a stainless steel trowel, apply a continuous coating of Backstop NT - Texture material onto the entire surface. The material should be applied at a smooth, uniform, continuous film approximately equal to the thickness of the aggregate.
- d. Spray/Back-Rolling Application
- 1) Apply Dryvit Grid Tape as described in Section VI.E.1 above. Mix the material as described in Section III.B.2 and using a stainless steel trowel or spatula, apply a layer of Backstop NT - Texture over the grid tape and spot all fastener heads. Allow to dry for a minimum of 2 hours or until dry to the touch.
 - 2) After the first pass has dried, check the joints and spot any voids that may be present with additional Backstop NT - Texture material and allow to dry.
 - 3) Using a hand held hopper gun or other suitable spray equipment; spray a layer of Backstop NT - Texture onto the wall surface. Using a coarse, open-cell foam roller cover with a 3/8 in (9.5 mm) foam nap (FoamPro #58 roller), roll the material to create a smooth continuous film. **NOTE: If the roller pulls material back out of the sheathing joints, it indicates that the joint material is not sufficiently dry.**
 - 4) While Backstop NT - Texture is still wet, using a trowel or spatula, smooth out the Backstop NT - Texture around all window and door perimeters and other areas that will later receive Dryvit Flashing Tape - Figure 18.
 - 5) Backstop NT - Texture material should be applied in a uniform, continuous film at the recommended coverage rate. **NOTE: Substrates with a surface texture or high porosity will require additional material.**
- e. Allow the Backstop NT - Texture to completely dry prior to installation of the Infinity System.
3. Backstop NT - Smooth Application
- a. General: Dryvit Backstop NT - Smooth can be applied using a roller or sprayed and back-rolled over the acceptable sheathing substrates. **NOTE: OSB sheathing requires that joint and fasteners be treated with Backstop NT - Texture. A minimum of two (2) coats of Backstop NT - Smooth are required for the field of the wall. Backstop NT - Texture is not recommended for application in the field of the board.**
 - b. Sheathing Substrates: All fastener heads shall be spotted and joints treated with Backstop NT - Texture and Dryvit Grid Tape, prior to Backstop NT - Smooth application, in accordance with Section VI.E.2.
 - c. Roller Application
 - 1) Using the appropriate nap roller (see Usage Application Chart), apply the Backstop NT - Smooth over the entire wall surface, including previously treated joints. **NOTE: If the roller pulls material back out of the sheathing joints, it indicates that the joint material is not sufficiently dry.**

- 2) Backstop NT - Smooth material should be applied in a uniform, continuous film at the recommended coverage rate – Figure 19. **NOTE: Sheathing substrates with a surface texture or high porosity will require additional material.**

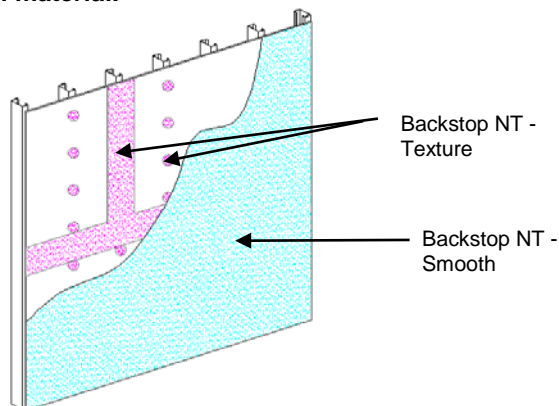

Figure 19

d. Spray/Back-Rolling Application

- 1) Backstop NT - Smooth may be applied to the wall using spray equipment and back-rolled using the appropriate nap roller (see Usage Application Chart).
- 2) Allow the Backstop NT – Smooth to completely dry. Check the wall to ensure that the Backstop NT - Smooth is continuous and spot any visible voids with additional Backstop NT - Smooth material.

VII. Accessories

A. Preparation

1. The Dryvit Starter Strip, Dryvit Vent Assembly and Dryvit Vent Track are required along the base of walls and horizontal compartments.
 - a. Provide a permanent or temporary support for the Dryvit Starter Strip and Dryvit Vent Assembly and mark the location of the vent assembly along the base of the wall. Vent assemblies should be spaced every 10 ft (3 m) along the base of the wall and horizontal compartments to match the slot locations in the Dryvit Vent Track. **NOTE: Holes, created by fasteners used for temporary supports that penetrate the Backstop NT air/water-resistive barrier, AquaFlash System, or flashing tape, must be sealed with additional Backstop NT mixture, AquaFlash System, or flashing tape prior to adhering the I.S. Insulation Board and Closure Blocks.**
2. The Dryvit Starter Strip and Dryvit Track are required at the heads of all openings.
 - a. Because insulation board joints cannot align with corners of openings, first cut L-shaped pieces of starter strip for the corners of the opening. Then measure and cut the Dryvit Starter Strip to the proper length to fit between the corner pieces over the opening.
 - b. Measure and cut the Dryvit Track so that it extends beyond the edges of the opening to the closest vertical groove in the insulation board. Refer to Dryvit Infinity System Installation Details, [DS120](#).

B. Installation

1. Begin installation from a permanent or temporary support.
2. Mix the Dryvit adhesive in accordance with Section III.C. **WARNING: Do not apply the Dryvit materials in the rain. The air/water-resistive barrier surface must be clean and dry prior to adhering the insulation board.**
3. Cut the Detail Mesh to a working length.
4. Apply a ribbon of adhesive mixture on the substrate and position the Detail Mesh in the wet mixture allowing for a 2 1/2 in (64 mm) minimum overlap onto the face of the starter strip and vent assembly. Keep the mesh, which is not embedded, clean.
5. Apply the adhesive mixture to the backside of the Dryvit Starter Strip and Dryvit Vent Assembly using a ribbon and dab pattern, and position on the wall. Press gently and slide into position applying uniform pressure to ensure full contact and high initial grab.
6. Using a margin trowel, remove any adhesive from the edges of the insulation boards that will abut other insulation boards. **CAUTION: Do not allow adhesive to remain in board joints. Ensure that the insulation board joints are abutted tightly and are level and flush.**

7. Install the Dryvit Vent Track and Dryvit Track by applying a continuous horizontal bead of Dryvit's AP Adhesive on the wall side of the vertical nailing flange of the track and position over the Dryvit Starter Strip. When installing the Dryvit Vent Track the cut out (slot) must be located directly above the Dryvit Vent Assembly – Figure 20. Press firmly against the substrate to ensure firm and continuous contact between the adhesive and the wall surface. **NOTE: It is recommended that the surface of the Drainage Track and Vent Track be lightly sanded to improve adhesion of Backstop NT or AquaFlash.**

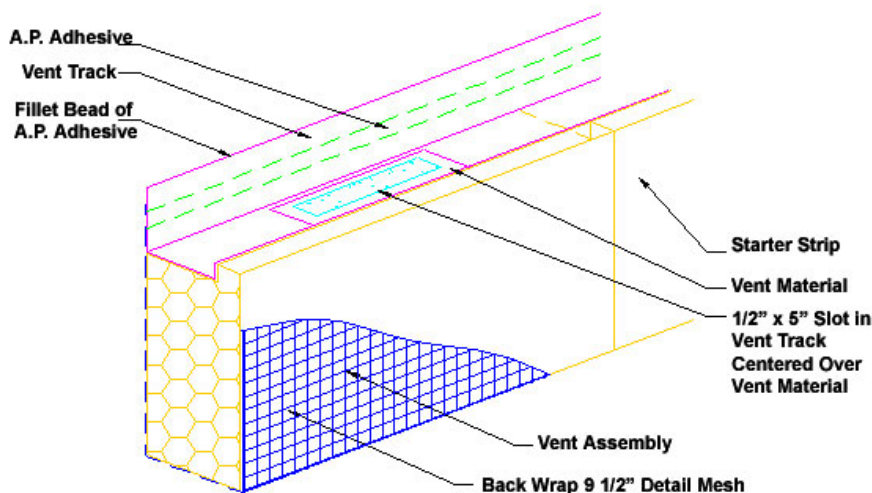

Figure 20

8. Place a continuous bead of AP Adhesive where pieces of track abut each other, to provide a seal.
 9. Apply a bead of AP Adhesive to fill the track at each compartment separation to close off the compartment.
 10. Install the AquaFlash System, Backstop NT and Grid Tape or Flashing Tape on the flange of the Dryvit Vent Track and the adjacent wall in order to ensure water-tightness at the flange/wall interface. See Section IV for proper application.

VIII. Installation of I.S. Closure Blocks

- A. Prior to installing the I.S. Closure Blocks, check to ensure that:
1. They are shipped in a polyethylene bag bearing the Dryvit name. In addition, the lot number of the insulation board is visible on the outside of the bag. Insulation board shall be obtained from Dryvit Systems, Inc. or its authorized distributors and made exclusively by manufacturers licensed by Dryvit Systems, Inc.
 2. One edge of each board bears the word Dryvit, the plant identification number of the block molder, the appropriate model code report number, and the name of the third-party quality control agency with corresponding number. In addition, one board in each bag shall bear the same markings on the face.
 3. The I.S. Closure Blocks measure between 6 in (152 mm) and 12 in (305 mm) in width by 4 ft (1219 mm) in length. The minimum thickness is 2 in (51 mm).
 4. The insulation board meets the following tolerances:
 - a. Length: Plus or minus 1/16 in (1.6 mm).
 - b. Width: Plus or minus 1/16 in (1.6 mm).
 - c. Thickness: Plus or minus 1/16 in (1.6 mm) for boards 2 in (51 mm) and greater.
 - d. Squareness: Shall not deviate from square by more than 1/32 in (0.8 mm) in 12 in (305 mm) of total length or width.
 - e. Edge Trueness: Shall not deviate more than 1/32 in (0.8 mm) in 12 in (305 mm).
 - f. Face Flatness: Shall not exhibit any bowing of more than 1/32 in (0.8 mm) in the length.

WARNING: Any insulation board, closure block or starter strip not meeting the above requirements should be rejected and not installed.
 5. The surface of the Backstop NT is uniform in thickness, continuous, clean, dry and free of efflorescence and any other foreign materials that will affect adhesion of the insulation board.

B. Dryvit Adhesive Application

1. Mix the Dryvit adhesive in accordance with Section III.C

a. Cementitious Adhesive

1) Notched Trowel Method

a) Using a stainless steel trowel, install a ribbon of the adhesive mixture, 2 in (51 mm) wide by 3/8 in (9.5 mm) thick around the entire perimeter of the insulation board. Place eight (8) dabs of the adhesive mixture 3/8 in (9.5 mm) thick by 4 in (102 mm) in diameter approximately 8 in (203 mm) on center to the interior area of the insulation board. **NOTE: The ribbon and dab method of applying the adhesive mixture is only acceptable when applying Dryvit Starter Strips, Vent Assemblies and Closure Blocks. Notched trowel is not to be used with Closure Blocks.**

b. Non-cementitious Adhesive

1) AP Adhesive - recommended for use in limited areas only, such as metal surfaces, including steel lintels, metal flashing, etc.

a) Cut the smallest opening possible in spout (just large enough so adhesive can flow easily when gunned). It is intended to be applied in thin beads [approximately 3/8 in (9.5 mm)].

C. Vertical Boundaries

1. Vertical compartment boundaries are located by the designer and should be noted in the contract documents.

a. Strike a chalk line on the Backstop NT to mark the location of the vertical compartment boundaries as shown in the contract documents.

b. Apply the Dryvit Adhesive mixture to the back of the I.S. Closure Blocks using a ribbon and dab adhesive pattern as shown in Figure 21 and position along the compartment separation line as shown in Figure 22.

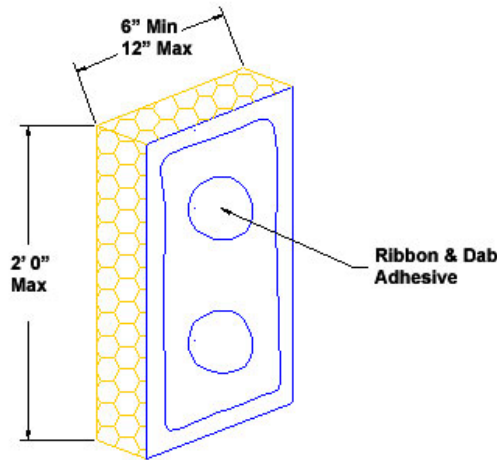

Figure 21

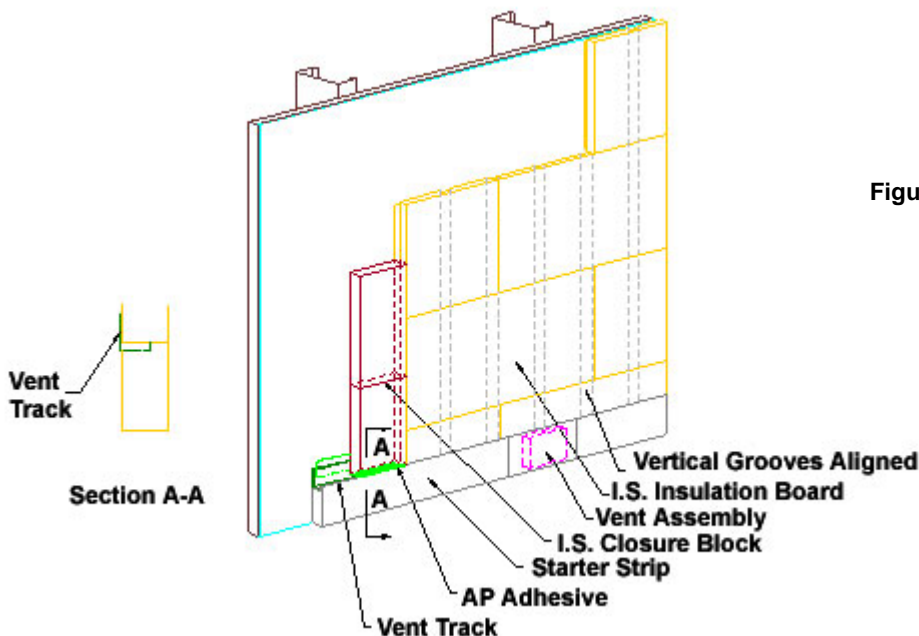

Figure 22

D. Openings and Tops of Compartments

1. Install 6 in (152 mm) wide I.S. Closure Blocks around all openings and tops of compartments. Install 12 in (305 mm) wide Closure Blocks on alternating sides of outside corners (see Figure 27), at vertical compartment boundaries (see Section VIII.C), and vertical system terminations.
2. Jambs, sills, tops of compartments and vertical system terminations
 - a. Cut Detail Mesh to a working length.
 - b. Apply a ribbon of adhesive mixture on the substrate and embed the Detail Mesh into the wet mixture. Position the Detail Mesh on the wall allowing for a 2 1/2 in (64 mm) minimum overlap onto the face of the I.S. Closure blocks. Keep the mesh which is not embedded clean.
 - c. Apply the adhesive mixture to the back side of the I.S. Closure Blocks using a ribbon and dab pattern as shown in Figure 23 and position on the wall.

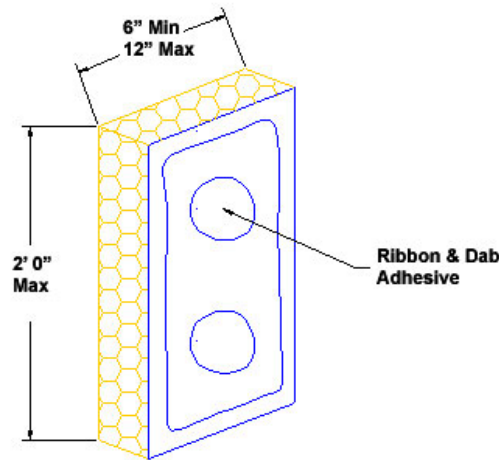

Figure 23

3. Heads of Openings

- a. Because insulation board joints cannot align with corners of openings, first cut L-shaped pieces of starter strip for the corners of the opening. Then measure and cut the Dryvit Starter Strip to the proper length to fit between the corner pieces over the opening.
- b. Mix the adhesive material as described in Section III.C.
- c. Cut Detail Mesh to a working length.
- d. Apply a ribbon of adhesive mixture on the substrate and position the Detail Mesh in the wet mixture allowing for a 2 1/2 in (64 mm) minimum overlap onto the face of the Starter Strip. Keep the mesh, which is not embedded, clean.
- e. Notch the top of the I.S. Closure Block to accept the Dryvit Track, as shown in Figure 24. **NOTE: Dryvit Starter Strips can be used above windows, doors, etc.** This will minimize the required field notching to only L-shaped closure blocks at the corners.
- f. Apply the adhesive mixture to the back side of the I.S. Closure Blocks/Starter Strips using a ribbon and dab pattern as shown in Figure 23 and position on the wall.

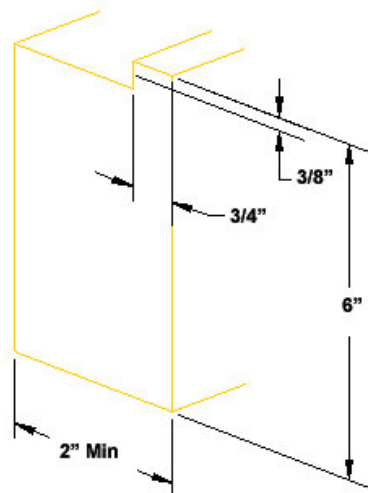

Figure 24

- g. Using a margin trowel, remove any adhesive from the edges of the Dryvit Starter Strip that will abut other Starter Strips. **CAUTION: Do not allow adhesive to remain in board joints. Ensure that the Starter Strip joints are abutted tightly and are level and flush.**
- h. Offset the joints of the I.S. Closure Blocks a minimum of 6 in (152 mm) from the corner of the opening by using an L-shaped closure block at each corner as shown in Figure 25.

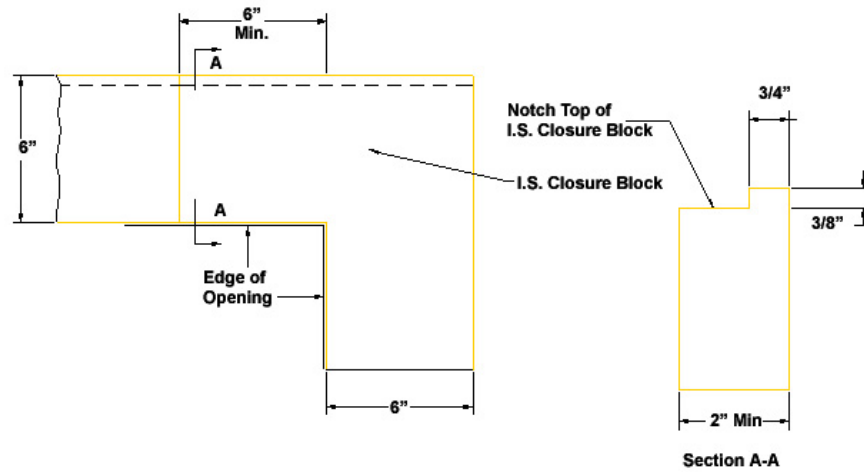

Figure 25

- i. Cut a piece of Dryvit Track to length so that it extends 1/4 in (6.4 mm) beyond the edge of the Closure Blocks as shown in Figure 26. **NOTE: The Dryvit Track must be continuous. Do not splice!**

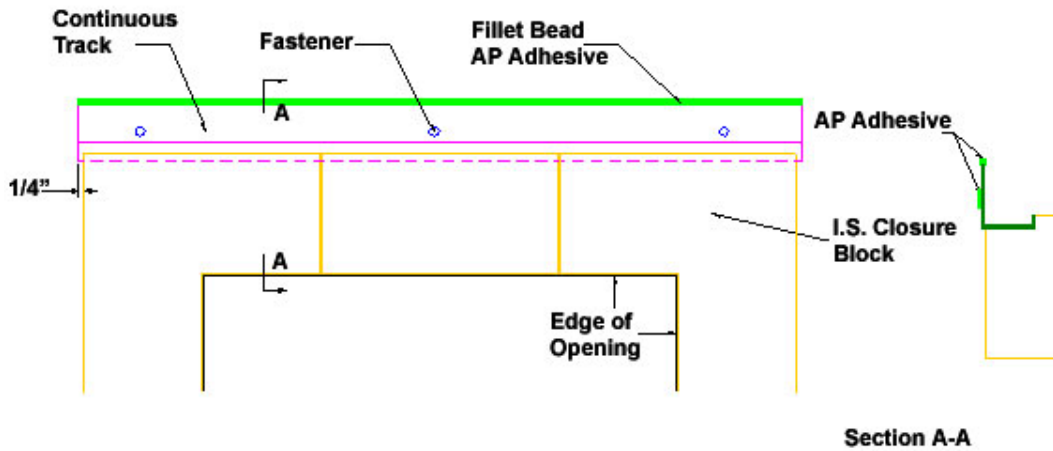

Figure 26

- j. Install the Dryvit Track by applying a continuous bead of Dryvit AP Adhesive on the wall side of the vertical flange of the track and position over the Dryvit Starter Strip. Press firmly against the substrate to ensure firm and continuous contact between the adhesive and the wall surface. Additionally, secure with fasteners once track is in position. **NOTE: It is recommended that the surface of the track be lightly sanded to improve adhesion of Backstop NT or AquaFlash.**
- k. Install the AquaFlash System, Backstop NT and Grid Tape or Flashing Tape on the flange of the Dryvit Vent Track and the adjacent wall in order to ensure water-tightness at the flange/wall interface. See Section IV for proper application.

4. Inside and Outside Corners

- a. Install 12 in (305 mm) wide I.S. Closure Blocks on alternating sides of inside and outside corners as shown in Figure 27.

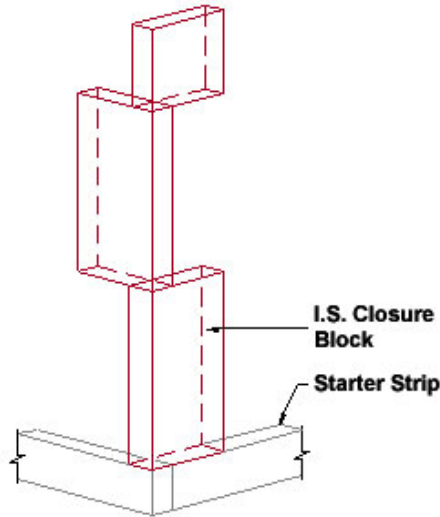

Figure 27

- b. Apply the adhesive mixture to the back side of the I.S. Closure Block using a ribbon and dab pattern. When installing I.S. Closure Blocks on outside corners, hold the adhesive mixture back from the edge of the board by the thickness of the foam and position on the wall as shown in Figure 28.

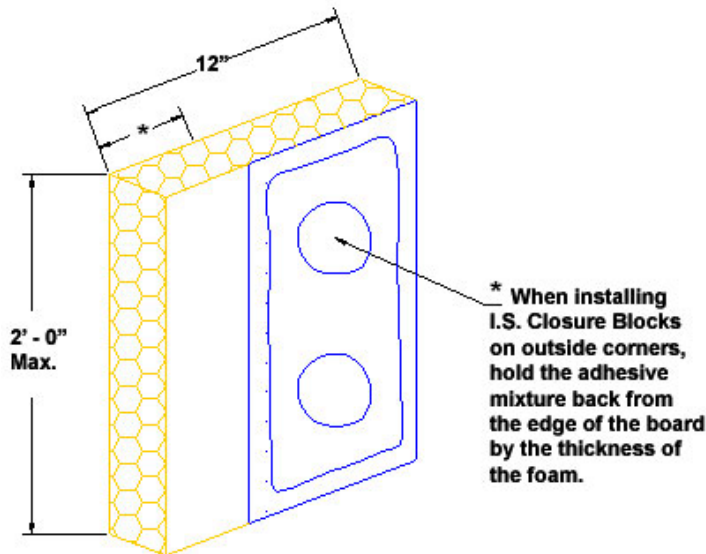

Figure 28

IX. Installation of I.S. Insulation Board

A. Inspection

- 1. Prior to installing the I.S. Insulation Board, check to ensure that:
 - a. They are shipped in a polyethylene bag bearing the Dryvit name. In addition, the lot number of the insulation board is visible on the outside of the bag. Insulation board was obtained from Dryvit systems, Inc. or its authorized distributors and made exclusively by manufacturers licensed by Dryvit systems, Inc.
 - b. One edge of each board bears the word Dryvit, the plant identification number of the block molder, the appropriate model code report number, and the name of the third-party quality control agency with corresponding number. In addition, one board in each bag bears the same marking on the face.

- c. The insulation board meets the following tolerances:
 - 1) Length: Plus or minus 1/16 in (1.6 mm).
 - 2) Width: Plus or minus 1/16 in (1.6 mm).
 - 3) Thickness: Plus or minus 1/16 in (1.6 mm) for boards 2 in (51 mm) and greater.
 - 4) Squareness: Shall not deviate from square by more than 1/32 in (0.8 mm) in 12 in (305 mm) of total length and width.
 - 5) Edge trueness: Shall not deviate more than 1/32 in (0.8 mm) in 12 in (305 mm).
 - 6) Face flatness: Shall not exhibit any bowing of more than 1/32 in (0.8 mm) in 12 in (305 mm).

WARNING: Any I.S. Insulation Board not meeting the above requirements should be rejected and not installed.

- 2. The I.S. Insulation Board measures a maximum of 2 ft (610 mm) by 4 ft (1219 mm) with a minimum thickness of 2 in (51 mm).
 - 3. The back side of the I.S. Insulation Board has vertical grooves and bevels as show in the Dryvit Infinity System Installation Details, [DS120](#).
 - 4. The surface of the Backstop NT is uniform in thickness, continuous, clean, dry and free of efflorescence and other foreign materials that will affect adhesion of the insulation board.
- B. Dryvit Adhesive Application
- 1. Mix the Dryvit adhesive in accordance with Section III.C.

a. Cementitious Adhesive

1) Notched Trowel Method

- a) With a notched trowel, 3/8 in (9.5 mm) wide, 1/2 in (12.7 m) deep notches spaced 1 1/2 in (38 mm) apart, apply the adhesive mixture to the back side of the insulation board. Holding the trowel at a 45° angle, apply firm pressure to the insulation board in order to scrape the excess adhesive from between the adhesive beads. **NOTE: Apply the adhesive so that the ribbons run vertically when the insulation board is placed on the wall. Notched trowel is not to be used when adhering Closure Blocks.**

C. Insulation Board Installation

- 1. Apply the adhesive to the back side of the insulation board as described in Section IX.B.1.a.1)a).
- 2. Beginning at the base of the wall (above the Dryvit Starter Strip), install the I.S. Insulation Boards with their long edges oriented horizontally. Locate the insulation boards so that joints are offset from the sheathing board joints a minimum of 8 in (203 mm) in both vertical and horizontal directions.
- 3. Position the I.S. Insulation Board horizontally on the substrate. Press the board gently to the substrate and slide it into position. Apply firm pressure over the entire surface of the insulation board to ensure uniform contact and high initial grab.
- 4. Using a margin trowel, clean the insulation board edges of any adhesive mixture. Ensure that the I. S. Insulation Board joints are butted tightly and faces are level and flush. **CAUTION: Do not allow adhesive to remain in board joints.**
- 5. Install subsequent rows of insulation board in a running bond pattern (vertical joints staggered) as shown in Figure 29.

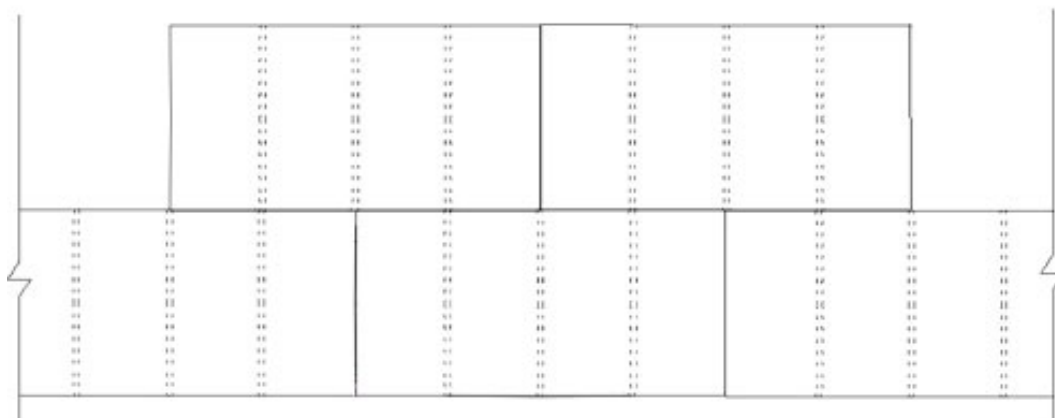

Figure 29

- 6. To ensure an overall flat surface, tamp the insulation board surface with a board that overlaps two to four rows of insulation.

7. Tops of walls, sills of continuous windows and other horizontal system terminations are terminated using 6 in or 12 in x 48 in (152 mm or 305 mm x 1.2 m) I.S. Closure Blocks. These are adhered to Backstop NT using a ribbon and dab adhesive pattern as shown in the Figure 30.

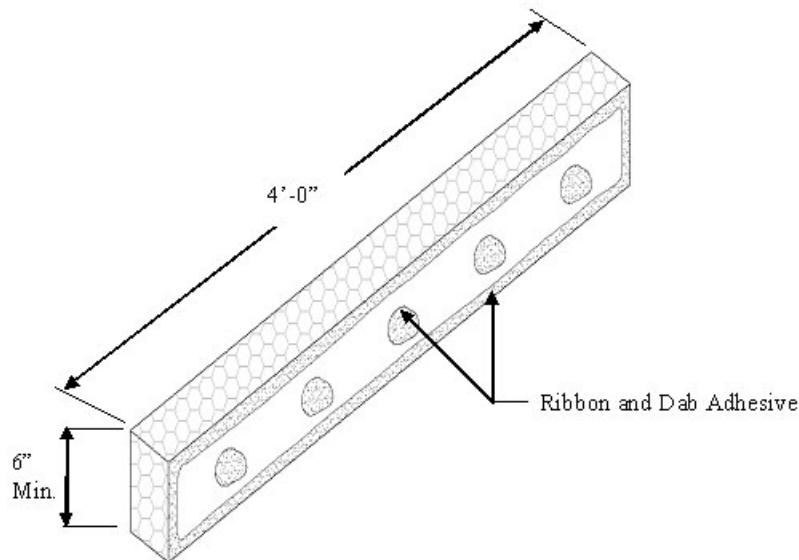

Figure 30

8. If for any reason the I.S. Insulation Board joints are not butted tightly, slivers of insulation board must be installed to fill any gaps. **ALL GAPS GREATER THAN 1/16 in (1.6 mm) MUST BE SLIVERED. Tip: In order to create a tight fit, it is recommended that a wider joint be cut with a hot groover or similar tool to allow for a more precise fitting sliver. Do not install adhesive on sliver edges.**
9. Windows, Doors, Mechanical Equipment and all Wall Penetrations
 - a. At penetrations, align the I.S. Closure Blocks so that the edges (vertical and horizontal joints) do not coincide with the corners of the opening as illustrated in Figure 31.

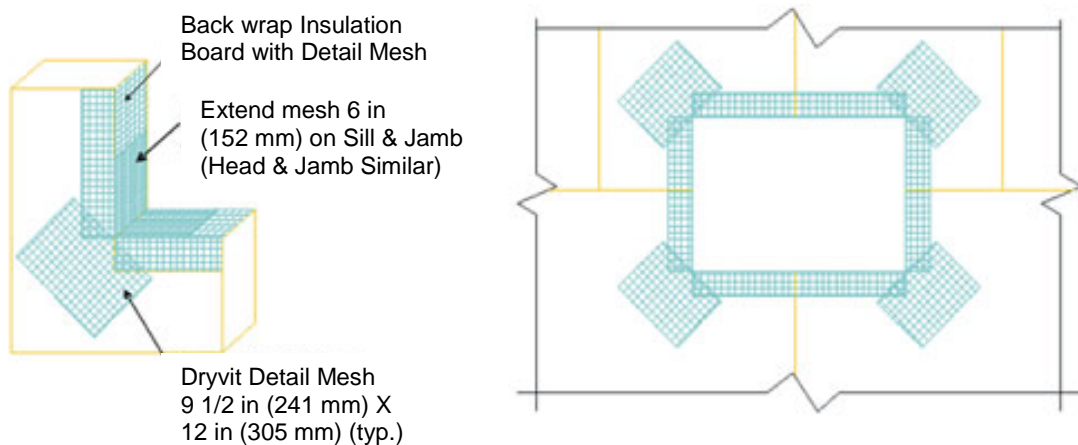

Figure 31

- b. Attach Detail Mesh around the perimeter of the opening as described in Section VIII.D.2 and 3.
 - c. Hold the insulation board back from the window/door frame or mechanical equipment to allow for differential movement, proper system edge preparation, and sealant installation as shown in the Dryvit Infinity System Installation Details, [DS120](#).
10. Expansion Joints
 - a. Attach Detail Mesh on each side of the expansion joint by stapling or applying a ribbon of adhesive mixture on the substrate and embedding the Detail Mesh into the wet mixture.
 - b. Position the Detail Mesh so that a minimum of 2 1/2 in (64 mm) will extend onto the face of the insulation board. Keep the mesh, which is not embedded, clean.

- c. When abutting dissimilar materials, leave a minimum 3/4 in (19 mm) separation between the insulation board and abutting material to allow for differential movement, proper system edge preparation and sealant installation.
 - d. When the Infinity System is installed at a substrate transition, leave a minimum 3/4 in (19 mm) separation between the insulation boards to allow for differential movement, proper system edge preparation and sealant installation.
11. Once the I. S. Closure Blocks and I.S. Insulation Board are in place, wait a minimum of twenty-four (24) hours prior to working on the surface to prevent any movement which may weaken the bond of the adhesive mixture to the substrate. **NOTE: Be sure to protect the installed insulation board from rain, freezing or inclement weather for a period of twenty-four (24).**
 12. Any irregularities in the insulation board surface must be sanded flat. Sanding is accomplished with a light circular motion. **The entire wall area must be sanded.** Use grade 20 grit sandpaper or coarser, in conjunction with hand, electric or air rasps. **NOTE: Do not sand parallel to the insulation board joints. CAUTION: The contractor shall take precautions to contain EPS dust from rasping operation in accordance with contract documents. Use of vacuum rasps are recommended to minimize introduction of EPS dust into the environment.**
 13. Remove all loose pieces of insulation board and dust from the sanding operation using a brush, or compressed air. Use OSHA required masks to protect against inhaling EPS dust.
 14. All Detail Mesh that was previously installed for back wrapping the insulation board shall be embedded in the I.S. Base material mixture at this time.
 - a. With a stainless steel trowel, apply the I. S. Base material mixture to the face (and edge if not previously coated) of the insulation board and embed the Detail Mesh in the wet mixture.
 15. Aesthetic Reveals

NOTE: Insulation board thickness may need to be increased to accommodate reveals and maintain minimum 3/4 in (19 mm) thickness of EPS at all locations.

 - a. To install an aesthetic reveal, snap a straight line using a chalk line to mark the position.
 - b. Position a straight edge such as a steel stud or track against the insulation board in the proper location to guide the appropriate cutting tool (router, hot knife, or hot groover).
 - c. Use Detail Mesh to ensure continuity of reinforcing mesh through aesthetic reveals continuing a minimum of 2 1/2 in (64 mm) on each side of the reveal.
 - 1) Apply the I.S. Base material mixture in the reveal and on the adjacent insulation board surfaces.
 - 2) Embed the Detail Mesh into the I.S. Base Coat mixture on one side of the reveal only.
 - 3) Use a sled or special tool configured to the profile of the reveal. Embed the Detail Mesh into the I. S. Base Coat mixture through the reveal being careful not to cut the mesh.
 - 4) Embed the Detail Mesh into the I.S. Base Coat mixture on the other side of the reveal. Ensure that the mesh is fully embedded and that all excess material is removed from the reveal.
 - 5) Using a damp brush, smooth out any irregularities in the I.S. Base Coat.**CAUTION: If the mesh is cut in the reveal, a new piece of mesh must be installed over the cut.**
 16. Where Corner Mesh is specified for additional impact resistance at outside corners, the Corner Mesh shall be embedded in the I.S. Base Coat mixture and allowed to set prior to installing the overall reinforced base coat over the face of the wall.
 17. Corners of all openings such as windows, doors, mechanical equipment and all penetrations shall be reinforced with Detail Mesh placed diagonally to the opening as illustrated in Figure 31 previously.

X. Installation of Reinforcing Mesh and I.S. Base Coat

A. General

1. **Do not apply the Dryvit materials in the rain. The I.S. Insulation Board must be dry prior to applying the I.S. Base Coat material.**
2. Prior to installing the reinforced I.S. Base Coat, inspect the surface of the I.S. Insulation Board for:
 - a. Flatness: Use a minimum 8 ft (2.4 m) straight edge. Sand any high areas and out-of-plane board joints flat, as described in Section IX.C.12 and 13. **CAUTION: Do not build up low areas with I.S. Base Coat mixture to form a flat surface.**
 - b. Damage and foreign materials: correct deficiencies as necessary.
 - c. Surface degradation due to weathering or UV, visible as discoloration. Sand affected areas to remove deterioration while maintaining the flatness of the surface.

B. Mix the I.S. Base Coat material as described in Section III.D.

C. Prior to installing the reinforcing mesh, it should be inspected to ensure that it has been furnished by Dryvit Systems, Inc.

1. Dryvit reinforcing mesh is available in the following widths and lengths:
 - a. I.S. Reinforcing Mesh - 48 in x 39.5 yd (1.2 m x 36.1 m) – gray in color.
 - b. Panzer 15 - 48 in x 75 ft (1.2 m x 22.9 m)
 - c. Panzer 20 - 48 in x 75 ft (1.2 m x 22.9 m)

- d. Corner - 9 1/4 in x 150 ft (235 mm x 45.7 m)
- e. Detail - 9 1/2 in x 150 ft (241 mm x 45.7 m)

D. Base Coat Application

1. Standard Base Coat (single layer of I.S. Mesh)

- a. The I.S. Base Coat shall be applied such that the resulting overall minimum base coat thickness is sufficient to **fully embed** the reinforcing mesh. The recommended method is to apply the base coat in two (2) passes.
- b. Double pass method (recommended)
 - 1) Using a stainless steel trowel, apply the I.S. Base Coat mixture on the entire surface of the insulation board to an area slightly larger than the width and length of a piece of reinforcing mesh, in a uniform thickness of 1/16 in (1.6 mm). **NOTE: The I.S. Reinforcing Mesh may be installed either vertically or horizontally.**
 - 2) Immediately place the I.S. Reinforcing Mesh against the wet I.S. Base Coat mixture. With the curve of the I.S. Mesh against the wall, trowel from the center to the edges avoiding wrinkles, until the I.S. Mesh is fully embedded and not visible. Trowel smooth to a uniform thickness slightly more than the thickness of the reinforcing mesh. **NOTE: The I.S. Reinforcing Mesh shall be continuous at corners and mesh edges lapped not less than 2 1/2 in (64 mm). Do not lap the I.S. Reinforcing Mesh within 8 in (203 mm) of a corner. Tip: Corners and edges normally require light strokes with a small damp brush to smooth out irregularities.**
 - 3) Allow the I.S. Base Coat mixture to take up until firm to the touch. Trowel a second tight coat of the I.S. Base Coat mixture over the first coat to **fully cover** the I.S. Reinforcing Mesh - Figure 32. The result should be such that the I.S. Reinforcing Mesh is approximately centered within the I.S. Base Coat thickness. Do not allow the first pass to completely dry prior to the second pass application or an excessive amount of the I.S. Base Coat mixture will be necessary to fully coat the wall surface.

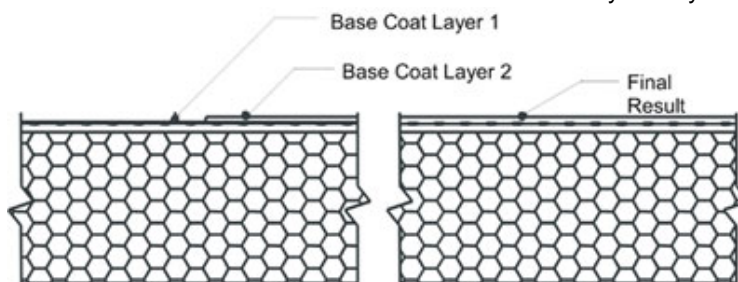

Figure 32

c. Single pass method (optional)

- 1) Using a stainless steel trowel, apply the I.S. Base Coat mixture on the entire surface of the I.S. Insulation board to an area slightly larger than the width and length of a piece of I.S. Reinforcing Mesh, in a uniform thickness of 1/16 in (1.6 mm). **NOTE: The I.S. Reinforcing Mesh may be installed either vertically or horizontally.**
- 2) Immediately place the I.S. Reinforcing Mesh against the wet I.S. Base Coat mixture. With the curve of the I.S. Mesh against the wall, trowel from the center to the edges avoiding wrinkles, until the I.S. Mesh is fully embedded and not visible. Trowel smooth to a uniform thickness slightly more than the thickness of the I.S. Reinforcing Mesh. **NOTE: The I.S. Reinforcing Mesh shall be continuous at corners and mesh edges lapped not less than 2 1/2 in (64 mm). Do not lap the I.S. Reinforcing Mesh within 8 in (203 mm) of a corner. Tip: Corners and edges normally require light strokes with a small damp brush to smooth out irregularities.**

d. Protect completed work from water penetration and runoff.

e. Allow the I.S. Base Coat to cure a minimum of 24 hours before proceeding with application of finish coat.

Cool, damp conditions may require longer drying times. Do not apply finish to a wet or damp I.S. Base Coat.

2. Panzer Mesh Base Coat (Panzer 15 or Panzer 20 used in conjunction with I.S. Reinforcing Mesh). **Panzer Mesh is recommended for use at all ground floor locations and at high traffic areas. Refer to contract documents.**

- a. Using a stainless steel trowel, apply the I.S. Base Coat mixture on the entire surface of the I.S. Insulation Board to an area slightly larger than the width and length of a piece of Panzer Mesh, in a uniform thickness of approximately 1/8 in (3.2 mm).
- b. Immediately place the Panzer Mesh against the wet I.S. Base Coat mixture. With the curve of the Panzer Mesh against the wall, trowel from the center to the edges avoiding wrinkles until the Panzer Mesh is fully covered and not visible.
- c. Continue in the same manner until the entire area requiring Panzer Mesh is covered.
CAUTION: Do not lap the Panzer Mesh. Adjacent pieces are to be tightly butted.
- d. Protect completed work from water penetration and runoff.

- e. Allow the Panzer base coat to cure a minimum of 24 hours prior to applying I.S. Reinforcing Mesh.
- f. Apply the I.S. Reinforcing Mesh in accordance with Section X.D.1.c. Offset the edges of the I.S. Reinforcing Mesh from the edges of the Panzer Mesh a minimum of 8 in (203 mm). **Tip: If Panzer Mesh is installed horizontally, we recommend the I.S. Reinforcing Mesh be installed vertically and vice versa.**

XI. Sealant Joint Preparation

- A. All Infinity I.S. Base Coat surfaces which will be in contact with sealant must be coated with either Color Prime or Demandit Smooth.
 1. Mix Color Prime or Demandit Smooth in accordance with Section III.E and H, respectively.
 2. Using a small brush, apply Color Prime or Demandit to the I.S. Base Coat surface that is to be in contact with the sealant and extending to the joint edge.
 3. Allow the Color Prime or Demandit Smooth to dry a minimum of 48 hours prior to applying the sealant. Cool damp weather may require longer drying times.
 4. Refer to sealant manufacturer's installation instructions for the proper application of the sealant and sealant primer.

XII. Dryvit Primers

- A. Prior to applying the Dryvit primers, the I.S. Base Coat shall have cured a minimum of twenty-four (24) hours and shall be dry and hard. Cure time may be longer depending on environmental conditions. **NOTE: Refer to Product Data Sheets when applying over other materials.**
- B. Inspect the I.S. Base Coat for any irregularities such as trowel marks, board lines, rough corners and edges, improper reinforcing mesh embedment as well as efflorescence. **NOTE: Correct all irregularities and remove all efflorescence prior to applying the Dryvit primer.**
- C. Mix primers to a smooth homogeneous consistency in accordance with Section III.E.
- D. Color Prime
 1. Apply with a brush, roller, or airless spray equipment. Refer to Color Prime Data Sheets, [DS410](#), for complete instructions.
- E. Color Prime W
 1. Application with airless spray equipment is recommended. Refer to Color Prime W Data Sheet, [DS474](#), for complete instructions.
- F. Primer with Sand
 1. Application with a roller is recommended. Refer to Primer with Sand Data Sheet, [DS477](#), for complete instructions.

XIII. Dryvit Finish

- A. Prior to applying the Dryvit finish, the I.S. Base Coat shall have cured a minimum of twenty-four (24) hours and shall be dry and hard. Cure time may be longer depending on environmental conditions.
- B. Inspect the I.S. Base Coat for any irregularities such as trowel marks, board lines, rough corners and edges, improper reinforcing mesh embedment as well as efflorescence. **NOTE: Correct all irregularities and remove all efflorescence prior to applying the Dryvit finish.**
- C. General
 1. **Important:** All Dryvit finishes must be installed continuously to a natural break such as corners, expansion joints, or tapeline. Mechanics must maintain a wet edge. Whenever possible, order enough material in a single batch to complete the project to avoid potential color variations from batch to batch. Sufficient personnel and scaffolding must be provided to continuously finish a distinct wall area or otherwise cold joints will result. Scaffolding must be spaced a minimum of 18 in (457 mm) from the wall to prevent staging lines. On hot windy days, the wall may be fogged with clean potable water to cool the wall and facilitate finish installation. As with other plaster materials, installation work should precede the sun. For example, work the shady or cool side of the building. If this is not possible, scaffold should be shaded with a tarp or nursery shade cloth. Do not introduce water to the finish material once it is installed on the wall. This will cause color variations. Each mechanic must use the same tool and hand motion and match the texture of the mechanics above, below and on each side. Use finish from a single batch number whenever possible to avoid color match problems. If a different batch must be used, try to use on a different elevation.
 2. Do not apply Dryvit materials in the rain. The I.S. Base Coat must be dry prior to applying the Dryvit finish or coatings.
 3. Do not apply textured Dryvit finish material in sealant joints. Refer to Section XI for proper preparation of the Infinity System at sealant joints.
- D. Application
 1. Mix the Dryvit finishes as described in Section III.F.
 2. Infitex QP
 - a. Using a clean stainless steel trowel, apply a coat of the finish in a uniform thickness on the dry base coat. **NOTE: The Dryvit Infitex QP finish shall be applied and leveled to a uniform thickness no greater than the largest aggregate.**

- b. The texture is achieved by uniform hand motion and/or tool that produces the texture to match the approved sample. Each mechanic must use the same tool and hand motion to ensure that the texture achieved is uniform over the entire wall area.
3. Infinitex SP and Infinitex SPF
 - a. Using a clean, stainless steel trowel, apply an even coat of the finish to a thickness slightly thicker than the largest aggregate size.
 - b. Pull across using a horizontal trowel motion to develop a uniform thickness no greater than the largest aggregate of the material.
 - c. The texture is achieved by a uniform hand floating motion with a clean stainless steel trowel; wipe the trowel and wet it lightly. Apply light pressure in a circular motion.
4. Infinitex ADB
 - a. Using a brush, roller or airless spray equipment, apply a coat of color coordinated Color Prime (see Section III.E for mixing instructions) at the recommended coverage to the cured base coat and allow to dry.
 - b. Using a stainless steel trowel, apply a coat of finish approximately 1/16 in (1.6 mm) to the wall surface. Allow the Infinitex ADB finish to take-up.
 - c. Using a stainless steel trowel, apply a second coat of the Infinitex ADB finish to obtain the desired texture.
Tip: An atomizing spray bottle may be used to apply a mist of water to the surface in the finishing step.
5. Specialty Finishes: Ameristone, [DS142](#); Stone Mist, [DS420](#); TerraNeo, [DS481](#); Limestone, [DS472](#); Custom Brick, [DS154](#); Reflectit, [DS124](#); Finesse, [DS859](#); NewBrick, [DS871](#).
 - a. Mix the Specialty finishes as described in Section III.G
 - b. Apply the specialty finishes in accordance with the products' Application Instructions or Data Sheets listed above.

XIV. Coatings and Sealers

NOTE: Coatings and Sealers are not intended to be applied directly over base coat; they are intended to be applied over Dryvit finishes.

- A. Mix coatings and sealers to a smooth homogeneous consistency in accordance with Section III.H.1.
- B. Demandit Smooth and Weathercoat
 1. Apply with a brush, roller, or airless spray equipment.
 2. When applying with a roller, a maximum 3/4 in (19 mm) nap, polyester or polyester blend with nylon or lambswool, with beveled ends and a phenolic core is recommended. An 18 in (458 mm) wide roller frame with a 2 1/4 in (57 mm) inside diameter is also recommended.
 3. Apply in one continuous coat, maintaining a wet edge as the application proceeds to a natural break. The roller cover must be kept fully loaded as the application proceeds. **CAUTION: Do not stretch out the application by rolling with a dry roller. The last leveling roller strokes should always be in the same direction. Do not cut in around openings prior to overall application, but rather, do the cut-in work as the application proceeds.**
 4. Do not allow Demandit Smooth or Weathercoat to dry on roller covers. Roller covers with dried coating do not apply the coating evenly.
 5. Changing color requires the application of two coats.
- C. Demandit Sanded
 1. Apply the Demandit Sanded with a brush or 1/2 in - 5/8 in (12.7 mm – 15.9 mm) nap roller.
 2. Roll or brush in multiple directions and then lightly finish in one direction to ensure that no lap marks remain.
 3. A second coat may be required for heavy textured surfaces or when there is a contrast of colors. Apply the second coat as described in paragraph XIII.B.2 and 3 above. **CAUTION: Do not attempt to apply Demandit Sanded in one heavy coat. Two coats are recommended. Apply the second coat only after the first coat is completely dry. Important: Texture changes will exist after Demandit Sanded is applied over existing Dryvit finishes. The degree of change is a function of the thickness and the number of coats of Demandit Sanded.**

D. Weatherlastic Smooth

1. Mix the Weatherlastic Smooth to a smooth, homogeneous consistency in accordance with Section III.H.1.
2. Apply a minimum 11 mils dry film thickness (22 mils wet film thickness). This is achieved by applying the Weatherlastic Smooth in two (2) 11 mil wet coats. Under average drying conditions, 70 °F (21 °C), 50% RH, two (2) hours drying time between coats should be adequate.
3. For cutting-in and trim, a nylon bristle brush is recommended.
4. Roller Application
 - a. A minimum 10 in (254 mm) roller cover with a 1 1/4 in - 1 1/2 in (32 mm - 38 mm) nap is recommended.
 - b. Completely saturate the roller cover and keep the roller loaded with coating to avoid foaming. Do not dry-roll or over-roll as this will cause excessive entrapment of air within the coating.
 - c. A second coat is applied in a similar manner after the first coat has adequately dried.
5. Spray Application
 - a. Application by airless spray equipment or mastic pump and gun allows application of coating at total required application rate with a minimum of stipple or thickness variations.
 - b. Equipment should have the capacity to pump 2 gal (7.6 L) of coating per minute.
 - c. Material hose should be minimum 1/2 in (12.7 mm) inside diameter for spraying coating through more than a 50 ft (15 m) length. Minimum bursting of 800 lbs (3600 N) is recommended. **Tip: Orifice sizes of 0.021 in - 0.032 in (0.53 mm - 0.81 mm) will be required depending on equipment used.**
 - d. Cross apply coating holding spray gun perpendicular to, and approximately 3 ft (1 m) from the wall surface. Avoid excessive material build-up by holding spray gun away from the wall when pulling the trigger, then bringing gun across area to be coated. Maintain a wet edge and avoid starting and stopping in the middle of the wall. Do not attempt to overreach spray pattern as this may result in appearance of irregular spray pattern. Place scaffolding and equipment to facilitate quick application without numerous interruptions.
 - e. A 10 % loss from overspray should be anticipated.
 - f. Backrolling sprayed areas is recommended to control pinholing on spray applications over porous surfaces.

E. Tuscan Glaze

1. Mix Tuscan Glaze to a smooth homogenous consistency in accordance with Section III.H.2. Continuously agitate throughout application to ensure color consistency.
2. Tuscan Glaze is best applied on large areas using a Hudson-type sprayer or airless spray equipment. For smaller areas, Tuscan Glaze is best applied with a paint pad or, depending on the desired results, a roller, paint brush or sponge. Job site mock-ups are required and should represent the actual job site application techniques.
3. Apply Tuscan Glaze evenly in light strokes. If sagging or running occurs, use a sponge or paint pad to correct immediately. Watch for brush or roller lines. If brush or roller lines appear, use a damp sponge, a paint pad or rag to make them disappear before the Tuscan Glaze starts to dry. The wall may be blotted with a camelback sponge to achieve the desired mottled appearance. Check walls throughout the application to insure that uniformity and the desired appearance is achieved.

F. SealClear

1. Mix SealClear to a smooth, homogeneous consistency in accordance with Section III.H.3.
2. For application instructions, refer to the SealClear Data Sheet, [DS426](#).

XV. Maintenance and Repair

- A. Refer to DryvitCARE EIFS Repair Procedures, [DS498](#).

DISCLAIMER

Information contained in this document conforms to standard detail and product recommendations for the installation of the Dryvit Infinity System products as of the date of publication of this document and is presented in good faith. Dryvit Systems, Inc. assumes no liability, expressed or implied, as to the architecture, engineering or workmanship of any project. To insure that you are using the latest, most complete information, contact Dryvit Systems, Inc., at:

One Energy Way
West Warwick, RI 02893
(401) 822-4100