

DuPont Performance Building Solutions



DuPont™ Tyvek® Mechanically-Fastened Water-Resistive and Air Barrier (WRB) and DuPont Self-Adhered Flashing Products Installation Guidelines



For Commercial and High-Performance Buildings of Any Height

July 2022



Table of Contents

Introduction.....	3
Applicable Products.....	3
Required Materials Based on Project Requirements, Details, and Specifications.....	3
Warranty.....	4
Applicable Structures and Performance Criteria.....	4
Water-Resistive Barrier (WRB) Code Requirements.....	6
Flashing Products Code Requirements.....	6
Additional Codes and Standards Information for DuPont™ Tyvek® Commercial Air and Water Barrier Systems.....	6
Special Considerations.....	7
DuPont™ Tyvek® WRB Installation Instructions (Windows/Doors Installed AFTER the Tyvek® WRB)	9
Key Installation Requirements for DuPont™ Tyvek® Water-Resistive and Air Barriers (WRBs).....	9
Installation Method for New Construction.....	10
Continuity.....	11
Bottom of Wall.....	12
Shelf Angles.....	13
Horizontal Plane Transition.....	13
Installation of Metal Flashing at Façade Transition not at Floorline.....	14
Hybrid Wall – Transition to DuPont™ Tyvek® Fluid Applied Products.....	15
Concrete Cantilevers or Balconies.....	16
Concrete Column.....	17
Parapet Wall with Brick.....	18
Top of Wall Termination at Inside Corner when using Method 2 of the Parapet Wall with Brick.....	19
Top of Wall – Outside Corner when using Method 2 of the Parapet Wall with Brick.....	20
Inside Corner Transition to Concrete.....	22
Penetrations.....	23
Recommended Fasteners and Spacing.....	26
Temporary Fastening.....	26
Alternate Fastening.....	27
Handling Tears and Holes.....	27

Installation Methods for DuPont Self-Adhered Flashing Products Installed AFTER the DuPont™ Tyvek® WRB	28
Key Installation Requirements for Drainable Window / Door Installation.....	28
Non-Flanged Windows and Doors (Using “Wrap the Cavity” Method).....	29
Non-Flanged Window with Floating Lintel and Brick Façade.....	37
Non-Flanged Door on Slab.....	49
Storefront Window on Slab.....	57
Storefront Window on Knee Wall.....	64
Integral Flanged Window.....	72
Integral Flanged Window with DuPont™ FlexWrap™ along the Rough Opening Head.....	80
Alternate Integral Flanged Window Detail Aligned with FMA/AAMA 100-12 (Method A).....	88
Alternate Integral Flanged Window Detail Aligned with FMA/AAMA 100-12 (Method B).....	94
Alternate Integral Flanged Window Detail Aligned with FMA/AAMA 100-12 (Method C).....	100
Drip Cap Installation for Windows and Doors.....	106
Brick Mold Window.....	111
Non-Flanged Window Using DuPont™ VersaFlange™	119
Packaged Terminal Air Conditioner (PTAC) Unit (Using “Wrap the Cavity” Method).....	128
Packaged Terminal Air Conditioner (PTAC) Unit (Using DuPont™ VersaFlange™).....	143
Installation Methods for DuPont Self-Adhered Flashing Products and DuPont™ Tyvek® Fluid Applied Products Installed AFTER the DuPont™ Tyvek® WRB	157
Hybrid Condition — DuPont™ Tyvek® WRB Terminated with DuPont™ StraightFlash™ and/or DuPont™ FlexWrap™ and Integrated with DuPont™ Tyvek® Fluid Applied Products	157
Installation Method for Installing DuPont Self-Adhered Flashing Products BEFORE DuPont™ Tyvek® WRB	161
Non-Flanged or Integral Flanged Window.....	161
Façade/Exterior Considerations.....	164
Product Composition and UV Stability.....	166
Design Considerations.....	166
Safety and Handling.....	166
Hazard Statement.....	167
For More Information.....	167

Introduction

This installation guideline outlines recommended installation techniques and details for **DuPont™ Tyvek® CommercialWrap®** and/or **DuPont™ Tyvek® CommercialWrap® D**, referred to in this document as DuPont™ Tyvek® Water-Resistive and Air Barriers (WRBs) and where applicable, **DuPont Self-Adhered Flashing Products** and **DuPont™ Tyvek® Fluid Applied Products**. Both **Tyvek® WRBs** and **Tyvek® Fluid Applied Products** meet the requirements of a water-resistive barrier as defined in the 2021 International Building Code (IBC). **Tyvek® CommercialWrap®, Tyvek® CommercialWrap® D, and Tyvek® Fluid Applied Products** also function as a high performance air barrier and pass ASTM E2357.

Always check building.dupont.com for the latest versions of DuPont Installation Guidelines and other product literature.

Applicable Products

Mechanically-Fastened Water-Resistive and Air Barriers (Tyvek® WRBs)

Product	Dimensions	Area
DuPont™ Tyvek® CommercialWrap®	5 ft x 200 ft 10 ft x 125 ft	1,000 ft ² 1,250 ft ²
DuPont™ Tyvek® CommercialWrap® D	5 ft x 200 ft 10 ft x 125 ft	1,000 ft ² 1,250 ft ²

Self-Adhered Flashing Products

Product	Width
DuPont™ FlexWrap™	6 in 9 in
DuPont™ FlexWrap™ EZ	2.75 in
DuPont™ StraightFlash™	4 in 9 in
DuPont™ VersaFlange™	6 in
DuPont™ Flashing Tape	4 in 6 in 9 in 12 in

Fluid Applied Products

Product	Quantity
DuPont™ Tyvek® Fluid Applied WB+™	5 gal, 50 gal
DuPont™ Tyvek® Fluid Applied Flashing and Joint Compound+	28 oz, 3.5 gal
DuPont™ Sealant for Tyvek® Fluid Applied System ¹	28 oz

¹DuPont™ Sealant for Tyvek® Fluid Applied System should only be used as directed in the applicable *DuPont™ Tyvek® Fluid Applied Products Installation Guidelines*.

Installation Accessories

Product	Type	Quantity
DuPont™ Tyvek® Tape	3 in Bulk Pack	24 rolls/case
DuPont™ Tyvek® Wrap Cap Screws	2 in dia. plastic cap, 1-3/4 in screw length	1,000 caps/box
Great Stuff Pro™ Window & Door Polyurethane Foam Sealant	Can (reusable dispensing gun sold separately)	20 oz
Great Stuff Pro™ Gaps & Cracks Polyurethane Foam Sealant	Can (reusable dispensing gun sold separately)	20 oz
TRUFAST® Walls Grip-Deck® screws with Thermal-Grip FastCap™ washers (TRUFAST® Walls formerly Rodenhouse)		

Required Materials Based on Project Requirements, Details, and Specifications²

- Backer Rod
- Sealant³
- Adhesive/Primer³
- Brushes for Surface Preparation
- J-Roller
- Trowels
- Wet Mil Gauge

¹DuPont™ Sealant for Tyvek® Fluid Applied System should only be used as directed in the applicable *DuPont™ Tyvek® Fluid Applied Products Installation Guidelines*.

²Apply per manufacturers' guidelines. **For non DuPont products, DuPont assumes no liability in use of recommended products** — installers need to evaluate suitability of recommended products in their end-use applications.

³For information regarding chemical compatibility of these products, see technical bulletin [Chemical Compatibility of Representative Building Sealants and Adhesives/Primers](#).

Warranty

Please refer to [DuPont Building Envelope Solutions Products 10-Year Limited Warranty for Commercial and High-Performance Buildings of Any Height](#).

NOTE: In order to make a claim under the DuPont 10-Year Limited Product and Labor Warranty on DuPont Building Envelope Solutions Products, all terms and conditions of the warranty must be met, including use of the applicable DuPont Installation Guidelines available at the date of original installation. In the event that a specific detail or installation technique is not covered in the DuPont Installation Guidelines at the time of construction, then the [Key Installation Requirements for Drainable Window / Door Installation](#) must have been followed in order to make a claim under the warranty. Compliance prior, during and post construction with the [Key Installation Requirements for Drainable Window / Door Installation](#) are at the sole discretion of DuPont. Please contact DuPont or a DuPont Representative if you have any questions in connection with any DuPont Installation Guideline.

Applicable Structures and Performance Criteria

Applicable Structures

These Installation Guidelines are for Commercial and High-Performance Buildings of Any Height as defined below.

DuPont categorizes structures into three primary groups:

- i.) **“Single-Family Residential Buildings”** are defined as fully-detached one or two family structures, as well as townhouse structures not more than three stories above grade plane as defined in the 2018 International Residential Code (IRC) Section R101.2, both to the extent they are exclusively Residential Use building structures.
- ii.) **“Wood-Framed Multi-Family and Light Commercial Buildings”** are defined as the following (must meet **ALL** criteria):
 - a. Constructed of wood-based structural exterior framing of Type III or Type V Construction* (IBC Chapter 6); and
 - b. Does not exceed 2021 IBC max height (Table 504.3) for Type V construction (70 ft.) or Type III construction (85 ft.), including allowances for Automatic Sprinkler height increase (IBC 504.1 and Table 504.4) and ‘podium’ structures outlined in the Special Provisions* (IBC Section 510); and
 - c. Design requirements for the building envelope do not exceed air barrier performance of ASTM E1677 (10.8 psf structural load, 65 mph equivalent wind load), and water infiltration resistance criteria of 6.24 psf (50 mph equivalent wind-driven rain) when tested in accordance with ASTM E331, ASTM E1105, or equivalent.

*Special Provisions (IBC Section 510) allows for a “horizontal building separation”, or ‘podium’, to be built under the wood-framed Type III or Type V building. The podium is typically constructed of steel framing or concrete. Podium-style buildings are included under “Wood-Framed Multi-Family and Light Commercial Buildings”, as long as all other definition criteria (a. through c. above) are met.
- iii.) **“Commercial and High-Performance Buildings of Any Height”** can be defined as any of the following:
 - a. Structures constructed of steel-based structural exterior framing and any exterior sheathing, or
 - b. Structures with exterior above grade walls constructed of concrete or concrete masonry units (CMU), or
 - c. Structures of any height and construction type (including any framing type) that are designated as high-performance. “High-performance” is defined as air barrier performance exceeding ASTM E1677 and/or water infiltration resistance criteria exceeding 6.24 psf when tested in accordance with ASTM E331, ASTM E1105, or equivalent.

NOTE: “Podium” style structures with wood-framed floors built above steel-framed or concrete/CMU floors are covered under “Wood-Framed Multi-Family and Light Commercial Buildings” unless they are “high-performance”.

Applicable Structures and Performance Criteria

Water-Resistive Barrier Performance Requirements

Buildings with high-performance air barrier designs are defined by DuPont as those with air barrier performance equivalent to ASTM E2357 (or other exceeding ASTM E1677), and/or water infiltration resistance criteria greater than 6.24 psf when tested in

accordance with ASTM E331, ASTM E1105, or equivalent. Installation of DuPont Building Envelope Solutions Products on high-performance buildings requires the use of this guide and [DuPont™ Tyvek® Fluid Applied WB+™ Wall and Substrate Guidelines](#) and/or the [DuPont™ Tyvek® Fluid Applied Flashing Installation Guidelines](#).

These Installation Guidelines should be used for buildings which meet the applicable structures definitions and performance criteria on the previous page. The following table provides a summary of typical installation information.

DuPont Building Envelope Solutions Products Installation Considerations for Commercial and High-Performance Buildings of Any Height	
Performance Criteria	Buildings with high-performance air barrier designs are defined by DuPont as those with air barrier performance equivalent to ASTM E2357 (or other exceeding ASTM E1677), and/or water infiltration resistance criteria greater than 6.24 psf when tested in accordance with ASTM E331, ASTM E1105, or equivalent.
DuPont™ Tyvek® WRB¹	DuPont™ Tyvek® CommercialWrap® or Tyvek® CommercialWrap® D (required on the entire building)
DuPont™ Tyvek® Tape	3" Tyvek® Tape required along all Tyvek® WRB seams
DuPont™ Tyvek® Fluid Applied Products	Can be used on any above grade exterior wall where specified in hybrid details in this guide. Recommended for use on above grade exterior CMU and/or concrete walls. Refer to the Installation Guidelines for DuPont™ Tyvek® Fluid Applied Flashing and/or Tyvek® Fluid Applied WB+™ for additional information
Typical Recommended Fasteners and Spacing²	2" DuPont™ Tyvek® Wrap Cap Screws or approved TRUFAST® Walls Fasteners (formerly Rodenhouse)
Air Barrier Details	Required when the designated building envelope performance requirements are equivalent to and/or exceed ASTM E1677 (65 mph equivalent structural load and 15 mph equivalent wind-driven rain water infiltration resistance).
Tyvek® WRB Terminations to Sheathing	DuPont Self-Adhered Flashing Products
Recommended Window/Door Head Flap Treatment	DuPont Self-Adhered Flashing Products with additional mechanical fasteners through the flashing offers a more robust termination than DuPont™ Tyvek® Tape .
Self-Adhered Flashing Patches behind Cladding Fasteners	Required when water infiltration resistance criteria for the building envelope exceeds 0.56 psf (15 mph equivalent wind-driven rain), nominal test pressure per ASTM E1677. See the Alternate Fastening section in this document for more information.

¹ Buildings requiring NFPA 285 compliance must use **Tyvek® CommercialWrap®** or **Tyvek® CommercialWrap® D** in accordance with [DuPont NFPA 285 documentation](#).

² For increased holding power and for higher air and water holdout performance, DuPont recommends fasteners of sufficient length to penetrate securely into the stud.

Water-Resistive Barrier (WRB) Code Requirements

The 2021 International Building Code (Section 1402.2 Weather Protection) requires that “exterior walls shall provide the building with a weather-resistant exterior wall envelope. The exterior wall envelope shall be designed and constructed in such a manner as to prevent the accumulation of water within the wall assembly by providing a water-resistive barrier behind the exterior veneer, as described in Section 1403.2, and a means for draining water that enters the assembly to the exterior. The exterior wall envelope shall include flashing, as described in Section 1404.4. Section 1403.2 (Water-resistive barrier) states that “not fewer than one layer of water-resistive barrier material shall be attached to the studs or sheathing, with flashing as described in Section 1404.4 in such a manner as to provide a continuous water-resistive barrier behind the exterior veneer.”

The **DuPont™ Tyvek® WRBs** listed below qualify as approved water-resistive barriers based on ICC-ES AC38 Acceptance Criteria according to the associated Evaluation Reports:

- ICC-ES Evaluation Report ESR 2375
 - **DuPont™ Tyvek® CommercialWrap®**
 - **DuPont™ Tyvek® CommercialWrap® D**

DuPont™ Tyvek® Fluid Applied WB+™ meets ICC-ES AC212, Acceptance Criteria for Water-Resistive Coatings Used as Water-Resistive Barriers Over Exterior Sheathing, per the following:

- Intertek Code Report: CCRR-0307 for **Tyvek® Fluid Applied WB+™**

Air leakage control and air barriers are required in the IECC-2018 Sections R402.4 and C402.5. Specifically, Section C402.5 identifies three compliance options for air barriers.

Tyvek® WRBs comply with the option detailed in Section C402.5.1.2.1 Materials:

“Materials with an air permeability no greater than 0.004 cfm/ft² (0.02 L/s x m²) under a pressure differential of 0.3 inches water gauge (75 Pa) when tested in accordance with ASTM E2178 shall comply with this section.” **Tyvek® WRBs** have been tested in accordance with ASTM E2178 and have air permeability less than 0.004 cfm/ft² (0.02 L/s x m²).

Flashing Products Code Requirements

The 2021 International Building Code (Section 1404.4 Flashing) requires that “flashing shall be installed in such a manner so as to prevent moisture from entering the wall or to redirect that moisture to the surface of the exterior wall, wall finish, or to a water-resistive barrier complying with Section 1403.2 and that is part of a means of drainage complying with Section 1402.2. Flashing shall be installed at the perimeters of exterior door and window assemblies, penetrations and terminations of exterior wall assemblies, exterior wall intersections with roofs, chimneys, porches, decks, balconies and similar projections and at built-in gutters and similar locations where moisture could enter the wall. Flashing with projecting flanges shall be installed on both sides and the ends of copings, under sills and continuously above projecting trim. Where self-adhered membranes are used as flashings of fenestration in wall assemblies, those self-adhered flashings shall comply with **AAMA 711**. Where fluid applied membranes are used as flashing for exterior wall openings, those fluid applied membrane flashings shall comply with **AAMA 714**.”

- **DuPont Self-Adhered Flashing Products** comply with **AAMA 711** (an FGIA Specification) *Specification for Self Adhering Flashing Used for Installation of Exterior Wall Fenestration Products*.
- **DuPont™ Tyvek® Fluid Applied Flashing and Joint Compound+** complies with **AAMA 714**, *Voluntary Specification for Liquid Applied Flashing Used to Create a Water-Resistive Seal around Exterior Wall*.

Additional Codes and Standards Information for DuPont™ Tyvek® Commercial Air and Water Barrier Systems

Tyvek® CommercialWrap®, Tyvek® CommercialWrap® D, DuPont™ FlexWrap™, DuPont™ StraightFlash™, and DuPont™ Tyvek® Fluid Applied Products were designed for the rigors of heavy commercial construction. These commercial products have been tested to the following standards:

- ABAA Evaluated
- ASTM E2357 *Standard Test Method for Determining Air Leakage of Air Barrier Assemblies*
- ASTM E331 *Standard Test Method for Water Penetration of Exterior Windows, Skylights, Doors, and Curtain Walls by Uniform Static Pressure*
- ASTM E1105 *Standard Test Method for Field Determination of Water Penetration of Installed Exterior Windows, Skylights, Door, and Curtain Walls, by Uniform or Cyclic Static Air Pressure Difference*
- ASTM E283 *Standard Test Method for Determining Rate of Air Leakage Through Exterior Windows, Curtain Walls and Doors Under Specified Pressure Differences Across the Specimen*
- AAMA 501.5 *Test Method for Thermal Cycling of Exterior Walls*
- ASTM E2273 *Standard Test Method for Determining the Drainage Efficiency of Exterior Insulation and Finish Systems (EIFS) Clad Wall Assemblies (excludes Tyvek® Fluid Applied WB+™)*.
- NFPA 285 *Standard Fire Test Method for Evaluation of Fire Propagation Characteristics of Exterior Non-Load-Bearing Wall Assemblies Containing Combustible Components*

Energy Conservation Codes for commercial buildings are being adopted in many regions across the U.S. **Tyvek® WRBs** currently meet the following codes and guidelines.

- ASHRAE 90.1 Model Energy Code air barrier requirements
- 2018 International Energy Conservation Code® (IECC)
- 2018 International Green Construction Code™ (IgCC)

Special Considerations

1. In general, these Installation Guidelines, including the allowable use of DuPont Products, are based on **air barrier performance exceeding ASTM E1677 and/or water infiltration resistance criteria exceeding 6.24 psf**, when tested in accordance with ASTM E331, ASTM E1105, or equivalent.
2. Buildings requiring NFPA 285 compliance must use **DuPont™ Tyvek® CommercialWrap®, Tyvek® CommercialWrap® D**, or **DuPont™ Tyvek® Fluid Applied WB+™** in accordance with DuPont NFPA 285 documentation. See [NFPA 285 Compliant Wall Assemblies](#) with DuPont™ Tyvek® Commercial Air and Water Barrier Systems and building.dupont.com for more information.
3. **Tyvek® CommercialWrap® D must be installed with the grooves going up and down.**
4. **Tyvek® CommercialWrap®** offers >90% drainage efficiency and **Tyvek® CommercialWrap® D** offers >98% drainage efficiency when tested in accordance with ASTM E2273.
5. Building envelope design requirements exceeding 0.56 psf (15 mph equivalent wind-driven rain) water infiltration resistance per ASTM E1677 **require DuPont™ StraightFlash™, DuPont™ Flashing Tape** or recommended alternate patches behind fastening plates (brick tie base plates, metal fastening clips, metal channels, etc.). When used behind the facade fasteners and/or fastening plates, the flashing patch **must be** adhered to the **DuPont™ Tyvek® WRB**.
6. For structures with high performance building envelope designated performance requirements and a stucco exterior facade, **DuPont Self-Adhered Flashing Products** or approved alternate blind seal protection is required at the each metal lath fastener location. When used behind the facade fasteners and/or fastening plates, the flashing patch **must be** adhered to the **Tyvek® WRB**.
7. **DuPont Self-Adhered Flashing Products** should be installed on clean, dry surfaces that are free of frost. Wipe surfaces to remove moisture, dirt, grease and other debris that could interfere with adhesion.
8. **DuPont Self-Adhered Flashing Products** perform best when installed at temperatures above 25°F (-4°C).
9. Adverse weather conditions or cold temperatures may require use of a recommended adhesive/primer to promote adhesion of **DuPont Self-Adhered Flashing Products** to most common building materials. **Concrete, masonry, and fiber-faced exterior gypsum board require the use of a recommended adhesive/primer.** Do not apply an adhesive/primer to exterior continuous insulation due to potential sheathing degradation.
10. Apply pressure along entire surface of flashing for a good bond using firm hand pressure, J-roller, or alternate tool without sharp edges (such as a plastic carpet tuck tool) to assist with application of uniform pressure during installation of **DuPont Self-Adhered Flashing Products**.
11. Remove all wrinkles and bubbles by smoothing surface and repositioning as necessary during installation of **DuPont Self-Adhered Flashing Products**. Apply pressure along entire surface of flashing for a good bond using firm hand pressure, J-roller, or alternate tool without sharp edges (such as a plastic carpet tuck tool) to assist with application of uniform pressure.
12. **DuPont Self-Adhered Flashing Products** are not intended for through-wall flashing applications.
13. When using mechanically-fastened through-wall flashing, DuPont recommends sealing top edge of the through wall with **StraightFlash™** or **DuPont™ Flashing Tape**.
14. When flashing the sill area for windows and doors, DuPont recommends the use of 6" wide **DuPont™ FlexWrap™** for 2" x 4" framing and 9" wide **FlexWrap™** for 2" x 6" framing. When rigid back dams are required or desired, an option would be to use a 3/4" corner guard (back dam) cut to the length of the sill and nail into place on the interior edge of the sill prior to installation of 9" wide **FlexWrap™**. Then install 9" wide **FlexWrap™** over sill and corner guard back dam. A continuous interior perimeter seal must be effectively created, and should be accounted for when a back dam is used.
15. **Do Not Stretch FlexWrap™** when installing along the rough opening (i.e. sill, jambs, and/or head). **FlexWrap™** is only intended to be stretched when covering corners or curved sections.
16. **DuPont Self-Adhered Flashing Products** can be used to bridge non-movement gaps up to 1" unsupported. Flashing must maintain a 2" adhesive lap on the wall substrate.
17. **DuPont™ FlexWrap™ EZ can not be used** in lieu of **FlexWrap™** for any commercial window condition beyond where captured in this guide.
18. When installing the **Tyvek® WRB**, **do not install fasteners within 6" of the sills and jambs of the openings and within 9" of the head of the openings.**
19. Avoid placing **DuPont™ Tyvek® Wrap Cap Fasteners**, or recommended fasteners, where flashing will be installed; however, fasteners can be installed over the flashing.
20. **Do Not Apply DuPont™ Tyvek® Tape** or **DuPont Self-Adhered Flashing Products** over **Tyvek® Wrap Cap Fasteners** or recommended fasteners.
21. **Great Stuff Pro™ Window and Door Polyurethane Foam Sealant** can be used in lieu of sealant to create a continuous seal around the interior perimeter of the window openings. When using **Great Stuff Pro™ Window and Door Polyurethane Foam Sealant** in perimeter openings less than 1/2", apply using the plastic extension tip for the **Great Stuff™ Dispenser Gun** during installation. See window details for additional information pertaining to the creation of the interior perimeter seal.
22. When the **Tyvek® WRB** is installed over exterior insulation the **Tyvek® WRB** should be fastened with TRUFAST® Walls Thermal-Grip FastCap™ fasteners.

Special Considerations

23. When a **DuPont™ Tyvek® WRB** is to be installed under continuous exterior insulation please refer to [DuPont Commercial Wall² System DuPont™ Tyvek® CommercialWrap® or Tyvek® CommercialWrap® D Weather-Resistive Barrier \(WRB\) UNDER DuPont Exterior Continuous Insulation](#) for guidance.
24. When a **Tyvek® WRB** is to be installed over continuous exterior insulation please refer to the DuPont Commercial Wall² System installation bulletin: [DuPont™ Tyvek® CommercialWrap® or Tyvek® CommercialWrap® D Weather-Resistive Barrier \(WRB\) OVER DuPont Exterior Continuous Insulation](#) for guidance.
25. Continuous exterior insulation has little to no (minimal) fastener holding power and should not be used as a nailing base substrate for **Tyvek® WRBs**.
26. For high pressure design loads, the use of **DuPont™ StraightFlash™** with **DuPont™ Tyvek® Wrap Cap Fasteners**, or recommended fasteners, is required to secure the head flap of the windows.
27. In lieu of temporarily taping, **Tyvek® WRB** flaps at window head and jambs can be tucked under the installed **Tyvek® WRB**.
28. 3" **DuPont™ Tyvek® Tape** should not be used to terminate **Tyvek® WRB** flaps at window jambs and head when the building envelope design requirements exceed ASTM E1677, 65 mph equivalent structural load and 15 mph equivalent wind-driven rainwater infiltration resistance. **DuPont Self-Adhered Flashing Products** provide a more robust head flap termination.
29. Door and window rough sill framing must be level or slightly sloped to the exterior to ensure proper drainage to the exterior. This best practice ensures continuous support with positive slope to the exterior.
30. For window or door openings greater than 6 feet wide, **StraightFlash™** can be used with **DuPont™ FlexWrap™** in 3-piece sill/head applications. **StraightFlash™** should be applied the length of the sill prior to placing the **FlexWrap™** corners. The **FlexWrap™** corners should be at least 12" long allowing for 6" up the jamb and 6" of overlap on the **FlexWrap™** sill flashing. When applying the 3-piece flashing detail to the head of the opening, the **StraightFlash™** head piece should be applied prior to installing the **FlexWrap™** corner flashing. Minimum overlapping of the **FlexWrap™** head flashing and jamb flashing should be a minimum of 6". **Registered DuPont Commercial Certified Installers may use the 3-piece sill/head flashing method on window and door openings of any size.**
31. Suitable substrates for **Tyvek® Fluid Applied Products** include concrete masonry unit (CMU), concrete (48 hrs. cure for green concrete), exterior gypsum, OSB, plywood, wood, and metal. Contact your local DuPont™ Tyvek® Specialist for use with pressure treated or fire retardant treated wood (FRT).
32. **Tyvek® Fluid Applied Products** should only be used for wall systems that include a continuous path for drainage allowing moisture that penetrates the facade to exit to the exterior. The drainage path should be continuous throughout the wall assembly, including but not limited to areas such as eyebrows, band boards, penetrations, or other locations where transitions and changes of plane occur. For membrane drainage wall systems, ensure that the drainage path is not blocked or disrupted to prevent excess moisture buildup in the wall cavity.
33. Uncured **Tyvek® Fluid Applied Products** must not come in contact with building wraps due to potential impact on performance properties.
34. **DuPont™ Tyvek® CommercialWrap®** and **Tyvek® CommercialWrap® D** may be installed over **Tyvek® Fluid Applied Products** after 48 hours of curing at 70°F (20°C) and 50% RH.
35. **Tyvek® Fluid Applied Products** can be applied to damp surfaces. A surface is considered damp if there is no visible water on the surface and no transfer of water to the skin when touched.
36. **DuPont™ Tyvek® Fluid Applied Flashing and Joint Compound+** can be troweled or brushed to the required thickness in any application outlined in the guide.
37. **Tyvek® Fluid Applied Products** should be applied when air and surface temperatures are above 25°F. Do not install once the ambient temperature exceeds 95°F (35°C), unless the application surface is shaded. The maximum surface temperature for application is 140°F (60°C).
38. **Tyvek® Fluid Applied Products** may be overcoated once a tack-free skin has formed. Exterior insulation and/or exterior facade may be installed after **Tyvek® Fluid Applied Products** have cured for 48 hours. Please refer to the [Drying/Curing information in the DuPont™ Tyvek® Fluid Applied WB+™ Wall and Substrate Guidelines](#).
39. Performance testing, included but not limited to peel adhesion, pull strength analysis, field or third-party testing of air and/or water barrier properties, should be conducted after **Tyvek® Fluid Applied Products** are fully cured (~14 days).
40. **Tyvek® CommercialWrap®** and **Tyvek® CommercialWrap® D** must not come in direct contact with other manufacturers' cured or uncured fluid-applied and/or deck coating waterproofing products due to potential impact on performance properties. **StraightFlash™** can be used as transitional membrane.
41. DuPont requires **Tyvek® WRBs**, **DuPont Self-Adhered Flashing Products**, and **Tyvek® Fluid Applied Products** be covered within 9 months (270 days) of installation.
42. The maximum in-service temperature for **Tyvek® WRBs**, **DuPont Self-Adhered Flashing Products**, and **Tyvek® Fluid Applied Products** is 180°F.
43. When using the "Wrap-the-Cavity" flashing options for PTAC Units, two (2) pieces of **FlexWrap™** may be used in lieu of typical wrap-the-cavity of **FlexWrap™** and **StraightFlash™** for PTAC Unit openings up to 16" in height.
44. 4" **StraightFlash™** should not be used for the PTAC Unit "Wrap-the-Cavity" flashing options.

DuPont™ Tyvek® WRB Installation Instructions (Windows/Doors Installed AFTER the Tyvek® WRB)

Key Installation Requirements for DuPont™ Tyvek® Water-Resistive and Air Barriers (WRBs)

Continuity

It is important to maintain the continuity of the **Tyvek® WRBs** throughout the building envelope. The entire wall surface shall be wrapped, including unconditioned spaces. Special attention should be given to ensure a proper 6" overlap at all terminations, seams, penetrations, and transitions to maintain a continuous downward drainage plane and water-resistive barrier.

Penetrations

Seal the **Tyvek® WRB** around all penetrations (electrical, HVAC and plumbing, etc.) with the appropriate **DuPont Self-Adhered Flashing Product**. The rough opening can be sealed from the interior side using sealant (and backer rod as necessary), or **Great Stuff Pro™ Window & Door Polyurethane Foam Sealant, Great Stuff Pro™ Gaps & Cracks Polyurethane Foam Sealant**, or recommended foam.

Overlap

Ensure proper shingling with a 6" minimum overlap of water-resistive barrier components from the bottom to the top of the wall to help facilitate proper drainage.

Sealants and Adhesives/Primers

Review the manufacturers' literature or label to confirm that the product(s) used have the chemical and adhesive properties necessary for use with **Tyvek® WRBs, DuPont Self-Adhered Flashing Products**, and **DuPont™ Tyvek® Fluid Applied Products**. Refer to [Chemical Compatibility of Representative Building Sealants and Adhesives/Primers](#) for more information about chemical compatibility.

Fasteners

Use **DuPont™ Tyvek® Wrap Cap Fasteners**, TRUFAST® Walls (formerly Rodenhouse) Grip-Deck® screws with Thermal-Grip FastCap™ washers, or recommended alternates, per the fastening schedule included in this installation guideline. DuPont recommended fasteners should be secured to the framing membrane. It is **not acceptable** for screw fasteners to attach to the exterior sheathing only. Recommended screw cap fasteners that miss the framing member should be removed and the hole repaired with 3" **DuPont™ Tyvek® Tape**.

If DuPont recommended fasteners are installed with a vertical fastening spacing that's greater than what's shown in [Table 1](#) (reducing the quantity of fasteners), they will be considered temporary fasteners. Temporary fasteners should not be relied upon to permanently attach **Tyvek® WRBs**, due to the limited holding power of this fastening method. If temporary fasteners are used, permanent fastening must be applied as

soon as practically possible in order to maintain the integrity and performance of the **Tyvek® WRB** and to be in compliance with DuPont Installation Guidelines if making a claim under the DuPont Product and Labor Warranty. Refer to the [Recommended Fasteners and Spacing and Temporary Fastening](#) sections for more complete fastening information. Examples of recommended fasteners include:

Recommended Fasteners

- 2" **DuPont™ Tyvek® Wrap Cap Screws** (for steel frame construction, may also be used for wood frame)
- 1-1/4" metal gasketed washers with screws (for steel frame construction)
- 2" metal gasketed washers with screws (for steel frame construction)
- Tapcon® fasteners with 2" plastic caps (for masonry construction)
- TRUFAST® Walls Grip-Deck® screws with Thermal-Grip FastCap™ washers installed at 16" vertical spacing along stud lines for 16" o.c. framing (approved for use with **Tyvek® WRBs**).

Metal frame construction:

- 1-5/8" – 6" TRUFAST® Walls Grip-Deck® Self-Drilling screws with 2" dia. Thermal-Grip FastCap™ washer.
- 1-5/8", 2", 2-1/2", and 3" screws can be installed with standard hand drill or Grip-Lok® Autofeed Fastening System* with modified nose adaptor.
- 3-1/2" to 6" screws should be installed with standard hand drill
- A minimum of 4 threads screw penetration through the steel stud is required.

Wood frame construction:

- 1-5/8" – 6" TRUFAST® Walls Grip-Deck® HiLo Thread Screws with 2" Thermal-Grip FastCap™ washer
- 1-5/8" screws can be used for structural loading performance requirements per ASTM E2357 and water infiltration resistance up to 9 psf, installed with standard hand drill or Grip-Lok® Autofeed Fastening System* with modified nose adaptor.
- 2" or longer screws must be used for structural loading performance requirements per ASTM E2357 and water infiltration resistance up to 15 psf installed with standard hand drill or Grip-Lok® Autofeed Fastening System* with modified nose adaptor. A minimum 1" of screw penetration into the wood stud is required for assemblies requiring 15 psf water infiltration resistance.
- 3-1/2" to 6" screws should be installed with standard hand drill.

*For more information about the Grip-Lok® Autofeed Fastening System, refer to manufacturer's instructions and contact your local DuPont™ Tyvek® Specialist.

DuPont™ Tyvek® WRB Installation Instructions (Windows/Doors Installed AFTER the Tyvek® WRB)

Installation Method for New Construction

STEP 1

- A. Starting at a corner of the building unroll **DuPont™ Tyvek® WRB** keeping the roll plumb. Extend approximately 12" past either the inside or outside corner of the wall.
- B. Vertically overlap the next sheet of **Tyvek® WRB** by at least 6". Vertical grid lines have been provided every 8" on **DuPont™ Tyvek® CommercialWrap®** to assist in alignment with stud spacing.

NOTES:

- It is important that proper shingling is maintained. **Tyvek® WRBs** should be installed from the bottom of the building up to ensure proper shingling.
- Vertical installation of **Tyvek® CommercialWrap®** is acceptable. 6" overlap and proper shingling of vertical and horizontal seams is required. Vertical installation is not permitted for **DuPont™ Tyvek® CommercialWrap® D**.

STEP 2

Ensure **Tyvek® WRB** overlaps the through wall flashing by a minimum 4"–6".

STEP 3

Secure the **Tyvek® WRB** by fastening into the studs. For fastener type and spacing refer to the [Recommended Fasteners and Spacing](#) section of this document.

NOTE: In order to keep the **Tyvek® WRB** from being damaged by cladding installation, special attention should be taken to ensure that the product is pressed tightly into any inside corners before fastening.

STEP 4

Unroll the **Tyvek® WRB** directly over window and door rough openings. Upper layer of **Tyvek® WRB** should overlap bottom layer of **Tyvek® WRB** by a minimum of 6". Do not install fasteners within 6" of the sills and jambs of the openings and within 9" of the head of the openings. The **Tyvek® WRB** will be secured at these locations during flashing installation.

STEP 5

Tape all horizontal and vertical seams of the **Tyvek® WRB** with 3" **DuPont™ Tyvek® Tape**.

STEP 6

Terminate the **Tyvek® WRB** at the bottom of the wall with **DuPont™ StraightFlash™** or 3" **Tyvek® Tape**.

NOTE: If 3" **Tyvek® Tape** is going to be used to terminate the **Tyvek® WRB** along the base of wall, it should be installed prior to tapping the vertical **Tyvek® WRB** seams. **StraightFlash™** offers the more robust termination.

STEP 7

After the **Tyvek® WRB** is installed, refer to the [Installation Methods for DuPont Self-Adhered Flashing Products Installed AFTER the DuPont™ Tyvek® WRB](#) section in this guide to prepare and flash windows and doors.

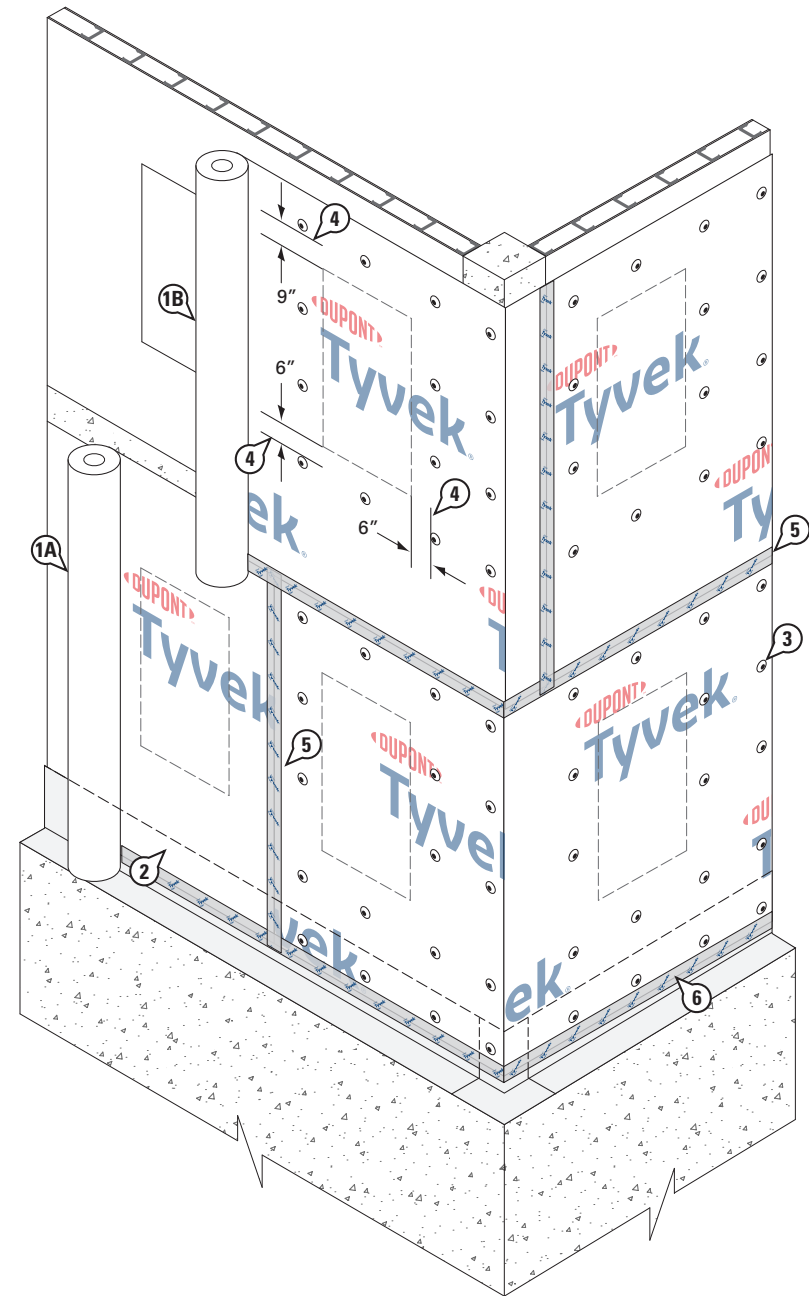

DuPont™ Tyvek® WRB Installation Instructions (Windows/Doors Installed AFTER the Tyvek® WRB)

Continuity

It is important to maintain the continuity of the DuPont™ Tyvek® WRB from top to bottom with proper shingling and overlap. The entire wall surface shall be wrapped, including unconditioned spaces.

Special attention should be given to all terminations and transitions to ensure a proper drainage plane and a continuous air and water barrier is maintained. This guide includes details for top of wall, concrete columns, and other key transitions.

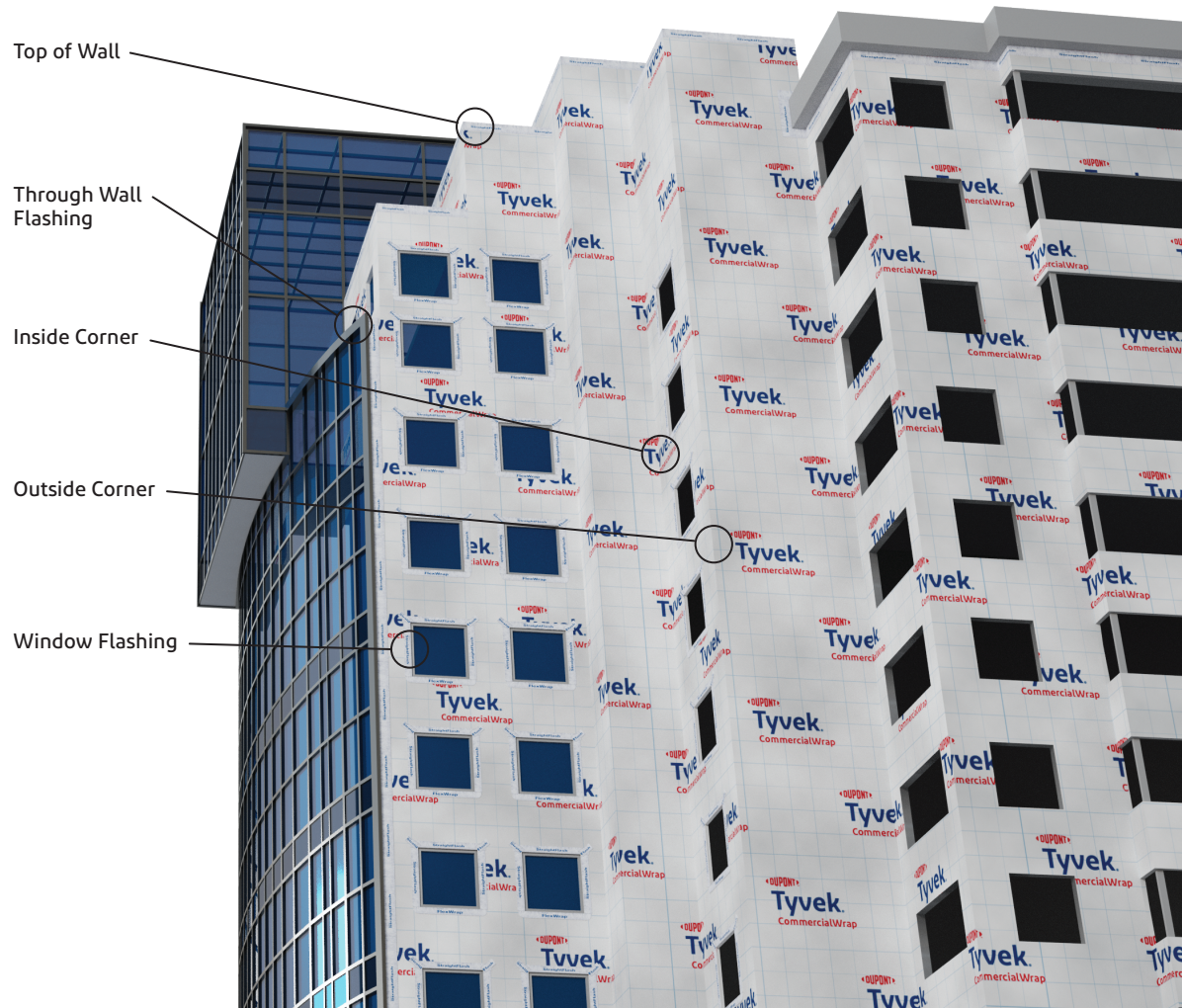

DuPont™ Tyvek® WRB Installation Instructions (Windows/Doors Installed AFTER the Tyvek® WRB)

Continuity

Bottom of Wall

Method 1

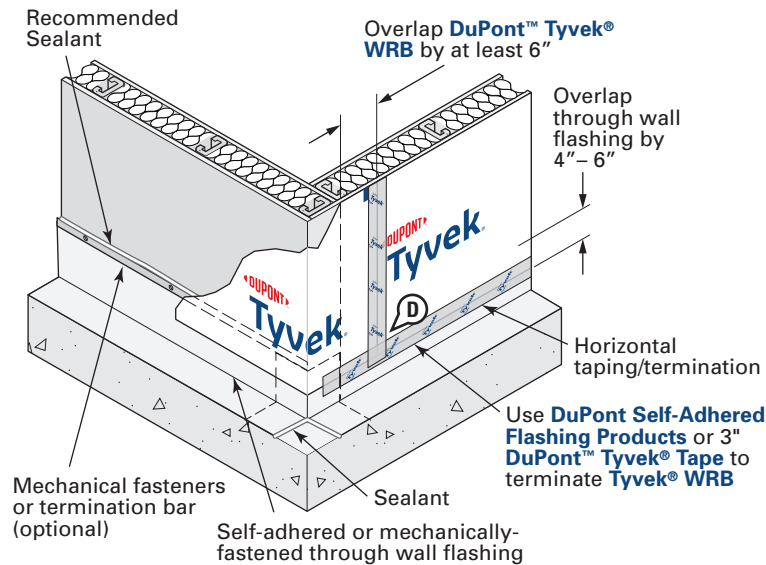

- A. Install through wall flashing per manufacturer's instructions and/or architectural plans. The through wall flashing may be terminated by using a reglet, counterflashing, or termination bar.
- B. Apply chemically compatible recommended sealant along the top of the through wall and/or termination bar. **NOTE:** Sealant should be allowed to cure prior to the Tyvek® WRB overlap and termination.
- C. Overlap through wall flashing with Tyvek® WRB by 4"– 6" (recommended min).
- D. Seal vertical and horizontal seams using 3" DuPont™ Tyvek® Tape.
- E. Terminate Tyvek® WRB with DuPont Self-Adhered Flashing Products or 3" Tyvek® Tape. **NOTE:** DuPont™ StraightFlash™ provides the most robust termination for the Tyvek® WRB.

Method 2

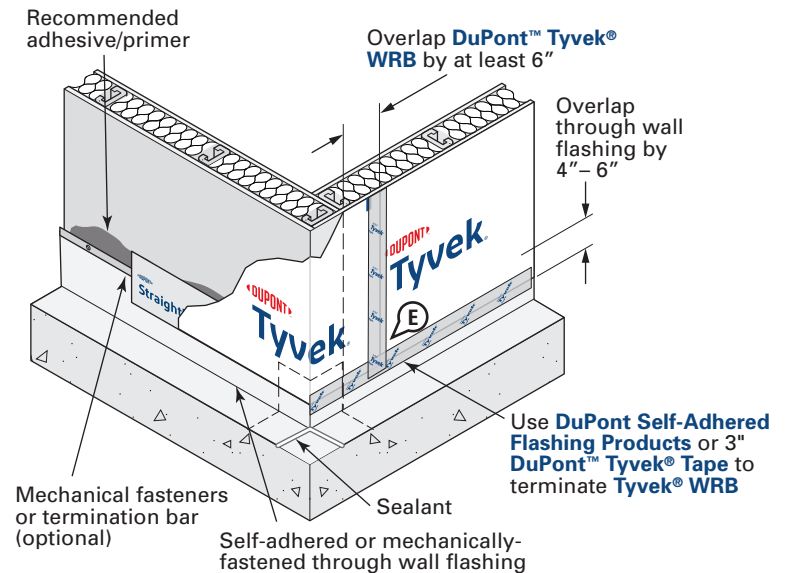

- A. Install through wall flashing per manufacturer's instructions and/or architectural plans. The through wall flashing may be terminated by using a reglet, counterflashing, or termination bar.
- B. Apply recommended adhesive/primer to exterior sheathing where DuPont Self-Adhered Flashing Products would be installed.
- C. Apply StraightFlash™ along the top edge of the through wall flashing
- D. Overlap through wall flashing with Tyvek® WRB by 4"– 6" (recommended min).
- E. Seal vertical and horizontal seams using 3" Tyvek® Tape
- F. Terminate Tyvek® WRB with DuPont Self-Adhered Flashing Products or 3" Tyvek® Tape.

NOTE: StraightFlash™ provides the most robust termination for the Tyvek® WRB.

DuPont™ Tyvek® WRB Installation Instructions (Windows/Doors Installed AFTER the Tyvek® WRB)

Continuity

Shelf Angles

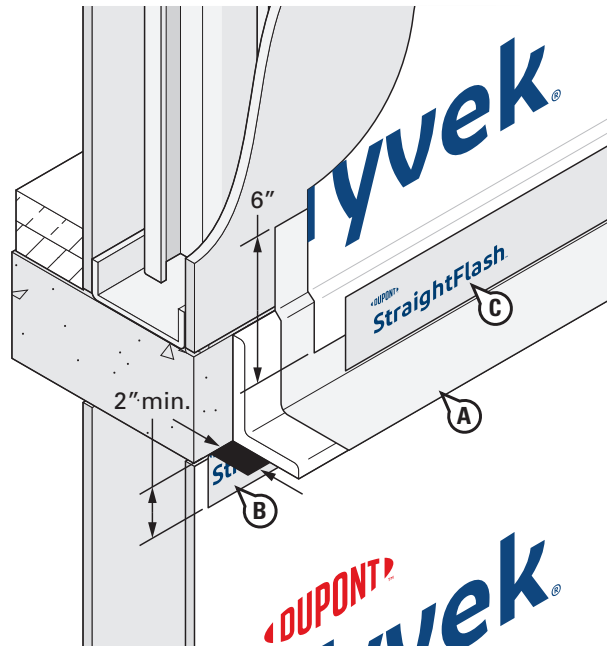

- A. Self-adhered through wall flashing should be applied to the top of the shelf angle and the **DuPont™ Tyvek® WRB** should be properly shingled over by at least 6”.
- B. Terminate **Tyvek® WRB** along the vertical wall substrate under the shelf angle using **DuPont™ StraightFlash™**. **StraightFlash™** should be installed with 2” min to the **Tyvek® WRB** and 2” min to the shelf angle.
- C. Terminate bottom of the **Tyvek® WRB** to through wall flashing using **StraightFlash™**.

Horizontal Plane Transition

Detail isolates horizontal plane from vertical walls for water management

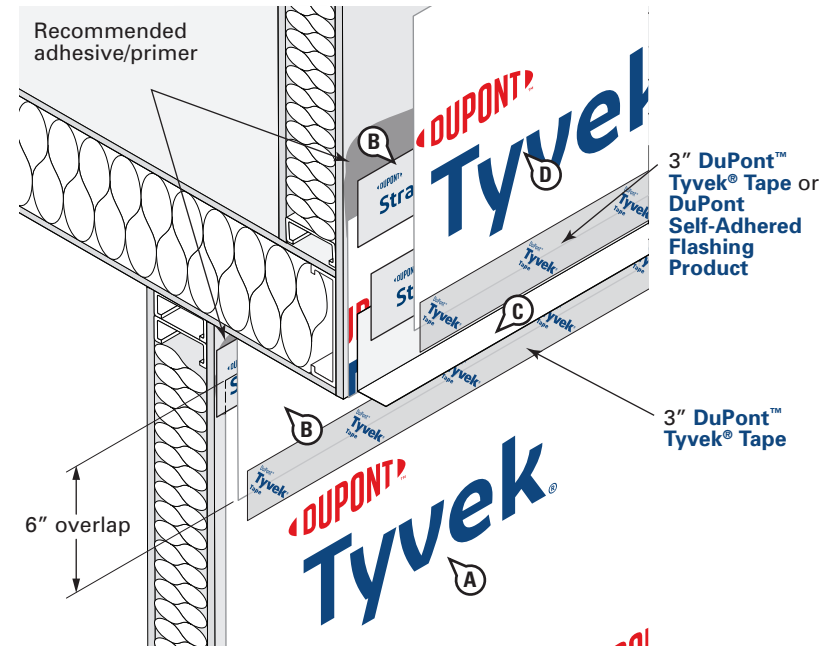

- A. Install **Tyvek® WRB** on wall below horizontal plane and terminate with **StraightFlash™**. Prime sheathing as necessary with a recommended adhesive/primer.
- B. Install **Tyvek® WRB** on horizontal plane, overlapping the **Tyvek® WRB** below by 6”, and extend a minimum of 6” onto the vertical wall above. Install 3” **Tyvek® Tape** to seal horizontal seam below and terminate onto upper wall with **StraightFlash™**. Prime sheathing as necessary with a recommended adhesive/primer.
- C. **Optional:** Install a kick-out flashing at outside corner as recommended best practice per plans and specifications. Terminate vertical leg of kick-out flashing with **StraightFlash™**.
- D. Install **Tyvek® WRB** on wall above horizontal plane and terminate onto kick-out flashing with **StraightFlash™** or **Tyvek® Tape**. **NOTE:** If kick-out flashing is not used, ensure a 6” overlap and seal the horizontal **Tyvek® WRB** seam with 3” **Tyvek® Tape**.

DuPont™ Tyvek® WRB Installation Instructions (Windows/Doors Installed AFTER the Tyvek® WRB)

Continuity

Installation of Metal Flashing at Façade Transition not at Floorline

The following options for terminating metal flashing can be used for various exterior façade transitions. The cladding materials shown below are for general reference.

Option 1: Metal Flashing Terminated onto Tyvek® WRB

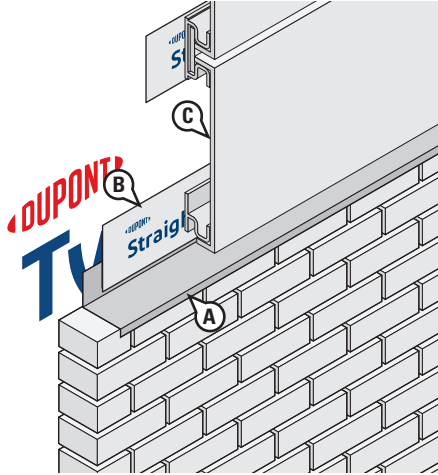

A. Install the “Z” or “L” metal flashing over the lower façade and onto the **Tyvek® WRB** with mechanical fasteners.

NOTE: Do not install **Tyvek® WRB** fasteners where the metal flashing or **DuPont Self-Adhered Flashing Product** will be installed.

B. Terminate the vertical leg of the metal flashing to **Tyvek® WRB** with **DuPont™ StraightFlash™** so there is a minimum of 2” adhesion onto the **Tyvek® WRB**.

C. Install the upper façade according to the manufacturer’s instructions.

Option 2: Metal Flashing Terminated onto Sheathing

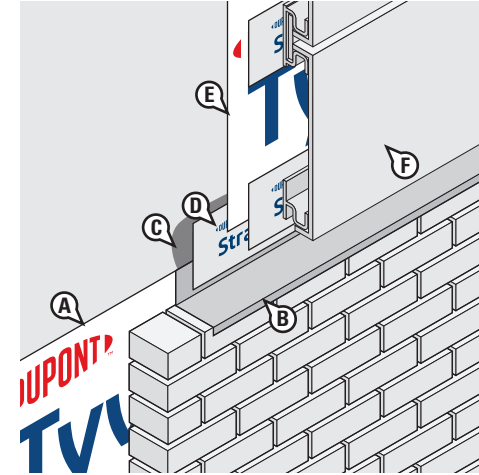

A. Install the first course of **Tyvek® WRB** so it extends a minimum of 2” **BEYOND** where the top edge of the lower façade will be located.

NOTE: Do not install **Tyvek® WRB** fasteners where the metal flashing or **DuPont Self-Adhered Flashing Product** will be installed.

B. Install the “Z” or “L” metal flashing along the top edge of the lower façade with the vertical leg overlapping the **Tyvek® WRB**. Vertical leg of metal flashing **should be** embedded in a recommended sealant to minimize potential of air and water infiltration.

C. Apply recommended adhesive/primer to exterior sheathing prior to the installation of **StraightFlash™**.

D. Terminate the vertical leg of the metal flashing directly to the sheathing with **StraightFlash™** with minimum of 2” adhesion onto the sheathing. **NOTE:** A recommended adhesive/primer is required for exterior gypsum sheathing.

E. Install the next course of **Tyvek® WRB** to overlap the **StraightFlash™** by a minimum of 2” and seal with **StraightFlash™**.

F. Install upper façade according to the manufacturer’s instructions.

DuPont™ Tyvek® WRB Installation Instructions (Windows/Doors Installed AFTER the Tyvek® WRB)

Continuity

Hybrid Wall – Transition to DuPont™ Tyvek® Fluid Applied Products

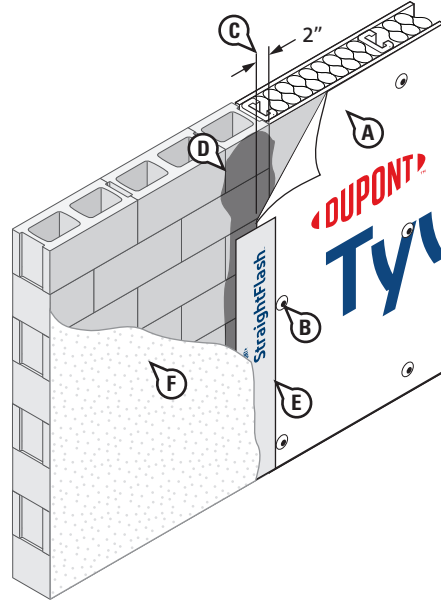

- A. Install **DuPont™ Tyvek® WRB** prior to application of **DuPont™ Tyvek® Fluid Applied WB+™**.
- B. Fasten the **Tyvek® WRB** to the stud adjoining the transition substrate.
- C. Cut the **Tyvek® WRB** so that approximately 2" will overlap the adjoining substrate.
- D. Fold back the 2" flap of **Tyvek® WRB** and prime adjoining substrate with a recommended adhesive/primer.
- E. Fold the **Tyvek® WRB** back down over the interface and terminate it to the primed substrate using 4" **DuPont™ StraightFlash™**, overlapping both surfaces evenly by approximately 2". Apply pressure along entire surface of flashing. Refer to the Special Consideration section for additional information.
- F. Apply **Tyvek® Fluid Applied WB+™** onto wall surface, overlapping the **StraightFlash™** by a minimum of 2". Refer to the [DuPont™ Tyvek™ Fluid Applied WB+™ Wall and Substrate Guidelines](#) for additional information.

Uncured DuPont™ Tyvek® Fluid Applied Products must not come in contact with Tyvek® WRBs due to potential impact on performance properties. Therefore, use of a spray guard or other physical barrier to avoid overspray onto the Tyvek® WRB is recommended.

- G. Upon completion, inspect surface to ensure that **Tyvek® Fluid Applied WB+™** is continuous and free of any voids or pinholes.

NOTE: When spraying, the outer edge of the **StraightFlash™** at the interface with the **Tyvek® Fluid Applied WB+™** can be treated with **DuPont™ Tyvek® Fluid Applied Flashing and Joint Compound+** tapered to the wall substrate to help ensure installation is free of pinholes and voids.

NOTE: The hybrid wall installation sequence capture in this detail is recommended when **Tyvek® WRB** is used with competitive fluid applied membrane.

DuPont™ Tyvek® WRB Installation Instructions (Windows/Doors Installed AFTER the Tyvek® WRB)

Continuity

Concrete Cantilevers or Balconies

Seal to concrete cantilevers using **DuPont Self-Adhered Flashing Products** and a recommended adhesive/primer.

NOTE: Cantilever and balcony conditions vary. The detail below captures one typical cantilever condition with a termination of the **Tyvek® WRB** along the bottom and side surfaces of the cantilever prior to sealing the **Tyvek® WRB** flap. Ensure proper shingling of **DuPont Self-Adhered Flashing Products** and terminations of the **Tyvek® WRB**. Contact your local DuPont Representative for more information regarding additional cantilever or balcony conditions.

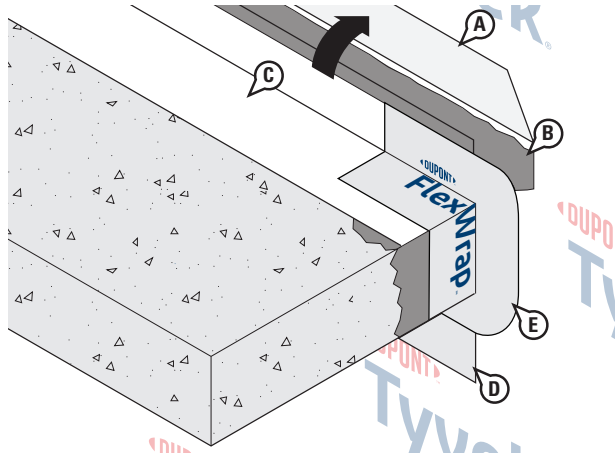

STEP 1

- Cut and flip up the **Tyvek® WRB** flap.
- Prime substrates with a recommended adhesive/primer.
- Install waterproofing sheet membrane or metal flashing per plans and specifications and/or manufacturer's requirements. Metal flashing recommended to be embedded in sealant.
- Seal the **Tyvek® WRB** to bottom of cantilever or balcony with **DuPont™ StraightFlash™**.
- Wrap **DuPont™ FlexWrap™** around cantilever or balcony edge. **NOTE:** Ensure **FlexWrap™** will not be exposed after completion of cladding.

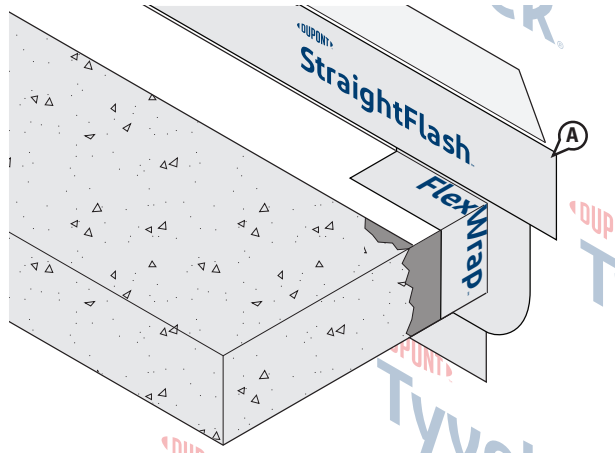

STEP 2

- Apply 4" **StraightFlash™** over **FlexWrap™** and top edge of the metal flashing, when used.

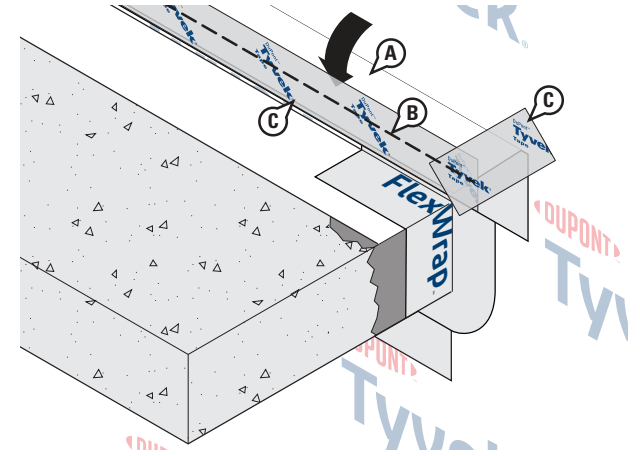

STEP 3

- Flip down **Tyvek® WRB** flap.
- Trim ~1" strip along horizontal edge of **Tyvek® WRB** flap
- Tape seams using a minimum 3" width **DuPont™ Tyvek® Tape** or a **DuPont Self-Adhered Flashing Product**.

DuPont™ Tyvek® WRB Installation Instructions (Windows/Doors Installed AFTER the Tyvek® WRB)

Continuity

Concrete Column

Method 1

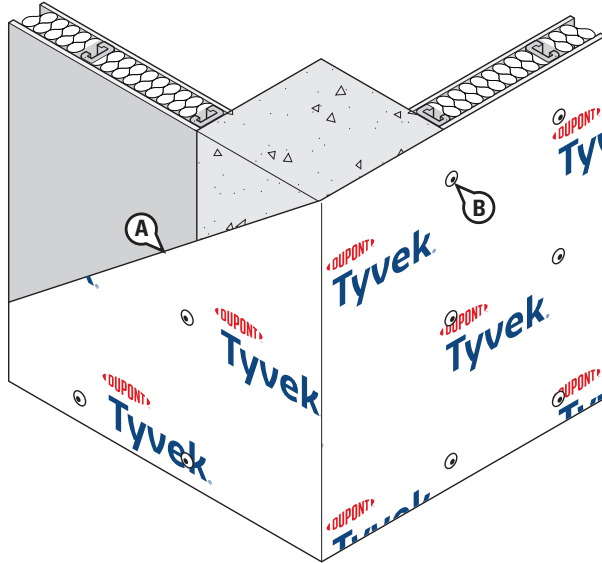

- A. Wrap **DuPont™ Tyvek® WRB** around concrete column.
- B. Mechanically fasten **Tyvek® WRB** at recommended spacing. (See Recommended Fasteners and Spacing section of this document)

NOTE: Mechanically fasten **Tyvek® WRB** to concrete column if necessary to maintain recommended fastener spacing.

Method 2

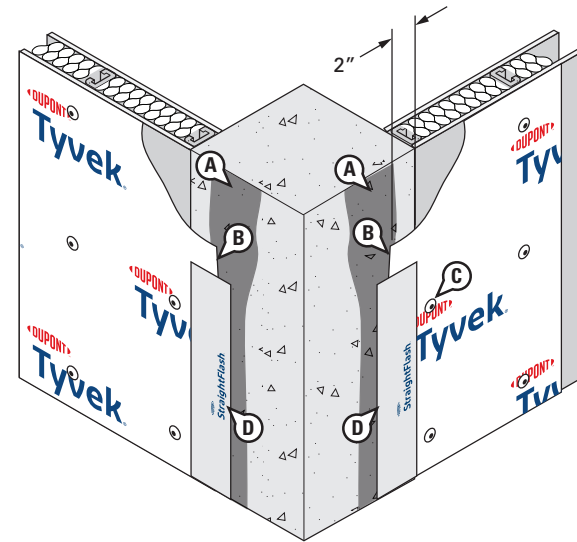

- A. Prime concrete column with a recommended adhesive/primer.
- B. Cut **Tyvek® WRB** at concrete column, leaving approximately 2" overlapping column.
- C. Mechanically fasten **Tyvek® WRB** into studs.
- D. Terminate **Tyvek® WRB** to concrete using **DuPont™ StraightFlash™**.

NOTE: For high performance installations, additional fasteners may be necessary to secure **StraightFlash™**. Use appropriate fastener for each substrate.

DuPont™ Tyvek® WRB Installation Instructions (Windows/Doors Installed AFTER the Tyvek® WRB)

Continuity

Parapet Wall with Brick

Method 1

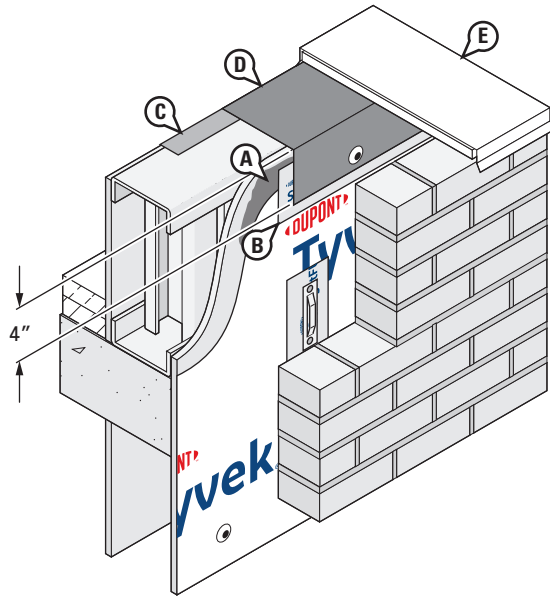

- A. Apply a recommended adhesive/primer to wall surface or exterior sheathing at top of wall. Primer not required for clean metal framing.
- B. Install a minimum 4" DuPont™ StraightFlash™ to terminate the Tyvek® WRB.
- C. Install roofing membrane (by others).
- D. Install through wall flashing over parapet wall, overlapping the Tyvek® WRB and the roofing membrane by a minimum of 4" in the proper shingling manner.
- E. Install coping cap.

NOTE: The roofing membrane and through wall flashing (by others) over the parapet wall may be one (the same) product.

Method 2

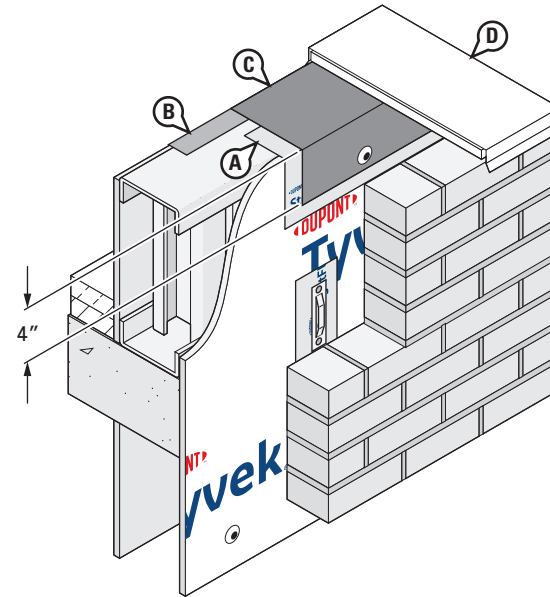

- A. Ensure Tyvek® WRB is cut flush at the top of wall. Install 9" StraightFlash™ to terminate the Tyvek® WRB. Flashing should be installed to ensure 5"– 6" adhesion to the Tyvek® WRB.
- B. Install roofing membrane (by others).
- C. Install through wall flashing over parapet wall, overlapping the Tyvek® WRB and the roofing membrane by a minimum of 4" in the proper shingling manner.
- D. Install coping cap.

NOTE: The roofing membrane and through wall flashing (by others) over the parapet wall may be one (the same) product.

NOTE: Additional CAD details are available in the Technical Information section of building.dupont.com.

DuPont™ Tyvek® WRB Installation Instructions (Windows/Doors Installed AFTER the Tyvek® WRB) Continuity

Top of Wall Termination at Inside Corner when using Method 2 of the Parapet Wall with Brick

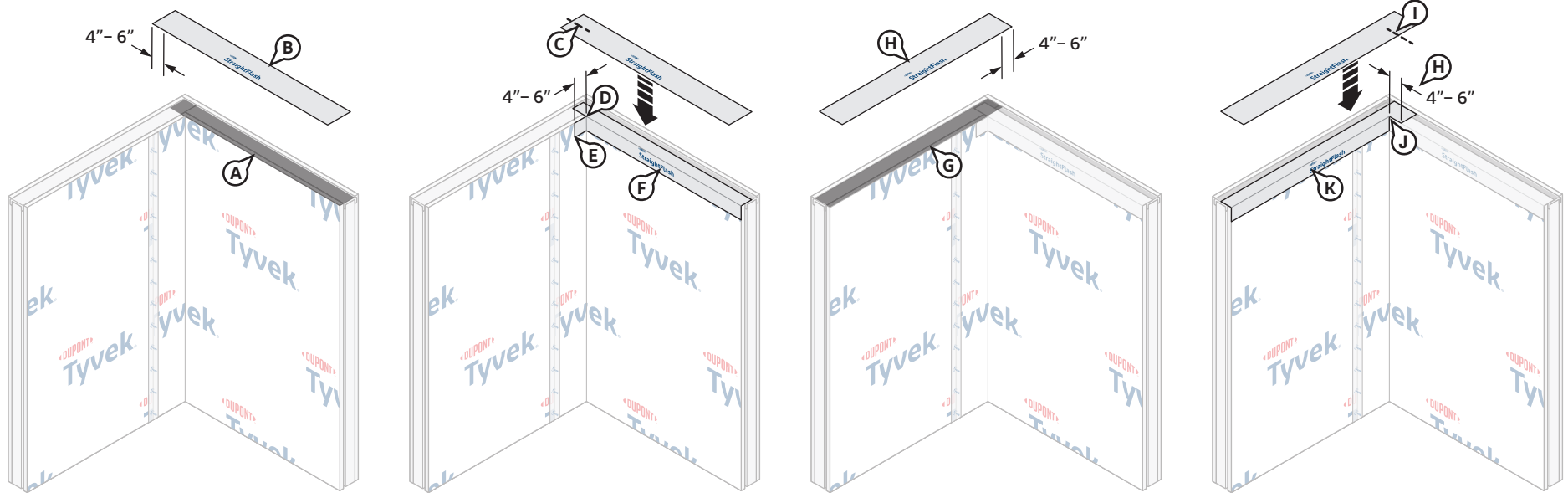

- A. Prime the top of wall with a recommended adhesive/primer.
- B. Prepare 9" **DuPont™ StraightFlash™** for installation and ensure flashing extends 4"– 6" on the top of the adjacent wall surface beyond the edge of the inside corner.
- C. Create a slit in the **StraightFlash™** parallel to the wall plane that extends to/from the inside corner to the edge of the flashing.
- D. Align the end of the slit with the inside corner. Remove release paper for flashing positioned over the horizontal wall plane. Ensure the installation of 9" **StraightFlash™** has 3"– 4" adhered along the top of the wall surface and 5"– 6" adhered to the face of the **Tyvek® WRB**. Adhere **StraightFlash™** to horizontal plane.
- E. Remove the remaining release paper and gently fold **StraightFlash™** onto the face of **Tyvek® WRB** and into the inside corner.
- F. Use firm hand pressure or a j-roller on the **StraightFlash™** to ensure proper adhesion.
- G. Prime the top of the adjacent wall with a recommended adhesive/primer
- H. Prepare 9" **StraightFlash™** for installation and align along top of wall. Ensure flashing extends 4"– 6" beyond the edge of the inside corner.
- I. Create a slit in the **StraightFlash™** prior to installation. The slit should extend from the inside corner to edge of flashing. Be careful not to cut through previously installed flashing and/or **Tyvek® WRB**.
- J. Align the end of the slit with the inside corner. Remove release paper for flashing position over the adjacent horizontal wall plane. Adhere **StraightFlash™** to horizontal plane.
- K. Remove the remaining release paper and gently fold **StraightFlash™** onto the face of **Tyvek® WRB** and into the inside corner.
- L. Apply a recommend sealant to the pinhole area.

DuPont™ Tyvek® WRB Installation Instructions (Windows/Doors Installed AFTER the Tyvek® WRB)

Continuity

Top of Wall – Outside Corner when using Method 2 of the Parapet Wall with Brick

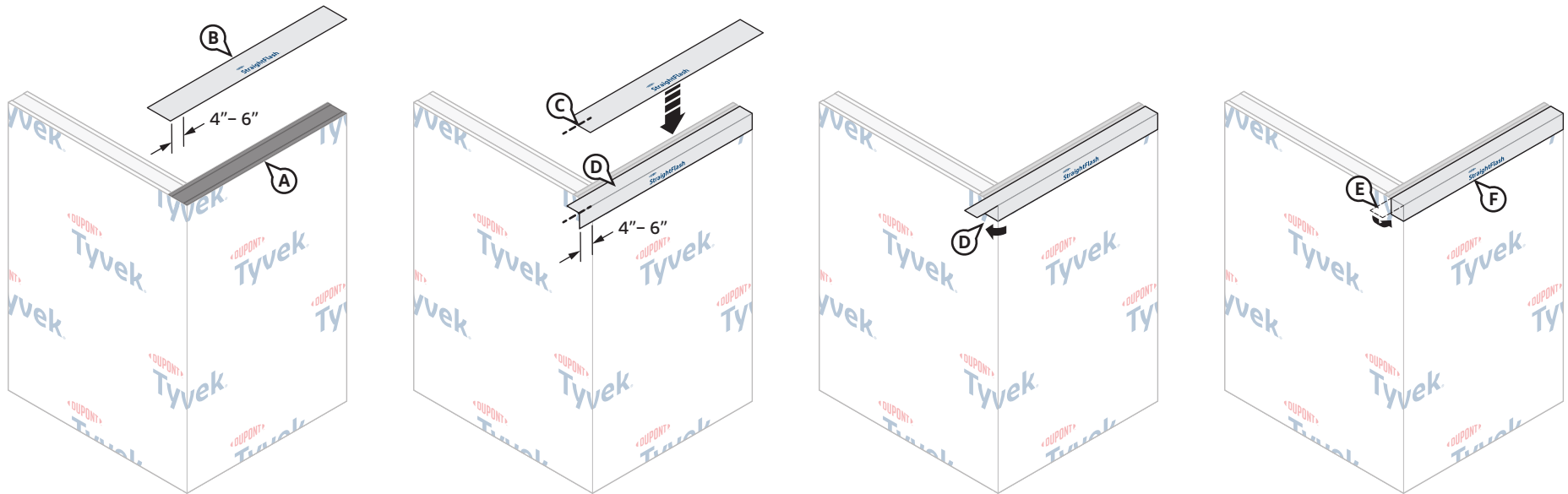

STEP 1

- A. Prime the top of wall with a recommended adhesive/primer.
- B. Prepare 9" **DuPont™ StraightFlash™** for installation and ensure flashing extends 4"-6" on the top of the adjacent wall surface.
- C. Create a slit in the **StraightFlash™** parallel to the wall plane that extends to/from the outside corner to the edge of the flashing. Align the end of the slit with the outside corner.
- D. Remove release paper for portion of **StraightFlash™** positioned over the horizontal wall plane. Adhere **StraightFlash™** to horizontal plane. Remove remaining release paper and folding **StraightFlash™** onto the **Tyvek® WRB**. Ensure the installation of 9" **StraightFlash™** has 3"-4" adhered along the top of the wall surface and 5"-6" adhered to the face of the **Tyvek® WRB**.
- E. Remove the remaining release paper and gently fold flashing onto the face of the **Tyvek® WRB** and into the inside corner.
- F. Use firm hand pressure or a j-roller on the **StraightFlash™** to ensure proper adhesion.

DuPont™ Tyvek® WRB Installation Instructions (Windows/Doors Installed AFTER the Tyvek® WRB)

Continuity

Top of Wall – Outside Corner when using Method 2 of the Parapet Wall with Brick

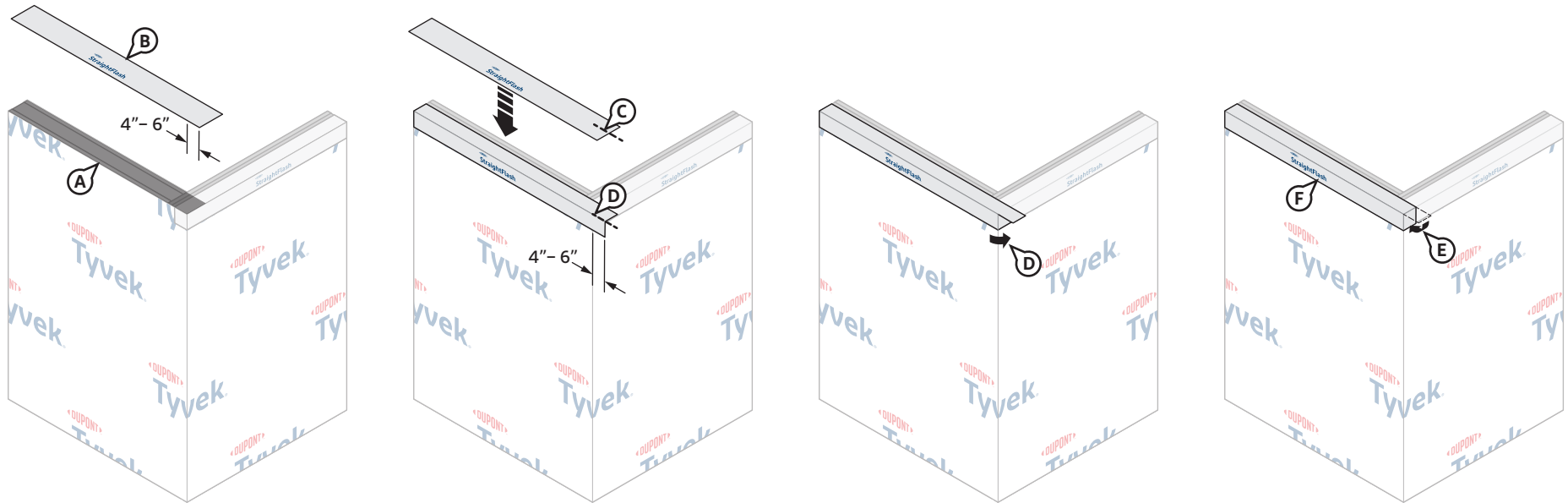

STEP 2

- A. Prime the top of the adjacent wall with a recommended adhesive/primer.
- B. Prepare 9" **DuPont™ StraightFlash™** for installation and align along top of wall. Ensure flashing extends 4"– 6" beyond the edge of the inside corner.
- C. Create a slit in **StraightFlash™** prior to installation. The slit should extend from the outside corner to edge of flashing. Be careful not to cut through previously installed **StraightFlash™** and/or **Tyvek® WRB**.
- D. Align the end of the slit with the inside corner. Remove release paper for flashing position over the adjacent horizontal wall plane. Ensure the installation of 9" **StraightFlash™** has 3"– 4" adhered along the top of the wall surface and 5"– 6" adhered to the face of the **Tyvek® WRB**. Adhere **StraightFlash™** to horizontal plane.
- E. Remove the remaining release paper and gently fold flashing to face of **Tyvek® WRB**.
- F. Use firm hand pressure or a j-roller on the **StraightFlash™** to ensure proper adhesion.
- G. Apply recommend sealant to the pinhole area.

DuPont™ Tyvek® WRB Installation Instructions (Windows/Doors Installed AFTER the Tyvek® WRB)

Continuity

Inside Corner Transition to Concrete

Method 1

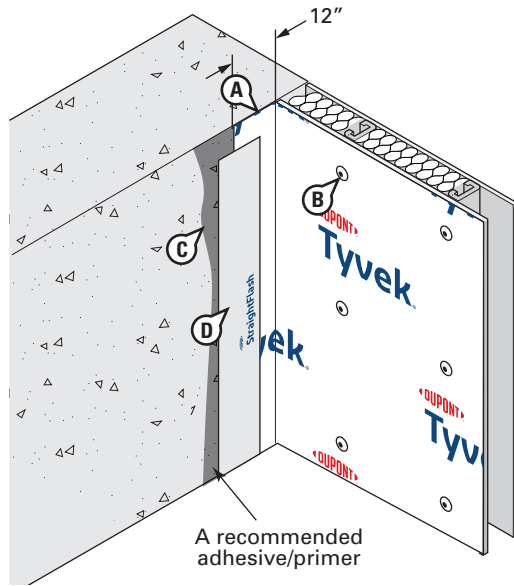

- A. Cut **DuPont™ Tyvek® WRB** so there is approximately 12" overlapping concrete.
- B. Mechanically fasten **Tyvek® WRB** to studs.
- C. Prime concrete with a recommended adhesive/primer.
- D. Terminate **Tyvek® WRB** to concrete using **DuPont™ StraightFlash™**.

NOTE: For high performance installations, additional fasteners may be necessary to secure **StraightFlash™**. Use appropriate fastener for each substrate.

Method 2

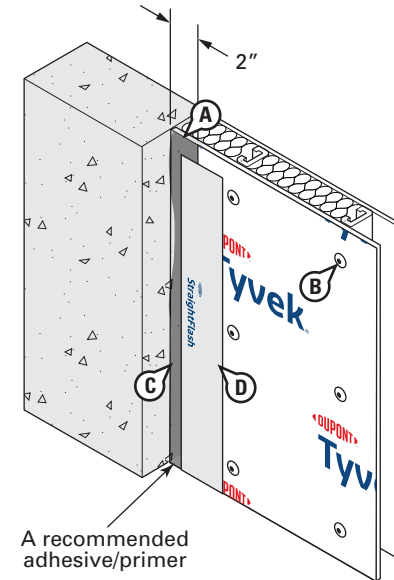

- A. Cut **Tyvek® WRB** to expose approximately 2" of the wall.
- B. Mechanically fasten **Tyvek® WRB** to studs.
- C. If necessary, prime wall adjacent to concrete with a recommended adhesive/primer.
- D. Terminate **Tyvek® WRB** to the wall using **StraightFlash™**.

NOTE: For high performance installations, additional fasteners may be necessary to secure **StraightFlash™**.

DuPont™ Tyvek® WRB Installation Instructions (Windows/Doors Installed AFTER the Tyvek® WRB)

Penetrations

Seal around plumbing pipes, HVAC components, electrical outlets, exterior lights, flashing panels, and other objects that penetrate the **DuPont™ Tyvek® WRB**. Always use positive shingling by installing **Tyvek® WRBs** and **DuPont Self-Adhered Flashing Products** from bottom to top, with upper layer installed over lower layer.

Flashing Integral Flanged Products Installed AFTER DuPont™ Tyvek™ WRB

Method 1

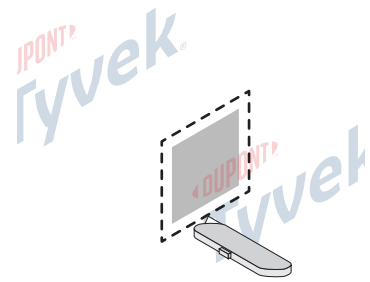

STEP 1

Install **Tyvek® WRB** and cut as necessary to accommodate integral flanged product.

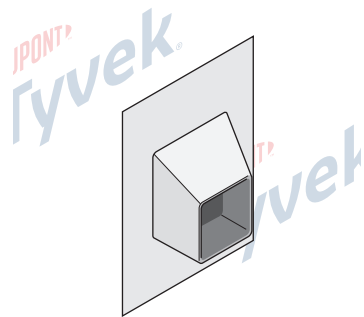

STEP 2

Install integral flanged product per manufacturer's instructions.

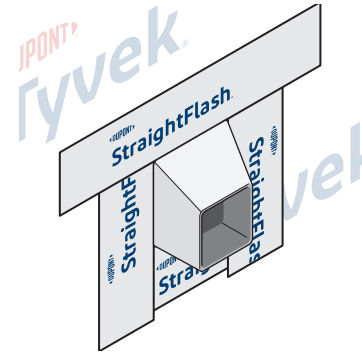

STEP 3

Install **DuPont Self-Adhered Flashing Product** onto bottom, sides, and top flanges, extending onto **Tyvek® WRB** by a minimum of 2".

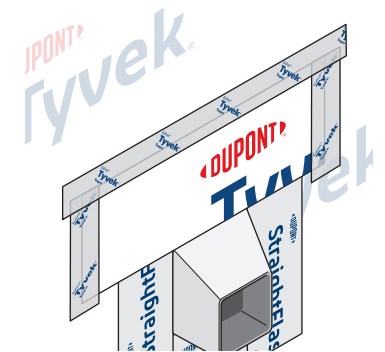

STEP 4 (OPTIONAL)

Install a piece of **Tyvek® WRB** to overlap the top edge of the **DuPont Self-Adhered Flashing Product**. Seal sides and top with **DuPont™ Tyvek® Tape**.

Method 2

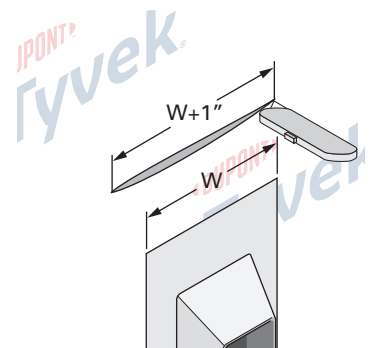

STEP 1

Install **Tyvek® WRB** and make horizontal cut a minimum of 1" wider than flange.

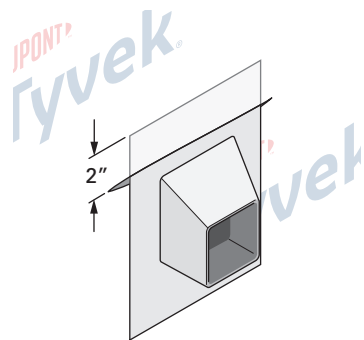

STEP 2

Slide top flange into slit with minimum 2" overlap of **Tyvek® WRB**, and install per manufacturer's instructions.

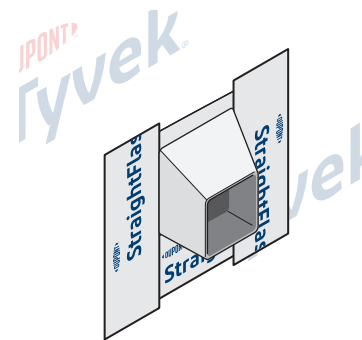

STEP 3

Adhere **DuPont Self-Adhered Flashing Product** onto bottom and side flanges, extending onto **Tyvek® WRB** by 2".

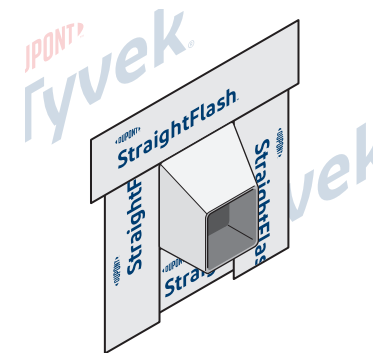

STEP 4

Install **DuPont Self-Adhered Flashing Product** to top flange, extending beyond **DuPont Self-Adhered Flashing Product** on side flanges.

DuPont™ Tyvek® WRB Installation Instructions (Windows/Doors Installed AFTER the Tyvek® WRB) Penetrations

Option 1: Flashing Non-Flanged AFTER Installation of DuPont™ Tyvek® WRB Using DuPont™ FlexWrap™ EZ

For non-flanged products with **OD GREATER** than 2"

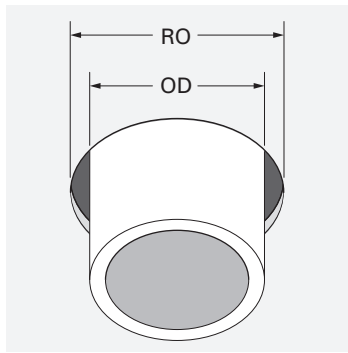
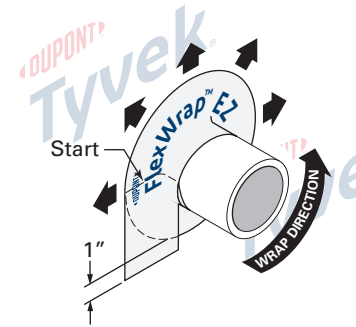
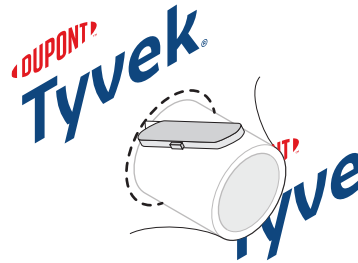

STEP 1

Install **Tyvek® WRB** over non-flanged product and cut around penetration.

STEP 2

Cut a piece of **FlexWrap™ EZ** longer than circumference of non-flanged product to ensure a minimum 1" overlap onto the **Tyvek® WRB**. Starting at the horizontal position on either side, adhere around penetration and onto **Tyvek® WRB**.

For non-flanged products with **OD LESS** than 2"

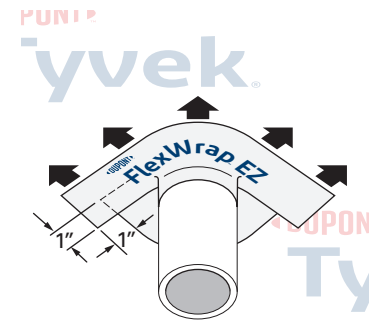
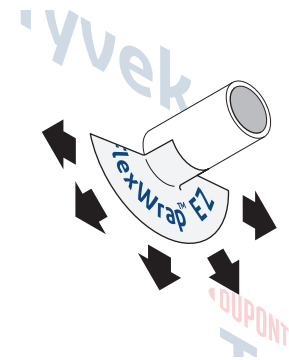
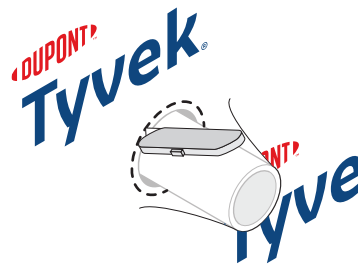

Use **FlexWrap™ EZ** only when penetration rough opening (RO) is not more than ½" larger than the outside diameter/ dimension (OD) of non-flanged product.

NOTE: For more information regarding the installation of **FlexWrap™ EZ**, refer to the Installation Information Bulletin for **FlexWrap™ EZ**.

STEP 1

Install **Tyvek® WRB** over non-flanged product and cut around penetration.

STEP 2

Cut a piece of **FlexWrap™ EZ** the length of ½ the circumference of the non-flanged product. Adhere onto bottom section and fan out onto **Tyvek® WRB**.

STEP 3

Cut a second piece of **FlexWrap™ EZ** the length of the pipe circumference. Adhere onto top section and fan out onto face of wall with a minimum of 1" overlap of the edges of **FlexWrap™ EZ** below.

DuPont™ Tyvek® WRB Installation Instructions (Windows/Doors Installed AFTER the Tyvek® WRB) Penetrations

Option 2: Flashing Non-Flanged Products AFTER Installation of DuPont™ Tyvek® WRB Using DuPont™ FlexWrap™

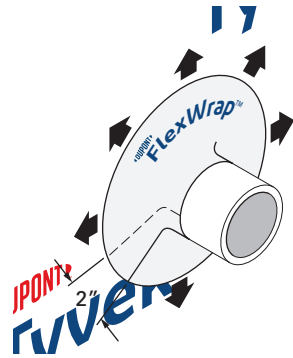

STEP 1

Install **Tyvek® WRB** over non-flanged product and cut around penetration.

STEP 2

Working counterclockwise, install **FlexWrap™** around penetration with a minimum 2" overlap.

Flashing Integral Flanged Products BEFORE Installation of DuPont™ Tyvek® WRB

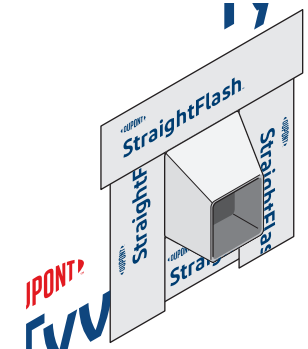
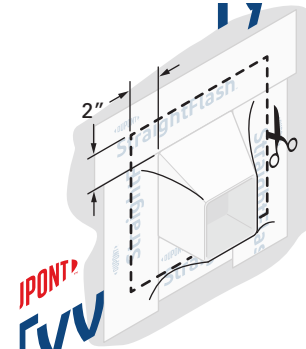
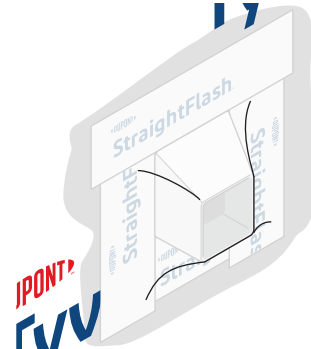
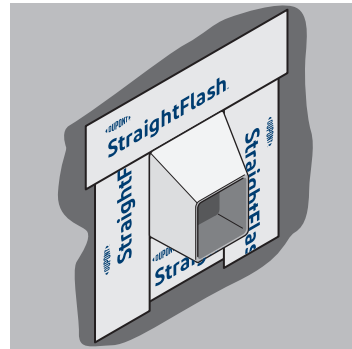
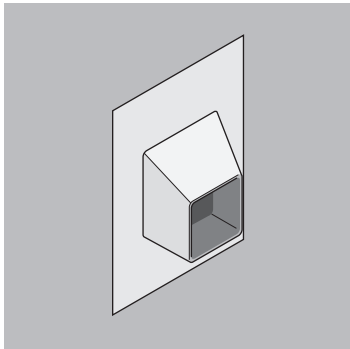

STEP 1

Install integral flanged product onto sheathing per manufacturer's instructions.

STEP 2

Prime as necessary with a recommended adhesive/primer. Install **DuPont™ StraightFlash™** or **DuPont™ Flashing Tape*** onto flanges, extending onto sheathing by a minimum of 2".

STEP 3

Install **Tyvek® WRB**.

STEP 4

Make cut in **Tyvek® WRB**, ensuring a minimum of 2" gap for adhesion of **StraightFlash™**.

STEP 5

Seal edges of **Tyvek® WRB** with **StraightFlash™**.

*DuPont™ Flashing Tape is only permitted for Residential-Use building structures. Residential-Use (Group R) is defined by the 2015/2018 International Building Code.

DuPont™ Tyvek® WRB Installation Instructions (Windows/Doors Installed AFTER the Tyvek® WRB)

Recommended Fasteners and Spacing

- 2" DuPont™ Tyvek® Wrap Cap Screws (for steel or wood frame construction)
- 1-1/4" metal gasketed washers with screws (for steel frame construction)
- 2" metal gasketed washers with screws (for steel frame construction)
- Tapcon® fasteners with 2" plastic caps (for masonry construction)
- TRUFAST® Walls* Grip-Deck® screws with Thermal-Grip FastCap™ washers installed at 16" vertical spacing along stud lines for 16" o.c. framing.

Metal frame construction:

- 1 5/8" – 6" TRUFAST® Walls* Grip-Deck® Self-Drilling screws with 2" dia. Thermal-Grip FastCap™ washer.
- 1-5/8", 2", 2-1/2", and 3" screws can be installed with standard hand drill or Grip-Lok® Autofeed Fastening System** with modified nose adaptor.
- 3-1/2" to 6" screws should be installed with standard hand drill
- A minimum of 4 threads screw penetration through the steel stud is required.

Wood frame construction:

- 1-5/8" – 6" TRUFAST® Walls* Grip-Deck® HiLo Thread Screws with 2" Thermal-Grip FastCap™ washer
- 1-5/8" screws can be used for structural loading performance requirements per ASTM E2357 and water infiltration resistance up to 9 psf, installed with standard hand drill or Grip-Lok® Autofeed Fastening System** with modified nose adaptor.
- 2" or longer screws must be used for structural loading performance requirements per ASTM E2357 and water infiltration resistance up to 15 psf installed with standard hand drill or Grip-Lok® Autofeed Fastening System** with modified nose adaptor. A minimum 1" of screw penetration into the wood stud is required for assemblies requiring 15 psf water infiltration resistance.
- 3-1/2" to 6" screws should be installed with standard hand drill.

NOTE: The recommended fasteners listed above should be secured to the framing member. It is **not acceptable** for screw fasteners to be attached to the exterior sheathing only. Recommended screw cap fasteners that miss the framing member should be removed and the hole repaired/covered with 3" DuPont™ Tyvek® Tape or patch of DuPont Self-Adhered Flashing Product.

NOTE: The recommended fasteners listed above can be used in conjunction with facade fasteners to obtain the desired wind load performance and vertical fastener spacing captured in Table 1.

*TRUFAST® Walls (formerly Rodenhouse)

**For more information about the Grip-Lok® Autofeed Fastening System, refer to manufacturer's instructions and contact your local DuPont™ Tyvek® Specialist.

Table 1 – DuPont™ Tyvek® WRB with Screw Fasteners and 16" and 24" O.C. Steel Stud Spacing

Washer Size	Fastener Spacing inches	Vertical Stud Spacing O.C. inches	Allowable Pressure	
			psf	mph
2" Metal Gasketed Washer	8	24	90	188
	12	16	90	188
	12	24	60	153
	18	16	60	153
	16	24	45	133
2" DuPont™ Wrap Cap Screw	24	16	45	133
	8	24	60	153
	12	16	60	153
	12	24	45	133
1.25" Metal Gasketed Washer	18	16	45	133
	12	16	60	153
	18	16	40	125

Temporary Fastening

Selection and use of temporary fastening methods is an option dependent on building schedule, cladding options, and local building practices. Temporary fasteners should not be relied upon to permanently attach the Tyvek® WRB due to the limited holding power of these fastening methods. If temporary fasteners are used, permanent fastening should be applied as soon as practically possible in order to maintain the integrity and performance of the Tyvek® WRB.

Temporary fastening methods:

- DuPont recommended fasteners at a reduced schedule 24" to 48".
- A recommended adhesive applied in vertical strips at 24" to 36" spacing or along every other stud line. Vertical strips may be applied to the outer face of the sheathing or directly to the studs for open stud construction. When using adhesives, care must be taken to avoid excessive surface coverage as this may impact the vapor permeability of the Tyvek® WRB in that area. Refer to [Chemical Compatibility of Representative Building Sealants and Adhesives/Primers](#) for more information about recommended adhesives.
- #4 nails with 1" plastic cap (for wood frame construction)
- 1" plastic cap staple with leg length sufficient to achieve 5/8" penetration into wood stud (for wood frame construction).
- If staples without caps are used to temporarily fasten Tyvek® WRBs to exterior sheathing, the fastening schedule must not exceed 4 per square yard and each staple must be covered with 3" DuPont™ Tyvek® Tape. Covering the staples underneath a taped WRB seam is acceptable.

Temporary fastening methods may not be suitable for high performance installations. For additional guidance, please consult your local DuPont™ Tyvek® Specialist.

DuPont™ Tyvek® WRB Installation Instructions (Windows/Doors Installed AFTER the Tyvek® WRB)

Alternate Fastening

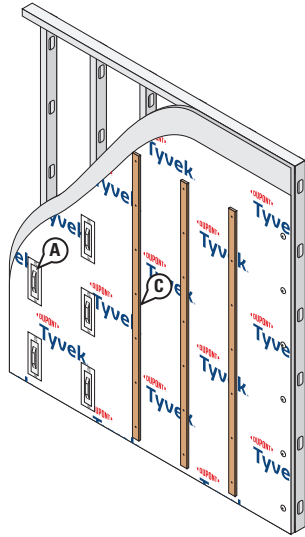

When the building envelope design requirements **exceed** ASTM E1677, (65 mph equivalent structural load and 15 mph equivalent wind-driven rain water infiltration resistance) and/or when water infiltration field testing is specified, the following items must be accounted for.

- A. **DuPont™ StraightFlash™**, **DuPont™ Flashing Tape**, or recommended alternate self-adhered flashing is **required** behind standard brick tie base plates and metal plates.
- B. **StraightFlash™**, **DuPont™ Flashing Tape**, or recommended alternate self-adhered flashing is **required** behind fasteners for metal hat channels, z-girts, knight-wall, etc.
- C. DuPont **does not require DuPont Self-Adhered Flashing Products** behind unshimmed wood furring strips mounted vertically.

NOTES:

- It is important to consider minimizing the total number of fasteners used to attach the **DuPont™ Tyvek® WRB**. When using cladding fasteners such as brick ties, metal plates, or hat channels, **Tyvek® WRB** can be attached at a reduced fastener schedule. Refer to the [Temporary Fastening](#) section for information about reducing the recommended fastener schedule.
- **StraightFlash™**, **DuPont™ Flashing Tape**, or recommended alternate self-adhered flashing **must be** adhered to the **Tyvek® WRB** behind fastening plates (brick tie base plates, metal fastening clips, metal channels, z-girts, shimmed furring strips, etc.) when building envelope design requirements exceed ASTM E1677.
- **StraightFlash™**, **DuPont™ Flashing Tape**, or recommended alternate self-adhered flashing is **not required** behind Hohmann and Barnard 2-Seal™ Tie, Heckmann™ Pos-I-Tie®, and TRUFAST® Walls Grip-Deck TubeSeal™ and/or Thermal-Grip® MVA fasteners.

Handling Tears and Holes

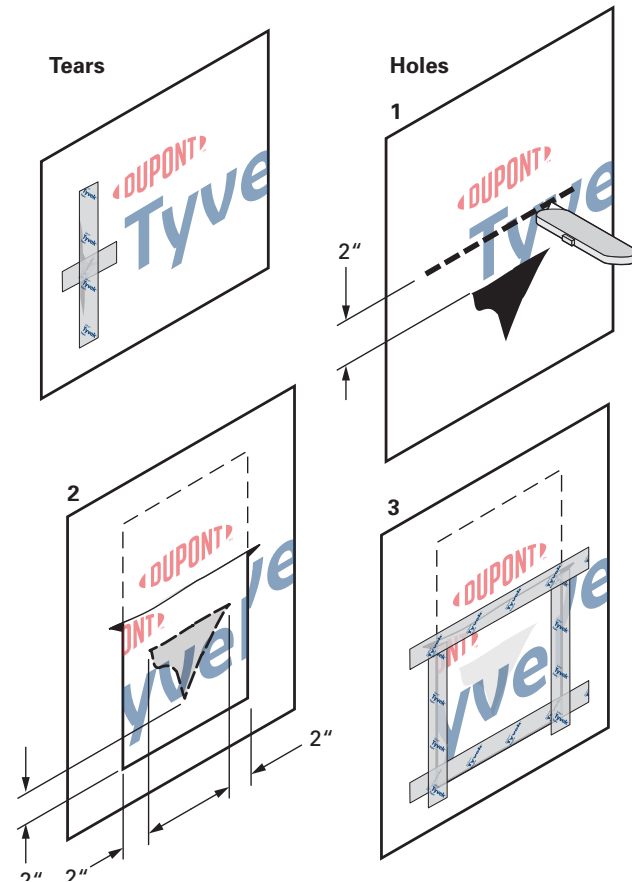

- During the course of installing the **DuPont™ Tyvek® WRB**, minor tears may occur. Be sure to tape all tears. Tears can easily be covered with 3" **DuPont™ Tyvek® Tape** or **DuPont Self-Adhered Flashing Products**.
- Larger tears may require cutting a piece of **Tyvek® WRB** to repair the tear. Measure and cut a piece of **Tyvek® WRB** large enough to cover tear with an excess of 2" around the tear plus an extra 6" in height. Cut a slit 2" above the tear large enough to accommodate the patch. Tuck patch into slit at least 6" and shingle over lower **Tyvek® WRB**. 3" **Tyvek® Tape** must be applied along the perimeter by starting at bottom of tear and shingling the upper tape over the bottom tape.

Installation Methods for DuPont Self-Adhered Flashing Products Installed AFTER the DuPont™ Tyvek® WRB

Key Installation Requirements for Drainable Window / Door Installation

When flashing windows or doors, the following principles must be followed:

- An integral flanged window/door is defined as a window/door unit with a nailing fin or flange that is continuous around the perimeter of the window and that is a direct extrusion of the window frame.
 - A non-integral flanged window/door is defined as a window/door unit with a nailing fin or flange that is not continuous around the perimeter of the window/door or the fin/flange is not a direct extrusion of the frame (e.g. field-applied flanges).
 - When installed properly, **DuPont™ StraightFlash™**, **DuPont™ VersaFlange™**, **DuPont™ FlexWrap™**, and **DuPont™ Flashing Tape** provide nail sealability at window/door openings to help protect critical window-wall interfaces. Metal sill pan flashing may be used, but must not replace flexible sill flashing that provides nail sealability.
 - **DuPont Self-Adhered Flashing Products** comply with AAMA 711, *Voluntary Specification for Self Adhering Flashing Used for Installation of Exterior Wall Fenestration Products*, which has a modified version of ASTM D1970 and it is more representative for vertical wall applications.
 - **DuPont™ Tyvek® Fluid Applied Flashing and Joint Compound+** complies with AAMA 714, *Voluntary Specification for Liquid Applied Flashing Used to Create a Water-Resistive Seal around Exterior Wall Openings in Buildings*.
 - Ensure that sill flashing does not slope to the interior. An exterior slope is recommended, but not required.
 - Direct water onto an acceptable air and water barrier drainage plane with an unobstructed path to the exterior of the wall. Provide a drainage path for any water intrusion through the window/door attachment system that collects at the sill.
 - Properly integrate flashing with acceptable **DuPont™ Tyvek® WRB** in accordance with the instructional drawing. Self-adhered flashing must be applied with a minimum 2" lap onto the WRB.
 - DuPont requires that **FlexWrap™**, **FlexWrap™ EZ**, **StraightFlash™**, **VersaFlange™**, and **Tyvek® Fluid Applied Flashing and Joint Compound+** be covered within nine months (270 days) of installation. DuPont requires that **DuPont™ Flashing Tape** be covered within four months (120 days) of installation.
 - Properly prepare all surfaces (remove dirt, dust, or moisture, etc.) per manufacturer's recommendations.
- Barrier installations (full perimeter seal on exterior) are acceptable only in the following instances:
 - Slab on grade doors, storefront windows, or other systems with built-in drainage mechanisms that have potential for exposure to standing water
 - Surface barrier wall systems with non-water sensitive framing material (i.e., CMU walls)
 - Very low wind / rain exposure regions (southwest / desert) that follow AAMA 2400 installation guideline
 - Ensure that window / door and flashing system design takes into account common factors that will impact performance, such as:
 - Climate considerations: Rainfall, Wind, Temperature (hot / cold cycles), Humidity
 - Building design: Window / Wall Design (soffits, recessed openings, bump-outs), Wall Assembly (steel frame or masonry), Window System (non-flanged, storefront, curtain wall, wood, or vinyl), New Construction or Replacement Window drainage path
 - UV exposure prior to the construction of the exterior facade
 - Compliance with fire resistance code requirements. For more information about NFPA 285 compliant wall assemblies utilizing **Tyvek® WRBs** and **DuPont™ Tyvek® Fluid Applied WB+™** visit building.dupont.com.
 - Field testing the window / door and wall installation as a complete system is a recommended best practice.
 - Use of trained installers is highly recommended.

Sealants and Adhesives/Primers

Review the manufacturers' literature or label to confirm that the product(s) used have the chemical and adhesive properties necessary for use with **Tyvek® WRBs**, **DuPont Self-Adhered Flashing Products**, and **DuPont™ Tyvek® Fluid Applied Products**. Ensure the sealant materials meet the installation temperature requirements of the sealant manufacturer. Refer to [Chemical Compatibility of Representative Building Sealants and Adhesives/Primers](#) for more information about chemical compatibility.

Installation Methods for DuPont Self-Adhered Flashing Products Installed **AFTER** the DuPont™ Tyvek® WRB Non-Flanged Windows and Doors (Using “Wrap the Cavity” Method)

This method applies to the following products: DuPont™ StraightFlash™ and DuPont™ FlexWrap™

The steps below can be used for the following details: Non-Flanged Windows, Non-Flanged Doors, Brick Mold Windows, Brick Mold Doors, Storefront Windows on Slabs, Storefront Windows on Knee Walls, and Scuppers.

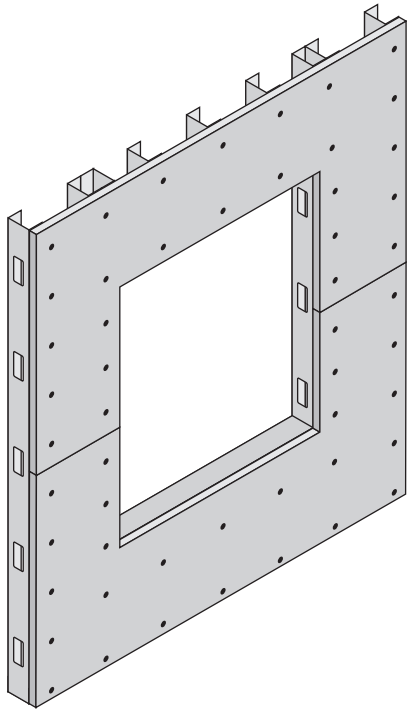

STEP 1

- A. Cut rough opening in sheathing for window. Ensure that sheathing is cut flush with, or slightly below the sill framing to allow for positive drainage.

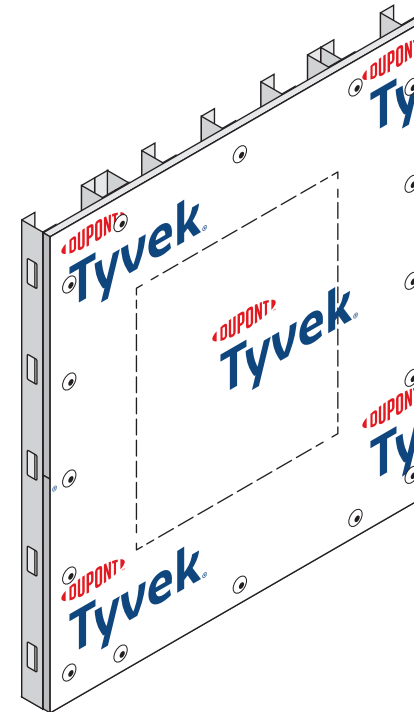

STEP 2

- A. Wrap wall as shown in the [DuPont™ Tyvek® WRB Installation Instructions](#) section in this guide. Do not install fasteners within 6” of the sills and jambs of the openings and within 9” of the head of the openings.

Installation Methods for DuPont Self-Adhered Flashing Products Installed **AFTER** the DuPont™ Tyvek® WRB Non-Flanged Windows and Doors (Using “Wrap the Cavity” Method)

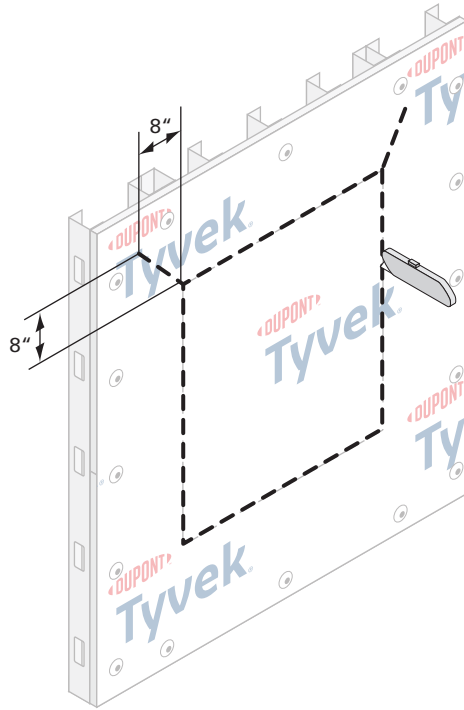

STEP 3

Prepare the Tyvek® WRB for Window Installation

- Cut an opening in the Tyvek® WRB using a flush cut (“O-Cut”) around the perimeter of the rough opening.
- Cuts should be made along the dashed indicated lines. (Ensure that the Tyvek® WRB is cut flush with the sheathing and is not wrapped into the rough opening.)
- Cut a head flap at a 45° angle to expose 8” of sheathing to allow for head flashing installation.

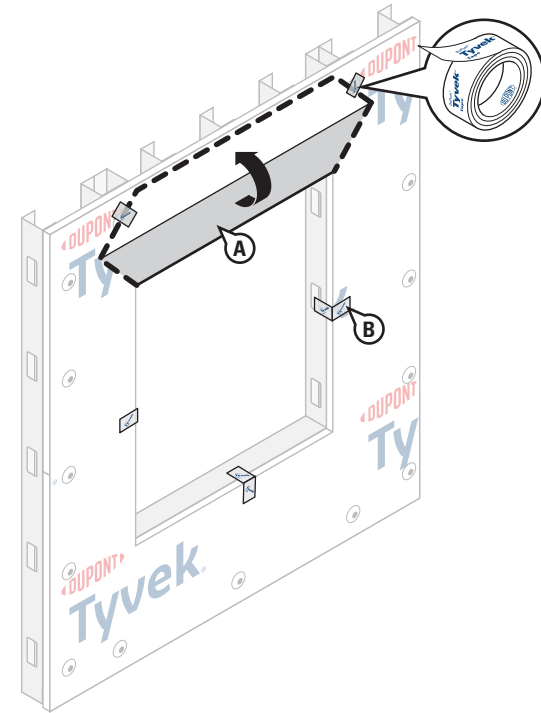

STEP 4

- Flip the head flap up to expose the sheathing and temporarily secure flap with tape.
- Temporarily secure the Tyvek® WRB with DuPont™ Tyvek® Tape around rough opening before flashing is installed to help facilitate flashing installation.

NOTE: In lieu of temporarily taping, the head flap can be tucked under the Tyvek® WRB, as a alternate method to secure head flap.

NOTE: Some windows and flashing widths may require longer slits.

Installation Methods for DuPont Self-Adhered Flashing Products Installed **AFTER** the DuPont™ Tyvek® WRB Non-Flanged Windows and Doors (Using “Wrap the Cavity” Method)

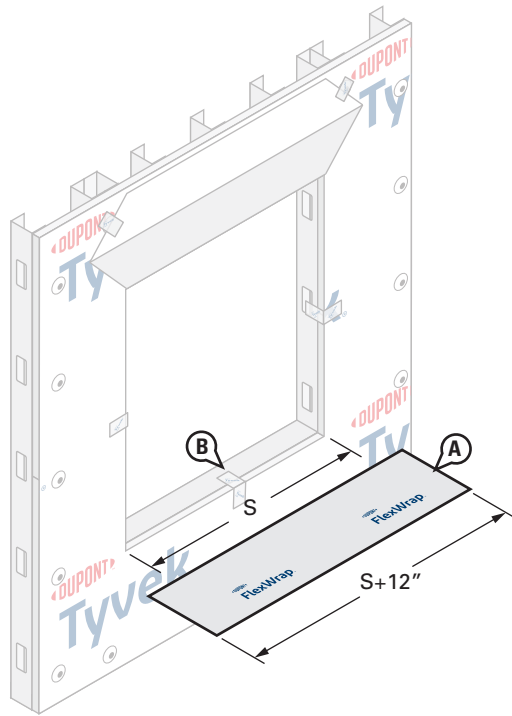

STEP 5

- A. Cut **DuPont™ FlexWrap™** at least 12” **LONGER** than the width of rough opening sill (S). Use roll widths sufficient to achieve a minimum of 1” adhesion **BEYOND** where the back of the window frame will be located, ensuring 2”– 3” adhesion onto the face of the wall.
- B. Inspect installation surface to ensure surface is free of dirt or substances that could interfere with adhesion as well as any sharp protrusions.

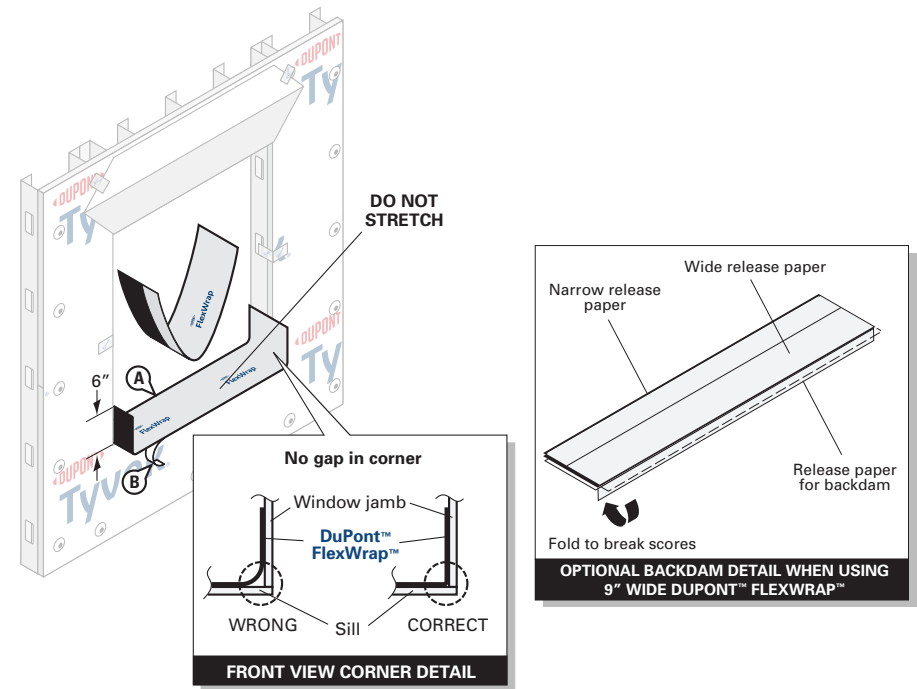

STEP 6

- A. Remove wide piece of release paper. Position on horizontal sill by aligning the inside edge of the narrow release paper with the face of the wall to ensure 2”– 3” of the **FlexWrap™** will be adhered to the **Tyvek® WRB** on the face of the wall with a minimum of 6” up each jamb. Adhere into rough opening.

Optional Back Dam: Fold 9” **FlexWrap™** to break perforation. Remove center piece of release paper. Cover horizontal sill to accommodate back dam as appropriate, and adhere into rough opening along sill and up jambs (min 6” on each side). Leave 1” release paper on **FlexWrap™** inside rough opening to finish back dam after window installation.

- B. Remove narrow release paper.

NOTE: DuPont™ Tyvek® Commercial Certified Installers may install a 3-piece head (and sill) detail for window openings less than 6 ft. wide. Installers who **are not** DuPont™ Tyvek® Commercial Certified Installers should refer to the [Special Considerations](#) section for more information regarding the 3-piece head/sill detail. Contact your local DuPont Building Envelope Specialist for more information about the Certified Installer program.

Installation Methods for DuPont Self-Adhered Flashing Products Installed **AFTER** the DuPont™ Tyvek® WRB Non-Flanged Windows and Doors (Using “Wrap the Cavity” Method)

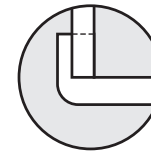
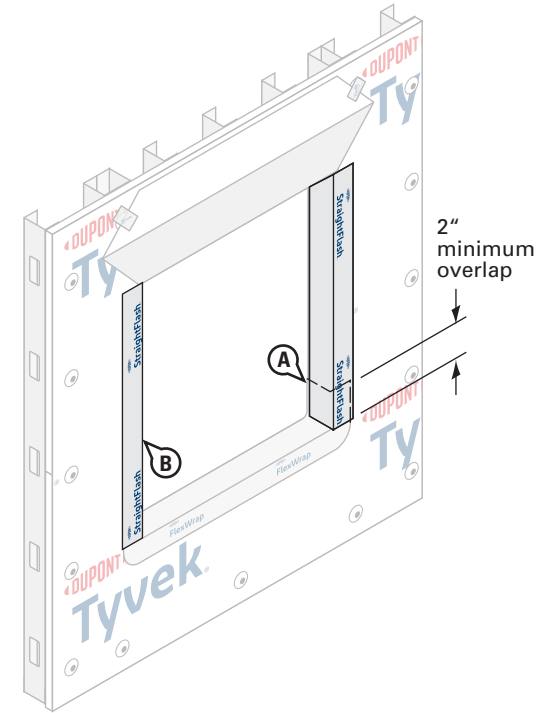
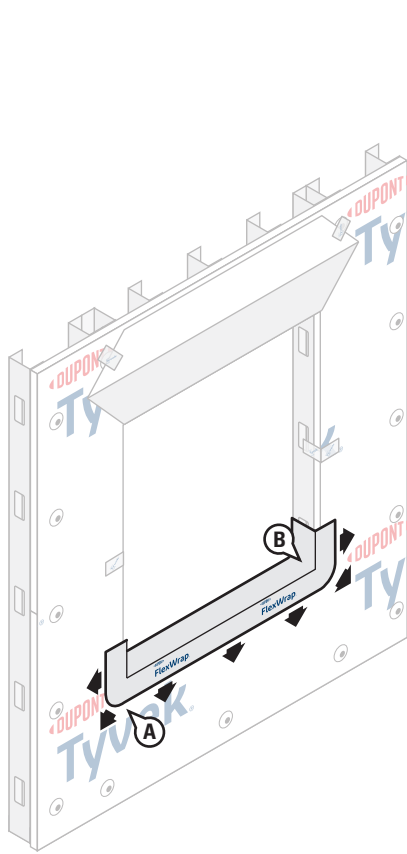

INCORRECT
DuPont™ FlexWrap™
reverse flashed

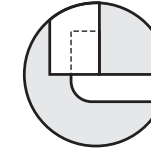

CORRECT
DuPont™ StraightFlash™
overlaps FlexWrap™

STEP 7

- Fan out the **DuPont™ FlexWrap™** at corners and adhere onto face of wall. Continue adhering onto face of wall along sill.
- Firmly press sill flashing to ensure full adhesion on all surfaces. Eliminate wrinkles and bubbles by smoothing surface and repositioning as necessary.

STEP 8

- Cut 9" **DuPont™ StraightFlash™** the vertical length of the rough opening. Jamb flashing should be long enough to overlap the sill flashing by at least 2" and be overlapped by future head flashing by at least 2".
- Wrap the **StraightFlash™** into the rough opening at each jamb and onto wall face. As a general reference, the flashing should align with the interior edge of the jamb framing.

Installation Methods for DuPont Self-Adhered Flashing Products Installed **AFTER** the DuPont™ Tyvek® WRB Non-Flanged Windows and Doors (Using “Wrap the Cavity” Method)

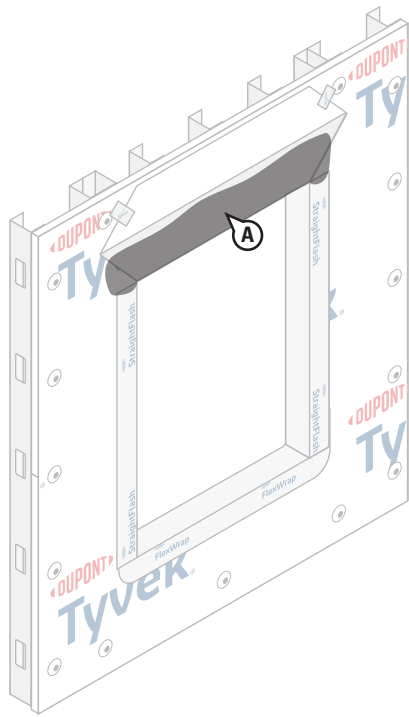

STEP 9

- A. Apply a recommended adhesive/primer to the top of the jambs and exposed sheathing. Refer to [Chemical Compatibility of Representative Building Sealants and Adhesives/Primers](#) for more information on recommended adhesives/primers.

Installation Methods for DuPont Self-Adhered Flashing Products Installed **AFTER** the DuPont™ Tyvek® WRB Non-Flanged Windows and Doors (Using “Wrap the Cavity” Method)

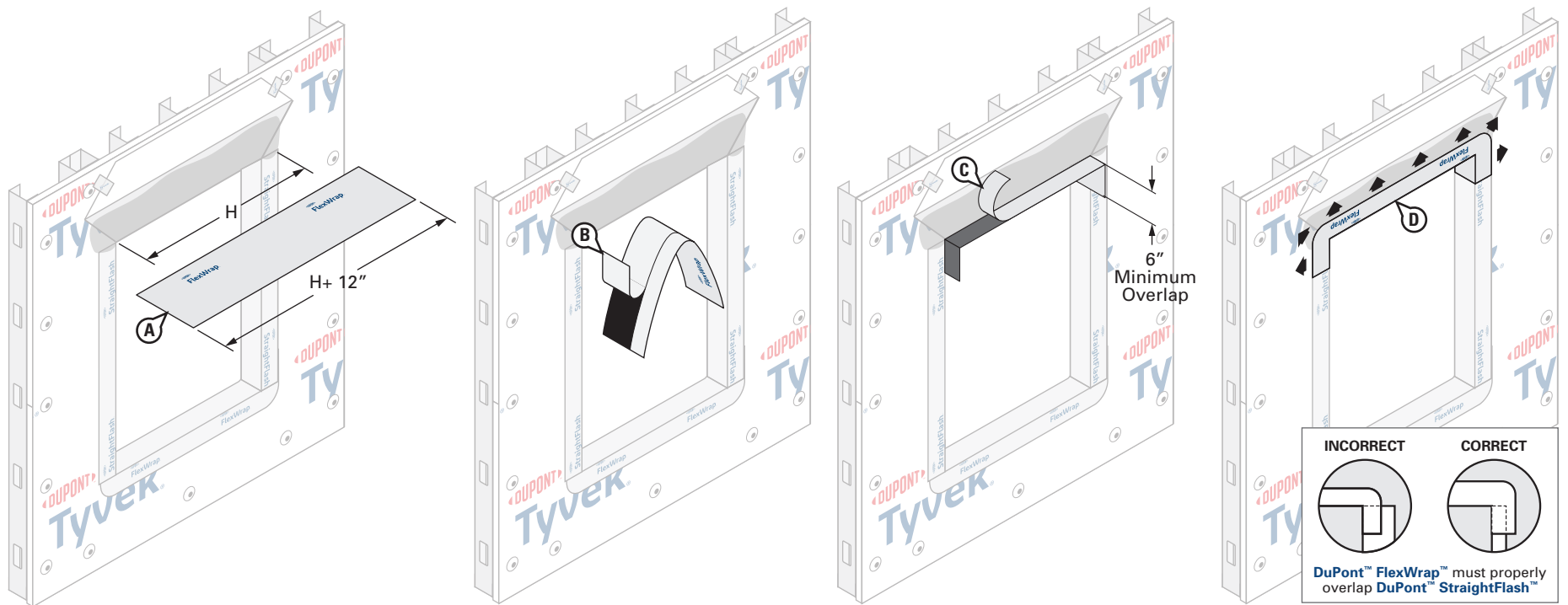

STEP 10

Install DuPont™ FlexWrap™ at Head

- Cut **FlexWrap™** at least 12" **LONGER** than the width of rough opening head (H). Use roll widths sufficient to achieve a minimum of 1" adhesion **BEYOND** where the back of the window frame will be located, ensuring 2"– 3" adhesion onto the face of the wall.
- Fold the **FlexWrap™** in half lengthwise to create a slight crease at the center. Remove the wide piece of release paper on one side of the fold. Align the inside edge of the narrow release paper with the face of the wall to ensure 2"– 3" of the **FlexWrap™** will be adhered to the face of the wall. Starting at the crease, adhere the **FlexWrap™** at the center of the horizontal portion of the head framing to ensure a minimum of 6" down each jamb. Adhere into rough opening at one corner and down the jamb. Remove the remaining release paper, and repeat at opposite corner.
- Remove narrow release paper.
- Fan out the **FlexWrap™** at corners and adhere onto face of wall. Continue adhering onto face of wall along the head.

NOTE: DuPont™ Tyvek® Commercial Certified Installers may install a 3-piece head (and sill) detail for window openings less than 6 ft. wide. Installers who **are not** DuPont™ Tyvek® Commercial Certified Installers should refer to the [Special Considerations](#) section for more information regarding the 3-piece head/sill detail. Contact your local DuPont Building Envelope Specialist for more information about the Certified Installer program.

Installation Methods for DuPont Self-Adhered Flashing Products Installed **AFTER** the DuPont™ Tyvek® WRB Non-Flanged Windows and Doors (Using “Wrap the Cavity” Method)

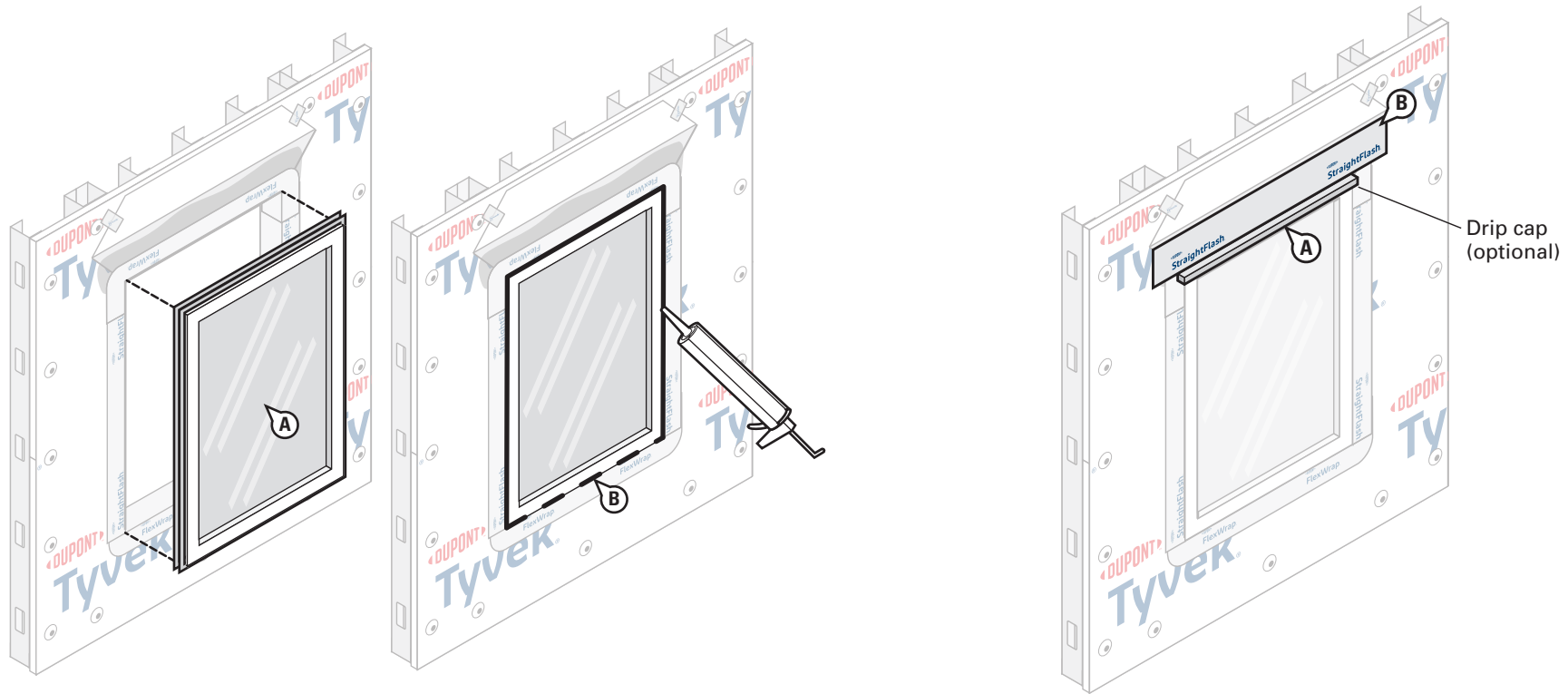

STEP 11

- A. Install window per manufacturer's installation instructions.
- B. Apply an exterior perimeter seal using backer rod and recommended sealant along the jambs and head of the window opening. Refer to [Chemical Compatibility of Representative Building Sealants and Adhesives/Primers](#) for more information on recommended sealants.

NOTE: Ensure window and sealant installation allows for drainage at the sill. If sealant is applied at the sill, as a best practice, ensure that there are at least two (2) 2" gaps in the sealant bead for every 4" of window to allow for drainage.

STEP 12 – OPTIONAL

- A. As a best practice for high exposure areas, install metal drip cap above the head joint when specified.
- B. Apply a strip of 4" **DuPont™ StraightFlash™** over the drip cap.

Installation Methods for DuPont Self-Adhered Flashing Products Installed AFTER the DuPont™ Tyvek® WRB Non-Flanged Windows and Doors (Using “Wrap the Cavity” Method)

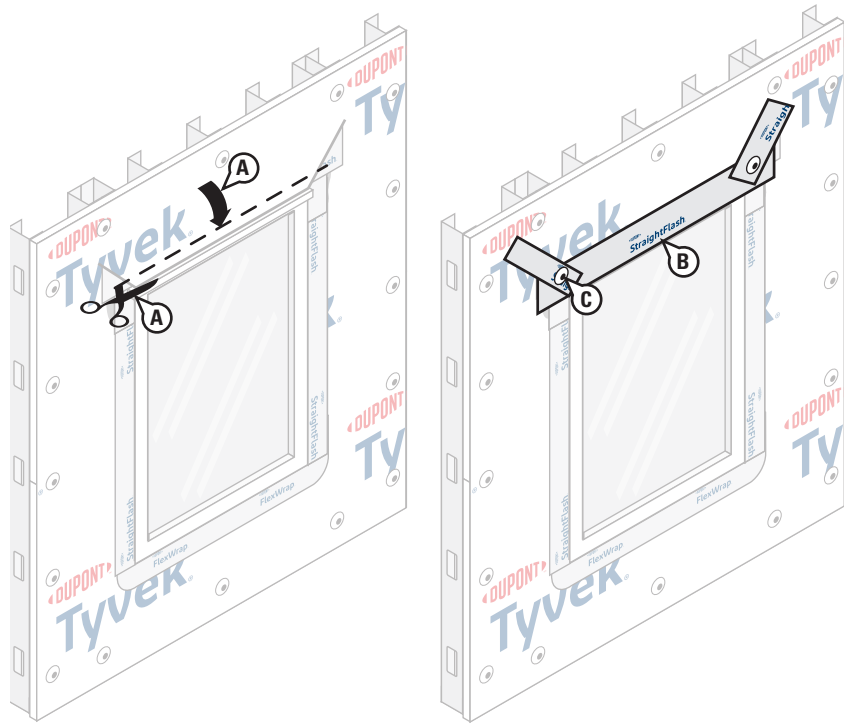

STEP 13

- Flip down the head flap and **trim 1”– 2” above the window opening**.
- Starting along the horizontal, terminate the head flap with 4” **DuPont™ StraightFlash™**. (See [Special Considerations](#) for allowances for using 4” **DuPont™ Flashing Tape** or 3” **Tyvek® Tape** in lieu of **StraightFlash™**).
- Install **DuPont™ Tyvek® Wrap Cap Fasteners** or recommended fasteners at appropriate spacing at head.

NOTE: For a more robust install, areas with extreme wind load exposures, or high performance testing use 4” **StraightFlash™** to seal the head flap and install additional mechanical fasteners through the flashing at the head flap and perimeter of window.

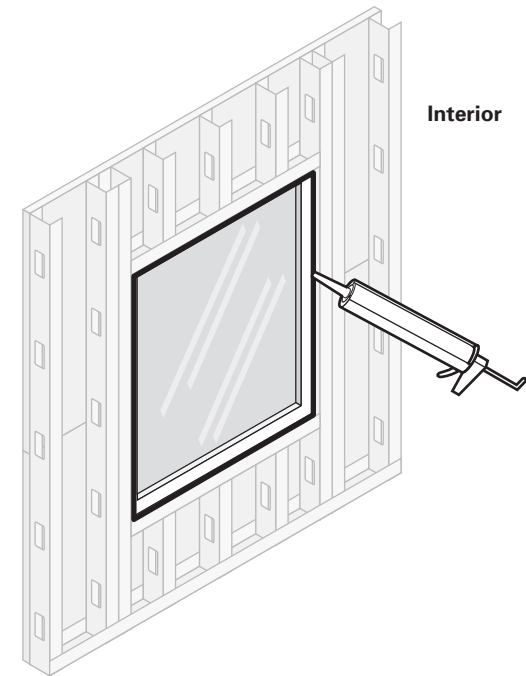

STEP 14

Final Step

Create a continuous perimeter seal using backer rod and recommended sealant or **Great Stuff Pro™ Window and Door Polyurethane Foam Sealant** on window interior to resist air and water infiltration. When using **Great Stuff Pro™ Window and Door Polyurethane Foam Sealant** in perimeter openings less than 1/2”, apply using the plastic extension tip for the **Great Stuff Pro™ Dispenser Gun** during installation.

NOTE: For high performance installations exceeding ASTM E1677 wind loading pressures (10.8 psf, 65 mph equivalent structural load) and ASTM E331 water infiltration resistance of 6.24 psf, it is necessary to install sealant over the cured foam when using **Great Stuff Pro™ Window and Door Polyurethane Foam Sealant** or other recommended foam. Sealant should be installed over the foam between the window frame and rough opening around the entire interior perimeter. If **Great Stuff Pro™ Window and Door Polyurethane Foam Sealant** or other recommended foam extends **BEYOND** the window frame, shave the excess cured foam flush with the window frame before applying sealant. Avoid damaging the **DuPont Self-Adhered Flashing Product**.

Installation Methods for DuPont Self-Adhered Flashing Products Installed **AFTER** the DuPont™ Tyvek® WRB Non-Flanged Window with Floating Lintel and Brick Facade

This method applies to the following products: DuPont™ StraightFlash™ and DuPont™ FlexWrap™

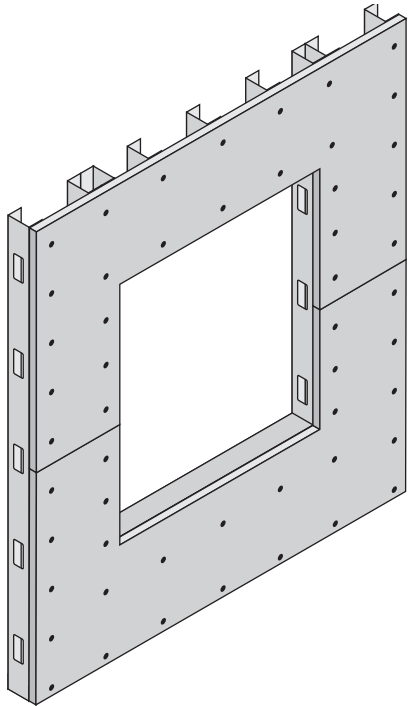

STEP 1

A. Cut rough opening in sheathing for window. Ensure that sheathing is cut flush with, or slightly below the sill framing to allow for positive drainage.

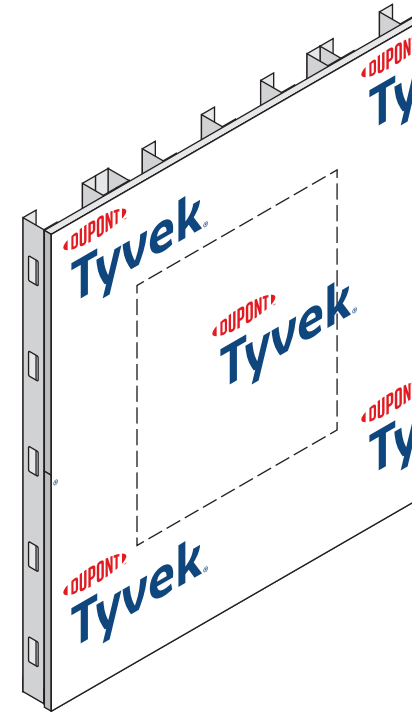

STEP 2

A. Wrap wall as shown in the [DuPont™ Tyvek® WRB Installation Instructions](#) section in this guide. Do not install fasteners within 6" of the sills and jambs of the openings and within 9" of the head of the openings.

Installation Methods for DuPont Self-Adhered Flashing Products Installed **AFTER** the DuPont™ Tyvek® WRB Non-Flanged Window with Floating Lintel and Brick Facade

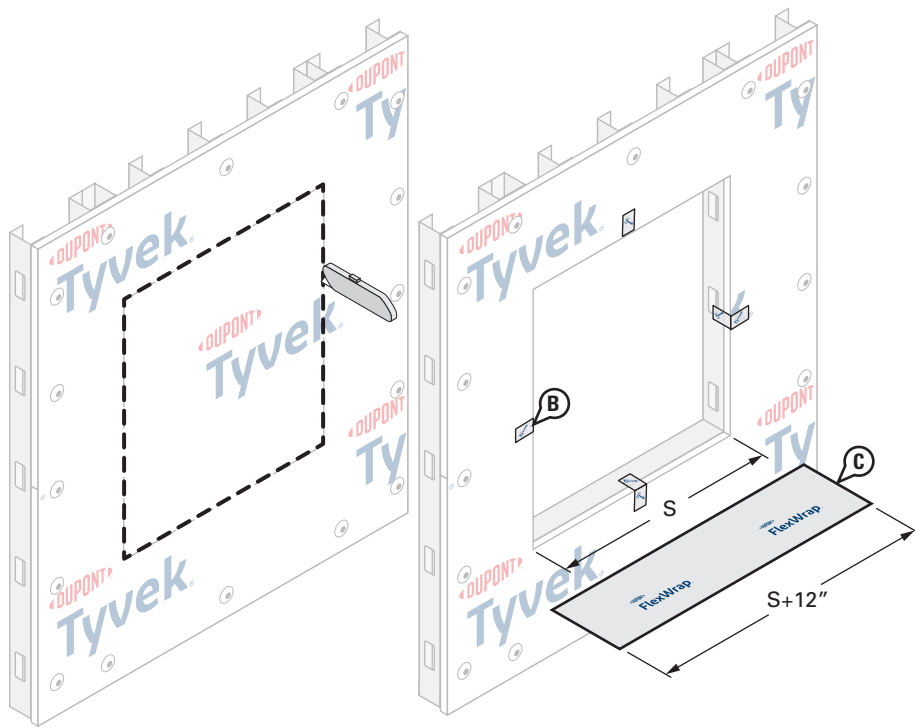

STEP 3

- Cut an opening in the **DuPont™ Tyvek® WRB** using a flush cut (“O-Cut”) along the perimeter of the opening.
- Temporarily secure **Tyvek® WRB** with **DuPont™ Tyvek® Tape** around rough opening before flashing is installed to help facilitate flashing installation.
- Cut **DuPont™ FlexWrap™** at least 12” **LONGER** than the width of rough opening sill. Use roll widths sufficient to achieve a minimum of 1” adhesion **BEYOND** where the back of the window frame will be located, ensuring 2”– 3” adhesion onto the face of the wall.
- Inspect installation surface to ensure surface is free of dirt or substances that could interfere with adhesion as well as any sharp protrusions.

NOTE: DuPont™ Tyvek® Commercial Certified Installers may install a 3-piece head (and sill) detail for window openings less than 6 ft. wide. Installers who **are not** DuPont™ Tyvek® Commercial Certified Installers should refer to the [Special Considerations](#) section for more information regarding the 3-piece head/sill detail. Contact your local DuPont Building Envelope Specialist for more information about the Certified Installer program.

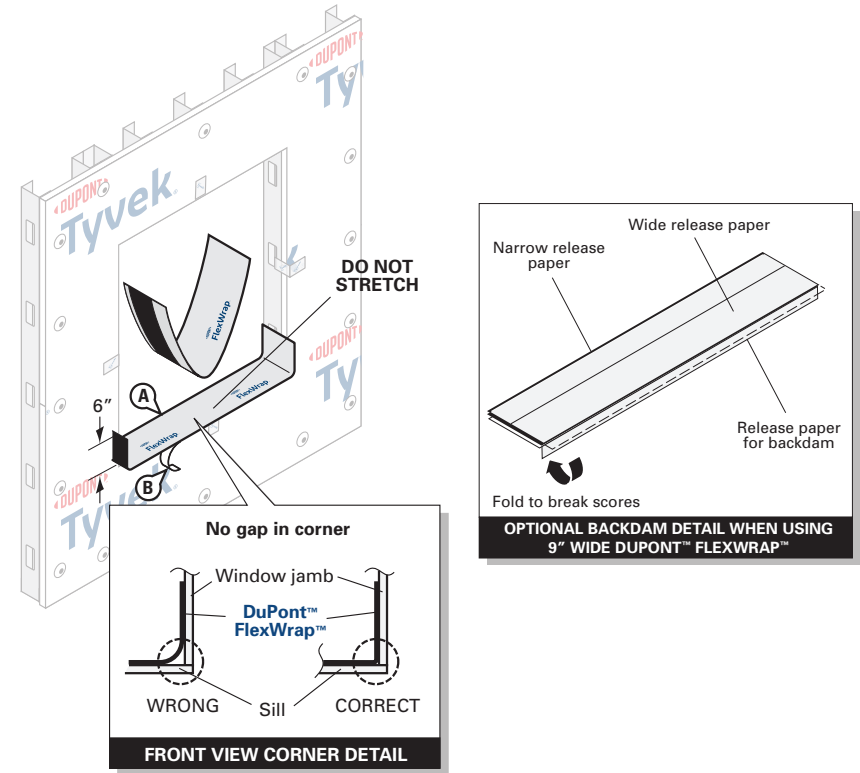

STEP 4

- Remove wide piece of release paper. Position on horizontal sill by aligning the inside edge of the narrow release paper with the face of the wall to ensure 2”– 3” of the **FlexWrap™** will be adhered to the face of the wall with a minimum of 6” up each jamb. Adhere into rough opening.
- Optional Back Dam:** Fold 9” **FlexWrap™** to break perforation. Remove center piece of release paper. Cover horizontal sill to accommodate back dam as appropriate, and adhere into rough opening along sill and up jambs (min 6” on each side). Leave 1” release paper on **FlexWrap™** inside rough opening to finish back dam after window installation.
 - Remove narrow release paper.

Installation Methods for DuPont Self-Adhered Flashing Products Installed **AFTER** the DuPont™ Tyvek® WRB Non-Flanged Window with Floating Lintel and Brick Facade

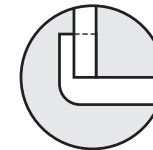
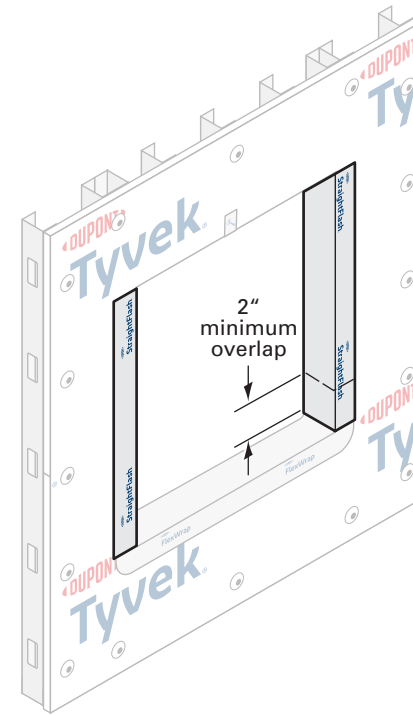
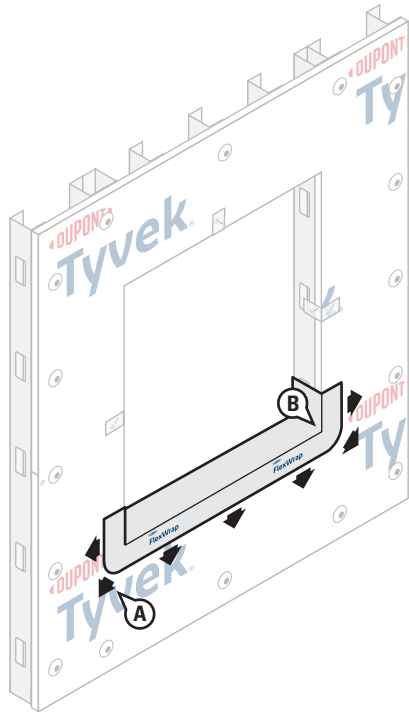

INCORRECT
DuPont™ FlexWrap™
reverse flashed

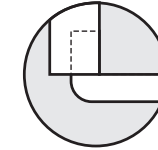

CORRECT
DuPont™ StraightFlash™
overlaps FlexWrap™

STEP 5

- A. Fan out the **DuPont™ FlexWrap™** at corners and adhere onto face of wall. Continue adhering onto face of wall along sill.
- B. Firmly press sill flashing to ensure full adhesion on all surfaces. Eliminate wrinkles and bubbles by smoothing surface.

STEP 6

- A. Cut 9" **DuPont™ StraightFlash™** the vertical length of the rough opening. Jamb flashing should be long enough to overlap the sill flashing by at least 2" and be overlapped by future head flashing by at least 2". Use roll widths sufficient to achieve a minimum of 1" adhesion **BEYOND** where the back of the window frame will be located, ensuring 2"- 3" adhesion onto the face of the wall.
- B. Wrap the **StraightFlash™** into the rough opening at each jamb and onto wall face. The flashing should align with the interior edge of the jamb framing.

Installation Methods for DuPont Self-Adhered Flashing Products Installed AFTER the DuPont™ Tyvek® WRB Non-Flanged Window with Floating Lintel and Brick Facade

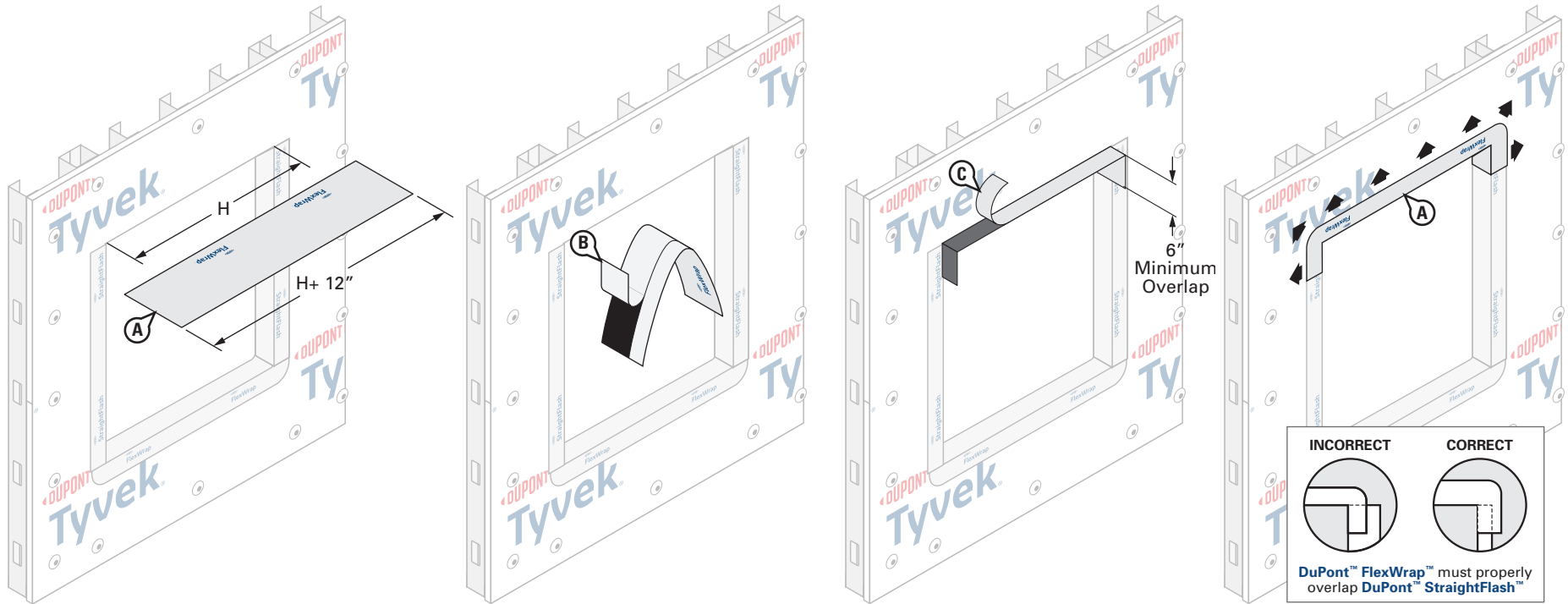

STEP 7

Install DuPont™ FlexWrap™ at Head

- A. Cut **FlexWrap™** at least 12" **LONGER** than the width of rough opening head (H). Use roll widths sufficient to achieve a minimum of 1" adhesion **BEYOND** where the back of the window frame will be located, ensuring 2"– 3" adhesion onto the face of the wall.
- B. Fold the **FlexWrap™** in half lengthwise to create a slight crease at the center. Remove the wide piece of release paper on one side of the fold. Align the inside edge of the narrow release paper with the face of the wall to ensure 2"– 3" of the **FlexWrap™** will be adhered to the face of the wall. Starting at the crease, adhere the **FlexWrap™** at the center of the horizontal portion of the head framing to ensure a minimum of 6" down each jamb. Adhere into rough opening at one corner and down the jamb. Remove the remaining release paper, and repeat at opposite corner.
- C. Remove narrow release paper.
- D. Fan out the **FlexWrap™** at corners and adhere onto face of wall. Continue adhering onto face of wall along the head.

NOTE: DuPont™ Tyvek® Commercial Certified Installers may install a 3-piece head (and sill) detail for window openings less than 6 ft. wide. Installers who **are not** DuPont™ Tyvek® Commercial Certified Installers should refer to the [Special Considerations](#) section for more information regarding the 3-piece head/sill detail. Contact your local DuPont Building Envelope Specialist for more information about the Certified Installer program.

Installation Methods for DuPont Self-Adhered Flashing Products Installed **AFTER** the DuPont™ Tyvek® WRB Non-Flanged Window with Floating Lintel and Brick Facade

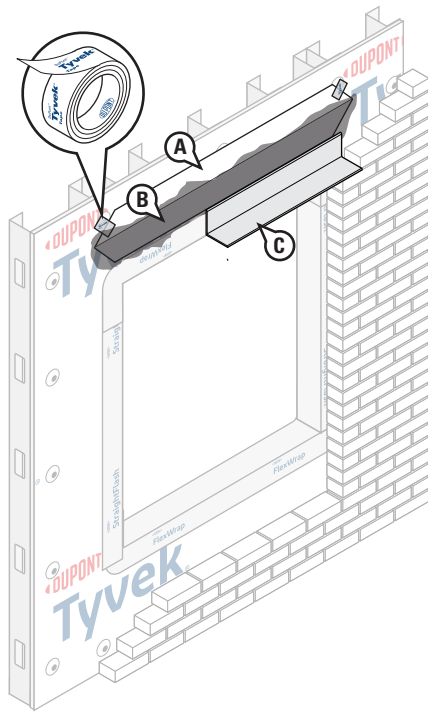

STEP 8

Install Floating Lintel

- A. Cut flap in the Tyvek® WRB.
- B. Apply a recommended adhesive/primer to exposed sheathing. Refer to [Chemical Compatibility of Representative Building Sealants and Adhesives/Primers](#) for more information on recommended adhesives/primers.
- C. Install lintel per plans and specifications.

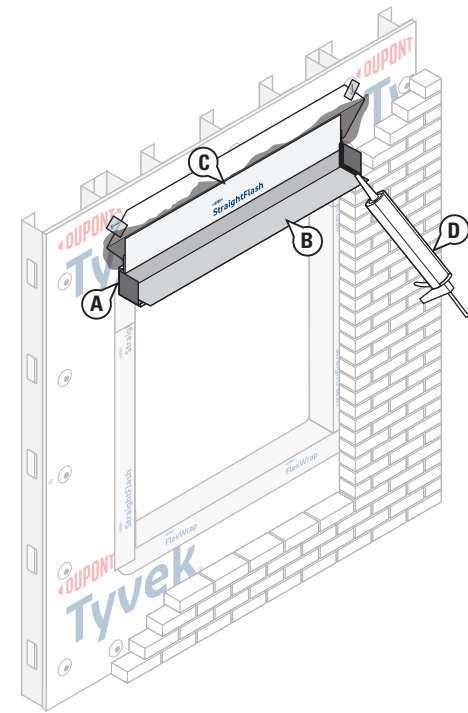

STEP 9

Head Detail Using Self-Adhered Through Wall Flashing

- A. Embed through wall flashing end dams in a recommended sealant and install along outer edge of lintel.
- B. Install recommended self-adhered through wall flashing with a minimum of 3" adhering to the wall sheathing, then overlapping the lintel. Extend the through wall flashing a minimum of 1/4" **BEYOND** the outside edge of the lintel to form a drip edge.
- C. **OPTIONAL:** Install 4" wide DuPont™ StraightFlash™ along the top edge of through wall flashing to achieve the 2" minimum contact to the exposed exterior sheathing.
- D. Apply recommended sealant along the edges of the through wall flashing.

Installation Methods for DuPont Self-Adhered Flashing Products Installed AFTER the DuPont™ Tyvek® WRB Non-Flanged Window with Floating Lintel and Brick Facade

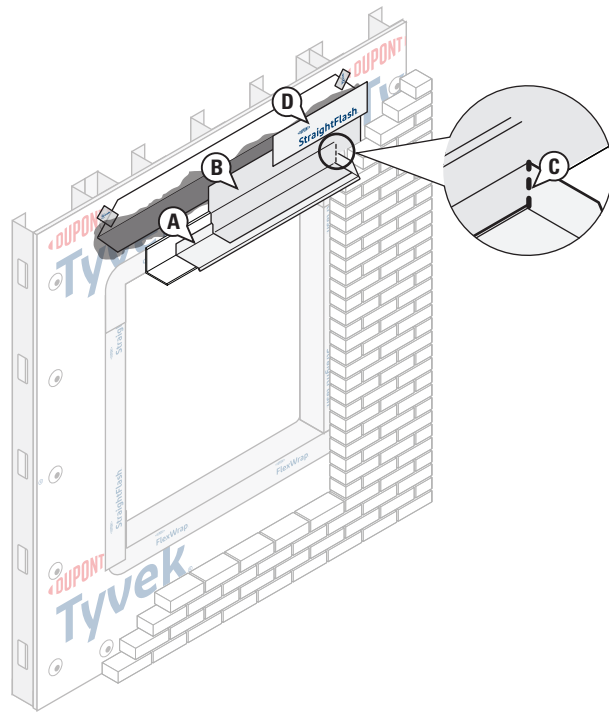

STEP 9 (ALTERNATE)

Head Detail Using Metal Pan and Mechanically-Attached Through Wall Flashing

- Install corrosion-resistant metal pan with drip and soldered/sealed end dams above lintel. The mechanical-fastened through wall flashing and drip should be embedded in sealant. Extend flashing **BEYOND** the end of lintel.
- Install through wall flashing a minimum of 3" onto the wall sheathing, overlapping the lintel, and extending onto the horizontal surface of the metal pan leaving minimum 1" of metal drip exposed.
- Cut a vertical slit in the through wall flashing to accommodate the vertical edge of the metal pan.
- Install 4" wide DuPont™ StraightFlash™ along the top edge of through wall flashing to achieve the 2" minimum contact to the exposed exterior sheathing.

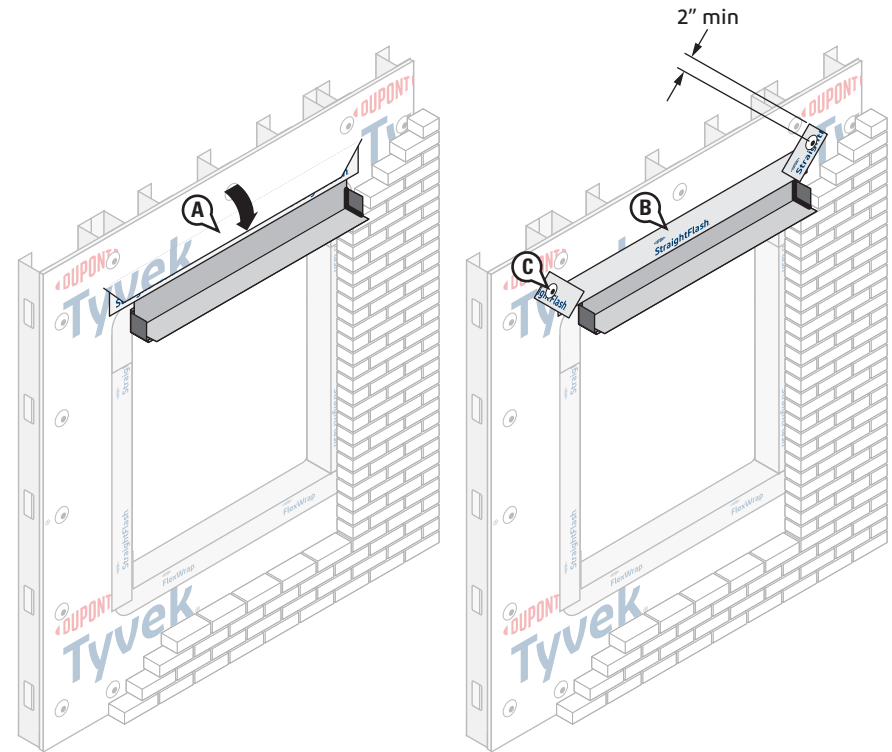

STEP 10

- Flip down the head flap. **NOTE:** If flap covers vertical leg of through wall flashing, trim **1"– 2"** above the horizontal leg to terminate head flap to vertical leg.
- Starting along the horizontal, terminate the head flap with 4" DuPont™ StraightFlash™. (See [Special Considerations](#) for allowances for using 4" DuPont™ Flashing Tape or 3" Tyvek® Tape in lieu of StraightFlash™).
- Install DuPont™ Tyvek® Wrap Cap Fasteners or recommended fasteners at appropriate spacing at head.

NOTE: For a more robust install, areas with extreme wind load exposures, or high performance testing use 4" StraightFlash™ to seal the head flap and install additional mechanical fasteners through the flashing at the head flap and perimeter of window.

Installation Methods for DuPont Self-Adhered Flashing Products Installed **AFTER** the DuPont™ Tyvek® WRB Non-Flanged Window with Floating Lintel and Brick Facade

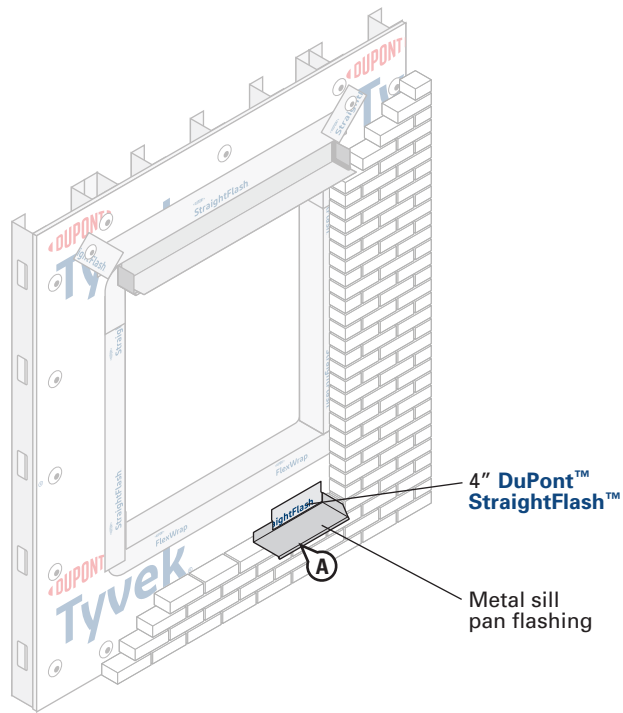

STEP 11

Install Metal Sill Pan

- A. Anchor the non-corrosive metal sill pan flashing to the wall and integrate to the Tyvek® WRB with 4" StraightFlash™.

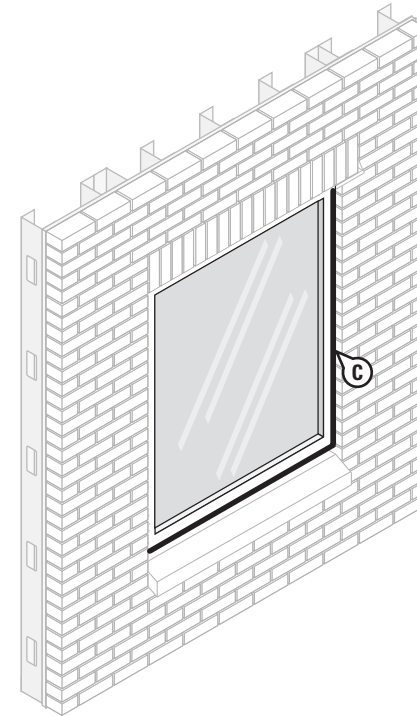

STEP 12

- A. Install remaining masonry with weeps along flashing.
B. Install window per manufacturer's instructions.
C. Seal all four sides of the perimeter of the window per project plans and specifications by others.

DO NOT SEAL ANY WEEPS OF WINDOW FRAME.

Installation Methods for DuPont Self-Adhered Flashing Products Installed AFTER the DuPont™ Tyvek® WRB Non-Flanged Window with Floating Lintel and Brick Facade

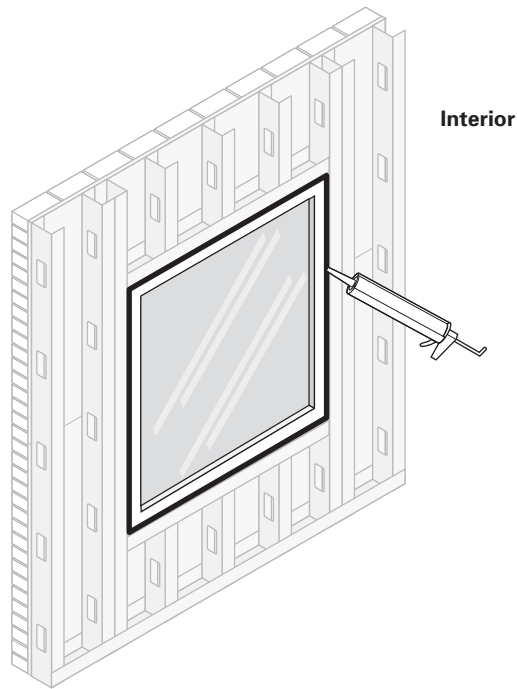

STEP 13

Final Step

Create a continuous perimeter seal using backer rod and recommended sealant or **Great Stuff Pro™ Window and Door Polyurethane Foam Sealant** on window interior to resist air and water infiltration. When using **Great Stuff Pro™ Window and Door Polyurethane Foam Sealant** in perimeter openings less than 1/2", apply using the plastic extension tip for the **Great Stuff Pro™ Dispenser Gun** during installation. Refer to [Chemical Compatibility of Representative Building Sealants and Adhesives/Primers](#) for more information on recommended sealants.

NOTE: For high performance installations exceeding ASTM E1677 wind loading pressures (10.8 psf, 65 mph equivalent structural load) and ASTM E331 water infiltration resistance of 6.24 psf, it is necessary to install sealant over the cured foam when using **Great Stuff Pro™ Window and Door Polyurethane Foam Sealant** or other recommended foam. Sealant should be installed over the foam between the window frame and rough opening around the entire interior perimeter. If **Great Stuff Pro™ Window and Door Polyurethane Foam Sealant** or other recommended foam extends **BEYOND** the window frame, shave the excess cured foam flush with the window frame before applying sealant. Avoid damaging the **DuPont Self-Adhered Flashing Product**.

Installation Methods for DuPont Self-Adhered Flashing Products Installed AFTER the DuPont™ Tyvek® WRB

Non-Flanged Window with Floating Lintel and Brick Facade

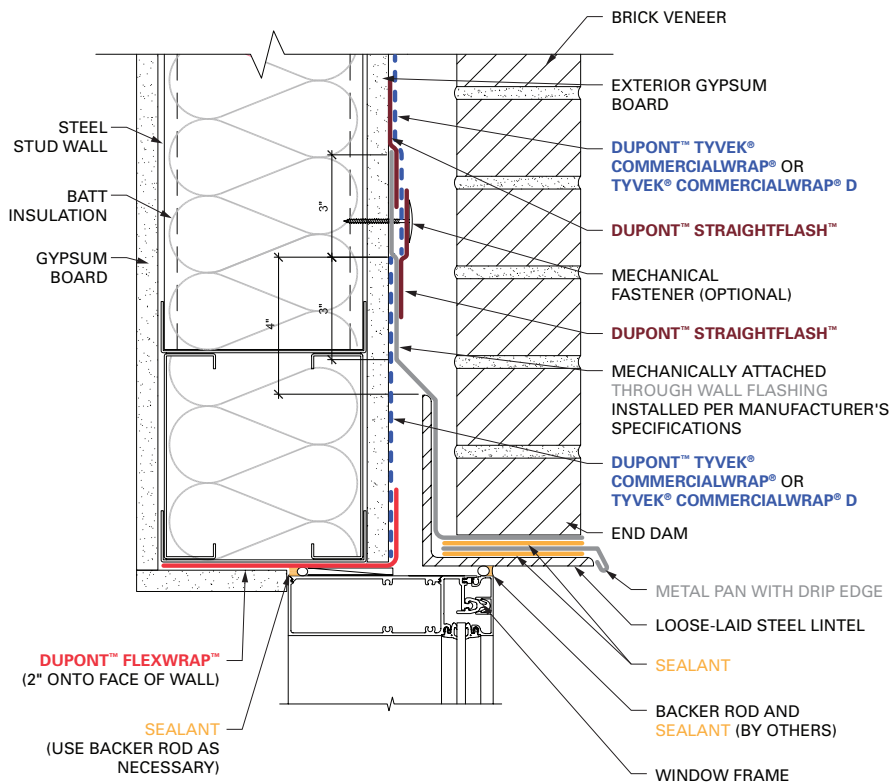

FLOATING LINTEL WITH METAL PAN AND MECHANICALLY ATTACHED THROUGH WALL FLASHING (SIDE VIEW)

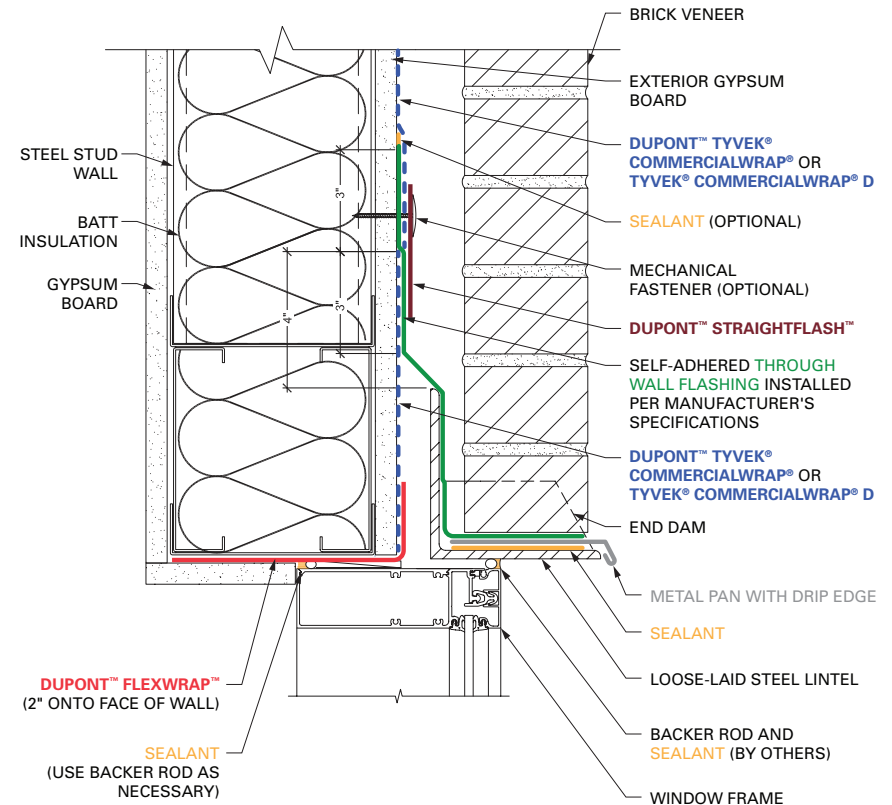

FLOATING LINTEL WITH SELF-ADHERED THROUGH WALL FLASHING (SIDE VIEW)

NOTE: CAD details not to scale. For additional CAD details, visit building.dupont.com

Installation Methods for DuPont Self-Adhered Flashing Products Installed AFTER the DuPont™ Tyvek® WRB

Non-Flanged Window with Floating Lintel and Brick Facade

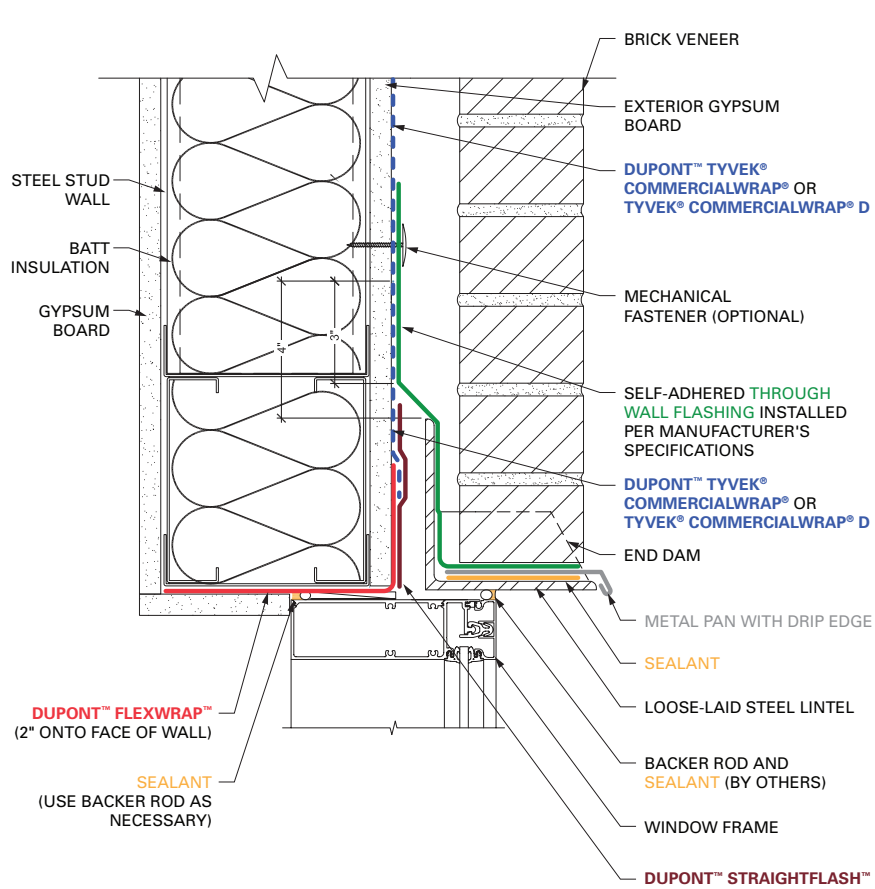

FLOATING LINTEL WITH THROUGH WALL FLASHING ADHERED TO DUPONT™ TYVEK® WRB (SIDE VIEW)

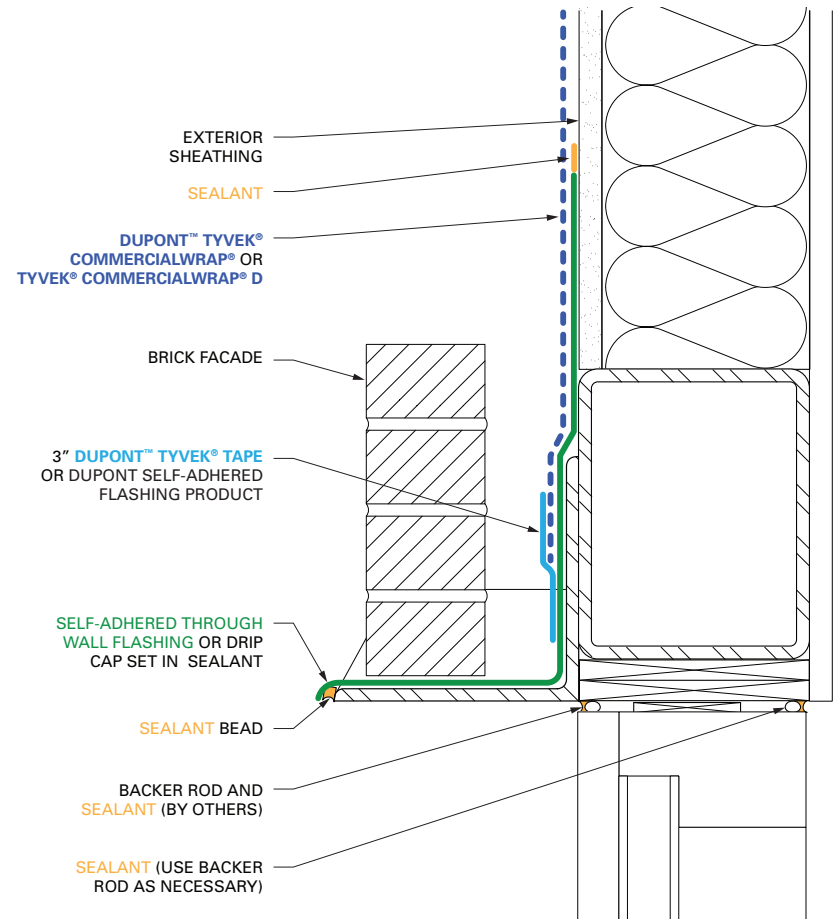

HEAD DETAIL FOR ATTACHED LINTEL WITH SELF-ADHERED THROUGH WALL FLASHING (SIDE VIEW)

NOTE: CAD details not to scale. For additional CAD details, visit building.dupont.com

Installation Methods for DuPont Self-Adhered Flashing Products Installed AFTER the DuPont™ Tyvek® WRB
Non-Flanged Window with Floating Lintel and Brick Facade

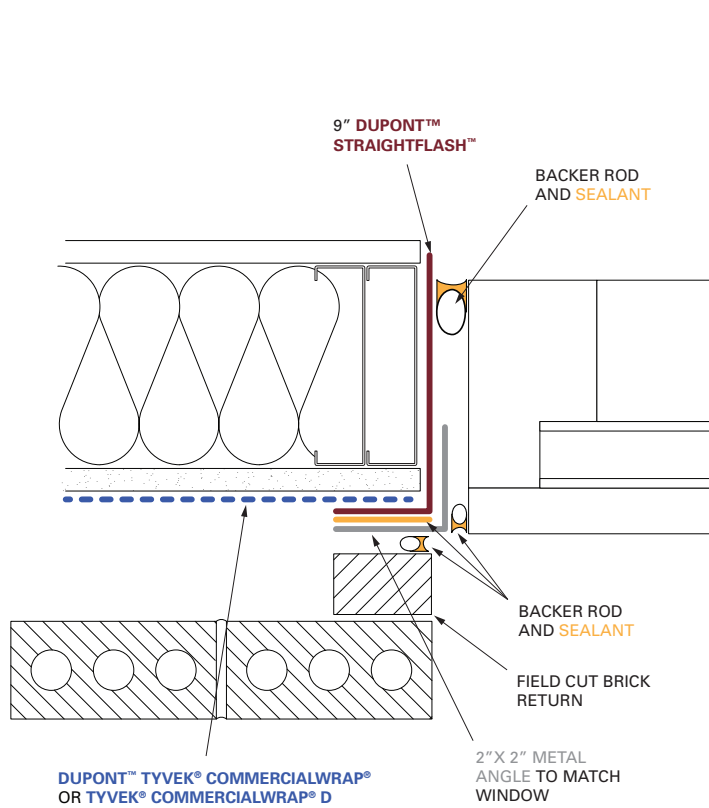

OPTIONAL JAMB DETAIL (TOP VIEW)

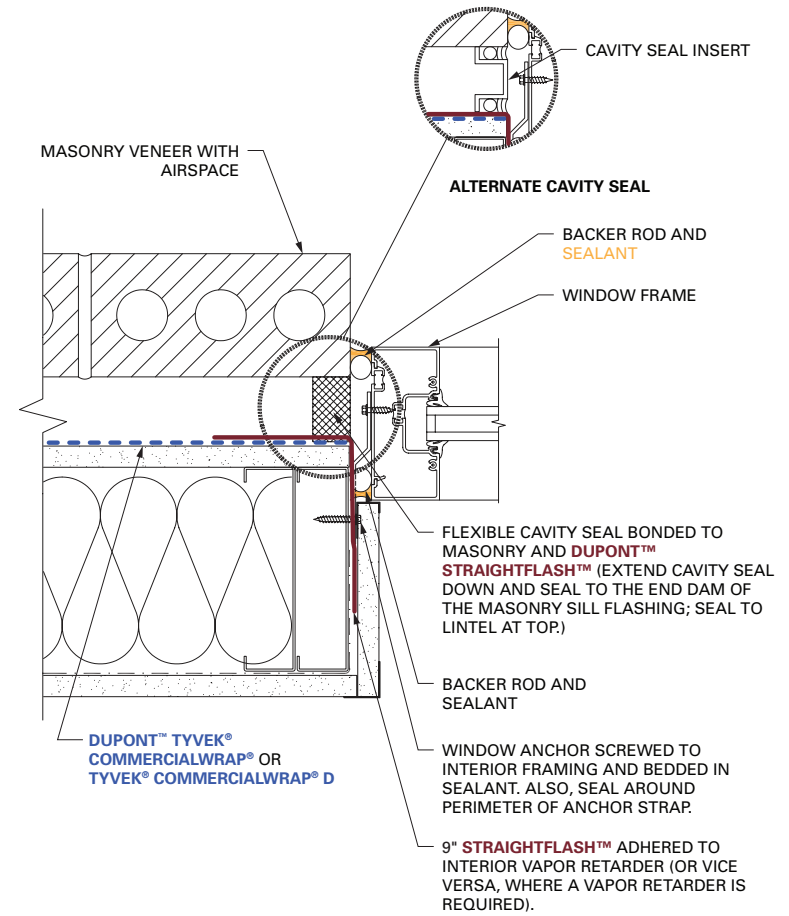

OPTIONAL JAMB DETAIL (TOP VIEW)

NOTE: CAD details not to scale. For additional CAD details, visit building.dupont.com

Installation Methods for DuPont Self-Adhered Flashing Products Installed AFTER the DuPont™ Tyvek® WRB

Non-Flanged Window with Floating Lintel and Brick Facade

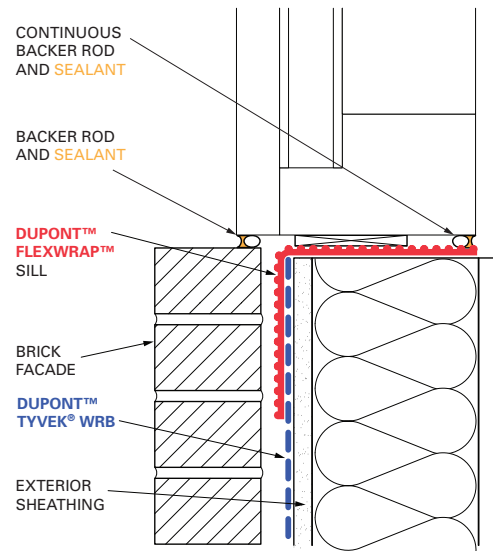

SILL DETAIL (SIDE VIEW)

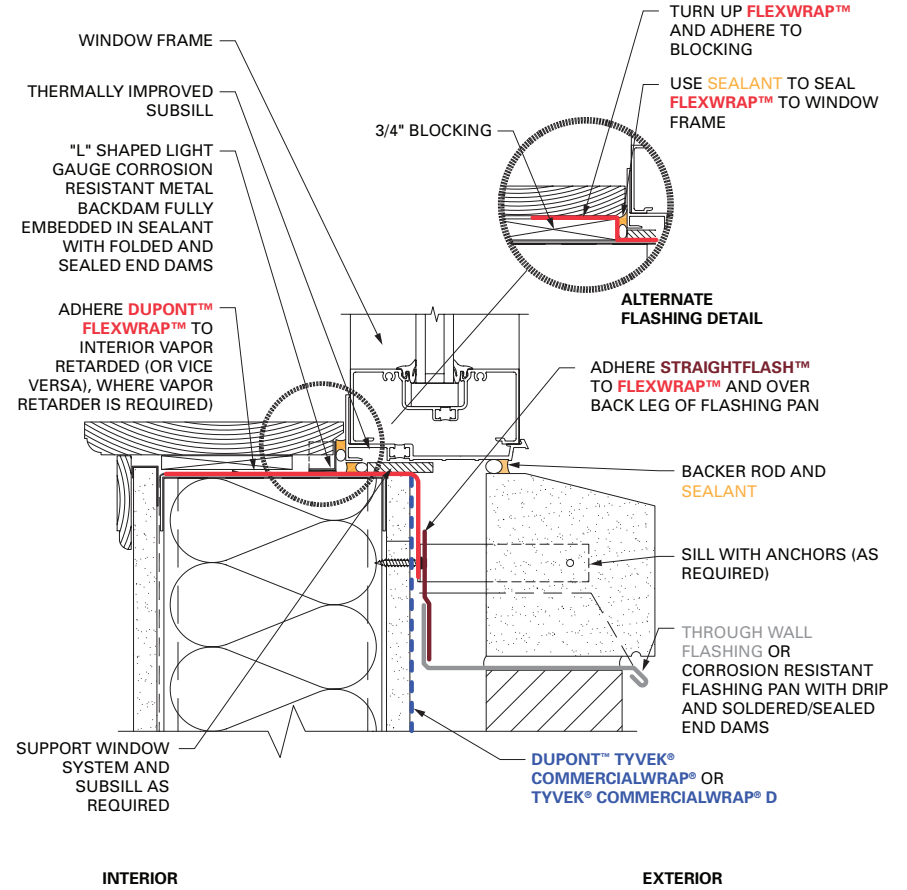

SILL DETAIL (SIDE VIEW) METAL THROUGH WALL FLASHING

NOTE: CAD details not to scale. For additional CAD details, visit building.dupont.com

Installation Methods for DuPont Self-Adhered Flashing Products Installed AFTER the DuPont™ Tyvek® WRB

Non-Flanged Door on Slab

This door detail can be used for any non-flanged door rough opening, including storefront or hollow metal doors. Use of this detail requires the ability to protect the rough opening at the jambs and head with **DuPont Self-Adhered Flashing**. For welded hollow metal doors or other welded-in-place doors where the rough opening cannot be protected, the **Tyvek® WRB** must be terminated on the face of the wall around the perimeter of the opening with **DuPont™ StraightFlash™**.

This method applies to the following products: **DuPont™ StraightFlash™** and **DuPont™ FlexWrap™**

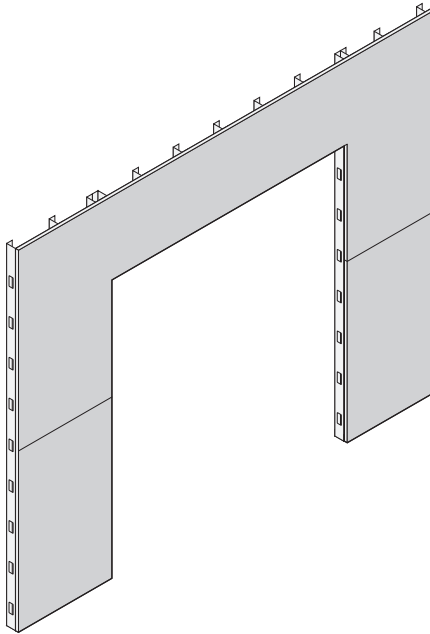

STEP 1

A. Cut rough opening in sheathing for door.

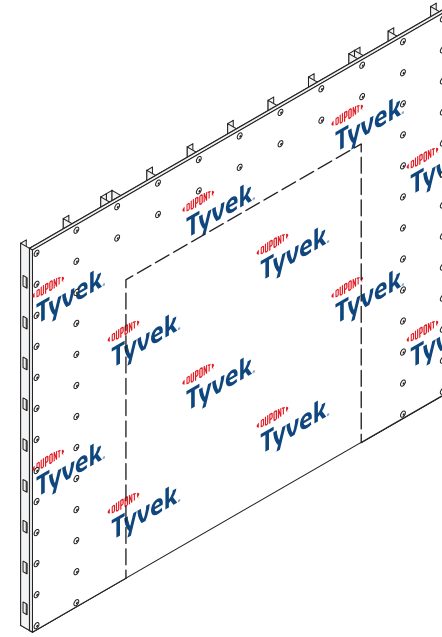

STEP 2

A. Wrap wall as shown in the [DuPont™ Tyvek® WRB Installation Instructions](#) section in this guide. Do not install fasteners within 6" of the jambs of the openings and within 9" of the head of the openings.

Installation Methods for DuPont Self-Adhered Flashing Products Installed AFTER the DuPont™ Tyvek® WRB Non-Flanged Door on Slab

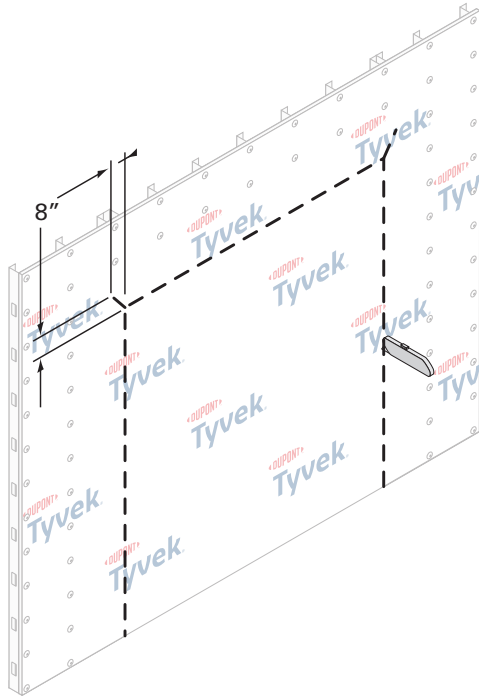

STEP 3

Prepare the **Tyvek® WRB** for door installation.

- Cut an opening in the **Tyvek® WRB** using a flush cut around the perimeter of the rough opening.
- Cuts should be made along the dashed indicated lines. (Ensure that the **Tyvek® WRB** is cut flush with the sheathing and is not wrapped into the rough opening.)
- Cut a head flap at a 45° angle to expose 8" of sheathing to allow for head flashing installation.

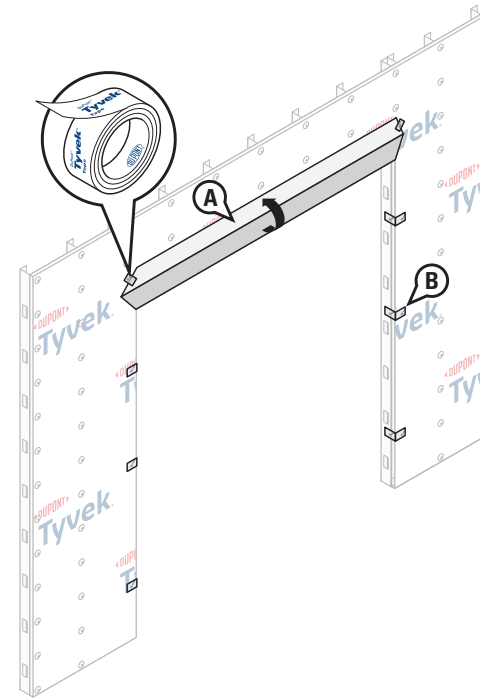

STEP 4

- Flip the head flap up to expose the sheathing and temporarily secure with tape.
- Temporarily secure **Tyvek® WRB** with **DuPont™ Tyvek® Tape** around rough opening before flashing is installed to help facilitate flashing installation.

Installation Methods for DuPont Self-Adhered Flashing Products Installed AFTER the DuPont™ Tyvek® WRB Non-Flanged Door on Slab

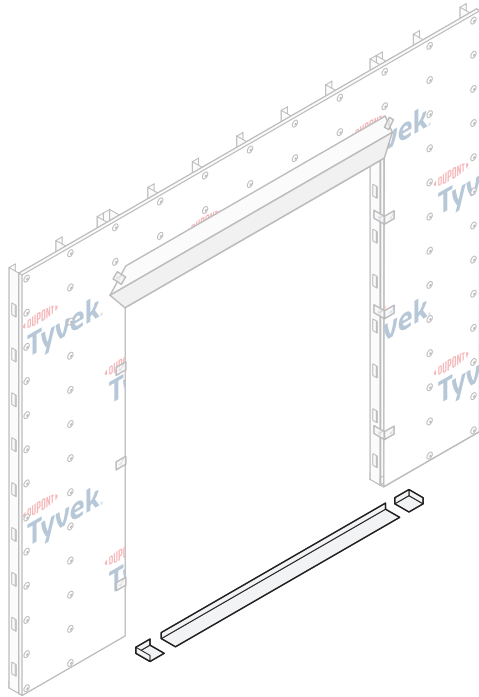

STEP 5

- A. Prepare the sill flashing and/or threshold per manufacturer's recommendation and seal the corner pan flashing with sealant if applicable.
- B. Inspect installation surface to ensure surface is free of dirt or substances that could interfere with adhesion as well as any sharp protrusions.

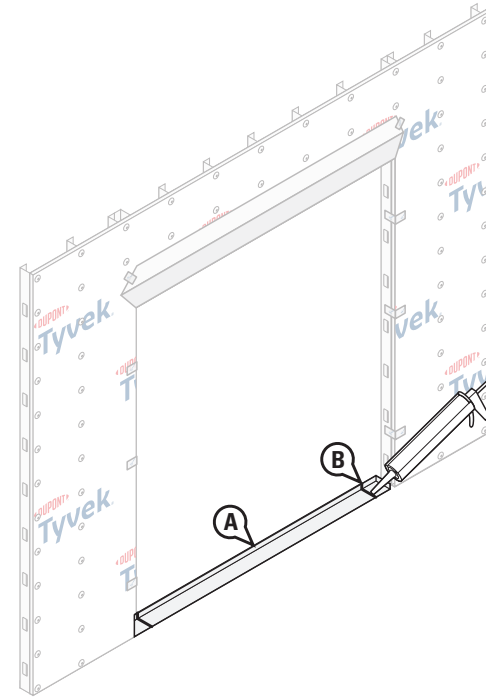

STEP 6

- A. Shim, level, and anchor pan/threshold per manufacturer's instructions flashing to concrete.
- B. Seal corner pan flashing seams with recommended sealant if applicable. Refer to [Chemical Compatibility of Representative Building Sealants and Adhesives/Primers](#) for more information on recommended sealants.

Installation Methods for DuPont Self-Adhered Flashing Products Installed AFTER the DuPont™ Tyvek® WRB Non-Flanged Door on Slab

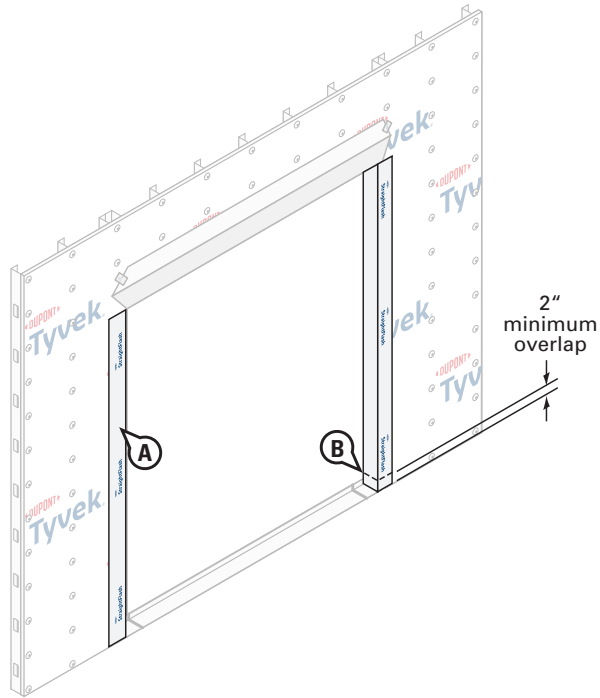

STEP 7

- A. Wrap 9" DuPont™ StraightFlash™ into the rough opening at each jamb and onto wall face. The flashing should align with the interior edge of the jamb framing. Cut the jamb flashing the vertical length of the rough opening.
- B. Jamb flashing should be long enough to overlap the sill flashing by at least 2" and be overlapped by future head flashing by at least 2".

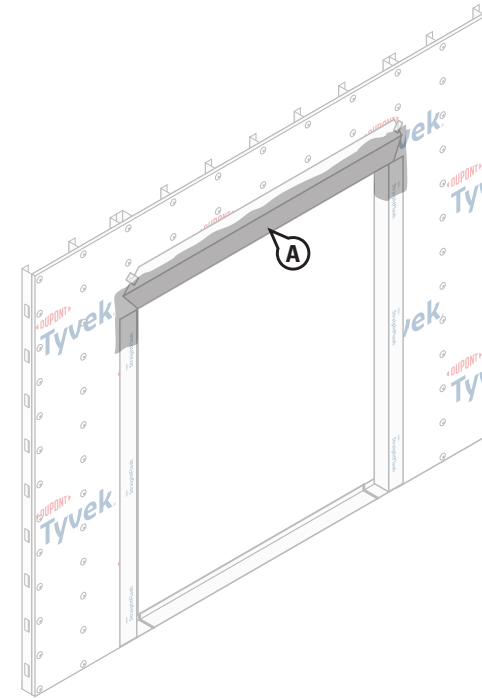

STEP 8

- A. Apply a recommended adhesive/primer to the top of the jambs and exposed sheathing. Refer to [Chemical Compatibility of Representative Building Sealants and Adhesives/Primers](#) for more information on recommended adhesives/primers.

Installation Methods for DuPont Self-Adhered Flashing Products Installed AFTER the DuPont™ Tyvek® WRB Non-Flanged Door on Slab

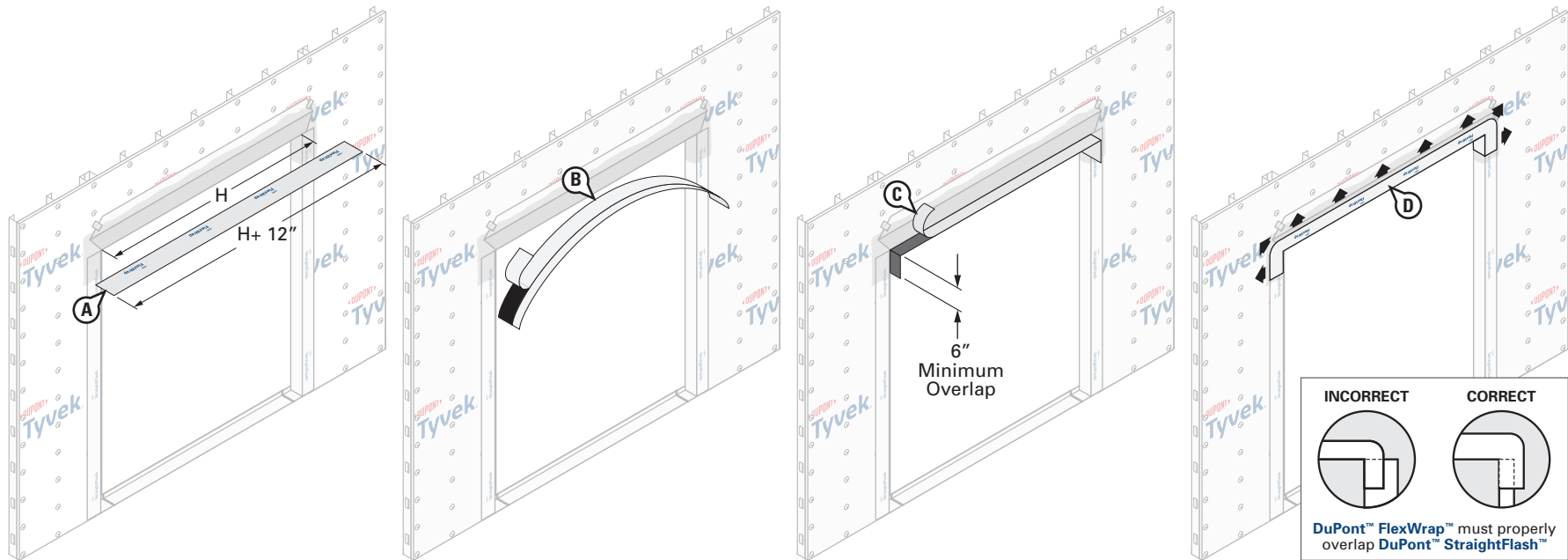

STEP 9

Install DuPont™ FlexWrap™ at Head

- A. Cut **FlexWrap™** at least 12" **LONGER** than the width of rough opening head (H). Use roll widths sufficient to achieve a minimum of 1" adhesion **BEYOND** where the back of the window frame will be located, ensuring 2"– 3" adhesion onto the face of the wall.
- B. Fold the **FlexWrap™** in half lengthwise to create a slight crease at the center. Remove the wide piece of release paper on one side of the fold. Align the inside edge of the narrow release paper with the face of the wall to ensure 2"– 3" of the **FlexWrap™** will be adhered to the face of the wall. Starting at the crease, adhere the **FlexWrap™** at the center of the horizontal portion of the head framing to ensure a minimum of 6" down each jamb. Adhere into rough opening at one corner and down the jamb. Remove the remaining release paper, and repeat at opposite corner.
- C. Remove narrow release paper.
- D. Fan out the **FlexWrap™** at corners and adhere onto face of wall. Continue adhering onto face of wall along the head.
- E. Use sufficient width of **FlexWrap™** to avoid reverse shingling of flashing at the jamb and head interface. See detail above.

NOTE: DuPont™ Tyvek® Commercial Certified Installers may install a 3-piece head (and sill) detail for window openings less than 6 ft. wide. Installers who **are not** DuPont™ Tyvek® Commercial Certified Installers should refer to the [Special Considerations](#) section for more information regarding the 3-piece head/sill detail. Contact your local DuPont Building Envelope Specialist for more information about the Certified Installer program.

Installation Methods for DuPont Self-Adhered Flashing Products Installed AFTER the DuPont™ Tyvek® WRB Non-Flanged Door on Slab

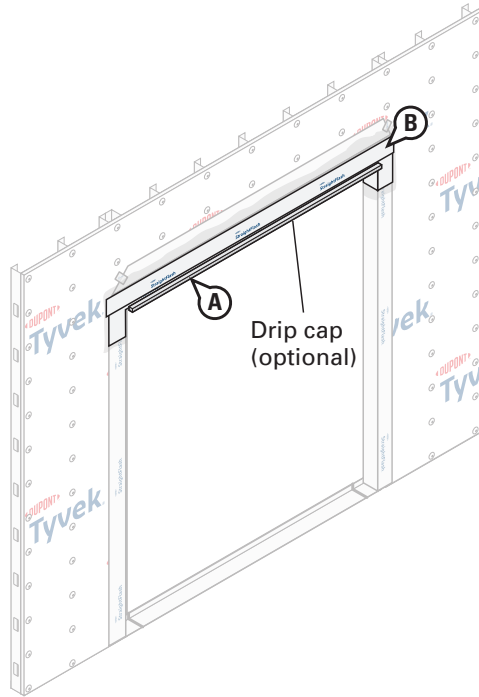

STEP 10 – OPTIONAL

- A. As a best practice for high exposure areas, install metal drip cap above the head joint when specified.
- B. Apply a strip of 4" **DuPont™ StraightFlash™** over the drip cap.

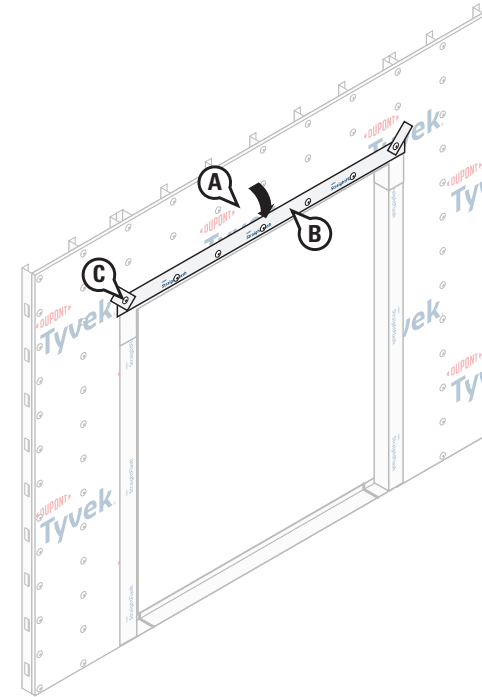

STEP 11

- A. Flip down the head flap and trim 1"-2" above the door opening.
- B. Starting along the horizontal, terminate the head flap with 4" **DuPont™ StraightFlash™**. (See [Special Considerations](#) for allowances for using 4" **DuPont™ StraightFlash™** or 3" **Tyvek® Tape** in lieu of **StraightFlash™**).
- C. Install **DuPont™ Tyvek® Wrap Cap Fasteners** or recommended fasteners at head according to the fastening schedule (every 12" to 18" depending on the vertical stud line).

NOTE: For a more robust install, areas with extreme wind load exposures, or high performance testing use 4" **StraightFlash™** to seal the head flap and install additional mechanical fasteners through the flashing at the head flap and perimeter of window.

Installation Methods for DuPont Self-Adhered Flashing Products Installed AFTER the DuPont™ Tyvek® WRB Non-Flanged Door on Slab

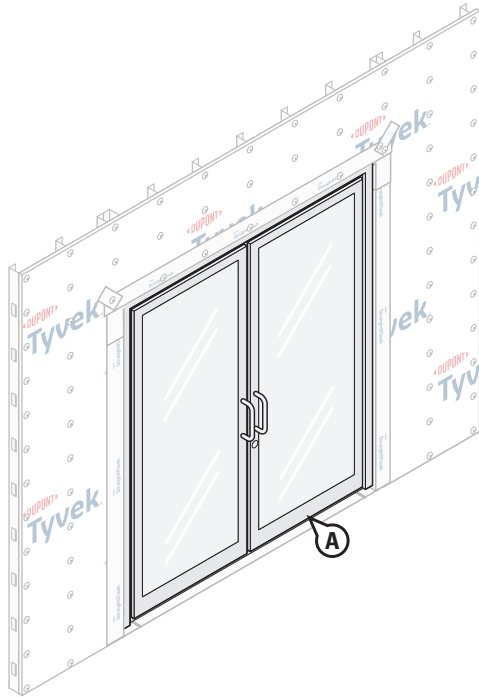

STEP 12

- A. Install door per manufacturer's installation instructions.
- B. If applicable, glaze door per manufacturer's instructions.

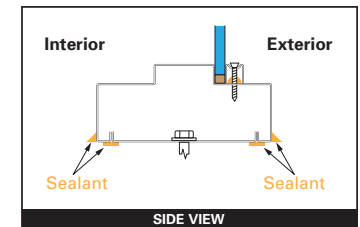
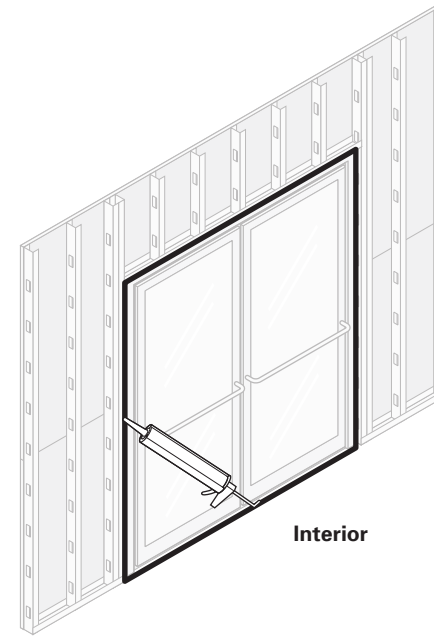

STEP 13

Final Step

Create a continuous perimeter seal using backer rod and recommended sealant or **Great Stuff Pro™ Window and Door Polyurethane Foam Sealant** on door interior to resist air and water infiltration. When using **Great Stuff Pro™ Window and Door Polyurethane Foam Sealant** in perimeter openings less than ½", apply using the plastic extension tip for the **Great Stuff Pro™ Dispenser Gun** during installation. Refer to [Chemical Compatibility of Representative Building Sealants and Adhesives/Primers](#) for more information on recommended sealants.

NOTE: For high performance installations exceeding ASTM E1677 wind loading pressures (10.8 psf, 65 mph equivalent structural load) and ASTM E331 water infiltration resistance of 6.24 psf, it is necessary to install sealant over the cured foam when using **Great Stuff Pro™ Window and Door Polyurethane Foam Sealant** or other recommended foam. Sealant should be installed over the foam between the door frame and rough opening around the entire interior perimeter. If **Great Stuff Pro™ Window and Door Polyurethane Foam Sealant** or other recommended foam extends **BEYOND** the door frame, shave the excess cured foam flush with the door frame before applying sealant. Avoid damaging the **DuPont Self-Adhered Flashing Product**.

Installation Methods for DuPont Self-Adhered Flashing Products Installed AFTER the DuPont™ Tyvek® WRB

Non-Flanged Door on Slab

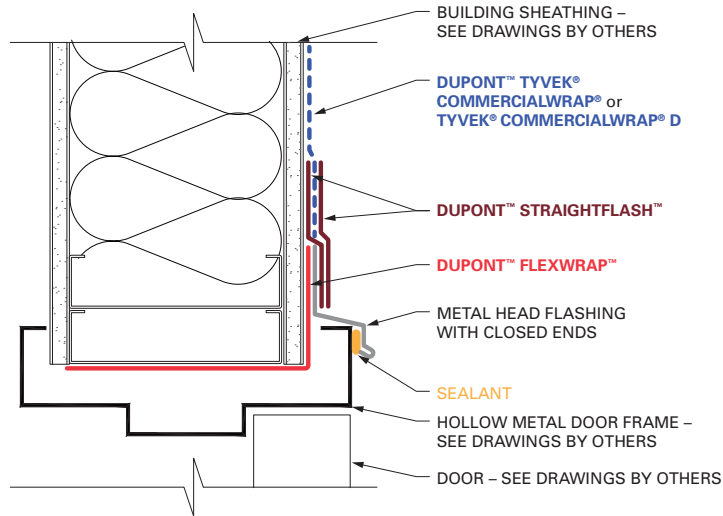

HEAD DETAIL (SIDE VIEW) – HOLLOW METAL DOOR

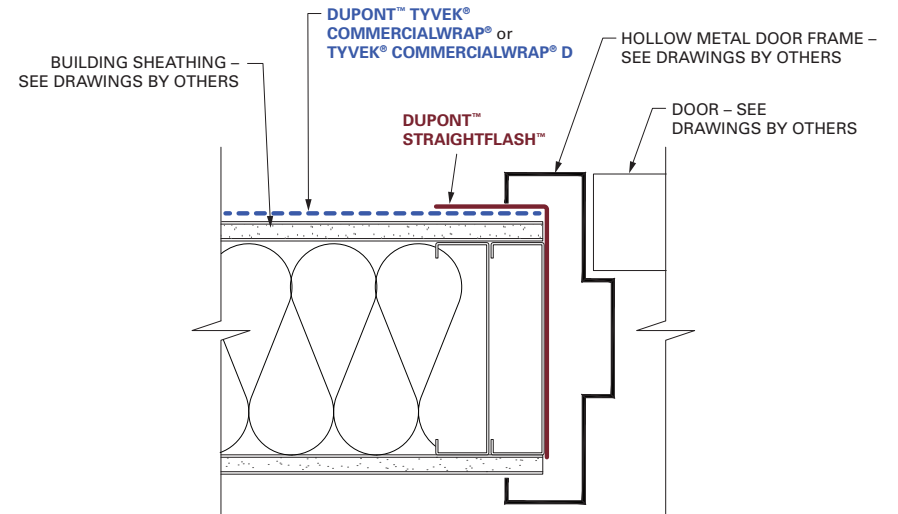

JAMB DETAIL (TOP VIEW) – HOLLOW METAL DOOR

NOTE: CAD details not to scale. For additional CAD details, visit building.dupont.com

Installation Methods for DuPont Self-Adhered Flashing Products Installed **AFTER** the DuPont™ Tyvek® WRB Storefront Window on Slab

This method applies to the following products: DuPont™ StraightFlash™ and DuPont™ FlexWrap™

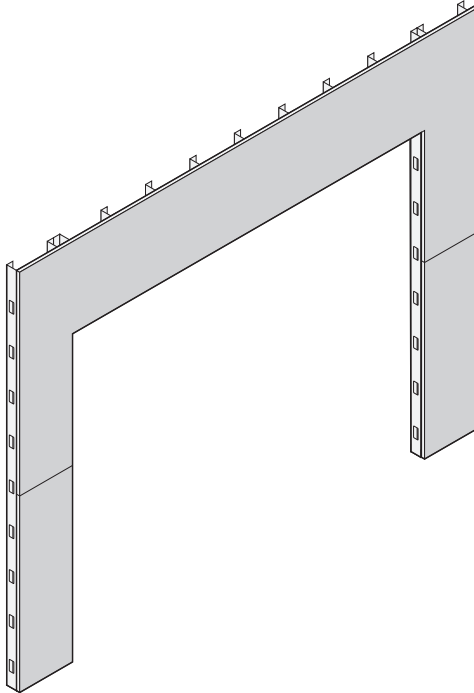

STEP 1

A. Cut rough opening in sheathing for window.

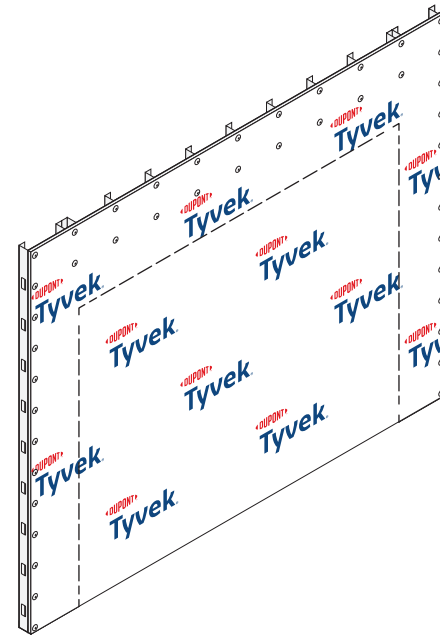

STEP 2

A. Wrap wall as shown in the [DuPont™ Tyvek® WRB Installation Instructions](#) section in this guide. Do not install fasteners within 6" of the jambs of the openings and within 9" of the head of the openings.

Installation Methods for DuPont Self-Adhered Flashing Products Installed **AFTER** the DuPont™ Tyvek® WRB Storefront Window on Slab

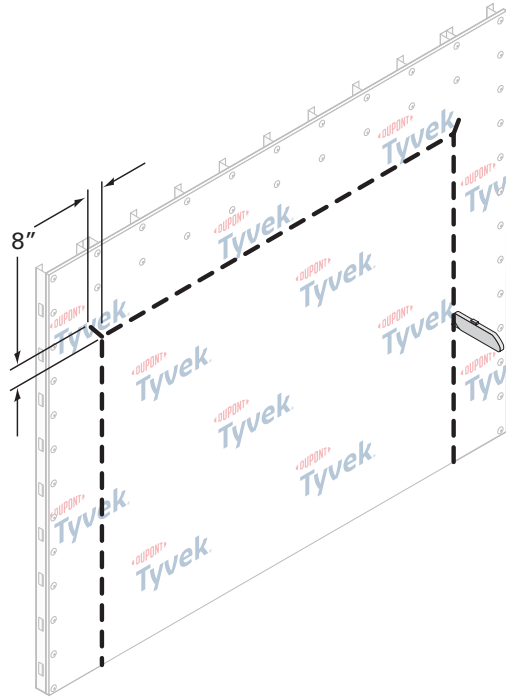

STEP 3

Prepare the Tyvek® WRB for Window Installation

- Cut an opening in the Tyvek® WRB using a flush cut around the perimeter of the rough opening.
- Cuts should be made along the dashed indicated lines. (Ensure that the Tyvek® WRB is cut flush with the sheathing and is not wrapped into the rough opening.)
- Cut a head flap at a 45° angle to expose 8" of sheathing to allow for head flashing installation.

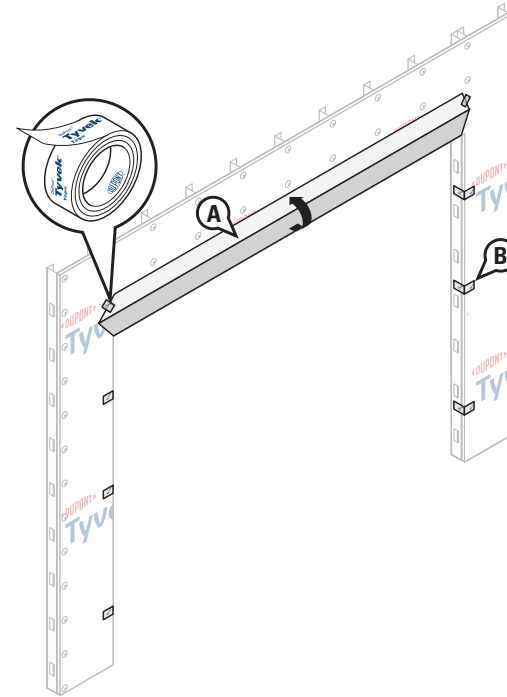

STEP 4

- Flip the head flap up to expose the sheathing and temporarily secure with tape.
- Temporarily secure Tyvek® WRB with DuPont™ Tyvek® Tape around rough opening before flashing is installed to help facilitate flashing installation.

Installation Methods for DuPont Self-Adhered Flashing Products Installed AFTER the DuPont™ Tyvek® WRB Storefront Window on Slab

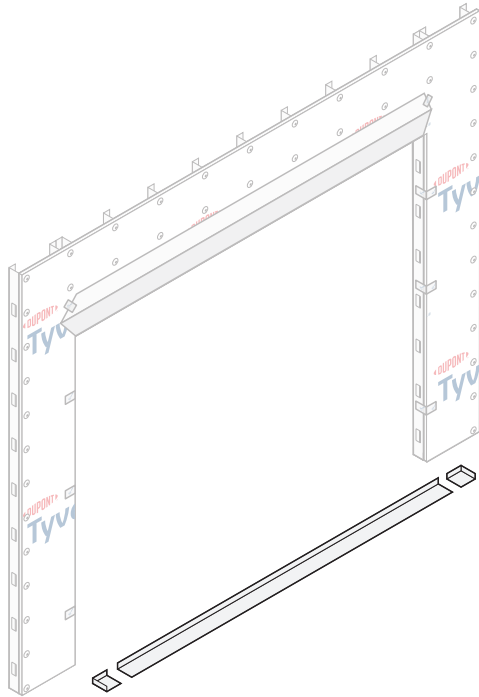

STEP 5

- A. Prepare the sill flashing per manufacturer's recommendation and seal the corner pan flashing with sealant.
- B. Inspect installation surface to ensure surface is free of dirt or substances that could interfere with adhesion as well as any sharp protrusions.

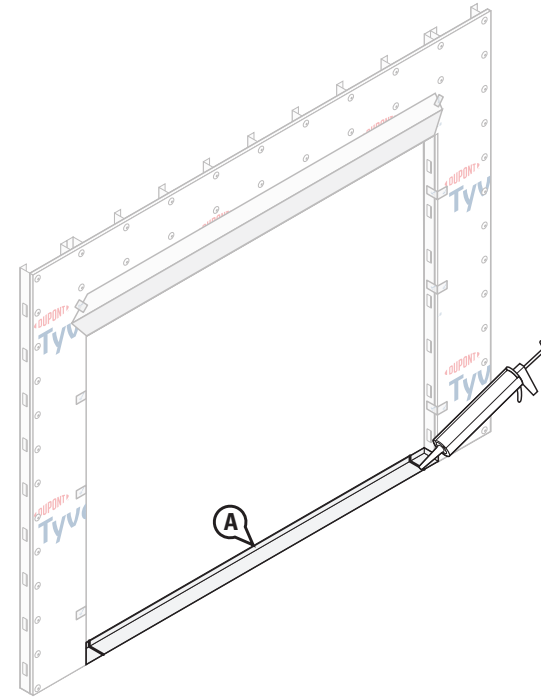

STEP 6

- A. Shim, level and anchor pan per manufacturer's instructions flashing to concrete.
- B. Seal corner pan flashing seams with recommended sealant. Refer to [Chemical Compatibility of Representative Building Sealants and Adhesives/Primers](#) for more information on recommended sealants.

Installation Methods for DuPont Self-Adhered Flashing Products Installed AFTER the DuPont™ Tyvek® WRB Storefront Window on Slab

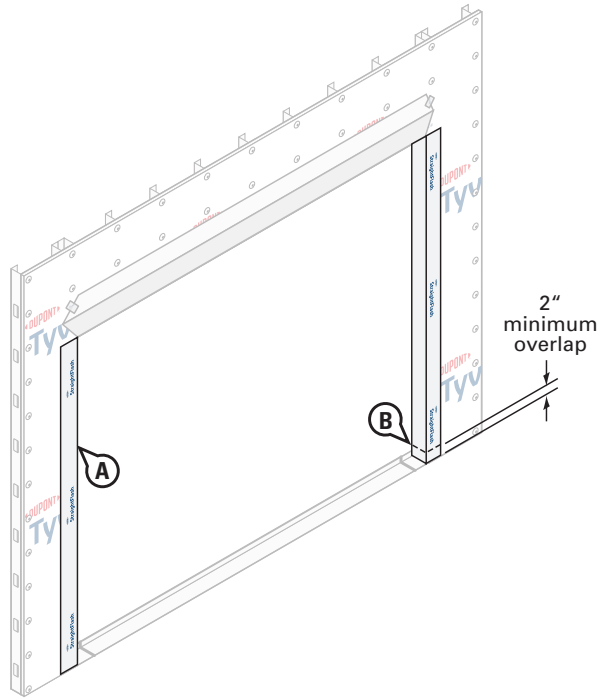

STEP 7

- A. Wrap 9" DuPont™ StraightFlash™ into the rough opening at each jamb and onto wall face. The flashing should align with the interior edge of the jamb framing. Cut the jamb flashing the vertical length of the rough opening.
- B. Jamb flashing should be long enough to overlap the sill flashing by at least 2" and be overlapped by future head flashing by at least 2".

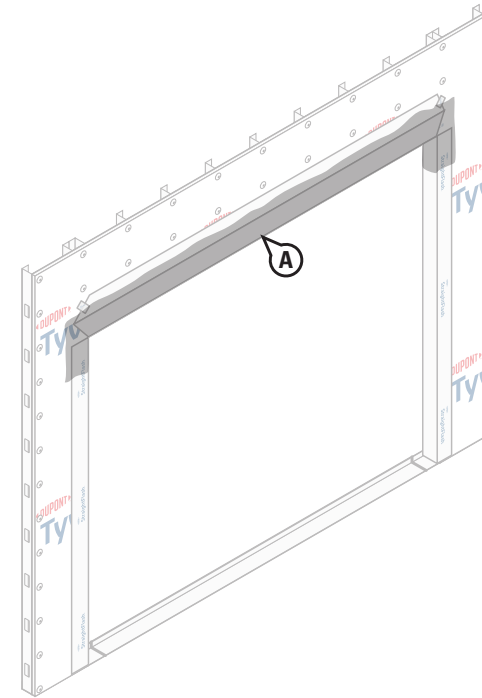

STEP 8

- A. Apply a recommended adhesive/primer to the top of the jambs and exposed sheathing. Refer to [Chemical Compatibility of Representative Building Sealants and Adhesives/Primers](#) for more information on recommended adhesives/primers.

Installation Methods for DuPont Self-Adhered Flashing Products Installed AFTER the DuPont™ Tyvek® WRB Storefront Window on Slab

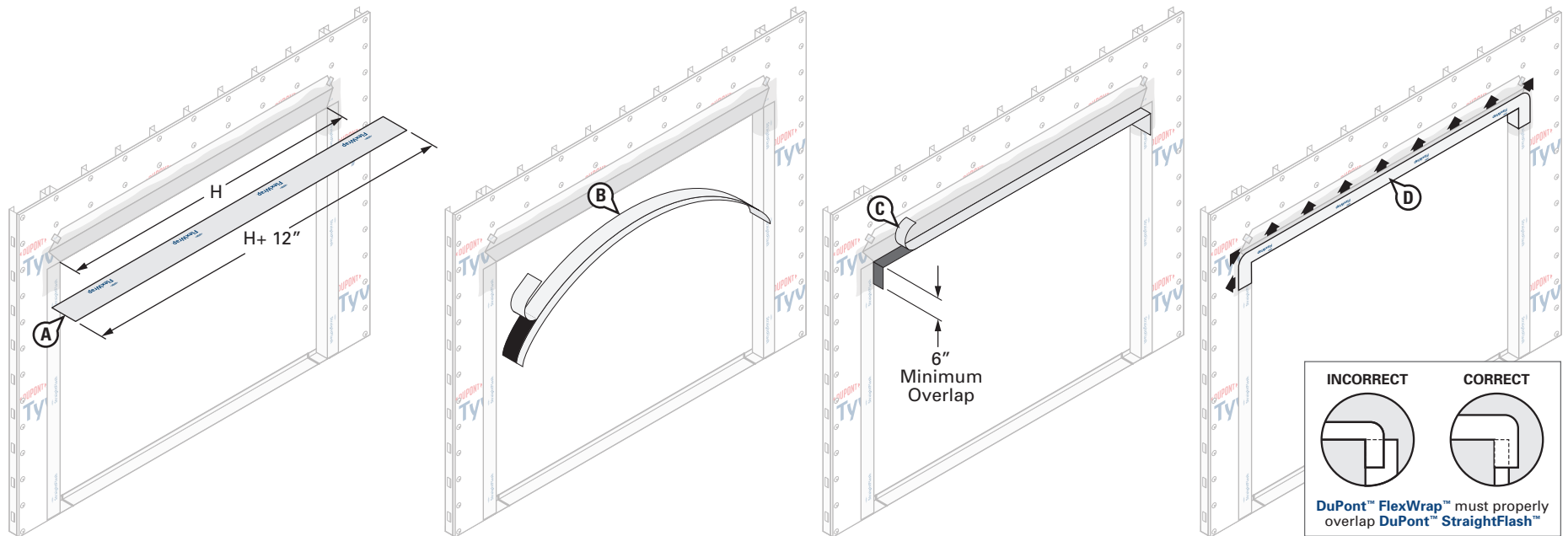

STEP 9

Install DuPont™ FlexWrap™ at Head

- A. Cut **FlexWrap™** at least 12" **LONGER** than the width of rough opening head (H). Use roll widths sufficient to achieve a minimum of 1" adhesion **BEYOND** where the back of the window frame will be located, ensuring 2"– 3" adhesion onto the face of the wall.
- B. Fold the **FlexWrap™** in half lengthwise to create a slight crease at the center. Remove the wide piece of release paper on one side of the fold. Align the inside edge of the narrow release paper with the face of the wall to ensure 2"– 3" of the **FlexWrap™** will be adhered to the face of the wall. Starting at the crease, adhere the **FlexWrap™** at the center of the horizontal portion of the head framing to ensure a minimum of 6" down each jamb. Adhere into rough opening at one corner and down the jamb. Remove the remaining release paper, and repeat at opposite corner.
- C. Remove narrow release paper.
- D. Fan out the **FlexWrap™** at corners and adhere onto face of wall. Continue adhering onto face of wall along the head.
- E. Use sufficient width of **FlexWrap™** to avoid reverse shingling of flashing at the jamb and head interface. See detail above.

NOTE: DuPont™ Tyvek® Commercial Certified Installers may install a 3-piece head (and sill) detail for window openings less than 6 ft. wide. Installers who **are not** DuPont™ Tyvek® Commercial Certified Installers should refer to the [Special Considerations](#) section for more information regarding the 3-piece head/sill detail. Contact your local DuPont Building Envelope Specialist for more information about the Certified Installer program.

Installation Methods for DuPont Self-Adhered Flashing Products Installed AFTER the DuPont™ Tyvek® WRB Storefront Window on Slab

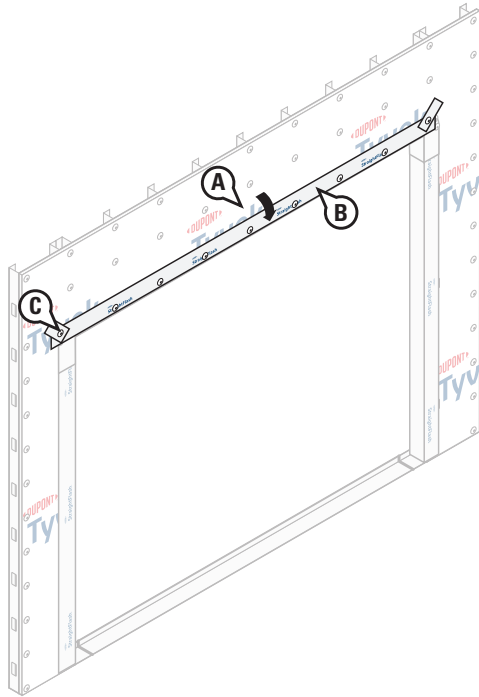

STEP 10

- Flip down the head flap and **trim 1"– 2" above the window opening**.
- Starting along the horizontal, terminate the head flap with 4" **DuPont™ StraightFlash™**. (See [Special Considerations](#) for allowances for using 4" **DuPont™ StraightFlash™** or 3" **Tyvek® Tape** in lieu of **StraightFlash™**).
- Install **DuPont™ Tyvek® Wrap Cap Fasteners** or recommended fasteners at head according to the fastening schedule (every 12" to 18" depending on the vertical stud line).

NOTE: For a more robust install, areas with extreme wind load exposures, or high performance testing use 4" **StraightFlash™** to seal the head flap and install additional mechanical fasteners through the flashing at the head flap and perimeter of window.

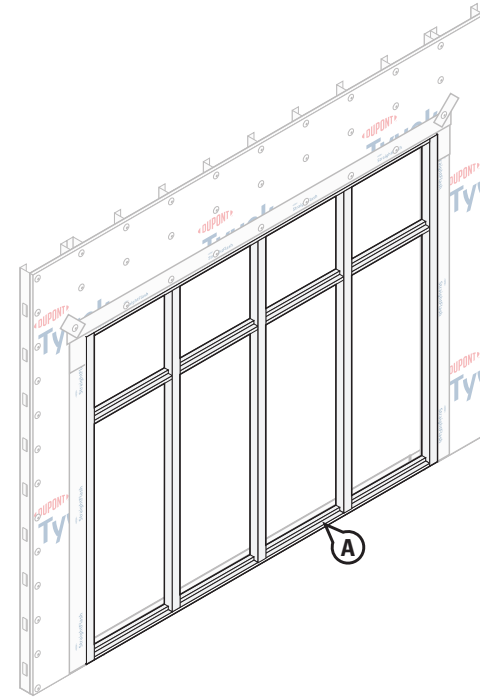

STEP 11

- Install store front window per manufacturer's installation instructions.
- Glaze windows per manufacturer's instructions.

Installation Methods for DuPont Self-Adhered Flashing Products Installed AFTER the DuPont™ Tyvek® WRB Storefront Window on Slab

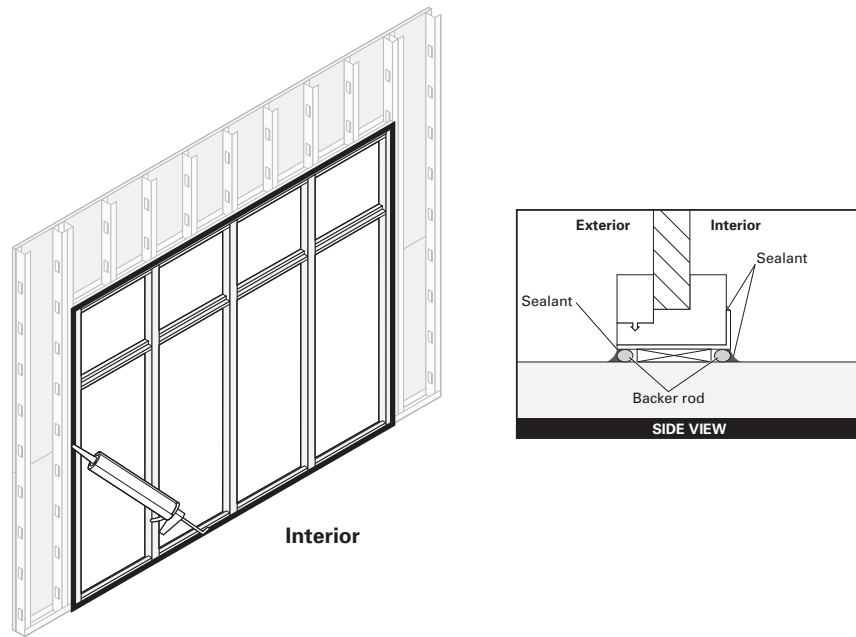

STEP 12

Final Step

Create a continuous perimeter seal using backer rod and recommended sealant or **Great Stuff Pro™ Window and Door Polyurethane Foam Sealant** on window interior to resist air and water infiltration. When using **Great Stuff Pro™ Window and Door Polyurethane Foam Sealant** in perimeter openings less than ½", apply using the plastic extension tip for the **Great Stuff Pro™ Dispenser Gun** during installation. Refer to [Chemical Compatibility of Representative Building Sealants and Adhesives/Primers](#) for more information on recommended sealants.

NOTE: For high performance installations exceeding ASTM E1677 wind loading pressures (10.8 psf, 65 mph equivalent structural load) and ASTM E331 water infiltration resistance of 6.24 psf, it is necessary to install sealant over the cured foam when using **Great Stuff Pro™ Window and Door Polyurethane Foam Sealant** or other recommended foam. Sealant should be installed over the foam between the window frame and rough opening around the entire interior perimeter. If **Great Stuff Pro™ Window and Door Polyurethane Foam Sealant** or other recommended foam extends **BEYOND** the window frame, shave the excess cured foam flush with the window frame before applying sealant. Avoid damaging the **DuPont Self-Adhered Flashing Product**.

Installation Methods for DuPont Self-Adhered Flashing Products Installed **AFTER** the DuPont™ Tyvek® WRB Storefront Window on Knee Wall

This method applies to the following products: DuPont™ StraightFlash™ and DuPont™ FlexWrap™

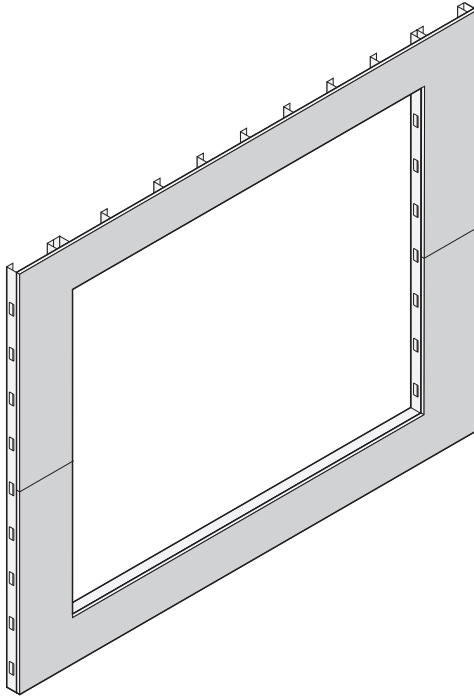

STEP 1

- A. Cut rough opening in sheathing for window. Ensure that sheathing is cut flush with, or slightly below the sill framing to allow for positive drainage.

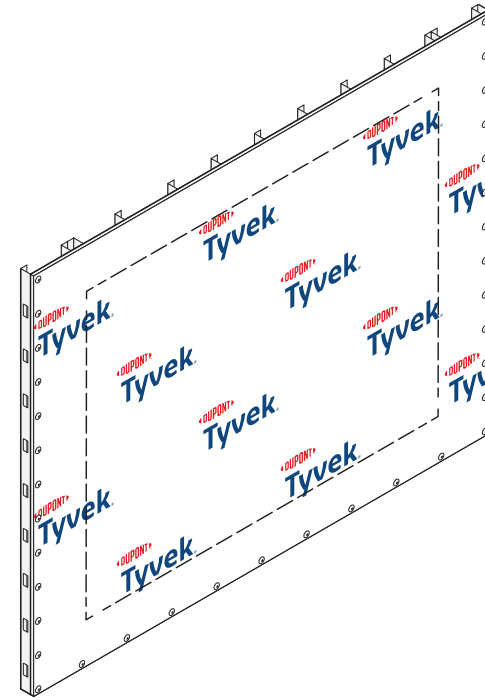

STEP 2

- A. Wrap wall as shown in the [DuPont™ Tyvek® WRB Installation Instructions](#) section in this guide. Do not install fasteners within 6" of the sills and jambs of the openings and within 9" of the head of the openings.

Installation Methods for DuPont Self-Adhered Flashing Products Installed **AFTER** the DuPont™ Tyvek® WRB Storefront Window on Knee Wall

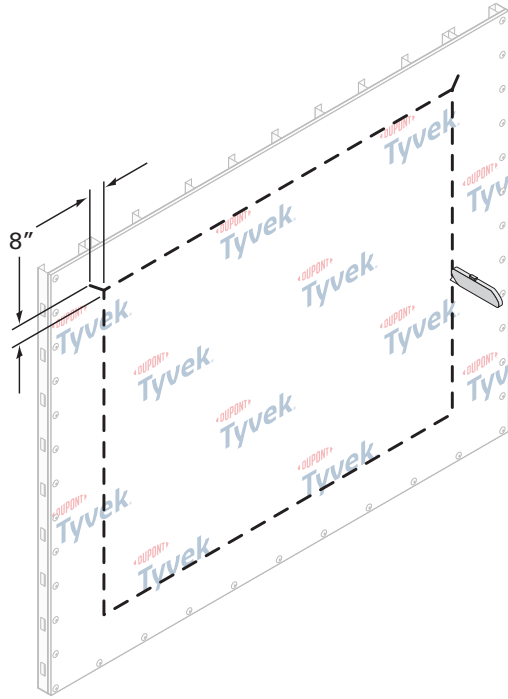

STEP 3

Prepare the Tyvek® WRB for Window Installation

- Cut an opening in the Tyvek® WRB using a flush cut (“O-Cut”) around the perimeter of the rough opening.
- Cuts should be made along the dashed indicated lines. (Ensure that the Tyvek® WRB is cut flush with the sheathing and is not wrapped into the rough opening.)
- Cut a head flap at a 45° angle to expose 8” of sheathing to allow for head flashing installation.

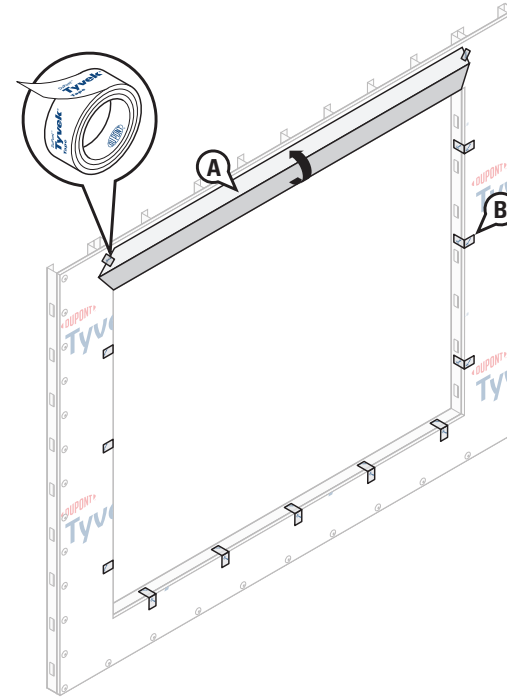

STEP 4

- Flip the head flap up to expose the sheathing and temporarily secure with tape.
- Temporarily secure Tyvek® WRB with DuPont™ Tyvek® Tape around rough opening before flashing is installed to help facilitate flashing installation.

Installation Methods for DuPont Self-Adhered Flashing Products Installed **AFTER** the DuPont™ Tyvek® WRB Storefront Window on Knee Wall

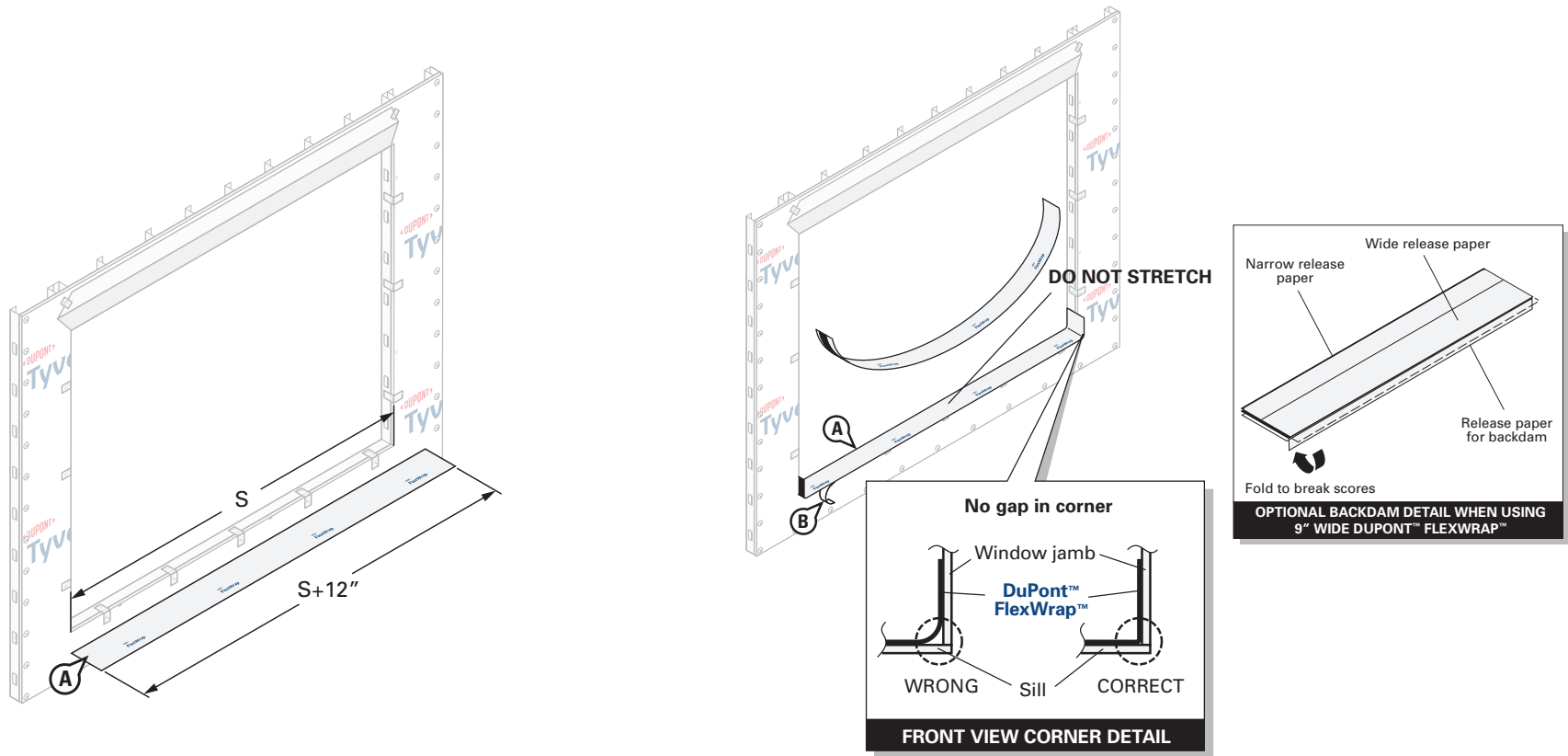

STEP 5

- A. Cut **DuPont™ FlexWrap™** at least 12" **LONGER** than the width of rough opening sill (S). Use roll widths sufficient to achieve a minimum of 1" adhesion **BEYOND** where the back of the window frame will be located, ensuring 2"– 3" adhesion onto the face of the wall.
- B. Inspect installation surface to ensure surface is free of dirt or substances that could interfere with adhesion as well as any sharp protrusions.

NOTE: DuPont™ Tyvek® Commercial Certified Installers may install a 3-piece head (and sill) detail for window openings less than 6 ft. wide. Installers who **are not** DuPont™ Tyvek® Commercial Certified Installers should refer to the [Special Considerations](#) section for more information regarding the 3-piece head/sill detail. Contact your local DuPont Building Envelope Specialist for more information about the Certified Installer program.

STEP 6

- A. Remove wide piece of release paper. Position on horizontal sill by aligning the inside edge of the narrow release paper with the face of the wall to ensure 2"– 3" of the **FlexWrap™** will be adhered to the face of the wall with a minimum of 6" up each jamb. Adhere into rough opening.
- Optional Back Dam:** Fold 9" **FlexWrap™** to break perforation. Remove center piece of release paper. Cover horizontal sill to accommodate back dam as appropriate, and adhere into rough opening along sill and up jambs (min 6" on each side). Leave 1" release paper on **FlexWrap™** inside rough opening to finish back dam after window installation.
- B. Remove narrow release paper.
- C. Firmly press **FlexWrap™** into the corners

Installation Methods for DuPont Self-Adhered Flashing Products Installed AFTER the DuPont™ Tyvek® WRB

Storefront Window on Knee Wall

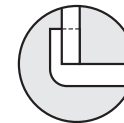
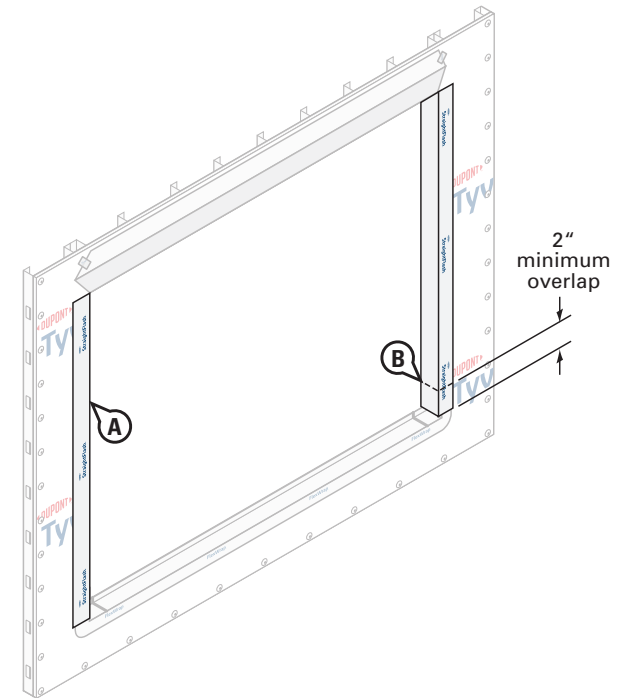
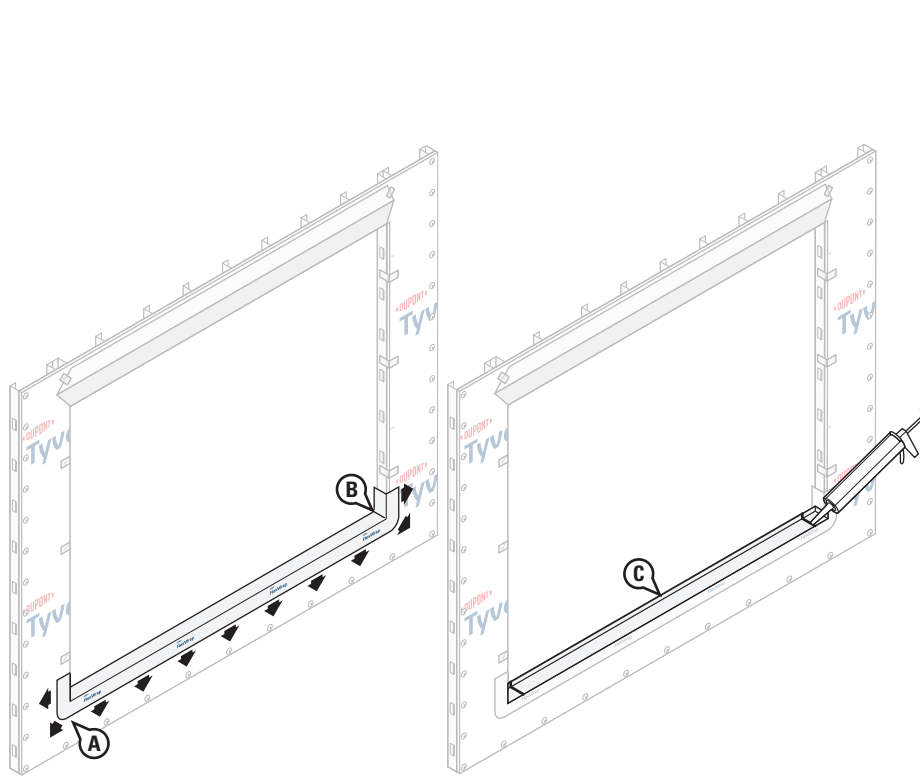

INCORRECT
DuPont™ FlexWrap™
reverse flashed

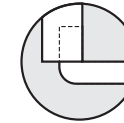

CORRECT
DuPont™ StraightFlash™
overlaps FlexWrap™

STEP 7

- Fan out the **DuPont™ FlexWrap™** at corners and adhere onto face of wall. Continue adhering onto face of wall along sill.
- Firmly press sill flashing to ensure full adhesion on all surfaces. Eliminate wrinkles and bubbles by smoothing surface and repositioning as necessary.
- Shim, level and anchor sill pan flashing and seal corner seams per manufacturer's instructions with recommended sealant. Refer to [Chemical Compatibility of Representative Building Sealants and Adhesives/Primers](#) for more information on recommended sealants.

STEP 8

- Wrap 9" **DuPont™ StraightFlash™** into the rough opening at each jamb and onto wall face. The flashing should align with the interior edge of the jamb framing. Cut the jamb flashing the vertical length of the rough opening.
- Jamb flashing should be long enough to overlap the sill flashing by at least 2" and be overlapped by future head flashing by at least 2".

Installation Methods for DuPont Self-Adhered Flashing Products Installed **AFTER** the DuPont™ Tyvek® WRB Storefront Window on Knee Wall

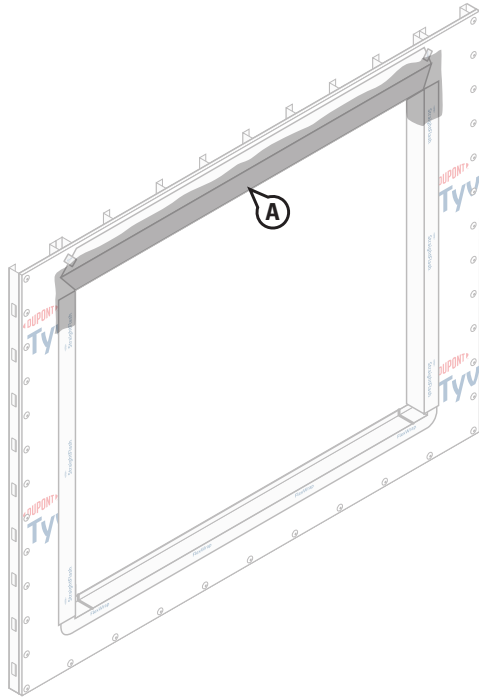

STEP 9

- A. Apply a recommended adhesive/primer to the top of the jambs and exposed sheathing. Refer to [Chemical Compatibility of Representative Building Sealants and Adhesives/Primers](#) for more information on recommended adhesives/primers.

Installation Methods for DuPont Self-Adhered Flashing Products Installed **AFTER** the DuPont™ Tyvek® WRB Storefront Window on Knee Wall

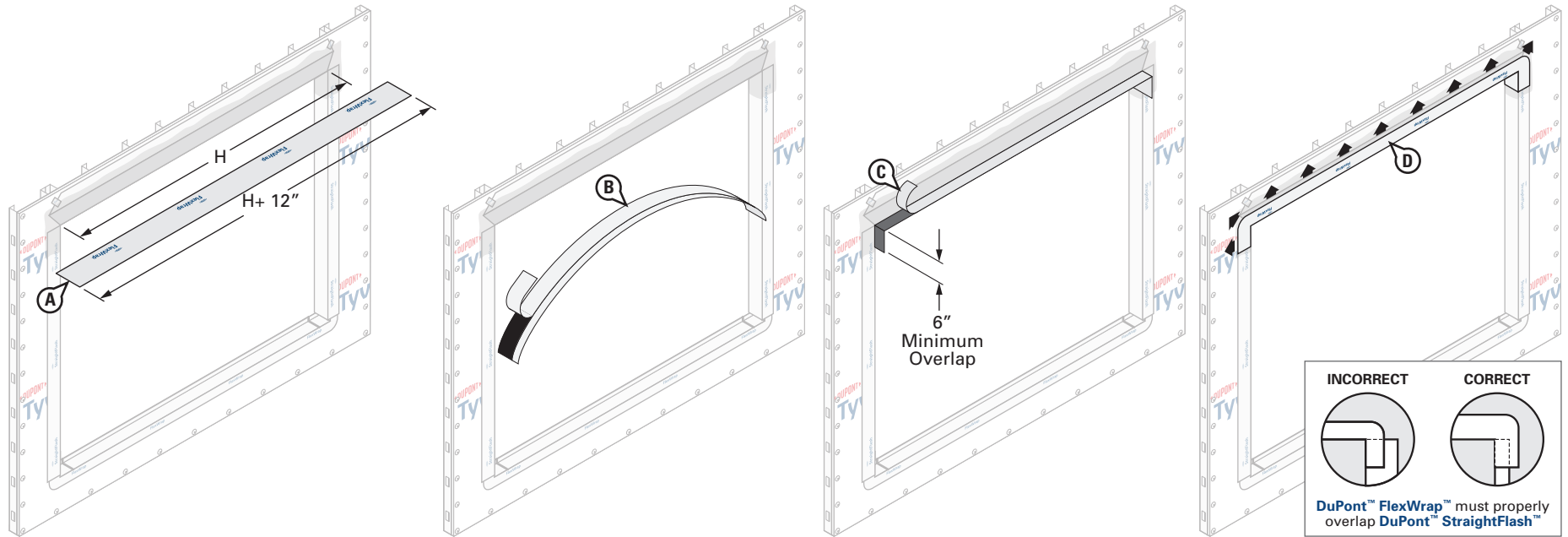

STEP 10

Install DuPont™ FlexWrap™ at Head

- A. Cut **FlexWrap™** at least 12" **LONGER** than the width of rough opening head (H). Use roll widths sufficient to achieve a minimum of 1" adhesion **BEYOND** where the back of the window frame will be located, ensuring 2"– 3" adhesion onto the face of the wall.
- B. Fold the **FlexWrap™** in half lengthwise to create a slight crease at the center. Remove the wide piece of release paper on one side of the fold. Align the inside edge of the narrow release paper with the face of the wall to ensure 2"– 3" of the **FlexWrap™** will be adhered to the face of the wall. Starting at the crease, adhere the **FlexWrap™** at the center of the horizontal portion of the head framing to ensure a minimum of 6" down each jamb. Adhere into rough opening at one corner and down the jamb. Remove the remaining release paper, and repeat at opposite corner.
- C. Remove narrow release paper.
- D. Fan out the **FlexWrap™** at corners and adhere onto face of wall. Continue adhering onto face of wall along the head.
- E. Use sufficient width of **FlexWrap™** to avoid reverse shingling of flashing at the jamb and head interface. See detail above.

NOTE: DuPont™ Tyvek® Commercial Certified Installers may install a 3-piece head (and sill) detail for window openings less than 6 ft. wide. Installers who **are not** DuPont™ Tyvek® Commercial Certified Installers should refer to the [Special Considerations](#) section for more information regarding the 3-piece head/sill detail. Contact your local DuPont Building Envelope Specialist for more information about the Certified Installer program.

Installation Methods for DuPont Self-Adhered Flashing Products Installed AFTER the DuPont™ Tyvek® WRB Storefront Window on Knee Wall

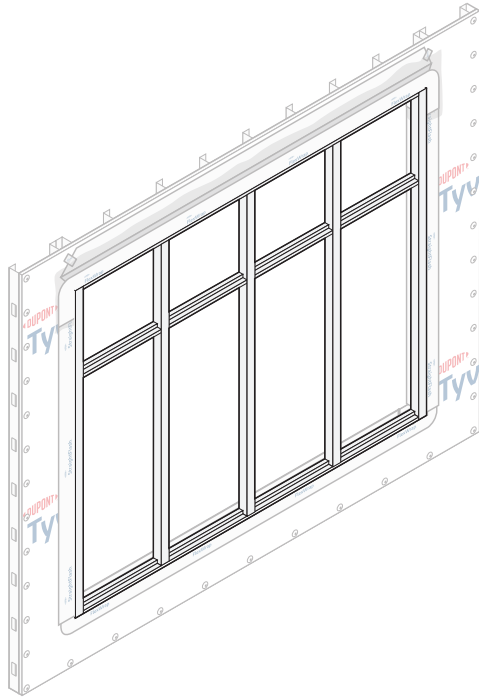

STEP 11

- A. Install storefront window per manufacturer's installation instructions.
- B. Glaze windows per manufacturer's instructions.

NOTE: Ensure window and sealant installation allows for drainage at the sill. If sealant is applied at the sill, as a best practice, ensure that there are at least two (2) 2" gaps in the sealant bead for every 4" of window to allow for drainage.

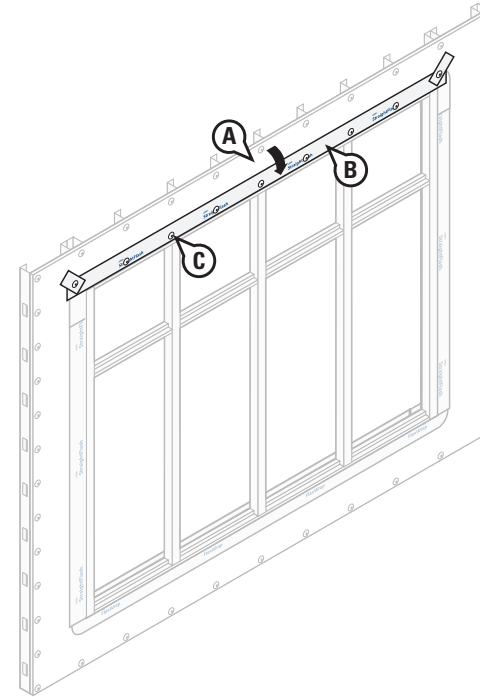

STEP 12

- A. Flip down the head flap and **trim 1"– 2" above the window opening.**
- B. Starting along the horizontal, terminate the head flap with 4" **DuPont™ StraightFlash™**. (See [Special Considerations](#) for allowances for using 4" **DuPont™ StraightFlash™** or 3" **Tyvek® Tape** in lieu of **StraightFlash™**).
- C. Install remaining **DuPont™ Tyvek® Wrap Cap Fasteners** or recommended fasteners at head per the fastening schedule (every 12" to 18" depending on the vertical stud line).

NOTE: For a more robust install, areas with extreme wind load exposures, or high performance testing use 4" **StraightFlash™** to seal the head flap and install additional mechanical fasteners through the flashing at the head flap and perimeter of window.

Installation Methods for DuPont Self-Adhered Flashing Products Installed AFTER the DuPont™ Tyvek® WRB Storefront Window on Knee Wall

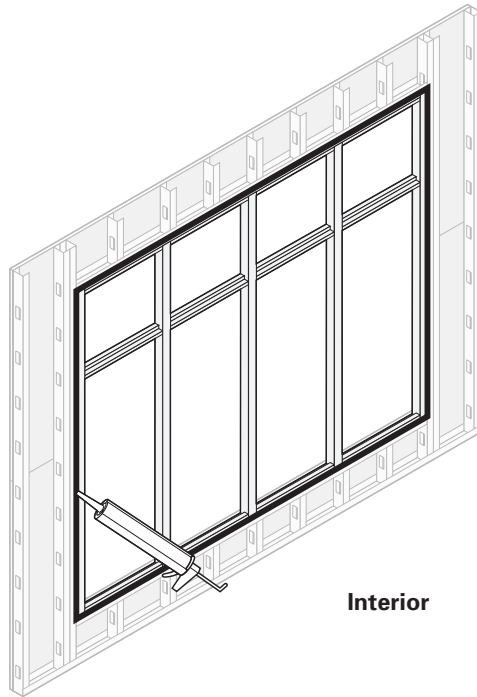

STEP 13

Final Step

Create a continuous perimeter seal using backer rod and recommended sealant or **Great Stuff Pro™ Window and Door Polyurethane Foam Sealant** on window interior to resist air and water infiltration. When using **Great Stuff Pro™ Window and Door Polyurethane Foam Sealant** in perimeter openings less than 1/2", apply using the plastic extension tip for the **Great Stuff Pro™ Dispenser Gun** during installation. Refer to [Chemical Compatibility of Representative Building Sealants and Adhesives/Primers](#) for more information on recommended sealants.

NOTE: For high performance installations exceeding ASTM E1677 wind loading pressures (10.8 psf, 65 mph equivalent structural load) and ASTM E331 water infiltration resistance of 6.24 psf, it is necessary to install sealant over the cured foam when using **Great Stuff Pro™ Window and Door Polyurethane Foam Sealant** or other recommended foam. Sealant should be installed over the foam between the window frame and rough opening around the entire interior perimeter. If **Great Stuff Pro™ Window and Door Polyurethane Foam Sealant** or other recommended foam extends **BEYOND** the window frame, shave the excess cured foam flush with the window frame before applying sealant. Avoid damaging the **DuPont Self-Adhered Flashing Product**.

Installation Methods for DuPont Self-Adhered Flashing Products Installed **AFTER** the DuPont™ Tyvek® WRB Integral Flanged Window

This method applies to the following products: DuPont™ StraightFlash™ and DuPont™ FlexWrap™

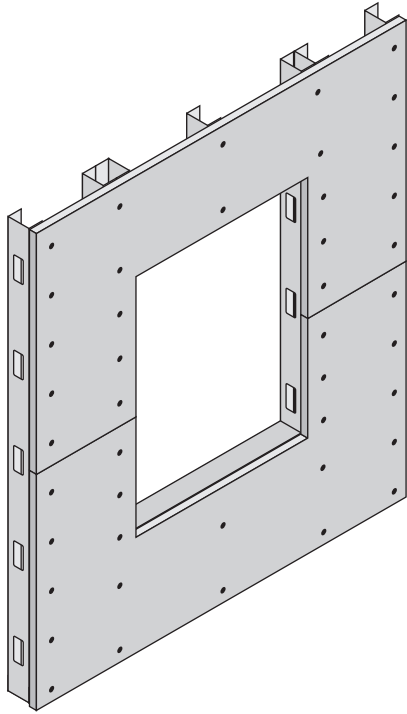

STEP 1

D. Cut rough opening in sheathing for window. Ensure that sheathing is cut flush with, or slightly below the sill framing to allow for positive drainage.

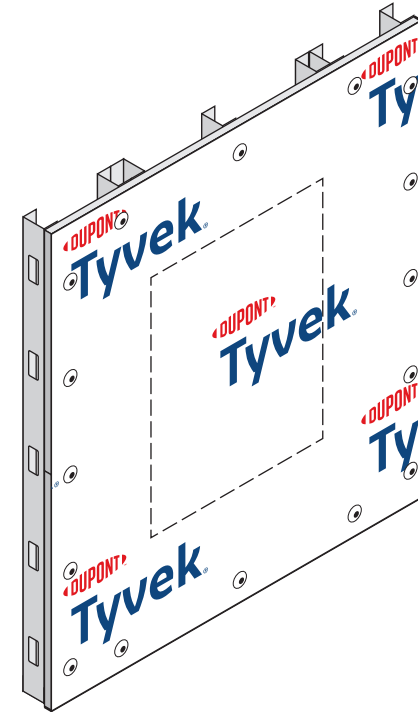

STEP 2

A. Wrap wall as shown in the [DuPont™ Tyvek® WRB Installation Instructions](#) section in this guide. Do not install fasteners within 6" of the sills and jambs of the openings and within 9" of the head of the openings.

Installation Methods for DuPont Self-Adhered Flashing Products Installed AFTER the DuPont™ Tyvek® WRB Integral Flanged Window

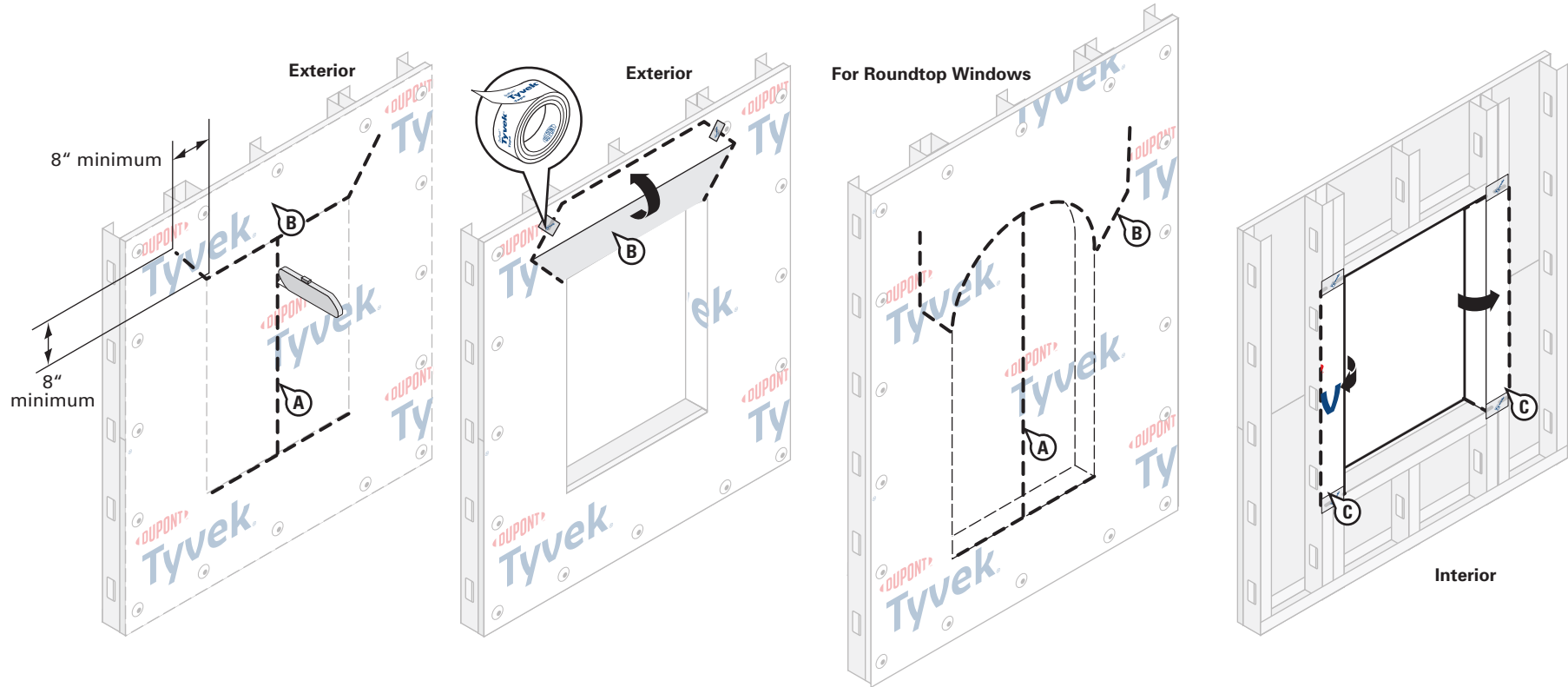

STEP 3

Prepare Tyvek® WRB for Window Installation

- Make an "I-Cut" in the Tyvek® WRB. For an "I-Cut" begin with a horizontal cut across the bottom and the top of the window frame (for round top windows, the cut should begin 2" above the mull joint). From the center cut straight down to the sill.
- Cut two 45° degree slits a minimum of 8" from the corner of the header to create a flap above the rough opening to expose sheathing or framing members and to allow head flashing installation (see step 5). Flip head flap up and temporarily secure with DuPont™ Tyvek® Tape. Some windows and flashing widths may require longer slits.

- Fold side flaps into rough opening, cut excess flaps, and secure.

NOTE: See the details in this guide for [Alternative Flashing Methods A, B, and C](#) for flanged windows aligned with Section 7 of FMA/AAMA 100-12, *Standard Practice for the Installation of Windows with Flanges or Mounting Fins in Wood Framed Construction for Extreme Wind/Water Conditions*.

Installation Methods for DuPont Self-Adhered Flashing Products Installed AFTER the DuPont™ Tyvek® WRB Integral Flanged Window

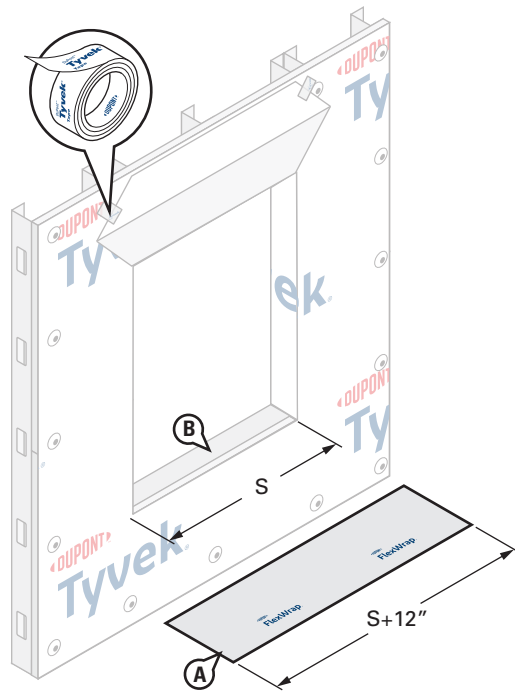

STEP 4

- Cut **DuPont™ FlexWrap™** at least 12" **LONGER** than the width of rough opening sill (S). Use roll widths sufficient to achieve a minimum of 1" adhesion **BEYOND** where the back of the window frame will be located, ensuring 2"– 3" adhesion onto the face of the wall.
- Inspect installation surface to ensure surface is free of dirt or substances that could interfere with adhesion as well as any sharp protrusions.

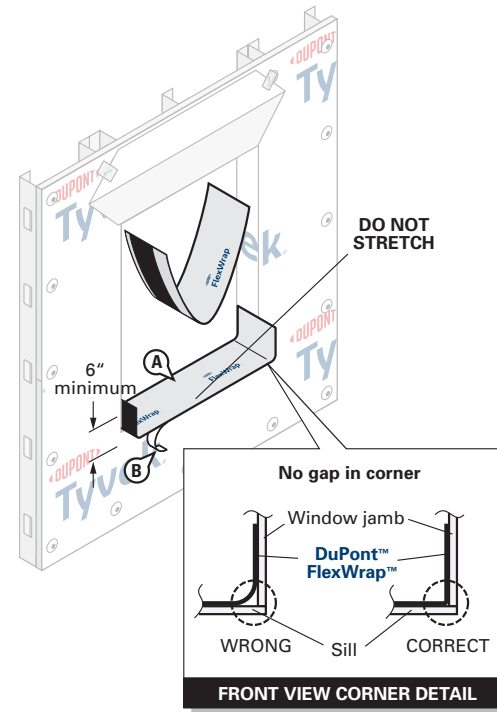

STEP 5

- Remove wide piece of release paper. Position on horizontal sill by aligning the inside edge of the narrow release paper with the face of the wall to ensure 2"– 3" of the **FlexWrap™** will be adhered to the face of the wall with a minimum of 6" up each jamb. Adhere into rough opening.

Optional Back Dam: Fold 9" **FlexWrap™** to break perforation. Remove center piece of release paper. Cover horizontal sill to accommodate back dam as appropriate, and adhere into rough opening along sill and up jambs (min 6" on each side). Leave 1" release paper on **FlexWrap™** inside rough opening to finish back dam after window installation.

- Remove narrow release paper.

NOTE: DuPont™ Tyvek® Commercial Certified Installers may install a 3-piece head (and sill) detail for window openings less than 6 ft. wide. Installers who **are not** DuPont™ Tyvek® Commercial Certified Installers should refer to the [Special Considerations](#) section for more information regarding the 3-piece head/sill detail. Contact your local DuPont Building Envelope Specialist for more information about the Certified Installer program.

Installation Methods for DuPont Self-Adhered Flashing Products Installed AFTER the DuPont™ Tyvek® WRB Integral Flanged Window

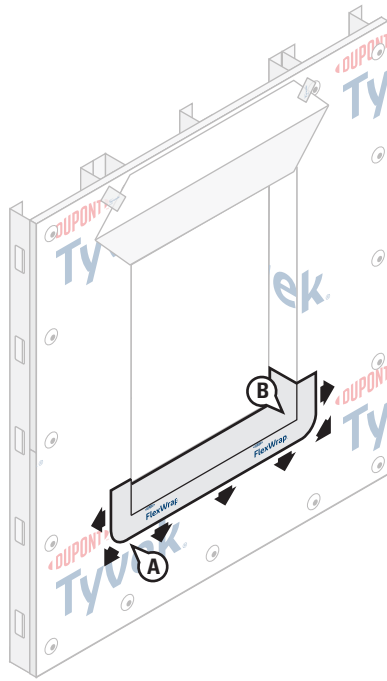

STEP 6

- A. Fan out the **DuPont™ FlexWrap™** at corners and adhere onto face of wall. Continue adhering onto face of wall along sill.
- B. Firmly press sill flashing to ensure full adhesion on all surfaces. Eliminate wrinkles and bubbles by smoothing surface and repositioning as necessary.

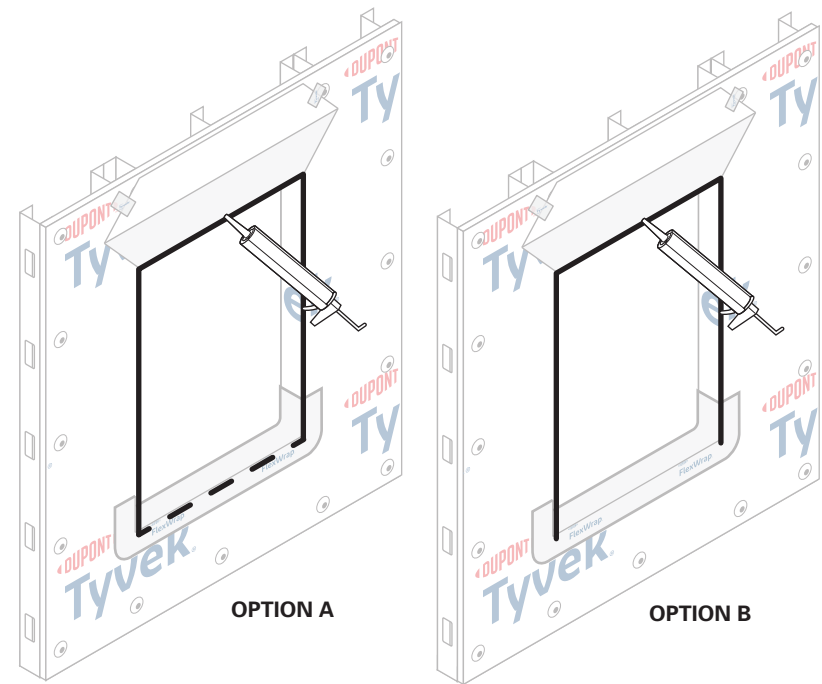

STEP 7

OPTION A: Apply a continuous bead of a recommended sealant at window head and jambs to wall or back side of window mounting flange. To allow for drainage, do not apply continuous sealant bead along sill. Ensure a minimum 2" wide drainage gap in the sealant bead within 4" from each corner of the jamb-sill interface. Continue applying a recommended sealant along the sill with additional 2" wide (min.) drainage gaps for every 6"- 12" (on center) of sill width. Refer to [Chemical Compatibility of Representative Building Sealants and Adhesives/Primers](#) for more information on recommended sealants.

OPTION B: Apply a continuous bead of a recommended sealant at window head and jambs to wall or back side of window mounting flange. To allow for drainage, do not apply sealant bead along sill.

Installation Methods for DuPont Self-Adhered Flashing Products Installed AFTER the DuPont™ Tyvek® WRB Integral Flanged Window

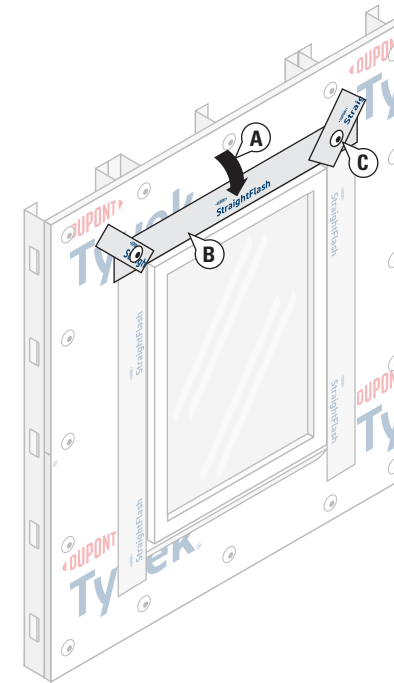
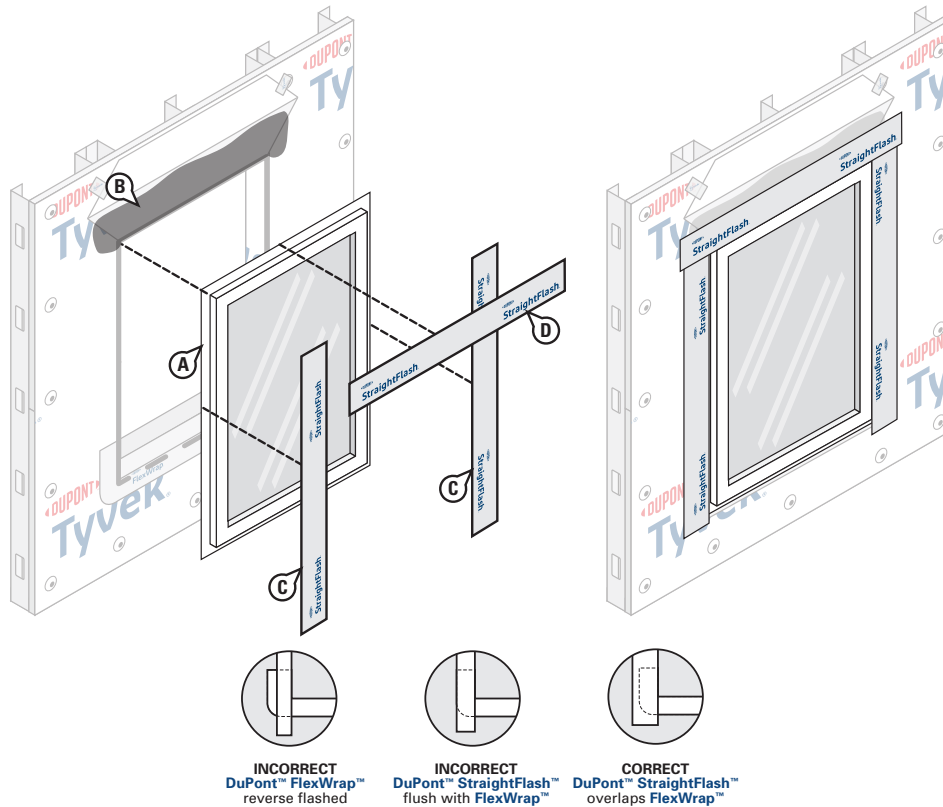

STEP 8

- Install window according to manufacturer's instructions.
- Apply a recommended adhesive/primer to exposed sheathing. Refer to [Chemical Compatibility of Representative Building Sealants and Adhesives/Primers](#) for more information on recommended adhesives/primers.
- Cut two pieces of **DuPont™ StraightFlash™** or **DuPont™ Flashing Tape*** for jamb flashing extending 1" above window head flange and 2" to 4" below bottom edge of sill flashing. Remove release paper and press tightly along sides of window frame.
- Cut a piece of **StraightFlash™** or **DuPont™ Flashing Tape*** for head flashing, which extends **BEYOND** the outer edges of jamb flashings. Remove release paper and install completely covering mounting flange and adhering to exposed sheathing or framing members.

STEP 9

- Flip down upper flap of **Tyvek® WRB** so it lays flat across head flashing, then trim **1"– 2" above the window opening**.
- Starting along the horizontal, terminate the head flap with 4" **DuPont™ StraightFlash™**. (See [Special Considerations](#) for allowances for using 4" **DuPont™ Flashing Tape** or 3" **Tyvek® Tape** in lieu of **StraightFlash™**).
- Install **DuPont™ Tyvek® Wrap Cap Fasteners** or recommended fasteners at appropriate spacing at head.

NOTE: For extreme wind load exposure and/or designated air barrier performance aligned with ASTM E2357 use 4" **StraightFlash™** to seal the head flap and install additional mechanical fasteners through the flashing at the head flap and perimeter of window.

***DuPont™ Flashing Tape** is only permitted for Residential-Use building structures. Residential-Use (Group R) is defined by the 2018/2021 International Building Code.

Installation Methods for DuPont Self-Adhered Flashing Products Installed AFTER the DuPont™ Tyvek® WRB

Integral Flanged Window

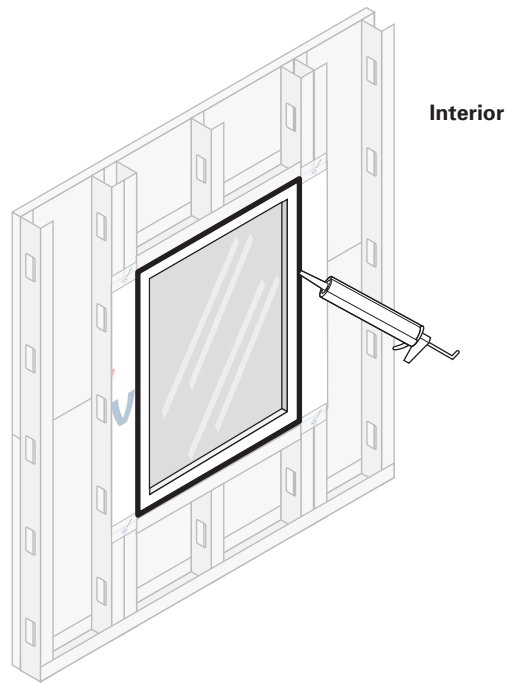

For Roundtop Windows

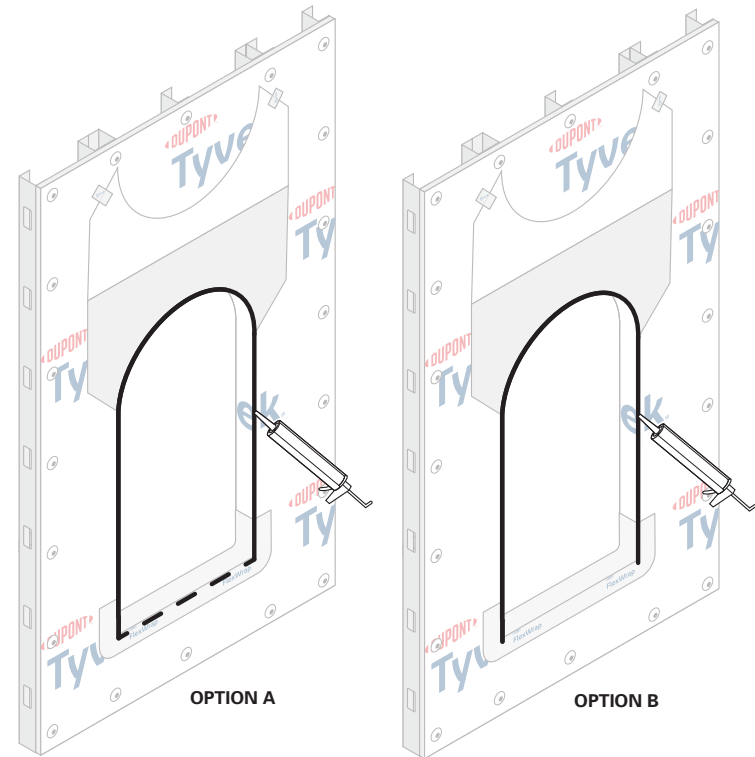

STEP 10

Final Step

Create a continuous perimeter seal using backer rod and recommended sealant or **Great Stuff Pro™ Window and Door Polyurethane Foam Sealant** on window interior to resist air and water infiltration. When using **Great Stuff Pro™ Window and Door Polyurethane Foam Sealant** in perimeter openings less than 1/2", apply using the plastic extension tip for the **Great Stuff Pro™ Dispenser Gun** during installation.

NOTE: For high performance installations exceeding ASTM E1677 wind loading pressures (10.8 psf, 65 mph equivalent structural load) and ASTM E331 water infiltration resistance of 6.24 psf, it is necessary to install sealant over the cured foam when using **Great Stuff Pro™ Window and Door Polyurethane Foam Sealant** or other recommended foam. Sealant should be installed over the foam between the window frame and rough opening around the entire interior perimeter. If **Great Stuff Pro™ Window and Door Polyurethane Foam Sealant** or other recommended foam extends **BEYOND** the window frame, shave the excess cured foam flush with the window frame before applying sealant. Avoid damaging the **DuPont Self-Adhered Flashing Product** or **DuPont™ Tyvek® WRB**.

STEP 8

NOTE: Follow rectangular window instructions (Steps 1 through 6) for proper installation of sill flashing prior to installation of the sealant in this step, round top window, and head flashing.

OPTION A: Apply a continuous bead of a recommended sealant at window head and jambs to wall or back side of window mounting flange. **To allow for drainage, do not apply continuous sealant bead along sill.** Ensure a minimum 2" wide drainage gap in the sealant bead within 4" from **each corner** of the jamb-sill interface. Continue applying sealant along the sill with additional 2" wide (minimum) drainage gaps for every 6"- 12" (on center) of sill width. Refer to [Chemical Compatibility of Representative Building Sealants and Adhesives/Primers](#) for more information on recommended sealants.

OPTION B: Apply a continuous bead of a recommended sealant at window head and jambs to wall or back side of window mounting flange. **To allow for drainage, do not apply sealant bead along sill.**

Installation Methods for DuPont Self-Adhered Flashing Products Installed AFTER the DuPont™ Tyvek® WRB

Integral Flanged Window

For Roundtop Windows

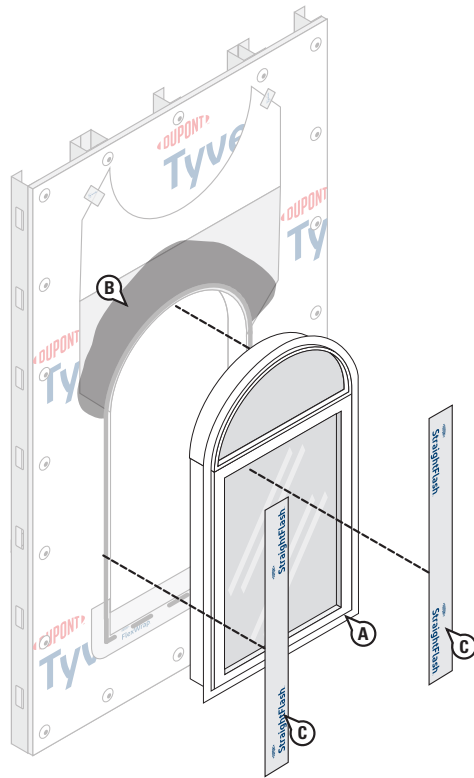

STEP 9

- Install window according to manufacturer's instructions.
- Apply a recommended adhesive/primer to the top of the jambs and exposed sheathing. Refer to [Chemical Compatibility of Representative Building Sealants and Adhesives/Primers](#) for more information on recommended adhesives/primers.
- Cut two pieces of DuPont™ StraightFlash™ or DuPont™ Flashing Tape* for jamb flashing extending 1" above window head flange and 2" to 4" below bottom edge of sill flashing. Remove release paper and press tightly along sides of window frame.

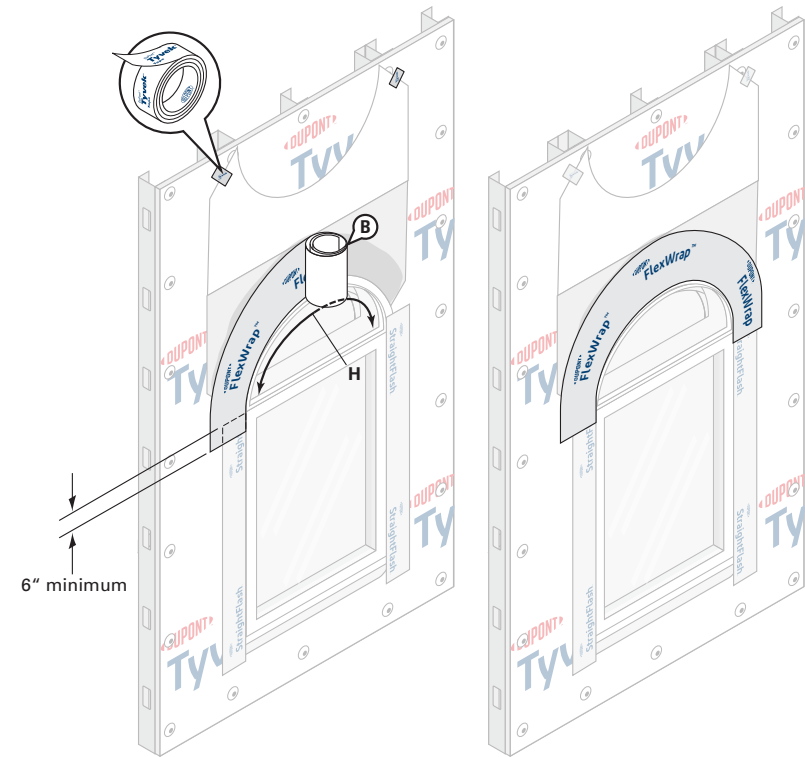

STEP 10

Install Head Flashing

- Cut DuPont™ FlexWrap™ head flashing at least 12" **LONGER** than the arc length (H) of round-top window.
- Remove both release papers and install to conform around top of window, covering entire mounting flange and adhering to exposed sheathing or framing members. Head flashing should overlap jamb flashings at least 6".

*DuPont™ Flashing Tape is only permitted for Residential-Use building structures. Residential-Use (Group R) is defined by the 2018/2021 International Building Code.

Installation Methods for DuPont Self-Adhered Flashing Products Installed AFTER the DuPont™ Tyvek® WRB

Integral Flanged Window

For Roundtop Windows

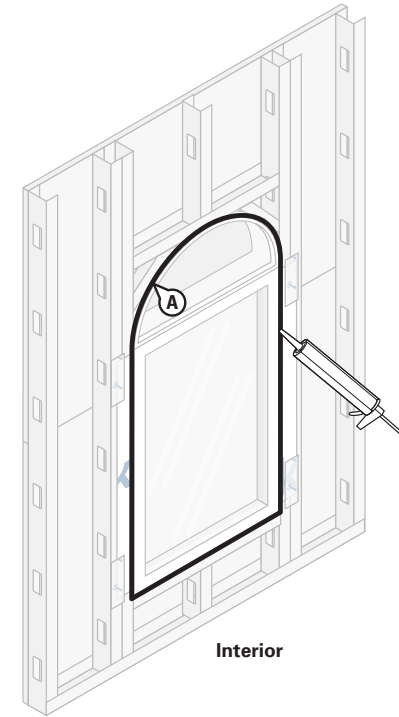
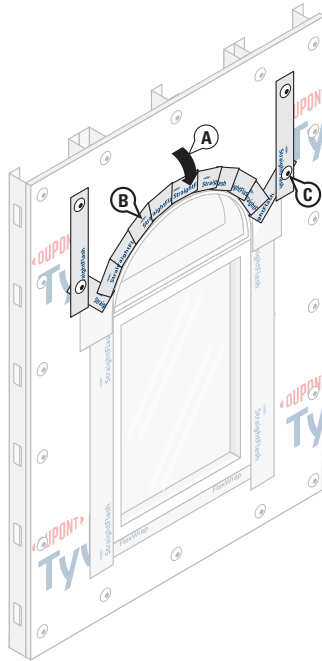

STEP 11

- Flip down upper flap of **Tyvek® WRB** so it lays flat across head flashing, then **trim 1"– 2" above the window opening**.
- Starting along the horizontal, terminate the head flap with 4" **DuPont™ StraightFlash™**. (See [Special Considerations](#) for allowances for using 4" **DuPont™ StraightFlash™** or 3" **Tyvek® Tape** in lieu of **StraightFlash™**).
- Install **DuPont™ Tyvek® Wrap Cap Fasteners** or recommended fastener at appropriate spacing at head.

NOTE: For a more robust install, areas with extreme wind load exposures, or high performance testing use 4" **StraightFlash™** to seal the head flap and install additional mechanical fasteners through the flashing at the head flap and perimeter of window.

STEP 12

Final Step

Create a continuous perimeter seal using backer rod and recommended sealant or **Great Stuff Pro™ Window and Door Polyurethane Foam Sealant** on window interior to resist air and water infiltration. When using **Great Stuff Pro™ Window and Door Polyurethane Foam Sealant** in perimeter openings less than ½", apply using the plastic extension tip for the **Great Stuff Pro™ Dispenser Gun** during installation.

NOTE: For high performance installations exceeding ASTM E1677 wind loading pressures (10.8 psf, 65 mph equivalent structural load) and ASTM E331 water infiltration resistance of 6.24 psf, it is necessary to install sealant over the cured foam when using **Great Stuff Pro™ Window and Door Polyurethane Foam Sealant** or other recommended foam. Sealant should be installed over the foam between the window frame and rough opening around the entire interior perimeter. If **Great Stuff Pro™ Window and Door Polyurethane Foam Sealant** or other recommended foam extends **BEYOND** the window frame, shave the excess cured foam flush with the window frame before applying sealant. Avoid damaging the **DuPont Self-Adhered Flashing Product** or **DuPont™ Tyvek® WRB**.

*DuPont™ Flashing Tape is only permitted for Residential-Use building structures. Residential-Use (Group R) is defined by the 2018/2021 International Building Code.

Installation Methods for DuPont Self-Adhered Flashing Products Installed **AFTER** the DuPont™ Tyvek® WRB Integral Flanged Window with DuPont™ FlexWrap™ along the Rough Opening Head

This method (i.e. DuPont™ FlexWrap™ applied to the head of the rough opening prior to installation of an integral flanged window) can be used for all integral flanged window conditions captured within this guide.

This method applies to the following products: DuPont™ StraightFlash™ and DuPont™ FlexWrap™

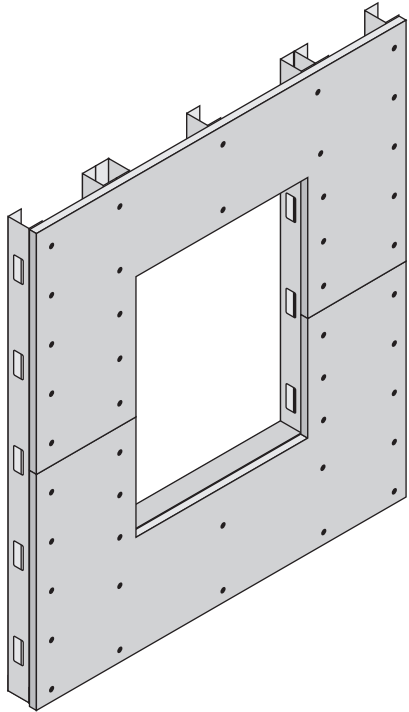

STEP 1

- A. Cut rough opening in sheathing for window. Ensure that sheathing is cut flush with, or slightly below the sill framing to allow for positive drainage.

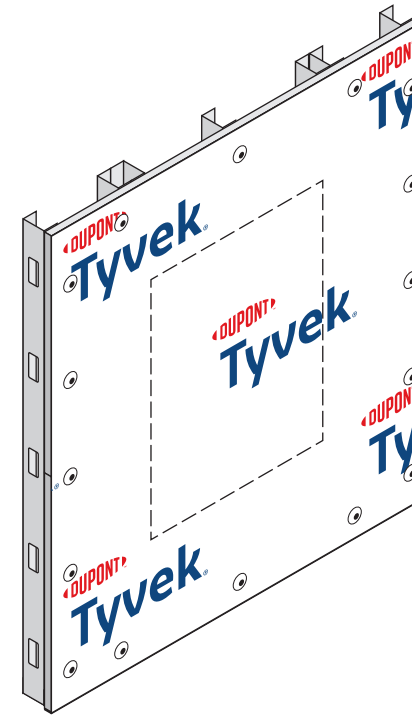

STEP 2

- A. Wrap wall as shown in the [DuPont™ Tyvek® WRB Installation Instructions](#) section in this guide. Do not install fasteners within 6" of the sills and jambs of the openings and within 9" of the head of the openings.

Installation Methods for DuPont Self-Adhered Flashing Products Installed **AFTER** the DuPont™ Tyvek® WRB Integral Flanged Window with DuPont™ FlexWrap™ along the Rough Opening Head

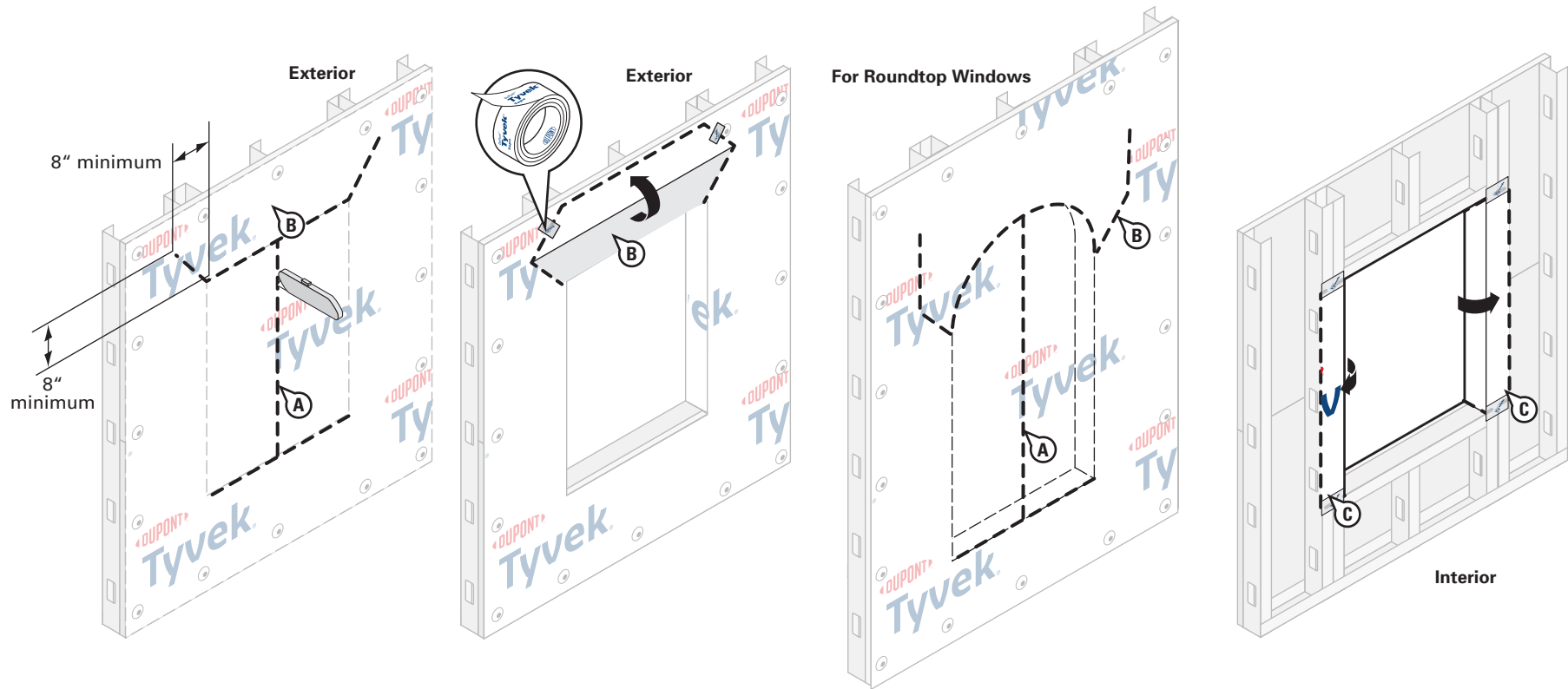

STEP 3

Prepare Tyvek® WRB for Window Installation

- A. Make an “I-Cut” in the Tyvek® WRB. For an “I-Cut” begin with a horizontal cut across the bottom and the top of the window frame (for round top windows, the cut should begin 2” above the mull joint). From the center cut straight down to the sill.
- B. Cut two 45° degree slits a minimum of 8” from the corner of the header to create a flap above the rough opening to expose sheathing or framing members and to allow head flashing installation (see step 5). Flip head flap up and temporarily secure with DuPont™ Tyvek™ Tape. Some windows and flashing widths may require longer slits.

- C. Fold side flaps into rough opening, cut excess flaps, and secure.

NOTE: See the details in this guide for alternative flashing [Methods A, B, and C](#) for flanged windows aligned with Section 7 of FMA/AAMA 100-12, *Standard Practice for the Installation of Windows with Flanges or Mounting Fins in Wood Framed Construction for Extreme Wind/Water Conditions*.

Installation Methods for DuPont Self-Adhered Flashing Products Installed **AFTER** the DuPont™ Tyvek® WRB Integral Flanged Window with DuPont™ FlexWrap™ along the Rough Opening Head

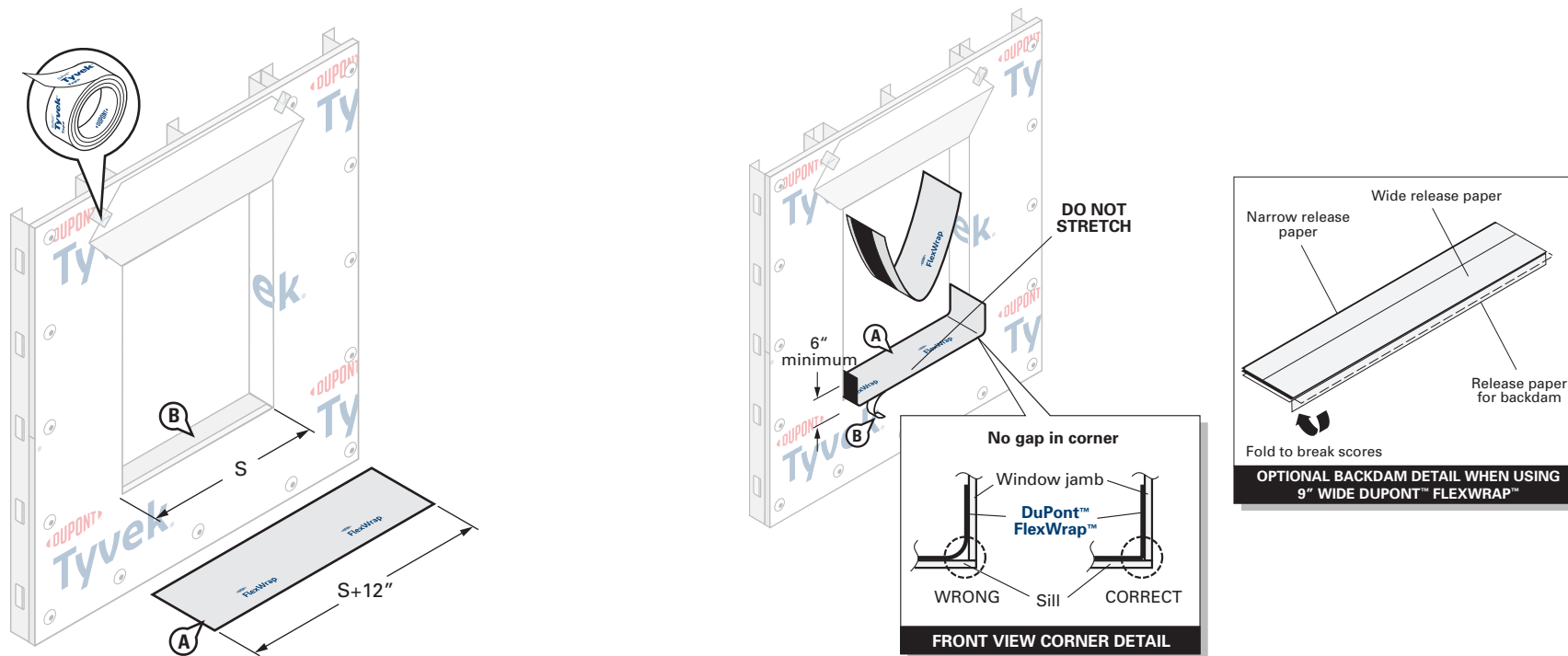

STEP 4

- Cut **DuPont™ FlexWrap™** at least 12" **LONGER** than the width of rough opening sill (S). Use roll widths sufficient to achieve a minimum of 1" adhesion **BEYOND** where the back of the window frame will be located, ensuring 2"– 3" adhesion onto the face of the wall.
- Inspect installation surface to ensure surface is free of dirt or substances that could interfere with adhesion as well as any sharp protrusions.

STEP 5

- Remove wide piece of release paper. Position on horizontal sill by aligning the inside edge of the narrow release paper with the face of the wall to ensure 2"– 3" of the **FlexWrap™** will be adhered to the face of the wall with a minimum of 6" up each jamb. Adhere into rough opening.

Optional Back Dam: Fold 9" **FlexWrap™** to break perforation. Remove center piece of release paper. Cover horizontal sill to accommodate back dam as appropriate, and adhere into rough opening along sill and up jambs (min 6" on each side). Leave 1" release paper on **FlexWrap™** inside rough opening to finish back dam after window installation.

- Remove narrow release paper.

NOTE: DuPont™ Tyvek® Commercial Certified Installers may install a 3-piece head (and sill) detail for window openings less than 6 ft. wide. Installers who **are not** DuPont™ Tyvek® Commercial Certified Installers should refer to the [Special Considerations](#) section for more information regarding the 3-piece head/sill detail. Contact your local DuPont Building Envelope Specialist for more information about the Certified Installer program.

Installation Methods for DuPont Self-Adhered Flashing Products Installed **AFTER** the DuPont™ Tyvek® WRB Integral Flanged Window with DuPont™ FlexWrap™ along the Rough Opening Head

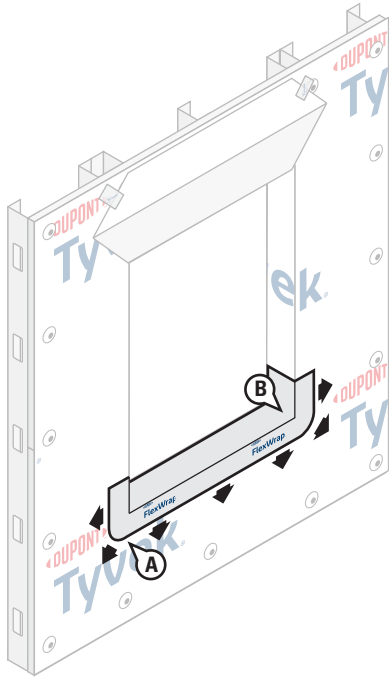

STEP 6

- A. Fan out the **DuPont™ FlexWrap™** at corners and adhere onto face of wall. Continue adhering onto face of wall along sill.
- B. Firmly press sill flashing to ensure full adhesion on all surfaces. Eliminate wrinkles and bubbles by smoothing surface and repositioning as necessary.

Installation Methods for DuPont Self-Adhered Flashing Products Installed **AFTER** the DuPont™ Tyvek® WRB Integral Flanged Window with DuPont™ FlexWrap™ along the Rough Opening Head

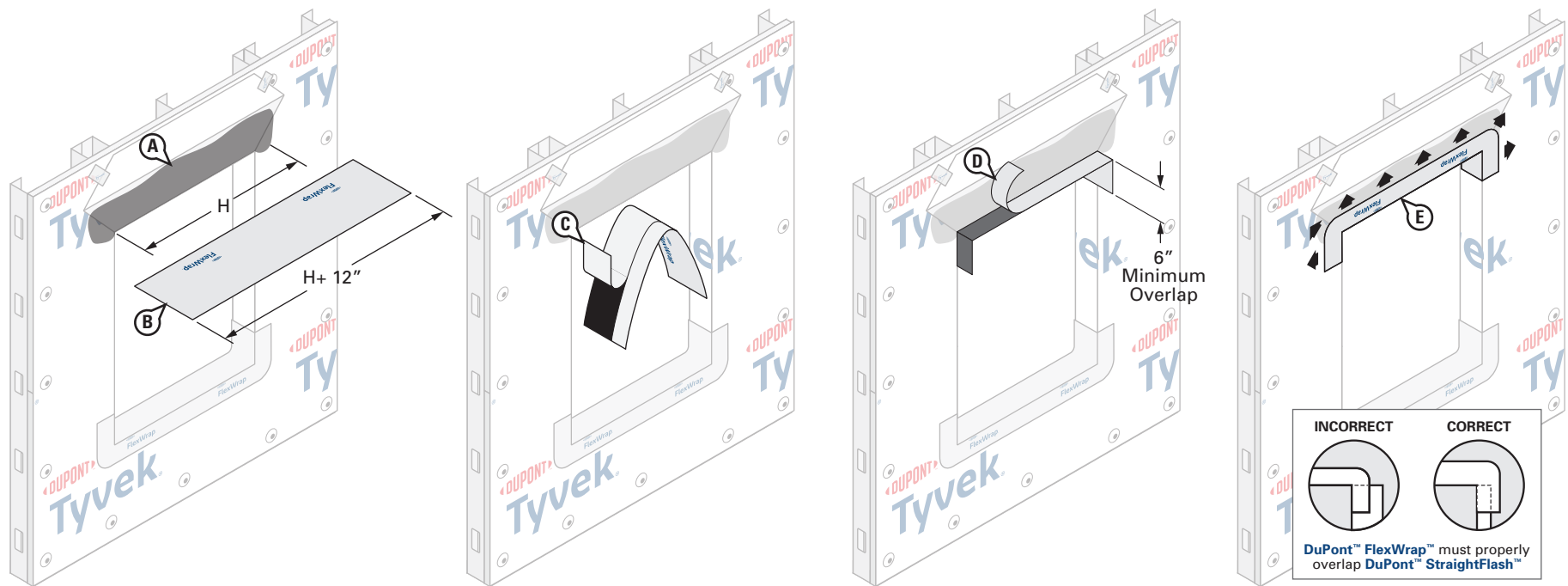

STEP 7

Install FlexWrap™ Head Flashing

- Apply a recommended adhesive/primer to exposed sheathing. Refer to [Chemical Compatibility of Representative Building Sealants and Adhesives/Primers](#) for more information on recommended adhesives/primers.
- Cut **FlexWrap™** at least 12" **LONGER** than width of rough opening head (H). Use roll widths sufficient to achieve a minimum of 1" adhesion **BEYOND** where the back of the window frame will be located, ensuring 2"– 3" adhesion onto the face of the wall.
- Fold the **FlexWrap™** in half lengthwise to create a slight crease at the center. Remove the wide piece of release paper on one side of the fold. Align the inside edge of the narrow release paper with the face of the wall to ensure 2"– 3" of the **FlexWrap™** will be adhered to the face of the wall. Starting at the crease, adhere

the **FlexWrap™** at the center of the horizontal portion of the head framing to ensure a minimum of 6" down each jamb. Adhere into rough opening at one corner and down the jamb. Remove the remaining release paper, and repeat at opposite corner.

- Remove narrow release paper.
- Fan out the **FlexWrap™** at corners and adhere onto face of wall. Continue adhering onto face of wall along the head.

NOTE: DuPont™ Tyvek® Certified Installers may install a 3-piece head (and sill) detail for window openings less than 6 ft. wide. Installers who **are not** DuPont™ Tyvek® Commercial Certified Installers should refer to the [Special Considerations](#) section for more information regarding the 3-piece head/sill detail. Contact your local DuPont Building Envelope Specialist for more information about the Certified Installer program.

Installation Methods for DuPont Self-Adhered Flashing Products Installed **AFTER** the DuPont™ Tyvek® WRB Integral Flanged Window with DuPont™ FlexWrap™ along the Rough Opening Head

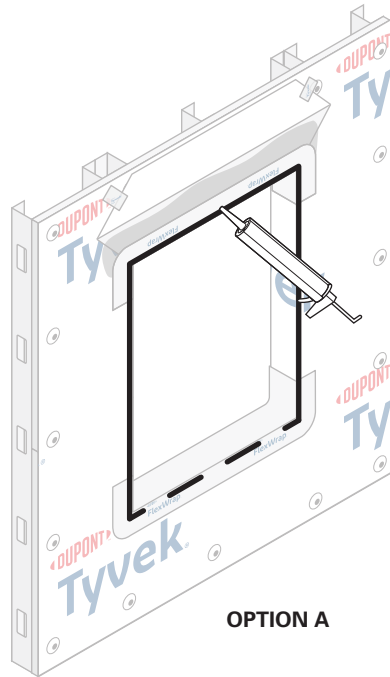

OPTION A

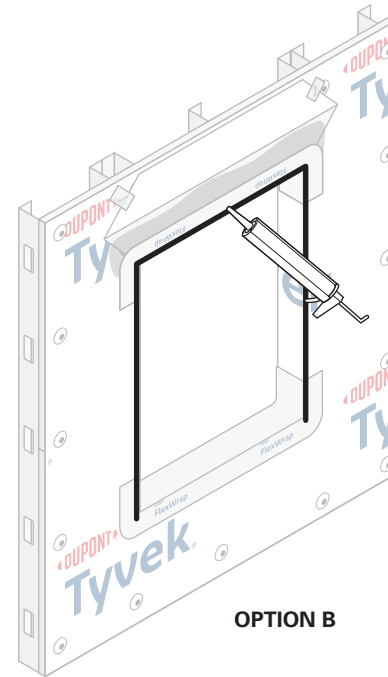

OPTION B

STEP 8

Recommended Sealant Application

OPTION A: Apply a continuous bead of a recommended sealant at window head and jambs to wall or back side of window mounting flange. To allow for drainage, do not apply continuous sealant bead along sill. Ensure a minimum 2" wide drainage gap in the sealant bead within 4" from each corner of the jamb-sill interface. Continue applying sealant along the sill with additional 2" wide (min.) drainage gaps for every 6"-12" (on center) of sill width. Refer to [Chemical Compatibility of Representative Building Sealants and Adhesives/Primers](#) for more information on recommended sealants.

OPTION B: Apply a continuous bead of a recommended sealant at window head and jambs to wall or back side of window mounting flange. To allow for drainage, do not apply sealant bead along sill.

Installation Methods for DuPont Self-Adhered Flashing Products Installed **AFTER** the DuPont™ Tyvek® WRB Integral Flanged Window with DuPont™ FlexWrap™ along the Rough Opening Head

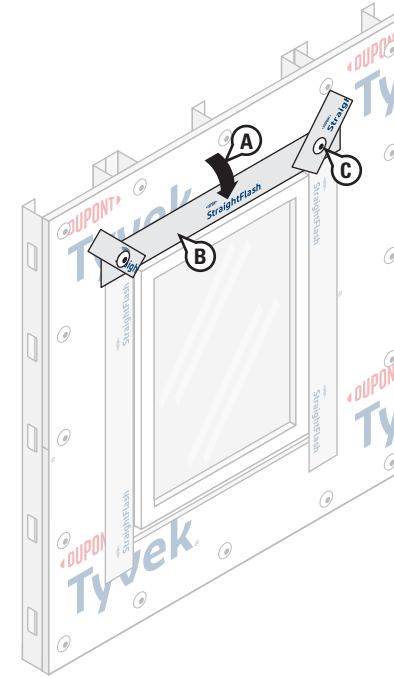
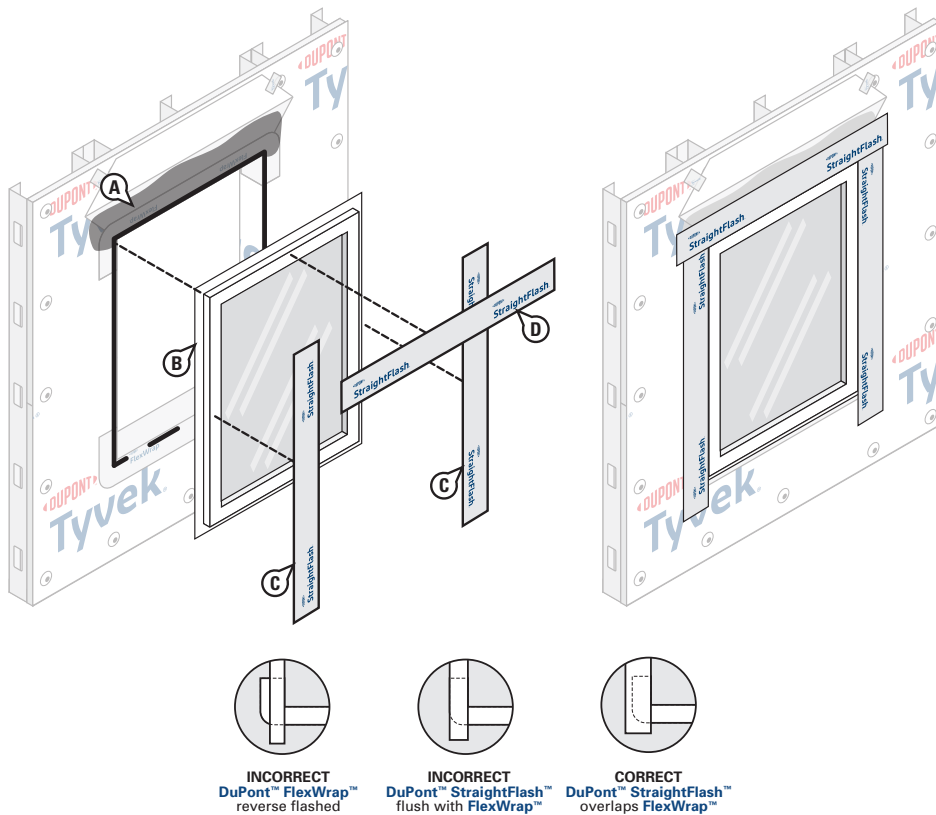

STEP 9

- Apply a recommended adhesive/primer to exposed sheathing. Refer to [Chemical Compatibility of Representative Building Sealants and Adhesives/Primers](#) for more information on recommended adhesives/primers.
- Install window according to manufacturer's instructions.
- Cut two pieces of DuPont™ StraightFlash™ or DuPont™ Flashing Tape* for jamb flashing extending 1" above window head flange and 2" to 4" below bottom edge of sill flashing. Remove release paper and press tightly along sides of window frame.
- Cut a piece of StraightFlash™ or DuPont™ Flashing Tape* for head flashing, which extends 1" **BEYOND** the outer edges of jamb flashings. Remove release paper and install completely covering mounting flange and adhering to exposed sheathing or framing members.

STEP 10

- Flip down upper flap of Tyvek® WRB so it lays flat across head flashing, then trim **1"– 2" above the window opening**.
- Starting along the horizontal, terminate the head flap with 4" DuPont™ StraightFlash™. (See [Special Considerations](#) for allowances for using 4" DuPont™ Flashing Tape or 3" Tyvek® Tape in lieu of StraightFlash™).
- Install DuPont™ Tyvek® Wrap Cap Fasteners or recommended fasteners at appropriate spacing at head.

NOTE: For a more robust install, areas with extreme wind load exposures, or high performance testing use 4" StraightFlash™ to seal the head flap and install additional mechanical fasteners through the flashing at the head flap and perimeter of window.

*DuPont™ Flashing Tape is only permitted for Residential-Use building structures. Residential-Use (Group R) is defined by the 2018/2021 International Building Code.

Installation Methods for DuPont Self-Adhered Flashing Products Installed **AFTER** the DuPont™ Tyvek® WRB Integral Flanged Window with DuPont™ FlexWrap™ along the Rough Opening Head

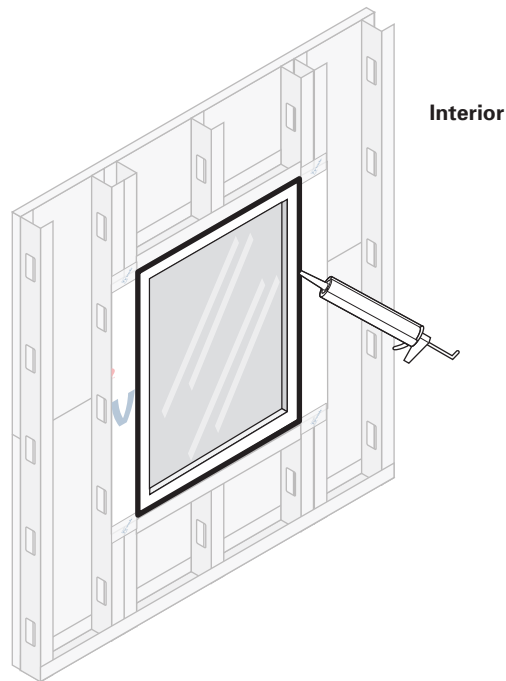

STEP 10

Final Step

Create a continuous perimeter seal using backer rod and recommended sealant or **Great Stuff Pro™ Window and Door Polyurethane Foam Sealant** on window interior to resist air and water infiltration. When using **Great Stuff Pro™ Window and Door Polyurethane Foam Sealant** in perimeter openings less than 1/2", apply using the plastic extension tip for the **Great Stuff Pro™ Dispenser Gun** during installation.

NOTE: For high performance installations exceeding ASTM E1677 wind loading pressures (10.8 psf, 65 mph equivalent structural load) and ASTM E331 water infiltration resistance of 6.24 psf, it is necessary to install sealant over the cured foam when using **Great Stuff Pro™ Window and Door Polyurethane Foam Sealant** or other recommended foam. Sealant should be installed over the foam between the window frame and rough opening around the entire interior perimeter. If **Great Stuff Pro™ Window and Door Polyurethane Foam Sealant** or other recommended foam extends **BEYOND** the window frame, shave the excess cured foam flush with the window frame before applying sealant. Avoid damaging the **DuPont Self-Adhered Flashing Product** or **DuPont™ Tyvek® WRB**.

Installation Methods for DuPont Self-Adhered Flashing Products Installed **AFTER** the DuPont™ Tyvek® WRB Alternate Integral Flanged Window Detail Aligned with FMA/AAMA 100-12 (Method A)

This method applies to the following products: DuPont™ StraightFlash™ and DuPont™ FlexWrap™

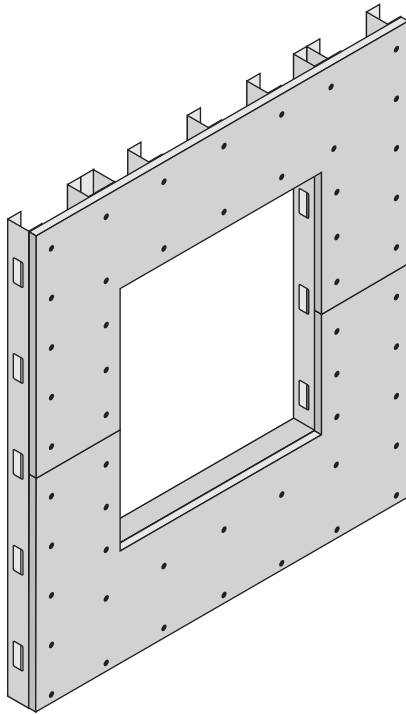

STEP 1

- A. Cut rough opening in sheathing for window. Ensure that sheathing is cut flush with, or slightly below the sill framing to allow for positive drainage.

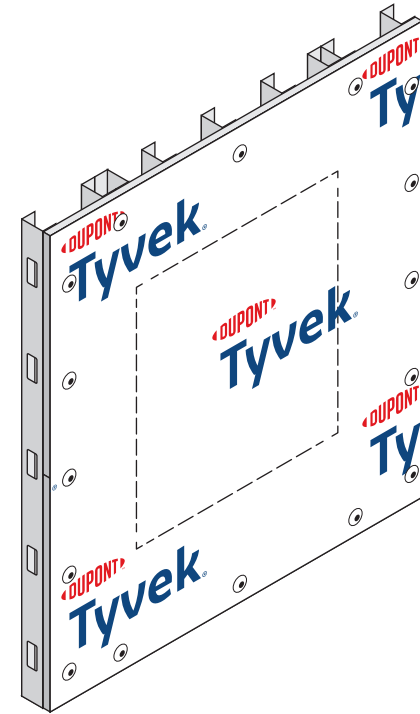

STEP 2

- A. Wrap wall as shown in the [DuPont™ Tyvek® WRB Installation Instructions](#) section in this guide. Do not install fasteners within 6" of the sills and jambs of the openings and within 9" of the head of the openings.

Installation Methods for DuPont Self-Adhered Flashing Products Installed **AFTER** the DuPont™ Tyvek® WRB Alternate Integral Flanged Window Detail Aligned with FMA/AAMA 100-12 (Method A)

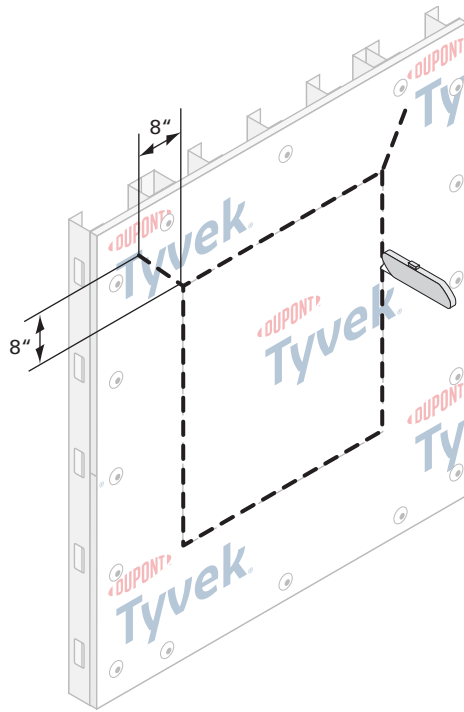

STEP 3

Prepare the Tyvek® WRB for Window Installation

- Cut an opening in the Tyvek® WRB using a square cut around the perimeter of the rough opening.
- Cuts should be made along the dashed indicated lines. (Ensure that the Tyvek® WRB is cut flush with the sheathing and is not wrapped into the rough opening.)
- Cut a head flap at a 45° angle to expose 8" of sheathing to allow for head flashing installation.

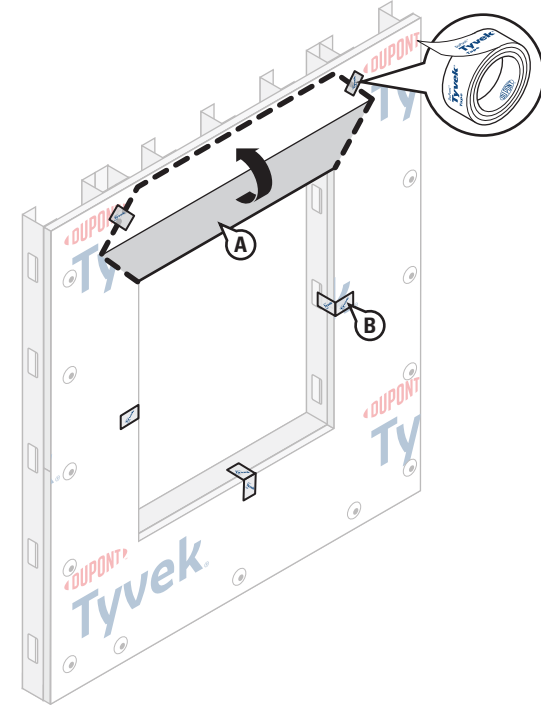

STEP 4

- Flip the head flap up to expose the sheathing and temporarily secure with tape.
- Temporarily secure Tyvek® WRB with DuPont™ Tyvek® Tape around rough opening before flashing is installed to help facilitate flashing installation.

Installation Methods for DuPont Self-Adhered Flashing Products Installed **AFTER** the DuPont™ Tyvek® WRB Alternate Integral Flanged Window Detail Aligned with FMA/AAMA 100-12 (Method A)

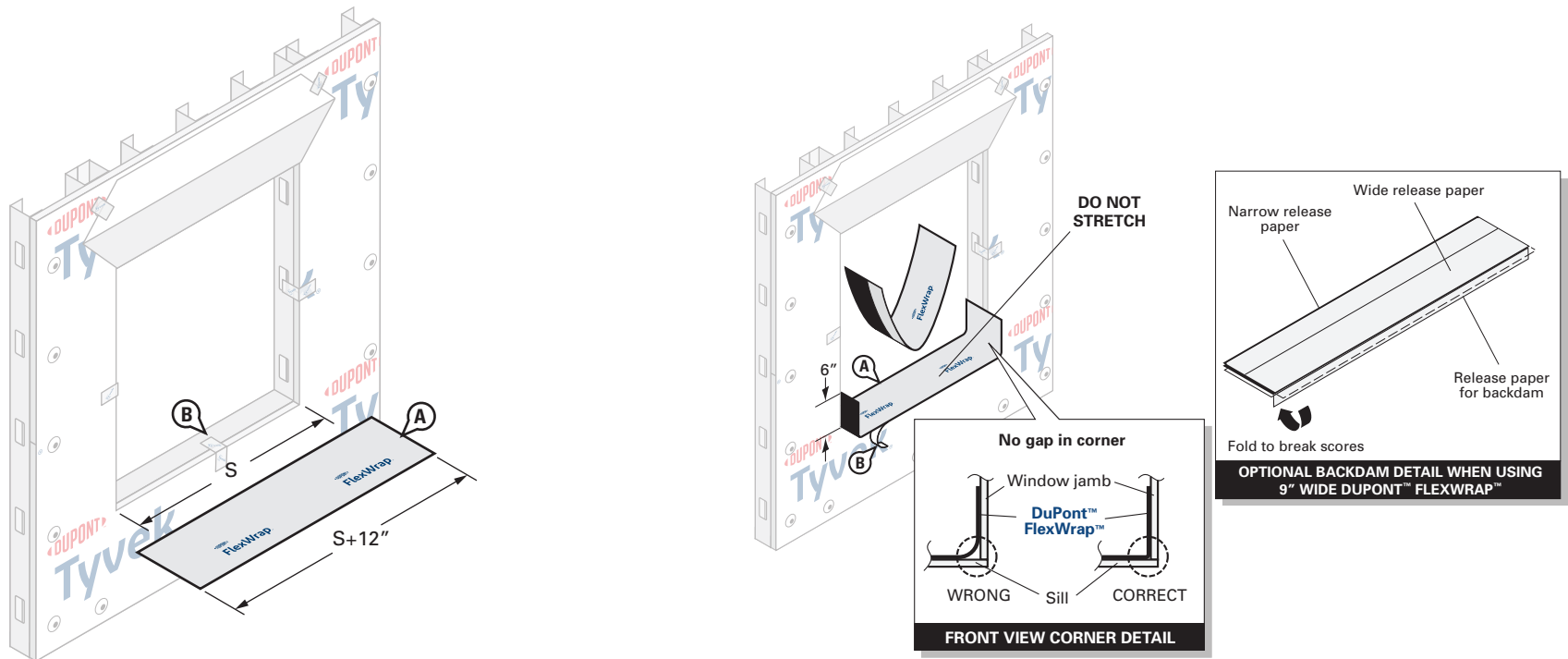

STEP 5

- A. Cut **DuPont™ FlexWrap™** at least 12" **LONGER** than the width of rough opening sill (S). Use roll widths sufficient to achieve a minimum of 1" adhesion **BEYOND** where the back of the window frame will be located, ensuring 2"– 3" adhesion onto the face of the wall.
- B. Inspect installation surface to ensure surface is free of dirt or substances that could interfere with adhesion as well as any sharp protrusions.

STEP 6

- A. Remove wide piece of release paper. Position on horizontal sill by aligning the inside edge of the narrow release paper with the face of the wall to ensure 2"– 3" of the **FlexWrap™** will be adhered to the face of the wall with a minimum of 6" up each jamb. Adhere into rough opening.

Optional Back Dam: Fold 9" **FlexWrap™** to break perforation. Remove center piece of release paper. Cover horizontal sill to accommodate back dam as appropriate, and adhere into rough opening along sill and up jambs (min 6" on each side). Leave 1" release paper on **FlexWrap™** inside rough opening to finish back dam after window installation.

- B. Remove narrow release paper.

NOTE: DuPont™ Tyvek® Commercial Certified Installers may install a 3-piece head (and sill) detail for window openings less than 6 ft. wide. Installers who **are not** DuPont™ Tyvek® Commercial Certified Installers should refer to the [Special Considerations](#) section for more information regarding the 3-piece head/sill detail. Contact your local DuPont Building Envelope Specialist for more information about the Certified Installer program.

Installation Methods for DuPont Self-Adhered Flashing Products Installed **AFTER** the DuPont™ Tyvek® WRB Alternate Integral Flanged Window Detail Aligned with FMA/AAMA 100-12 (Method A)

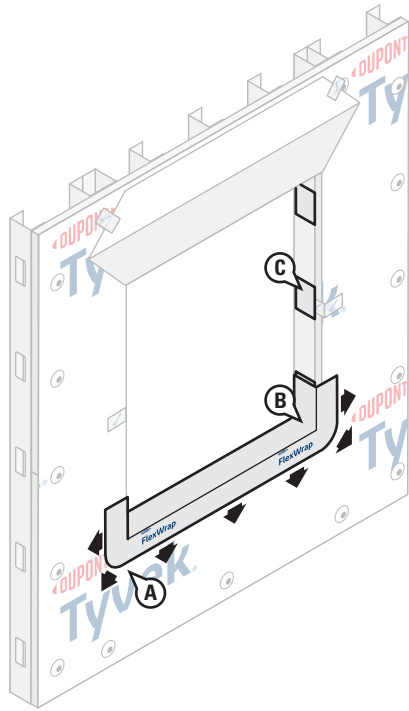

STEP 7

- A. Fan out the **DuPont™ FlexWrap™** at corners and adhere onto face of wall. Continue adhering onto face of wall along sill.
- B. Firmly press sill flashing to ensure full adhesion on all surfaces. Eliminate wrinkles and bubbles by smoothing surface and repositioning as necessary.
- C. Cover holes in studs with patches of **DuPont™ StraightFlash™** as necessary.

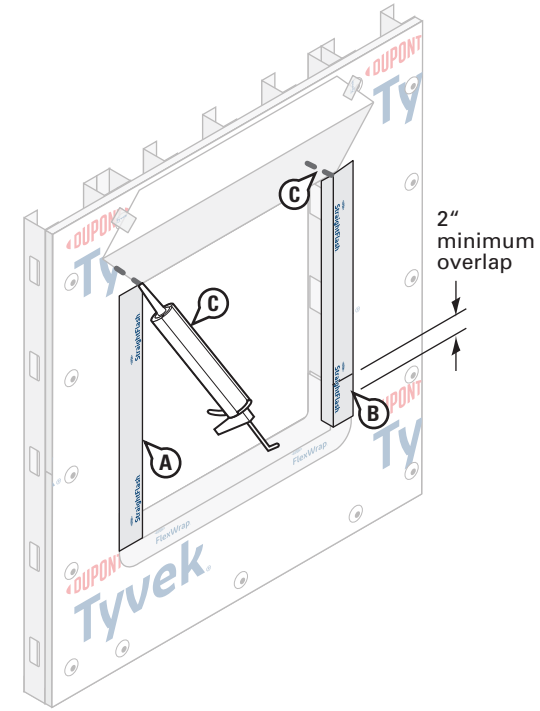

STEP 8

- A. Install 4" **DuPont™ StraightFlash™** into the rough opening at each jamb and onto wall face. The flashing does not need to align with the interior edge of the jamb framing. Cut the jamb flashing the vertical length of the rough opening.
- B. Jamb flashing should be long enough to overlap the sill flashing by at least 2" and be overlapped by future head flashing by at least 2".
- C. Apply sealant to inside corners of rough opening at jamb/head.

Installation Methods for DuPont Self-Adhered Flashing Products Installed AFTER the DuPont™ Tyvek® WRB Alternate Integral Flanged Window Detail Aligned with FMA/AAMA 100-12 (Method A)

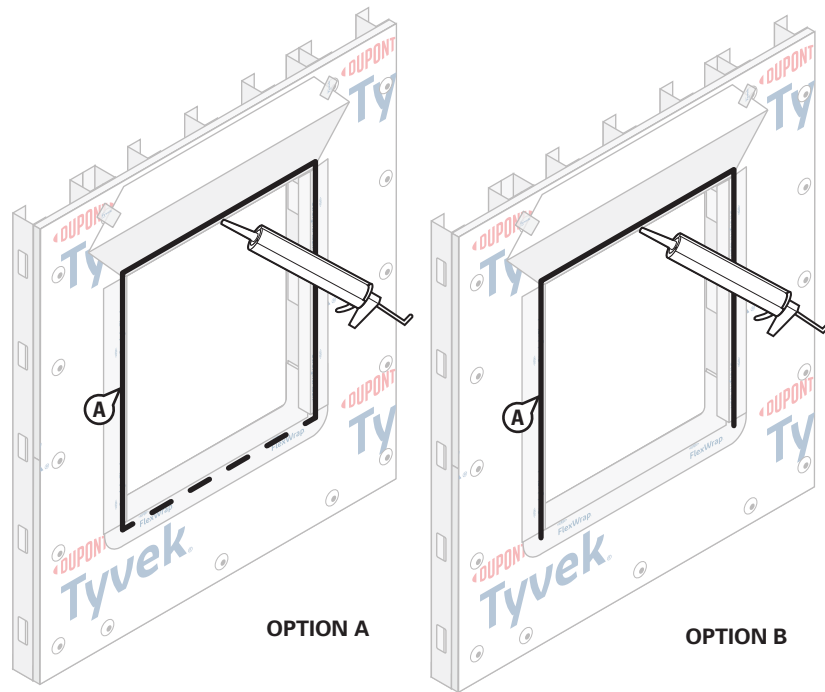

OPTION A

OPTION B

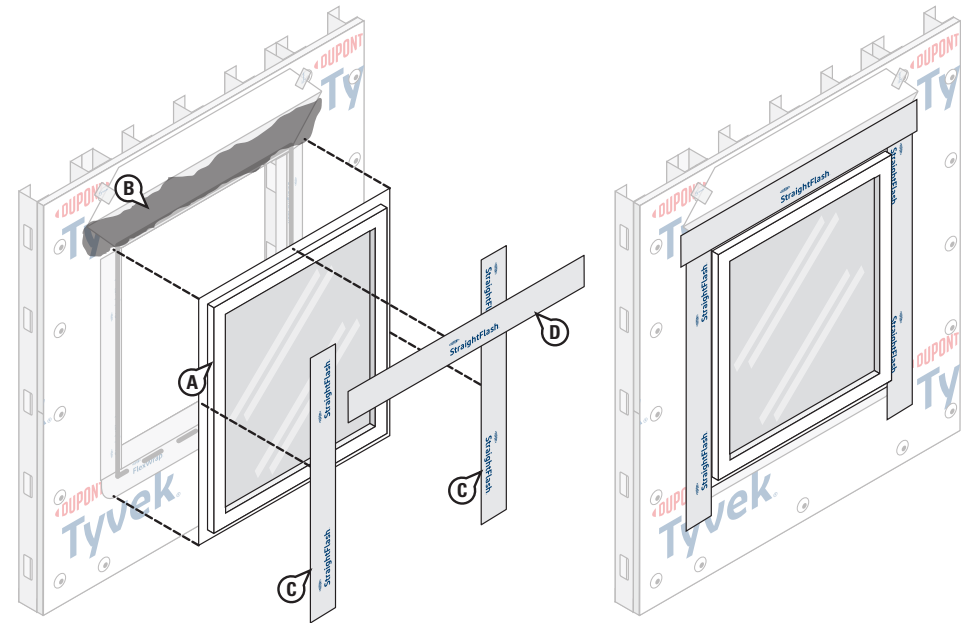

STEP 9

OPTION A: Apply a continuous bead of a recommended sealant at window head and jambs to wall or back side of window mounting flange. **To allow for drainage, do not apply continuous sealant bead along sill.** Ensure a minimum 2" wide drainage gap in the sealant bead within 4" from **each corner** of the jamb-sill interface. Continue applying sealant along the sill with additional 2" wide (min.) drainage gaps for every 6"- 12" (on center) of sill width. Refer to [Chemical Compatibility of Representative Building Sealants and Adhesives/Primers](#) for more information on recommended sealants.

OPTION B: Apply a continuous bead of a recommended sealant at window head and jambs to wall or back side of window mounting flange. **To allow for drainage, do not apply sealant bead along sill.**

STEP 10

- Install window according to manufacturer's instructions.
- Apply a recommended adhesive/primer to exposed sheathing. Refer to [Chemical Compatibility of Representative Building Sealants and Adhesives/Primers](#) for more information on recommended adhesives/primers.
- Cut two pieces of **DuPont™ StraightFlash™** or **DuPont™ Flashing Tape*** for jamb flashing extending 1" above window head flange and 2" to 4" below bottom edge of sill flashing. Remove release paper and press tightly along sides of window frame.
- Cut a piece of **StraightFlash™** or **DuPont™ Flashing Tape*** for head flashing, which extends 1" **BEYOND** the outer edges of jamb flashings. Remove release paper and install completely covering mounting flange and adhering to exposed sheathing or framing members.

*DuPont™ Flashing Tape is only permitted for Residential-Use building structures. Residential-Use (Group R) is defined by the 2018/2021 International Building Code.

Installation Methods for DuPont Self-Adhered Flashing Products Installed AFTER the DuPont™ Tyvek® WRB Alternate Integral Flanged Window Detail Aligned with FMA/AAMA 100-12 (Method A)

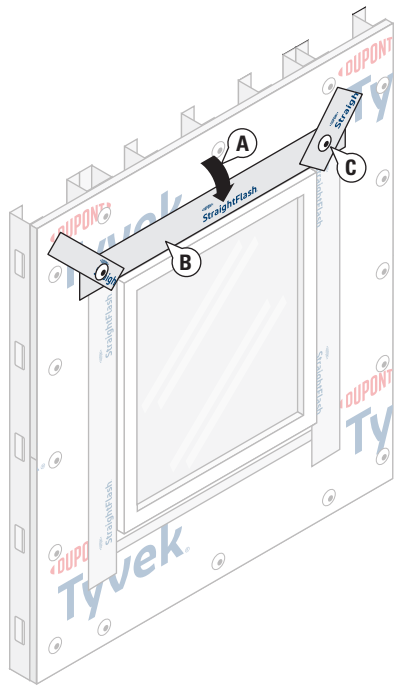

STEP 11

- Flip down upper flap of **Tyvek® WRB** so it lays flat across head flashing, then **trim 1"– 2" above the window opening**.
- Starting along the horizontal, terminate the head flap with 4" **DuPont™ StraightFlash™**. (See [Special Considerations](#) for allowances for using 4" **DuPont™ Flashing Tape** or 3" **Tyvek® Tape** in lieu of **StraightFlash™**).
- Install **DuPont™ Tyvek® Wrap Cap Fasteners** or recommended fasteners at appropriate spacing at head.

NOTE: For a more robust install, areas with extreme wind load exposures, or high performance testing use 4" **StraightFlash™** to seal the head flap and install additional mechanical fasteners through the flashing at the head flap and perimeter of window.

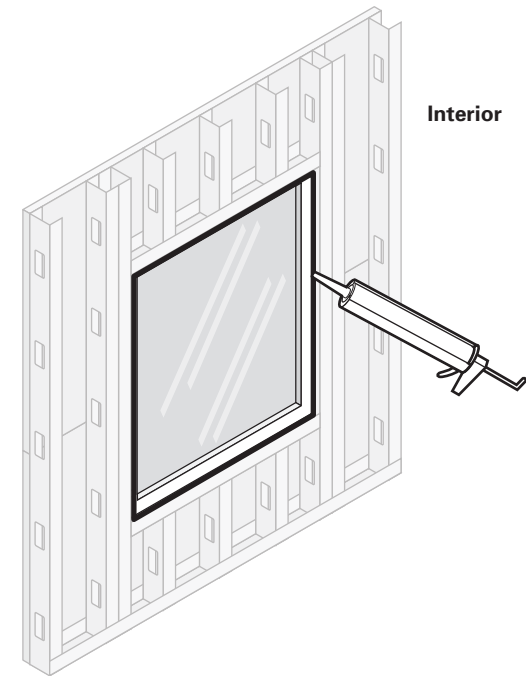

STEP 12

Final Step

Create a continuous perimeter seal using backer rod and recommended sealant or **Great Stuff Pro™ Window and Door Polyurethane Foam Sealant** on window interior to resist air and water infiltration. When using **Great Stuff Pro™ Window and Door Polyurethane Foam Sealant** in perimeter openings less than ½", apply using the plastic extension tip for the **Great Stuff Pro™ Dispenser Gun** during installation.

NOTE: For high performance installations exceeding ASTM E1677 wind loading pressures (10.8 psf, 65 mph equivalent structural load) and ASTM E331 water infiltration resistance of 6.24 psf, it is necessary to install sealant over the cured foam when using **Great Stuff Pro™ Window and Door Polyurethane Foam Sealant** or other recommended foam. Sealant should be installed over the foam between the window frame and rough opening around the entire interior perimeter. If **Great Stuff Pro™ Window and Door Polyurethane Foam Sealant** or other recommended foam extends **BEYOND** the window frame, shave the excess cured foam flush with the window frame before applying sealant. Avoid damaging the **DuPont Self-Adhered Flashing Product**.

*DuPont™ Flashing Tape is only permitted for Residential-Use building structures. Residential-Use (Group R) is defined by the 2018/2021 International Building Code.

Installation Methods for DuPont Self-Adhered Flashing Products Installed **AFTER** the DuPont™ Tyvek® WRB Alternate Integral Flanged Window Detail Aligned with FMA/AAMA 100-12 (Method B)

This method applies to the following products: DuPont™ StraightFlash™ and DuPont™ FlexWrap™

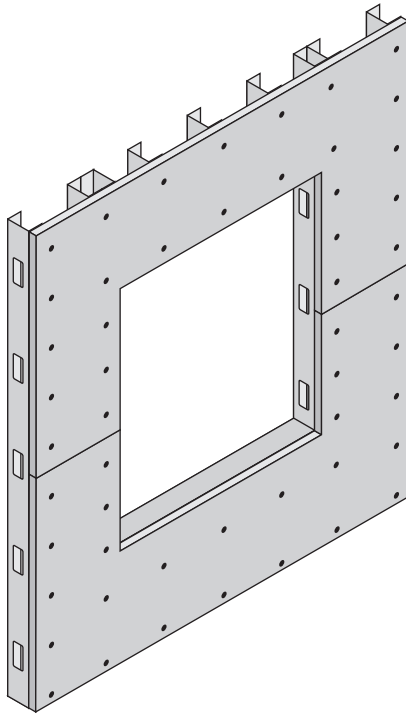

STEP 1

- A. Cut rough opening in sheathing for window. Ensure that sheathing is cut flush with, or slightly below the sill framing to allow for positive drainage.

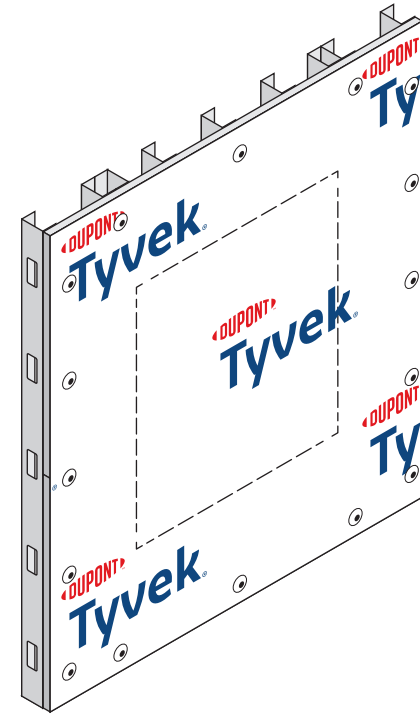

STEP 2

- A. Wrap wall as shown in the [DuPont™ Tyvek® WRB Installation Instructions](#) section in this guide. Do not install fasteners within 6" of the sills and jambs of the openings and within 9" of the head of the openings.

Installation Methods for DuPont Self-Adhered Flashing Products Installed AFTER the DuPont™ Tyvek® WRB Alternate Integral Flanged Window Detail Aligned with FMA/AAMA 100-12 (Method B)

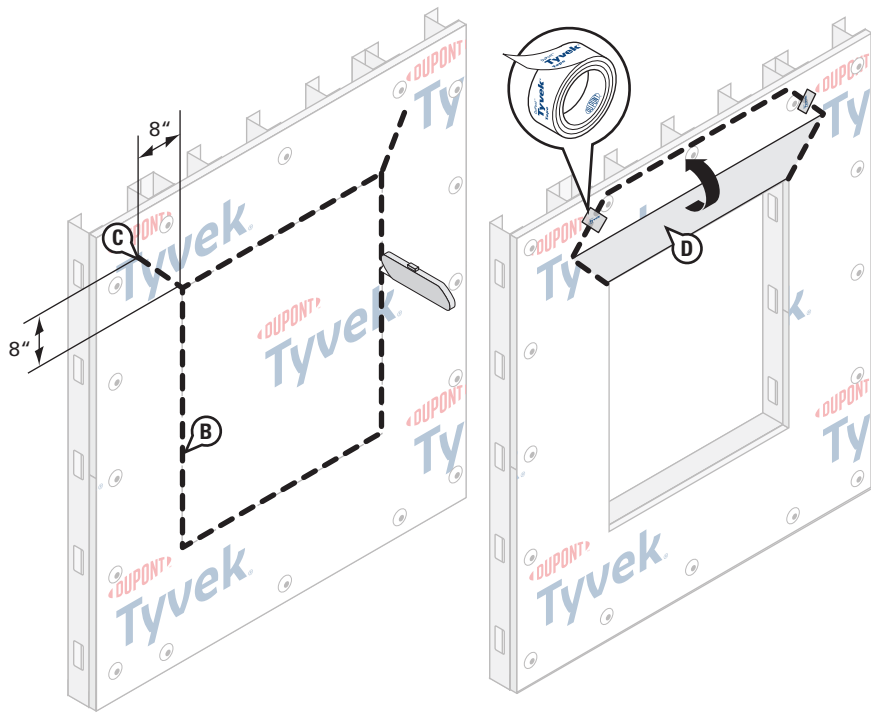

STEP 3

Prepare the Tyvek® WRB for Window Installation

- Cut an opening in the Tyvek® WRB using a square cut around the perimeter of the rough opening.
- Cuts should be made along the dashed indicated lines. (Ensure that the Tyvek® WRB is cut flush with the sheathing and is not wrapped into the rough opening.)
- Cut a head flap at a 45° angle to expose 8" of sheathing to allow for head flashing installation.
- Flip the head flap up to expose the sheathing and temporarily secure with DuPont™ Tyvek® Tape.

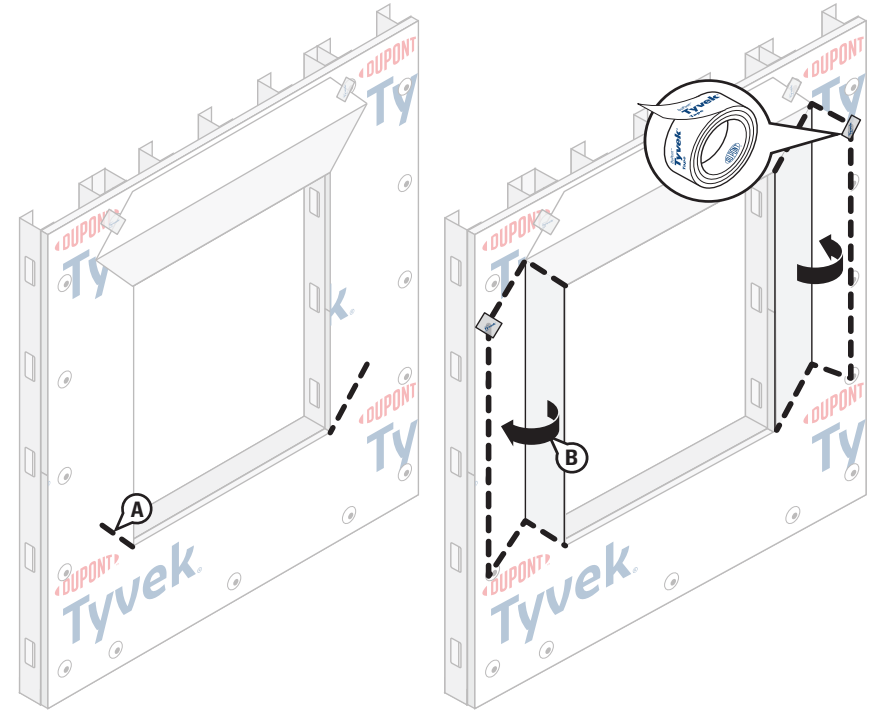

STEP 4

- Cut two 45° slits extending from the bottom corner up and away from the window opening to expose approximately 8" of sheathing. This will create a flap at each jamb to allow for jamb flashing installation.
- Flip the flaps to the side to expose the sheathing and temporarily secure with Tyvek® Tape.

Installation Methods for DuPont Self-Adhered Flashing Products Installed AFTER the DuPont™ Tyvek® WRB Alternate Integral Flanged Window Detail Aligned with FMA/AAMA 100-12 (Method B)

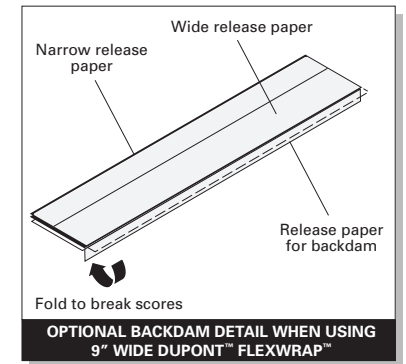
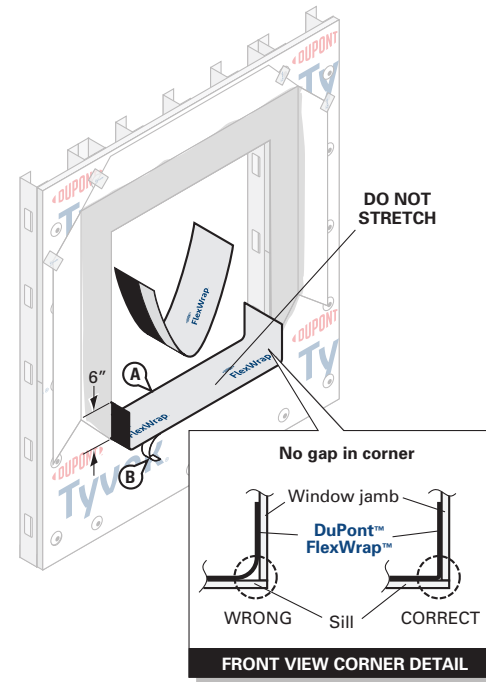
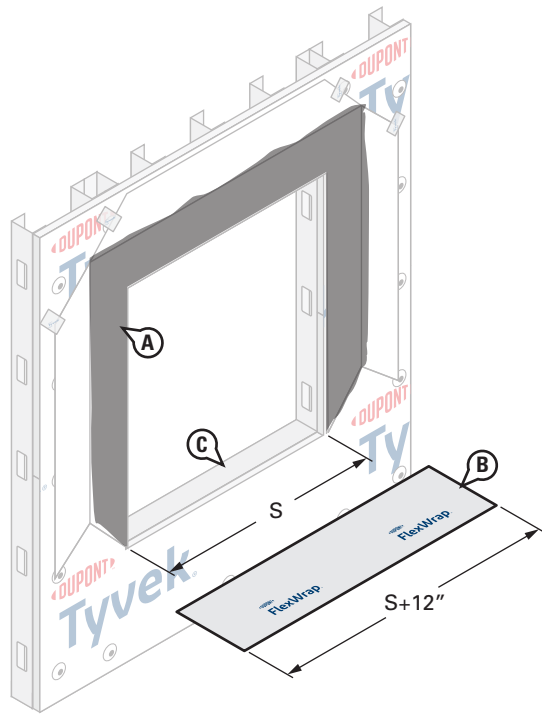

STEP 5

- Apply a recommended adhesive/primer to exposed sheathing at jambs and head. Refer to [Chemical Compatibility of Representative Building Sealants and Adhesives/Primers](#) for more information on recommended adhesives/primers.
- Cut **DuPont™ FlexWrap™** at least 12" **LONGER** than the width of rough opening sill (S). Use roll widths sufficient to achieve a minimum of 1" adhesion **BEYOND** where the back of the window frame will be located, ensuring 2"- 3" adhesion onto the face of the wall.
- Inspect installation surface to ensure surface is free of dirt or substances that could interfere with adhesion as well as any sharp protrusions.

STEP 6

- Remove wide piece of release paper. Position on horizontal sill by aligning the inside edge of the narrow release paper with the face of the wall to ensure 2"- 3" of the **FlexWrap™** will be adhered to the face of the wall with a minimum of 6" up each jamb. Adhere into rough opening.

Optional Back Dam: Fold 9" **FlexWrap™** to break perforation. Remove center piece of release paper. Cover horizontal sill to accommodate back dam as appropriate, and adhere into rough opening along sill and up jambs (min 6" on each side). Leave 1" release paper on **FlexWrap™** inside rough opening to finish back dam after window installation.

- Remove narrow release paper.

NOTE: DuPont™ Tyvek® Commercial Certified Installers may install a 3-piece head (and sill) detail for window openings less than 6 ft. wide. Installers who **are not** DuPont™ Tyvek® Commercial Certified Installers should refer to the [Special Considerations](#) section for more information regarding the 3-piece head/sill detail. Contact your local DuPont Building Envelope Specialist for more information about the Certified Installer program.

Installation Methods for DuPont Self-Adhered Flashing Products Installed AFTER the DuPont™ Tyvek® WRB Alternate Integral Flanged Window Detail Aligned with FMA/AAMA 100-12 (Method B)

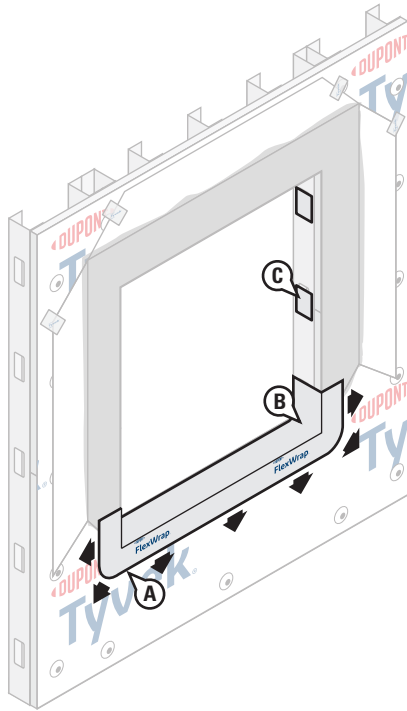

STEP 7

- Fan out the **DuPont™ FlexWrap™** at corners and adhere onto face of wall. Continue adhering onto face of wall along sill.
- Firmly press sill flashing to ensure full adhesion on all surfaces. Eliminate wrinkles and bubbles by smoothing surface and repositioning as necessary.
- Cover holes in studs with patches of **DuPont™ StraightFlash™** as necessary.

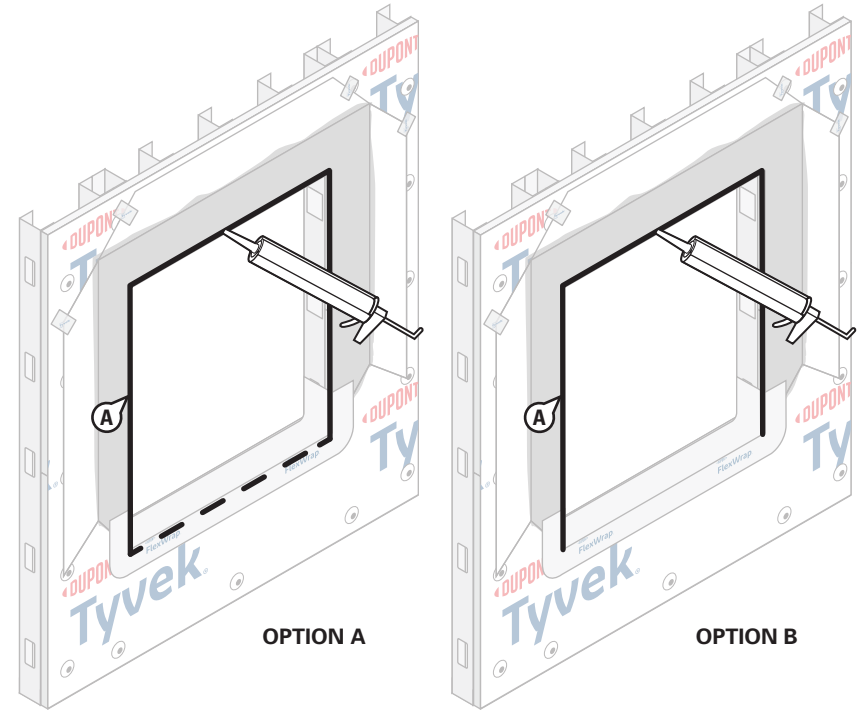

STEP 8

OPTION A: Apply a continuous bead of a recommended sealant at window head and jambs to wall or back side of window mounting flange. **To allow for drainage, do not apply continuous sealant bead along sill.** Ensure a minimum 2" wide drainage gap in the sealant bead within 4" from **each corner** of the jamb-sill interface. Continue applying sealant along the sill with additional 2" wide (min.) drainage gaps for every 6"- 12" (on center) of sill width. Refer to [Chemical Compatibility of Representative Building Sealants and Adhesives/Primers](#) for more information on recommended sealants.

OPTION B: Apply a continuous bead of a recommended sealant at window head and jambs to wall or back side of window mounting flange. **To allow for drainage, do not apply sealant bead along sill.**

Installation Methods for DuPont Self-Adhered Flashing Products Installed AFTER the DuPont™ Tyvek® WRB Alternate Integral Flanged Window Detail Aligned with FMA/AAMA 100-12 (Method B)

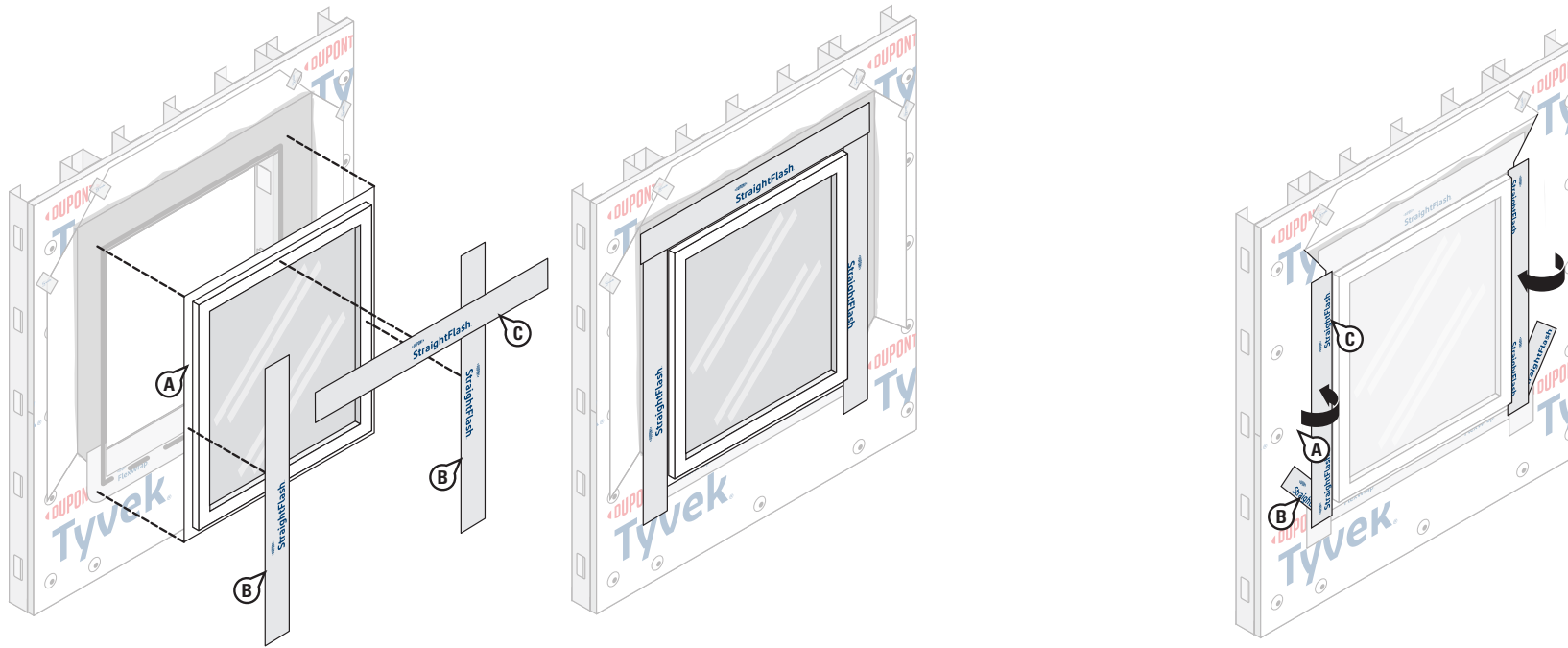

STEP 9

- Install window according to manufacturer's instructions.
- Cut two pieces of **DuPont™ StraightFlash™** or **DuPont™ Flashing Tape*** for jamb flashing extending 1" above window head flange and 4" to 6" below bottom edge of sill flashing. Remove release paper and press tightly along sides of window frame.
- Cut a piece of **StraightFlash™** or **DuPont™ Flashing Tape*** for head flashing, which extends **BEYOND** the outer edges of jamb flashings. Remove release paper and install completely covering mounting flange and adhering to exposed sheathing or framing members.

STEP 10

- Flip over flaps of **Tyvek® WRB** so each lays flat across jamb flashing, then **trim 1"– 2" from the window opening** using shears so as not to damage the **StraightFlash™** below.
- Starting at the bottom of the window, install 4" **StraightFlash™** along the angled cut in in the **Tyvek® WRB**. (See Special Consideration for when 3" **DuPont™ Tyvek® Tape** is allowed.)
- Install 4" **StraightFlash™** along the jamb flaps.
- Repeat on other side of window.

NOTE: For extreme wind load exposure and/or designated air barrier performance aligned with ASTM E2357 use 4" **StraightFlash™** to seal the head flap and install additional mechanical fasteners through the flashing at the head flap and perimeter of window.

*DuPont™ Flashing Tape is only permitted for Residential-Use building structures. Residential-Use (Group R) is defined by the 2018/2021 International Building Code.

Installation Methods for DuPont Self-Adhered Flashing Products Installed AFTER the DuPont™ Tyvek® WRB Alternate Integral Flanged Window Detail Aligned with FMA/AAMA 100-12 (Method B)

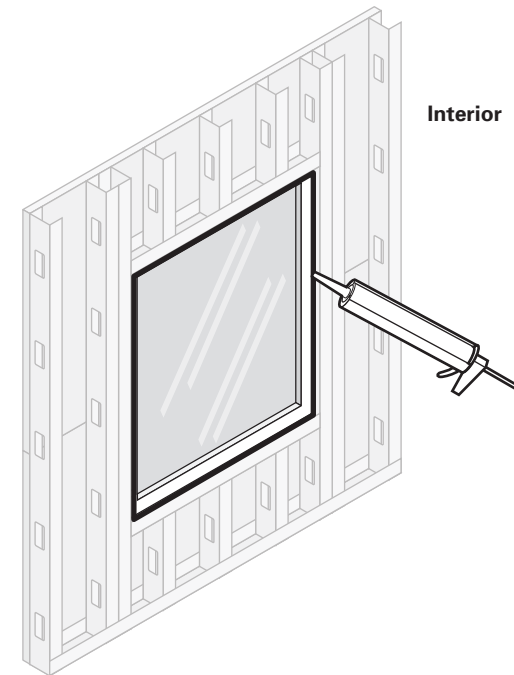
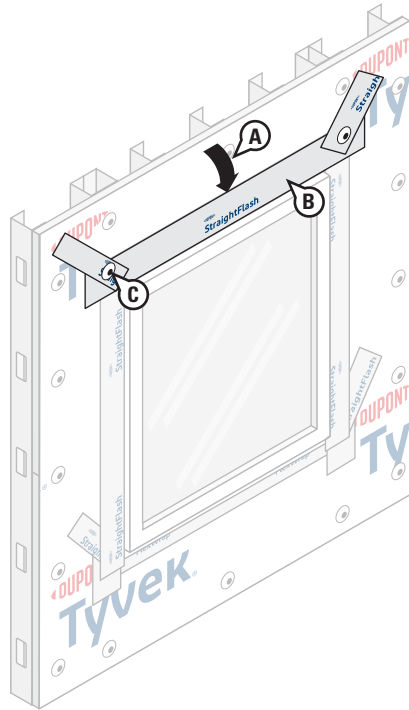

STEP 11

- Flip down upper flap of **Tyvek® WRB** so it lays flat across head flashing, then **trim 1"– 2" above the window opening**.
- Starting along the horizontal, terminate the head flap with 4" **DuPont™ StraightFlash™**. (See [Special Considerations](#) for allowances for using 4" **DuPont™ Flashing Tape** or 3" **Tyvek® Tape** in lieu of **StraightFlash™**).
- Install **DuPont™ Tyvek® Wrap Cap Fasteners** or recommended fasteners at appropriate spacing at head.

NOTE: For a more robust install, areas with extreme wind load exposures, or high performance testing use 4" **StraightFlash™** to seal the head flap and install additional mechanical fasteners through the flashing at the head flap and perimeter of window.

STEP 12

Final Step

Create a continuous perimeter seal using backer rod and recommend sealant or **Great Stuff Pro™ Window and Door Polyurethane Foam Sealant** on window interior to resist air and water infiltration. When using **Great Stuff Pro™ Window and Door Polyurethane Foam Sealant** in perimeter openings less than ½", apply using the plastic extension tip for the **Great Stuff Pro™ Dispenser Gun** during installation.

NOTE: For high performance installations exceeding ASTM E1677 wind loading pressures (10.8 psf, 65 mph equivalent structural load) and ASTM E331 water infiltration resistance of 6.24 psf, it is necessary to install sealant over the cured foam when using **Great Stuff Pro™ Window and Door Polyurethane Foam Sealant** or other recommended foam. Sealant should be installed over the foam between the window frame and rough opening around the entire interior perimeter. If **Great Stuff Pro™ Window and Door Polyurethane Foam Sealant** or other recommended foam extends **BEYOND** the window frame, shave the excess cured foam flush with the window frame before applying sealant. Avoid damaging the **DuPont Self-Adhered Flashing Product**.

*DuPont™ Flashing Tape is only permitted for Residential-Use building structures. Residential-Use (Group R) is defined by the 2018/2021 International Building Code.

Installation Methods for DuPont Self-Adhered Flashing Products Installed **AFTER** the DuPont™ Tyvek® WRB Alternate Integral Flanged Window Detail Aligned with FMA/AAMA 100-12 (Method C)

This method applies to the following products: DuPont™ StraightFlash™ and DuPont™ FlexWrap™

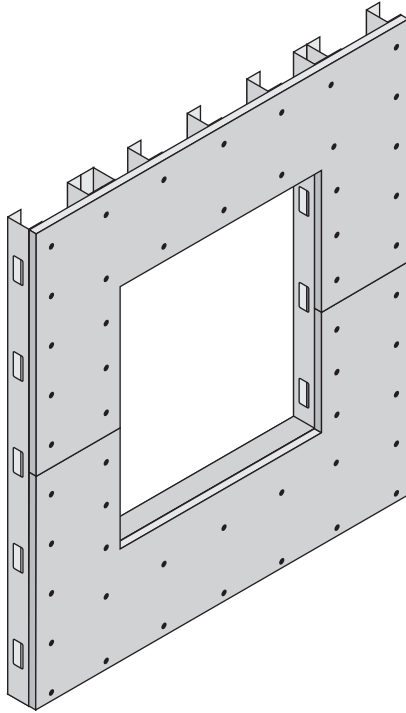

STEP 1

- A. Cut rough opening in sheathing for window. Ensure that sheathing is cut flush with, or slightly below the sill framing to allow for positive drainage.

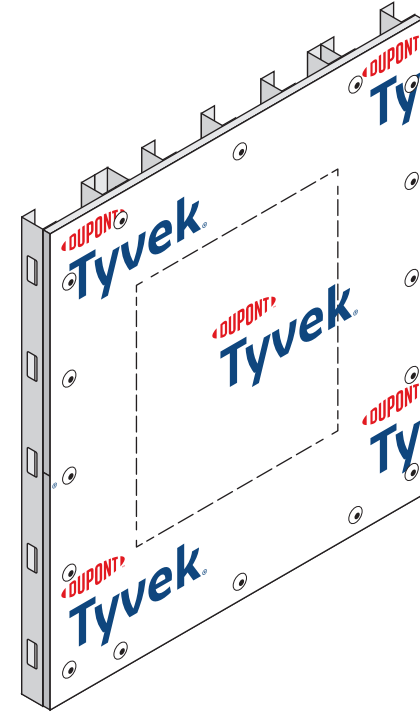

STEP 2

- A. Wrap wall as shown in the [DuPont™ Tyvek® WRB Installation Instructions](#) section in this guide. Do not install fasteners within 6" of the sills and jambs of the openings and within 9" of the head of the openings.

Installation Methods for DuPont Self-Adhered Flashing Products Installed AFTER the DuPont™ Tyvek® WRB Alternate Integral Flanged Window Detail Aligned with FMA/AAMA 100-12 (Method C)

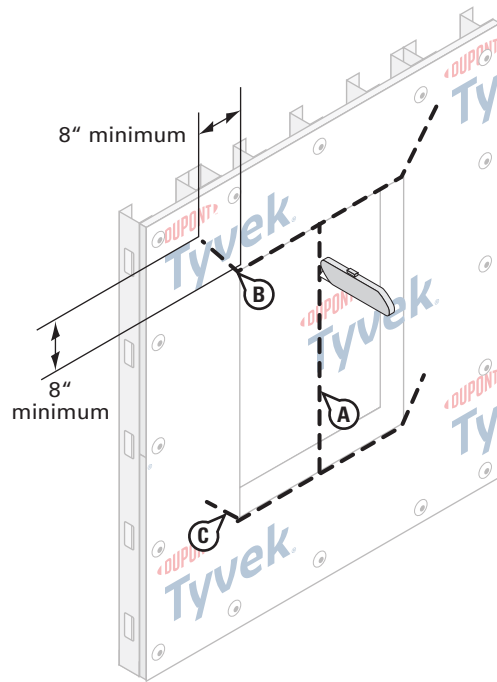

STEP 3

Prepare the Tyvek® WRB for Window Installation

- Make an "I-Cut" in the Tyvek® WRB. For an "I-Cut" begin with a horizontal cut across the bottom and the top of the window frame (for round top windows, cut from the center cut straight down to the sill).
- Cut a head flap at a 45° angle to expose 8" of sheathing to allow for head flashing installation.
- Cut two 45° slits extending from the bottom corner up and away from the window opening to expose 6"-8" of sheathing. This will create a flap at each jamb to allow for jamb flashing installation.

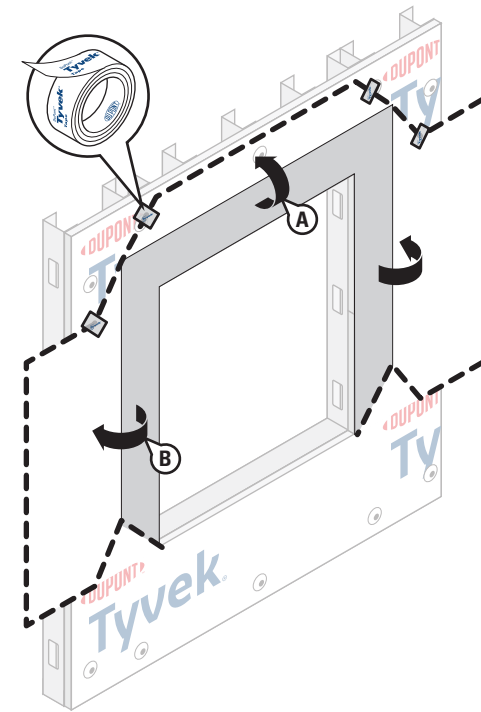

STEP 4

- Flip the head flap up to expose the sheathing and temporarily secure with DuPont™ Tyvek® Tape.
- Flip the flaps to the side to expose the sheathing and temporarily secure with Tyvek® Tape.

Installation Methods for DuPont Self-Adhered Flashing Products Installed **AFTER** the DuPont™ Tyvek® WRB Alternate Integral Flanged Window Detail Aligned with FMA/AAMA 100-12 (Method C)

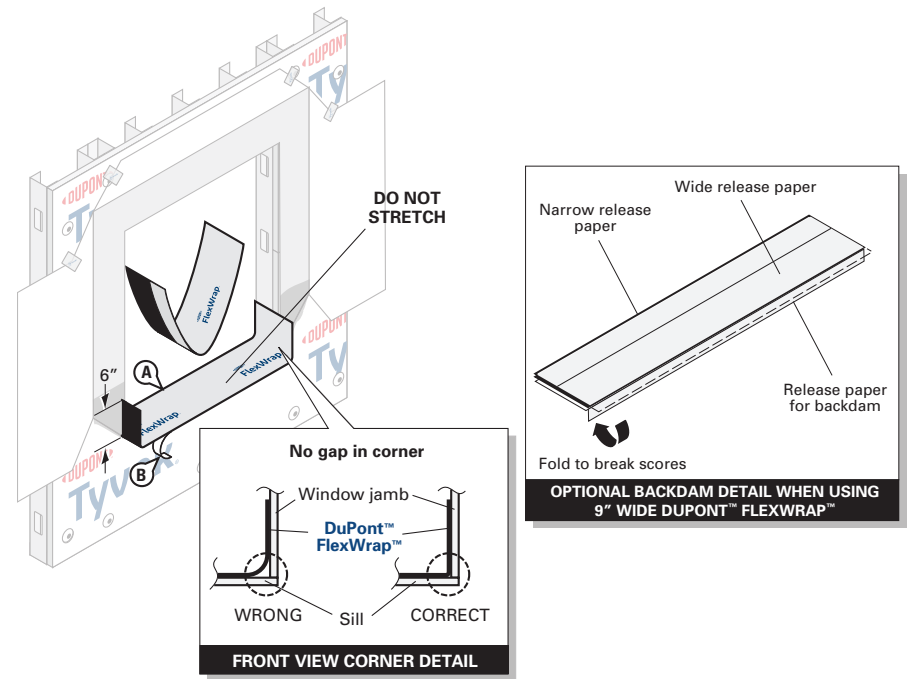
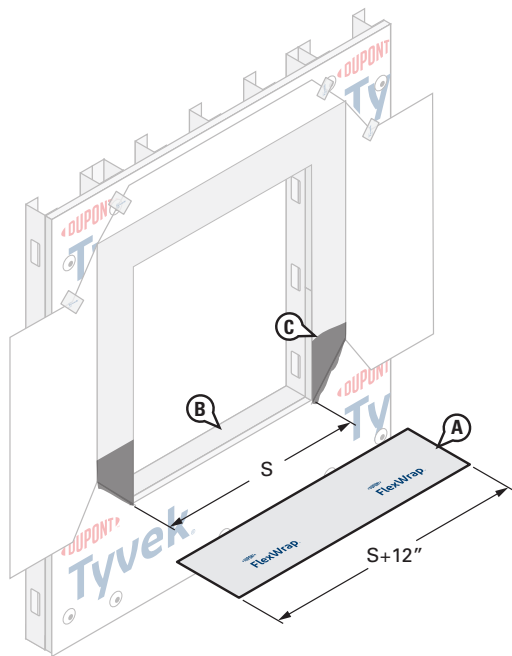

STEP 5

- Cut **DuPont™ FlexWrap™** at least 12" **LONGER** than the width of rough opening sill (S). Use roll widths sufficient to achieve a minimum of 1" adhesion **BEYOND** where the back of the window frame will be located, ensuring 2"– 3" adhesion onto the face of the wall.
- Inspect installation surface to ensure surface is free of dirt or substances that could interfere with adhesion as well as any sharp protrusions.
- Starting at the bottom corner, apply a recommended adhesive/primer to exposed sheathing at least 6" up the jamb. Refer to [Chemical Compatibility of Representative Building Sealants and Adhesives/Primers](#) for more information on recommended adhesives/primers.

STEP 6

- Remove wide piece of release paper. Position on horizontal sill by aligning the inside edge of the narrow release paper with the face of the wall to ensure 2"– 3" of the **FlexWrap™** will be adhered to the face of the wall with a minimum of 6" up each jamb. Adhere into rough opening.

Optional Back Dam: Fold 9" **FlexWrap™** to break perforation. Remove center piece of release paper. Cover horizontal sill to accommodate back dam as appropriate, and adhere into rough opening along sill and up jambs (min 6" on each side). Leave 1" release paper on **FlexWrap™** inside rough opening to finish back dam after window installation.

- Remove narrow release paper.

NOTE: DuPont™ Tyvek® Commercial Certified Installers may install a 3-piece head (and sill) detail for window openings less than 6 ft. wide. Installers who **are not** DuPont™ Tyvek® Commercial Certified Installers should refer to the [Special Considerations](#) section for more information regarding the 3-piece head/sill detail. Contact your local DuPont Building Envelope Specialist for more information about the Certified Installer program.

Installation Methods for DuPont Self-Adhered Flashing Products Installed AFTER the DuPont™ Tyvek® WRB Alternate Integral Flanged Window Detail Aligned with FMA/AAMA 100-12 (Method C)

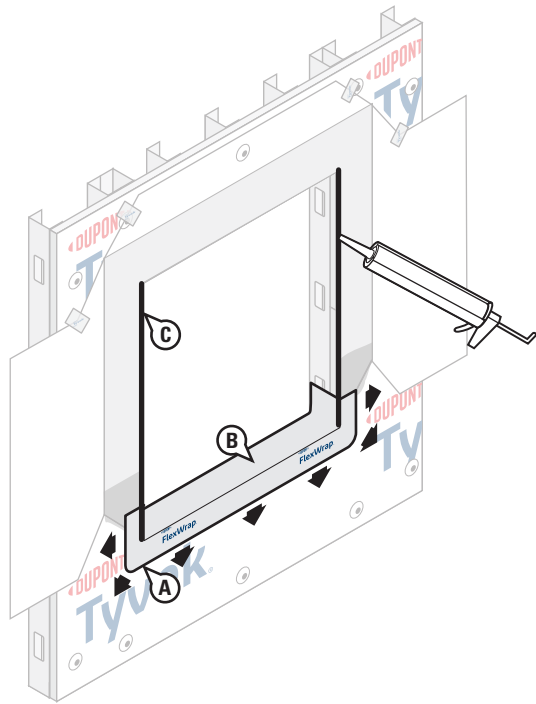

STEP 7

- A. Fan out the **DuPont™ FlexWrap™** at corners and adhere onto face of wall. Continue adhering onto face of wall along sill.
- B. Firmly press sill flashing to ensure full adhesion on all surfaces. Eliminate wrinkles and bubbles by smoothing surface and repositioning as necessary.
- C. Apply continuous bead of of recommended sealant. to wall at the window jambs. Refer to [Chemical Compatibility of Representative Building Sealants and Adhesives/Primers](#) for more information on recommended sealants.

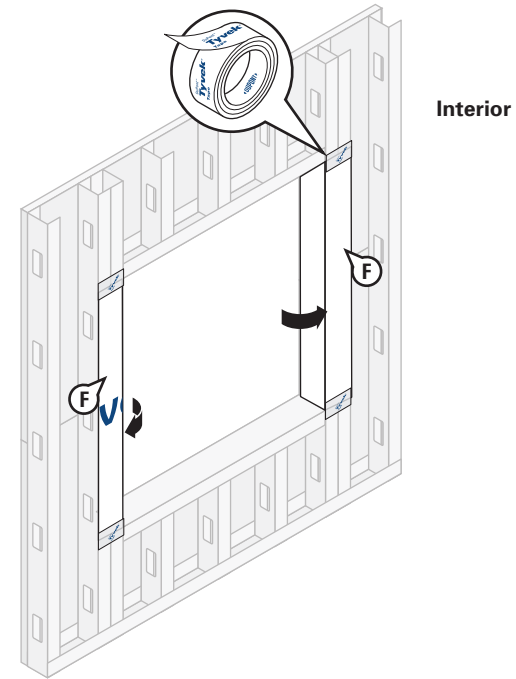

STEP 8

- A. Fold side flaps into rough opening, cut excess flaps, and secure secure with 3" **DuPont™ Tyvek® Tape**, **DuPont™ Flashing Tape*** or 4" **DuPont™ StraightFlash™**.

***DuPont™ Flashing Tape** is only permitted for Residential-Use building structures. Residential-Use (Group R) is defined by the 2015/2018 International Building Code.

Installation Methods for DuPont Self-Adhered Flashing Products Installed AFTER the DuPont™ Tyvek® WRB Alternate Integral Flanged Window Detail Aligned with FMA/AAMA 100-12 (Method C)

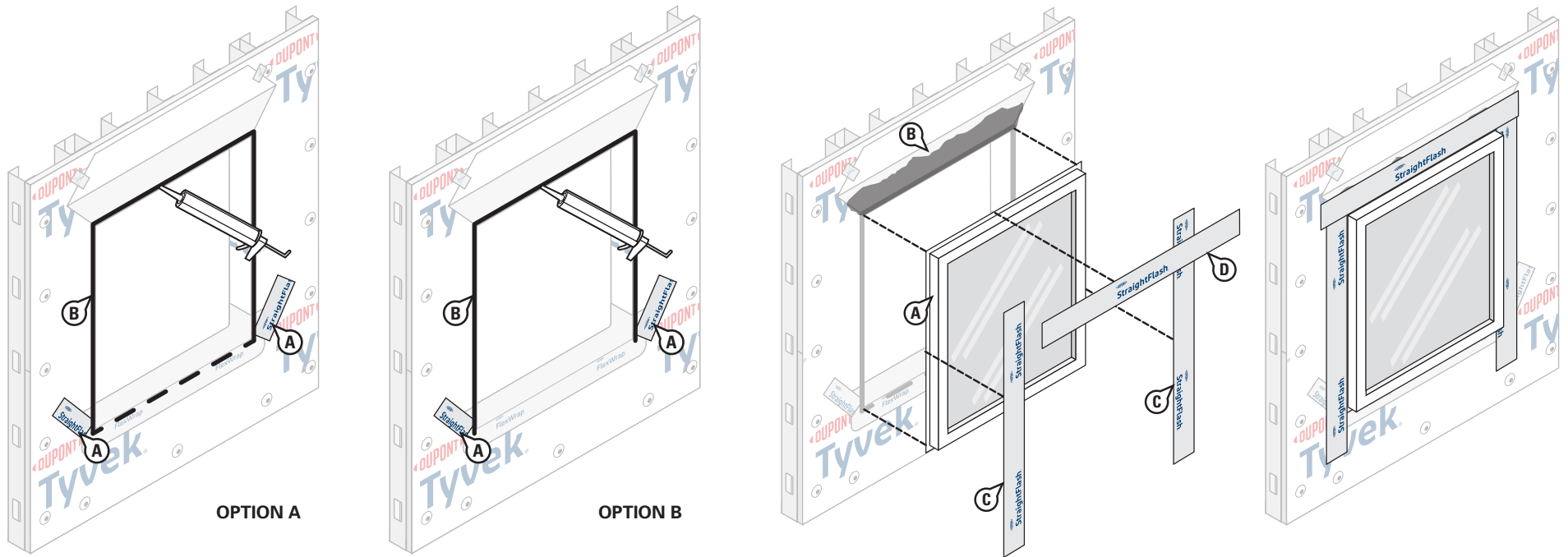

STEP 9

A. Starting at the bottom of the window, install 4" **DuPont™ StraightFlash™** or **DuPont™ Flashing Tape*** along the angled cut in in the **Tyvek® WRB**.

OPTION A: Apply a continuous bead of a recommended sealant at window head and jambs to wall or back side of window mounting flange. **To allow for drainage, do not apply continuous sealant bead along sill.** Ensure a minimum 2" wide drainage gap in the sealant bead within 4" from **each corner** of the jamb-sill interface. Continue applying sealant along the sill with additional 2" wide (min.) drainage gaps for every 6"– 12" (on center) of sill width. Refer to [Chemical Compatibility of Representative Building Sealants and Adhesives/Primers](#) for more information on recommended sealants.

OPTION B: Apply a continuous bead of a recommended sealant at window head and jambs to wall or back side of window mounting flange. **To allow for drainage, do not apply sealant bead along sill.**

STEP 10

A. Install window according to manufacturer's instructions.

B. Apply a recommended adhesive/primer to exposed sheathing. Refer to [Chemical Compatibility of Representative Building Sealants and Adhesives/Primers](#) for more information on recommended adhesives/primers.

C. Cut two pieces of **DuPont™ StraightFlash™** or **DuPont™ Flashing Tape*** for jamb flashing extending 1" above window head flange and 2" to 4" below bottom edge of sill flashing. Remove release paper and press tightly along sides of window frame.

D. Cut a piece of **StraightFlash™** or **DuPont™ Flashing Tape*** for head flashing, which extends **BEYOND** the outer edges of jamb flashings. Remove release paper and install completely covering mounting flange and adhering to exposed sheathing or framing members.

*DuPont™ Flashing Tape is only permitted for Residential-Use building structures. Residential-Use (Group R) is defined by the 2018/2021 International Building Code.

Installation Methods for DuPont Self-Adhered Flashing Products Installed AFTER the DuPont™ Tyvek® WRB Alternate Integral Flanged Window Detail Aligned with FMA/AAMA 100-12 (Method C)

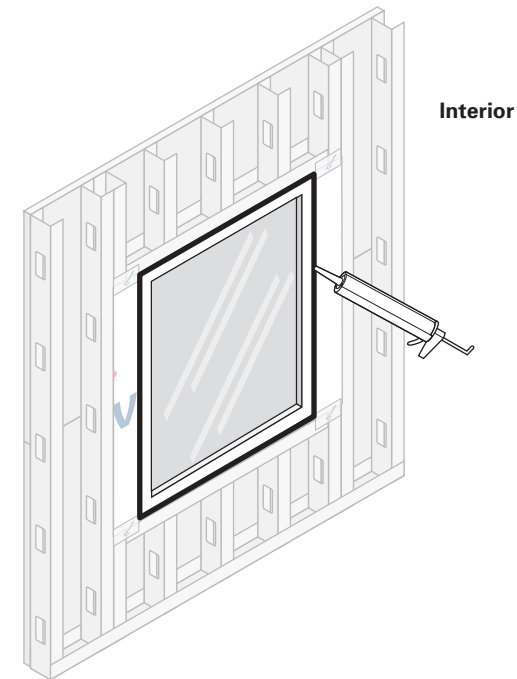
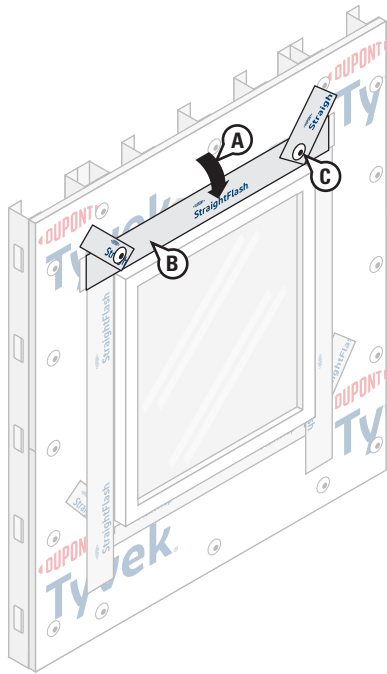

STEP 11

- Flip down upper flap of **Tyvek® WRB** so it lays flat across head flashing, then **trim 1"– 2" above the window opening**.
- Starting along the horizontal, terminate the head flap with 4" **DuPont™ StraightFlash™**. (See [Special Considerations](#) for allowances for using 4" **DuPont™ Flashing Tape** or 3" **Tyvek® Tape** in lieu of **StraightFlash™**).
- Install **DuPont™ Tyvek® Wrap Cap Fasteners** or recommended fasteners at appropriate spacing at head.

NOTE: For a more robust install, areas with extreme wind load exposures, or high performance testing use 4" **StraightFlash™** to seal the head flap and install additional mechanical fasteners through the flashing at the head flap and perimeter of window.

STEP 12

Final Step

Create a continuous perimeter seal using backer rod and recommended sealant or **Great Stuff Pro™ Window and Door Polyurethane Foam Sealant** on window interior to resist air and water infiltration. When using **Great Stuff Pro™ Window and Door Polyurethane Foam Sealant** in perimeter openings less than ½", apply using the plastic extension tip for the **Great Stuff Pro™ Dispenser Gun** during installation.

NOTE: For high performance installations exceeding ASTM E1677 wind loading pressures (10.8 psf, 65 mph equivalent structural load) and ASTM E331 water infiltration resistance of 6.24 psf, it is necessary to install sealant over the cured foam when using **Great Stuff Pro™ Window and Door Polyurethane Foam Sealant** or other recommended foam. Sealant should be installed over the foam between the window frame and rough opening around the entire interior perimeter. If **Great Stuff Pro™ Window and Door Polyurethane Foam Sealant** or other recommended foam extends **BEYOND** the window frame, shave the excess cured foam flush with the window frame before applying sealant. Avoid damaging the **DuPont Self-Adhered Flashing Product** or **DuPont™ Tyvek® WRB**.

*DuPont™ Flashing Tape is only permitted for Residential-Use building structures. Residential-Use (Group R) is defined by the 2018/2021 International Building Code.

Installation Methods for DuPont Self-Adhered Flashing Products Installed **AFTER** the DuPont™ Tyvek® WRB

Drip Cap Installation for Windows and Doors

Option 1

This option may be used for integral flanged, brick mold, field applied flanged, and non-flanged windows and doors. A drip cap can be installed over the head flashing above the window head **BEFORE** the Tyvek® WRB head flap is flipped down and sealed.

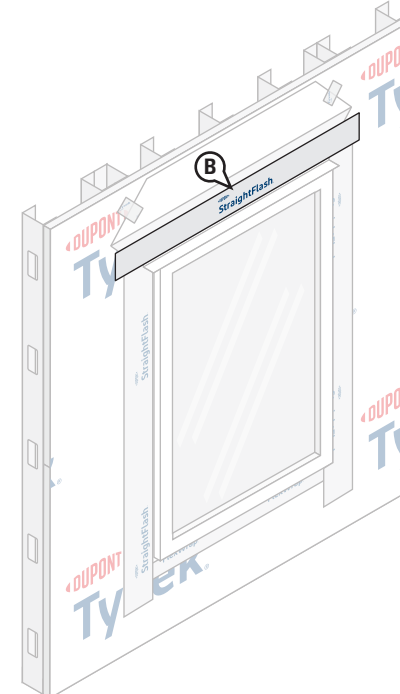
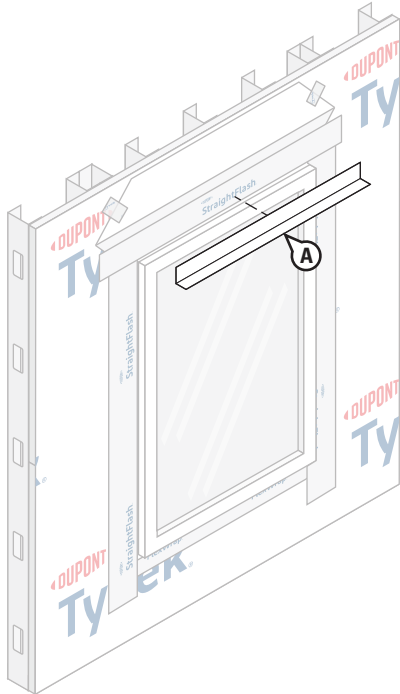

STEP 1

- A. After the head flashing is installed in accordance with these guidelines for the particular window type, (e.g. **DuPont™ StraightFlash™** or **DuPont™ Flashing Tape*** is installed over window head flange), cut metal or vinyl drip cap slightly **LONGER** than the width of the window.
- B. Install the drip cap tight against the window head flashing and cover the top edge with **StraightFlash™** or **DuPont™ Flashing Tape*** extending past the top and sides of the drip cap.

*DuPont™ Flashing Tape is only permitted for Residential-Use building structures. Residential-Use (Group R) is defined by the 2018/2021 International Building Code.

Installation Methods for DuPont Self-Adhered Flashing Products Installed AFTER the DuPont™ Tyvek® WRB

Drip Cap Installation for Windows and Doors

Option 1 (continued)

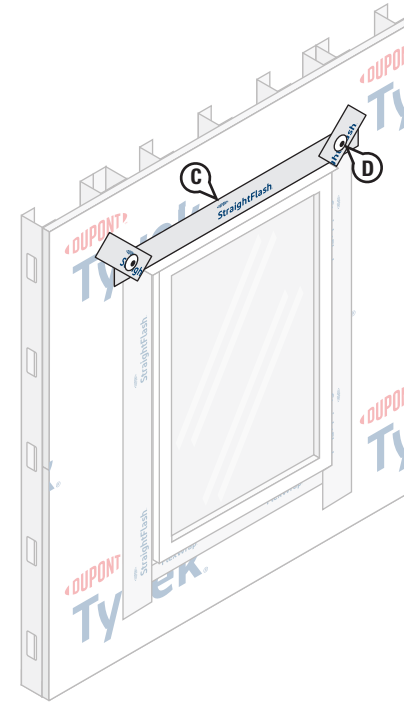
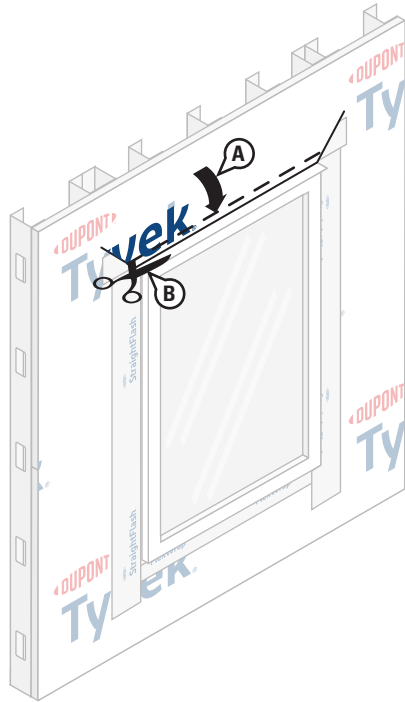

STEP 2

- A. Flip down **Tyvek® WRB** head flap so it lays flat across the **DuPont™ Flashing Tape*** or **DuPont™ StraightFlash™** covering the drip cap.
- B. Cut a 1"–2" strip of the **Tyvek® WRB** at lower horizontal edge of head flap.

- C. Starting along the horizontal, terminate the head flap with 4" **DuPont™ StraightFlash™**. (See [Special Considerations](#) for allowances for using 4" **DuPont™ Flashing Tape** or 3" **Tyvek® Tape** in lieu of **StraightFlash™**).
- D. Install **DuPont™ Tyvek® Wrap Cap Fasteners** or recommended fasteners at appropriate spacing at head.

NOTE: For a more robust install, areas with extreme wind load exposures, or high performance testing use 4" **StraightFlash™** to seal the head flap and install additional mechanical fasteners through the flashing at the head flap and perimeter of window.

***DuPont™ Flashing Tape** is only permitted for Residential-Use building structures. Residential-Use (Group R) is defined by the 2018/2021 International Building Code.

Installation Methods for DuPont Self-Adhered Flashing Products Installed AFTER the DuPont™ Tyvek® WRB

Drip Cap Installation for Windows and Doors

Option 2

This option applies to integral flanged windows and doors only. A drip cap with a short vertical leg can be installed at the window head flange so it is integrated with the **DuPont Self-Adhered Flashing Product** installed at the head of the window **BEFORE** the **DuPont™ Tyvek® WRB** head flap is flipped down and sealed. **NOTE:** When using this method, the vertical leg of the drip cap **must not be taller** than the window head flange when installed.

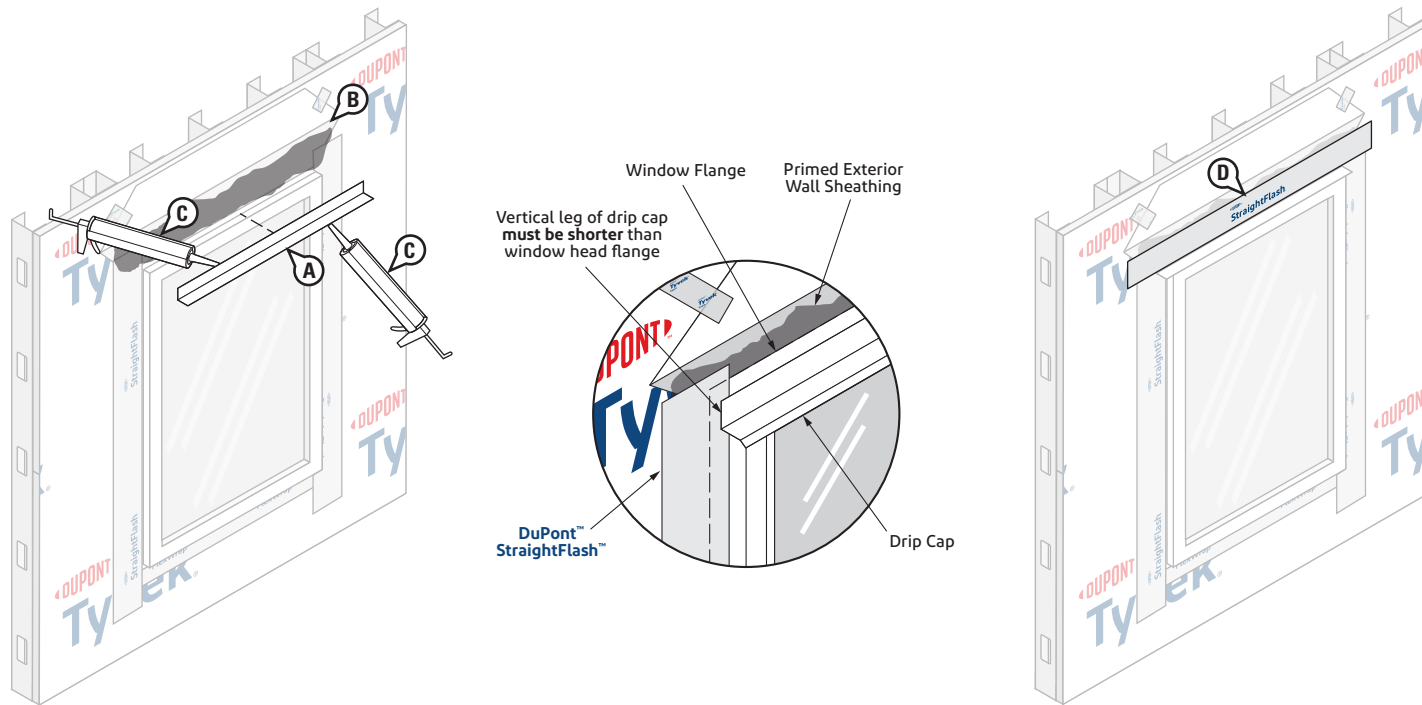

STEP 1

- After the window is installed and jamb flashing applied, cut a piece of metal or vinyl drip cap slightly **LONGER** than the width of the window.
- Apply a recommended adhesive/primer to exposed sheathing. Refer to [Chemical Compatibility of Representative Building Sealants and Adhesives/Primers](#) for more information on recommended adhesives/primers.
- Place a bead of recommended sealant on the rear side of the vertical leg **AND** a bead on the rear side of the bottom horizontal leg. Install the drip cap tight against the window head flange. Refer to [Chemical Compatibility of Representative Building Sealants and Adhesives/Primers](#) for more information on recommended sealants.
- Cover the head flange and top edge of the drip cap with a piece of **StraightFlash™** or **DuPont™ Flashing Tape**. The **DuPont Self-Adhered Flashing Product** should be long enough to extend **BEYOND** the jamb flashing and adhere a minimum of 2" onto the wall.

*DuPont™ Flashing Tape is only permitted for Residential-Use building structures. Residential-Use (Group R) is defined by the 2018/2021 International Building Code.

Installation Methods for DuPont Self-Adhered Flashing Products Installed AFTER the DuPont™ Tyvek® WRB

Drip Cap Installation for Windows and Doors

Option 2 (continued)

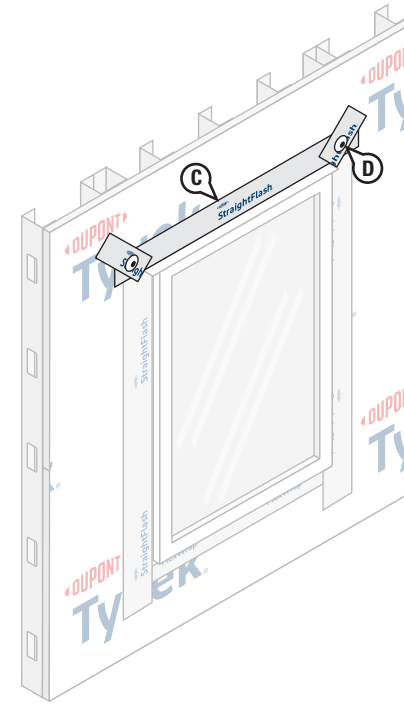
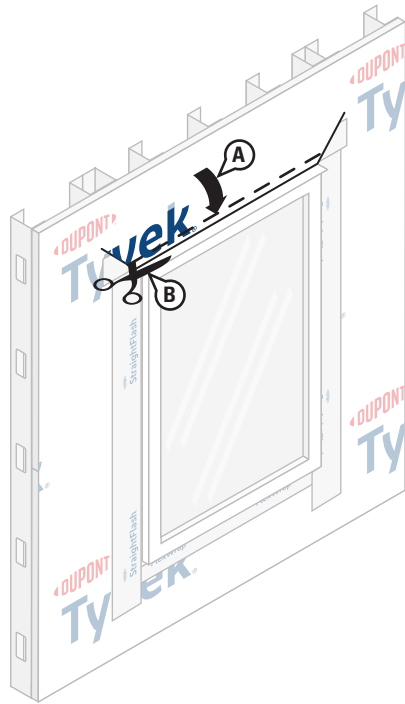

STEP 2

- A. Flip down **DuPont™ Tyvek® WRB** head flap so it lays flat across the **DuPont™ StraightFlash™** or **DuPont™ Flashing Tape*** covering the drip cap and window head flange.
- B. Cut 1"– 2" strip of the **Tyvek® WRB** at lower horizontal edge of head flap.

- C. Starting along the horizontal, terminate the head flap with 4" **DuPont™ StraightFlash™**. (See [Special Considerations](#) for allowances for using 4" **DuPont™ Flashing Tape** or 3" **Tyvek® Tape** in lieu of **StraightFlash™**).
- D. Install **DuPont™ Tyvek® Wrap Cap Fasteners** or recommended fasteners at appropriate spacing at head.

NOTE: For a more robust install, areas with extreme wind load exposures, or high performance testing use 4" **StraightFlash™** to seal the head flap and install additional mechanical fasteners through the flashing at the head flap and perimeter of window.

***DuPont™ Flashing Tape** is only permitted for Residential-Use building structures. Residential-Use (Group R) is defined by the 2018/2021 International Building Code.

Installation Methods for DuPont Self-Adhered Flashing Products Installed **AFTER** the DuPont™ Tyvek® WRB

Drip Cap Installation for Windows and Doors

Option 3
This option may be used for integral flanged, brick mold, field applied flanged, and non-flanged windows and doors. A drip cap can be installed over the **DuPont™ Tyvek® WRB** above the window head **AFTER** the **Tyvek® WRB** head flap is flipped down and sealed.

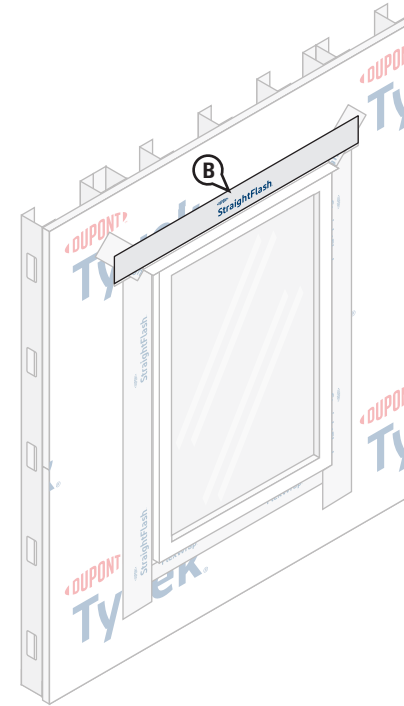
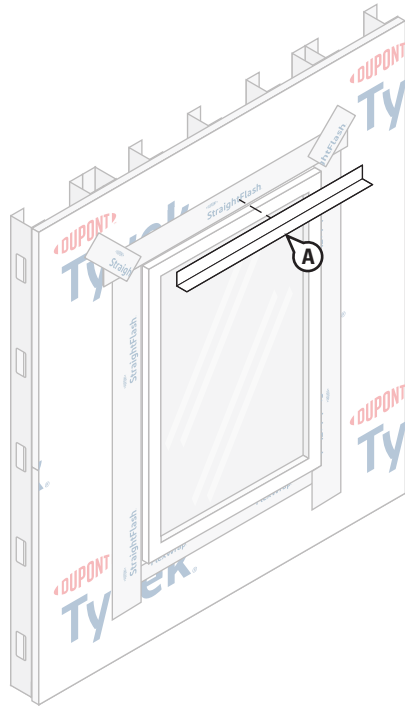

STEP 1

- A. After **Tyvek® WRB** head flap is flipped down, trimmed 1"– 2", and terminated with 4" **DuPont™ StraightFlash™**, or 4" **DuPont™ Flashing Tape***, cut metal or vinyl drip cap slightly **LONGER** than the width of the window and install.
- B. As a recommended best practice, cover the top edge of the drip cap with **StraightFlash™** or **DuPont™ Flashing Tape*** extending past the top and sides of the drip cap and side edges of the window head flashing.

***DuPont™ Flashing Tape** is only permitted for Residential-Use building structures. Residential-Use (Group R) is defined by the 2018/2021 International Building Code.

Installation Methods for DuPont Self-Adhered Flashing Products Installed AFTER the DuPont™ Tyvek® WRB

Brick Mold Window^{1,2}

This installation guide can also be used for windows with field applied nailing fins.

This method applies to the following products: DuPont™ VersaFlange™ and DuPont™ FlexWrap™

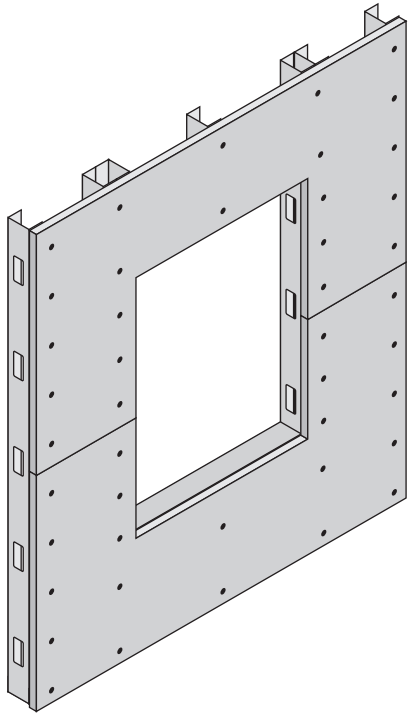

STEP 1

- B. Cut rough opening in sheathing for window. Ensure that sheathing is cut flush with, or slightly below the sill framing to allow for positive drainage.

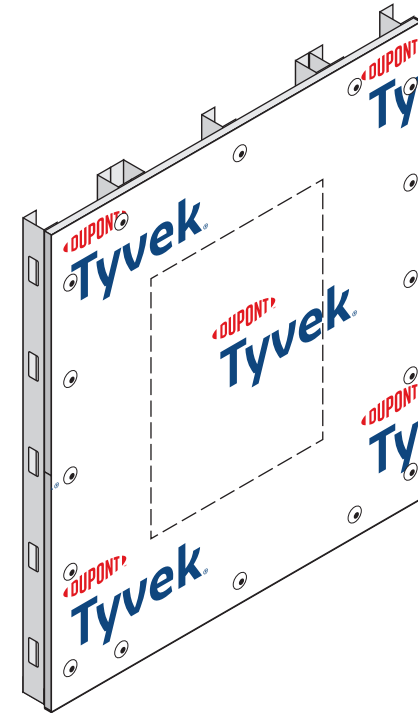

STEP 2

- A. Wrap wall as shown in the [DuPont™ Tyvek® WRB Installation Instructions](#) section in this guide. Do not install fasteners within 6" of the sills and jambs of the openings and within 9" of the head of the openings.

Installation Methods for DuPont Self-Adhered Flashing Products Installed AFTER the DuPont™ Tyvek® WRB Brick Mold Window^{1,2}

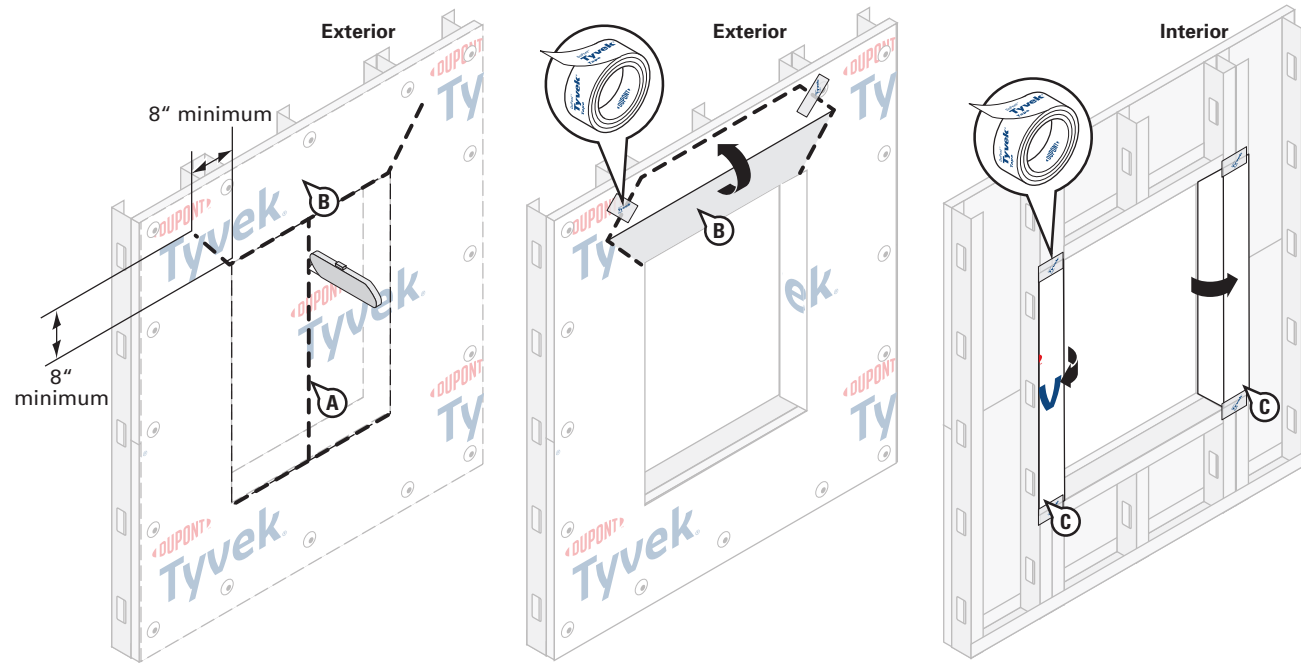

STEP 3

Prepare Tyvek® WRB for Window Installation

- Make an “I-Cut” in the Tyvek® WRB. For an “I-Cut” begin with a horizontal cut across the bottom and the top of the window frame (for round top windows, cut from the center cut straight down to the sill).
- Cut two 45° slits a minimum of 8” from the corner of the header to create a flap above the rough opening to expose sheathing or framing members and to allow head flashing installation (see step 5). Flip head flap up and temporarily secure with DuPont™ Tyvek® Tape. Some windows and flashing widths may require longer slits due to window shape.

- Fold side flaps into rough opening, cut excess flaps, and secure.

NOTE: Side flaps should cover interior facing framing stud.

¹ For Residential-Use building structures. Residential-Use (Group R) is defined by the 2018/2021 International Building Code.

² For smooth-framed window installations not exceeding ASTM E1677 wind loading pressures (10.8 psf, 65 mph equivalent structural load) and ASTM E331 water infiltration resistance of 6.24 psf.

Installation Methods for DuPont Self-Adhered Flashing Products Installed **AFTER** the DuPont™ Tyvek® WRB

Brick Mold Window^{1,2}

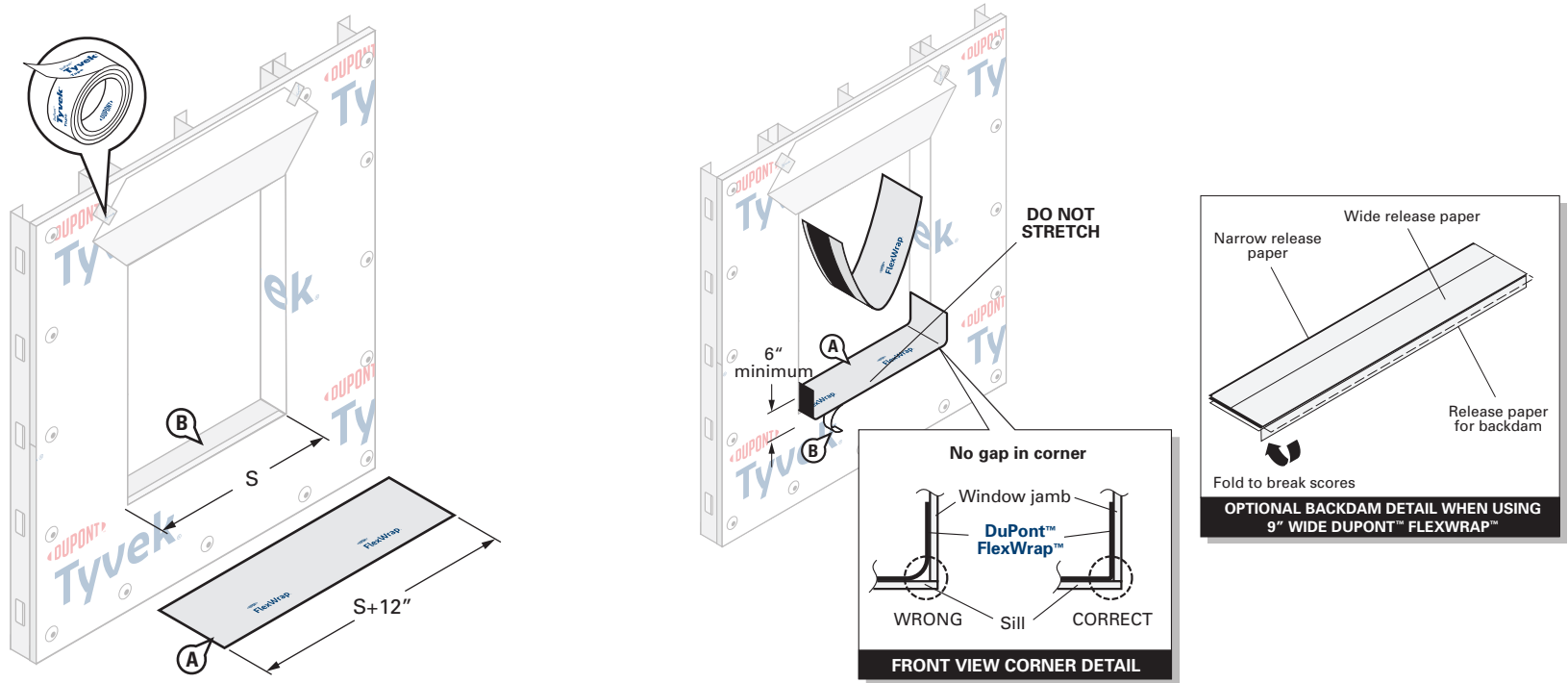

STEP 4

- A. Cut **DuPont™ FlexWrap™** at least 12" **LONGER** than the width of rough opening sill (S). Use roll widths sufficient to achieve a minimum of 1" adhesion **BEYOND** where the back of the window frame will be located, ensuring 2"– 3" adhesion onto the face of the wall.
- B. Inspect installation surface to ensure surface is free of dirt or substances that could interfere with adhesion as well as any sharp protrusions.

STEP 5

- A. Remove wide piece of release paper. Position on horizontal sill by aligning the inside edge of the narrow release paper with the face of the wall to ensure 2"– 3" of the **FlexWrap™** will be adhered to the face of the wall with a minimum of 6" up each jamb. Adhere into rough opening.
- Optional Back Dam:** Fold 9" **FlexWrap™** to break perforation. Remove center piece of release paper. Cover horizontal sill to accommodate back dam as appropriate, and adhere into rough opening along sill and up jambs (min 6" on each side). Leave 1" release paper on **FlexWrap™** inside rough opening to finish back dam after window installation.
- B. Remove narrow release paper.

NOTE: DuPont™ Tyvek® Commercial Certified Installers may install a 3-piece head (and sill) detail for window openings less than 6 ft. wide. Installers who **are not** DuPont™ Tyvek® Commercial Certified Installers should refer to the [Special Considerations](#) section for more information regarding the 3-piece head/sill detail. Contact your local DuPont Building Envelope Specialist for more information about the Certified Installer program.

¹ For Residential-Use building structures. Residential-Use (Group R) is defined by the 2018/2021 International Building Code.

² For smooth-framed window installations not exceeding ASTM E1677 wind loading pressures (10.8 psf, 65 mph equivalent structural load) and ASTM E331 water infiltration resistance of 6.24 psf.

Installation Methods for DuPont Self-Adhered Flashing Products Installed **AFTER** the DuPont™ Tyvek® WRB Brick Mold Window^{1,2}

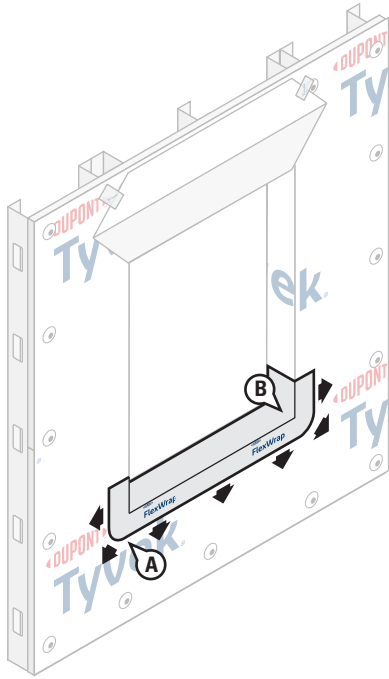

STEP 6

- A. Fan out the **DuPont™ FlexWrap™** at corners and adhere onto face of wall. Continue adhering onto face of wall along sill.
- B. Firmly press sill flashing to ensure full adhesion on all surfaces. Eliminate wrinkles and bubbles by smoothing surface and repositioning as necessary.

¹ For Residential-Use building structures. Residential-Use (Group R) is defined by the 2018/2021 International Building Code.

² For smooth-framed window installations not exceeding ASTM E1677 wind loading pressures (10.8 psf, 65 mph equivalent structural load) and ASTM E331 water infiltration resistance of 6.24 psf.

Installation Methods for DuPont Self-Adhered Flashing Products Installed AFTER the DuPont™ Tyvek® WRB

Brick Mold Window^{1,2}

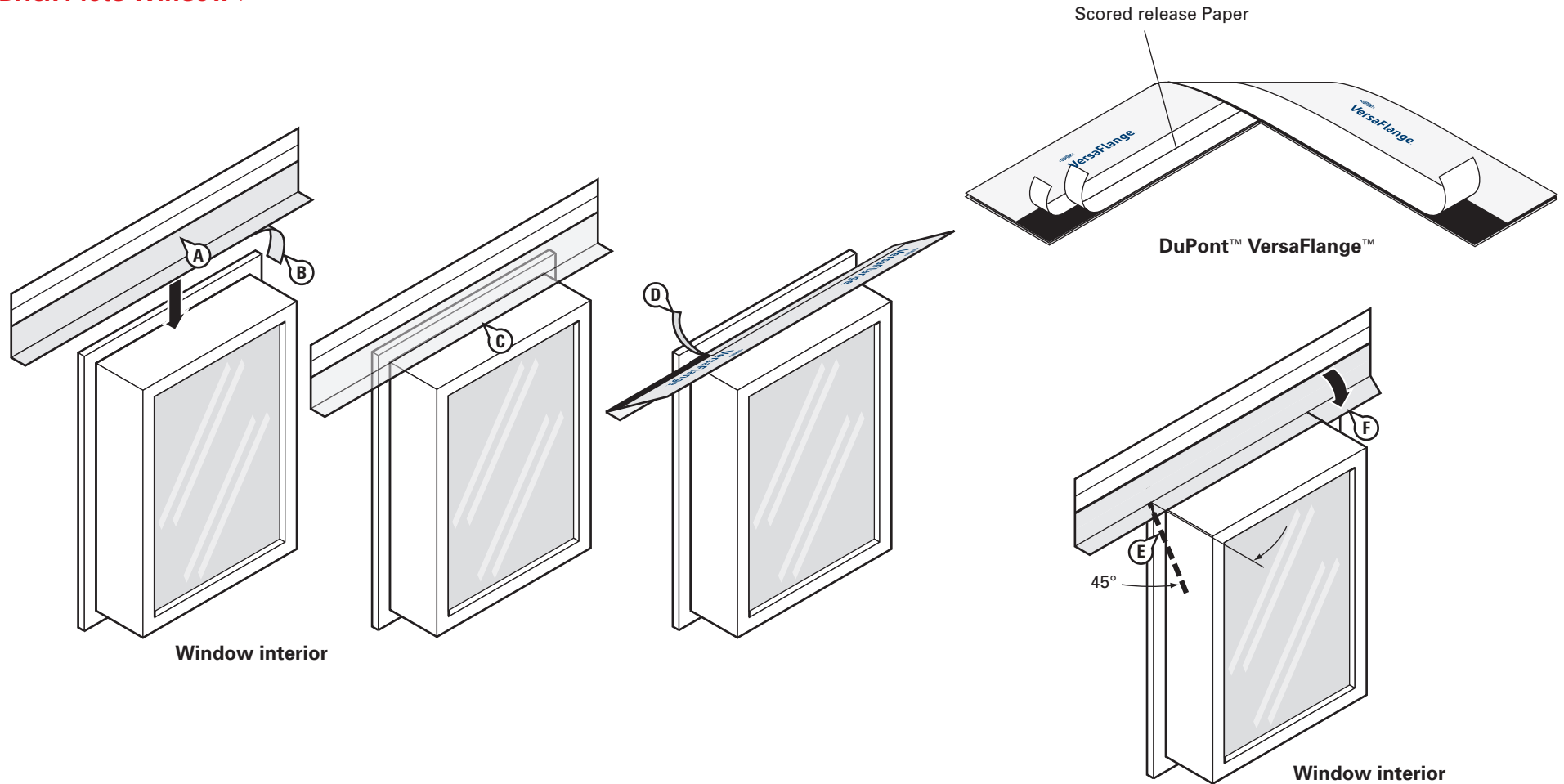

STEP 7

- Prepare head flashing by cutting a piece of **DuPont™ VersaFlange™** at least 12" **LONGER** than the head length.
- Break the scored release paper on one side of the head flashing by folding it back and forth upon itself.
- Center the **VersaFlange™** on the window head and position so that it contacts the window frame and interior side of the brick mold. Remove the outer release paper and adhere the flashing to the window frame. Use the inner release paper to form a tight seal in the corner where the brick mold attaches to the window frame.
- Remove the inner release paper and adhere the flashing to the back of the brick mold and the window casing.
- At the corner of the window frame, cut the **VersaFlange™** along the corner at a 45° angle.
- Fold the **VersaFlange™** down flat against the brick mold.

¹ For Residential-Use building structures. Residential-Use (Group R) is defined by the 2018/2021 International Building Code.

² For smooth-framed window installations not exceeding ASTM E1677 wind loading pressures (10.8 psf, 65 mph equivalent structural load) and ASTM E331 water infiltration resistance of 6.24 psf.

Installation Methods for DuPont Self-Adhered Flashing Products Installed AFTER the DuPont™ Tyvek® WRB

Brick Mold Window^{1,2}

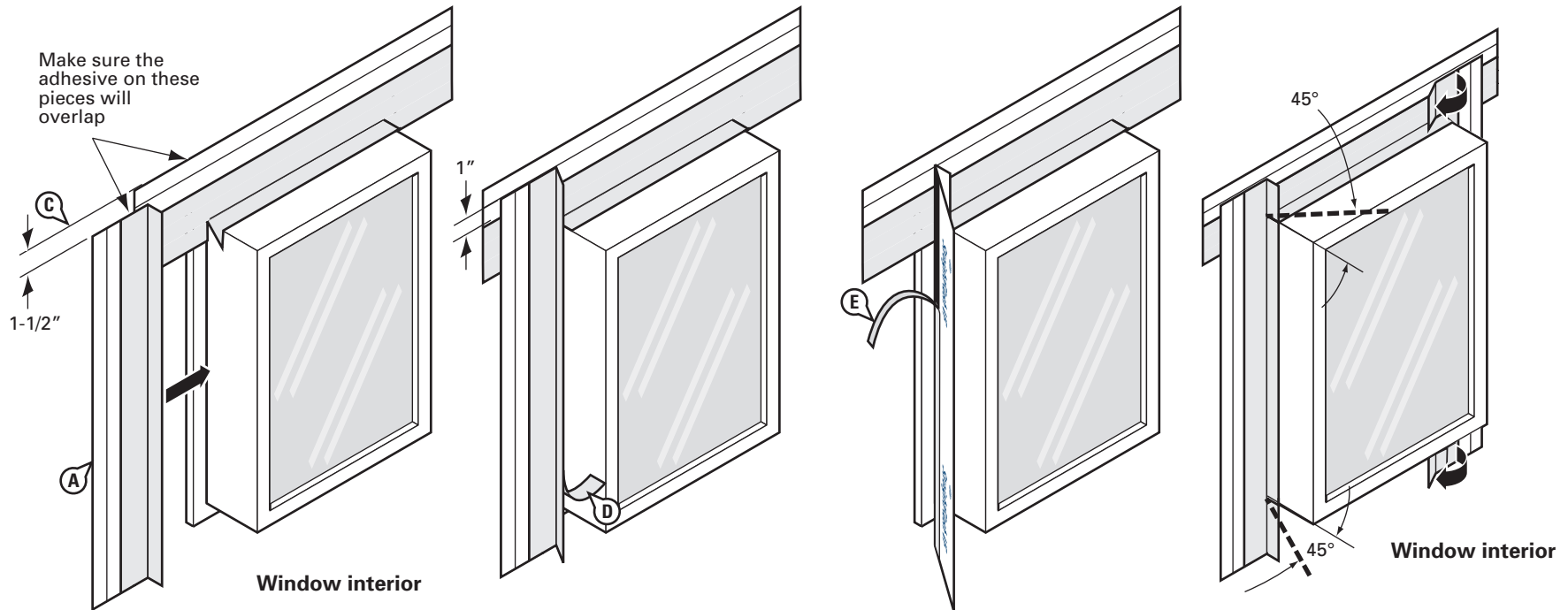

STEP 8

- Prepare jamb flashing by cutting a piece of **DuPont™ VersaFlange™** at least 6" **LONGER** than the jamb.
- Break the scored release paper on one side of the jamb flashing by folding it back and forth upon itself.
- Position so that it contacts the window frame and interior side of the brick mold. Ensure that the jamb flashing is positioned 1-1/2" below the top edge of the head flashing. **Jamb flashing adhesive must come in contact with head flashing adhesive and overlap by 1"**.
- Remove the outer release paper and adhere the flashing to the window frame. Use the inner release paper to form a tight seal in the corner.
- Remove the inner release paper and adhere the flashing to the back of the brick mold.
- At the corner of the window frame, cut the **VersaFlange™** along the corner and fold it down flat to adhere against the head flashing.

¹ For Residential-Use building structures. Residential-Use (Group R) is defined by the 2018/2021 International Building Code.

² For smooth-framed window installations not exceeding ASTM E1677 wind loading pressures (10.8 psf, 65 mph equivalent structural load) and ASTM E331 water infiltration resistance of 6.24 psf.

Installation Methods for DuPont Self-Adhered Flashing Products Installed **AFTER** the DuPont™ Tyvek® WRB Brick Mold Window^{1,2}

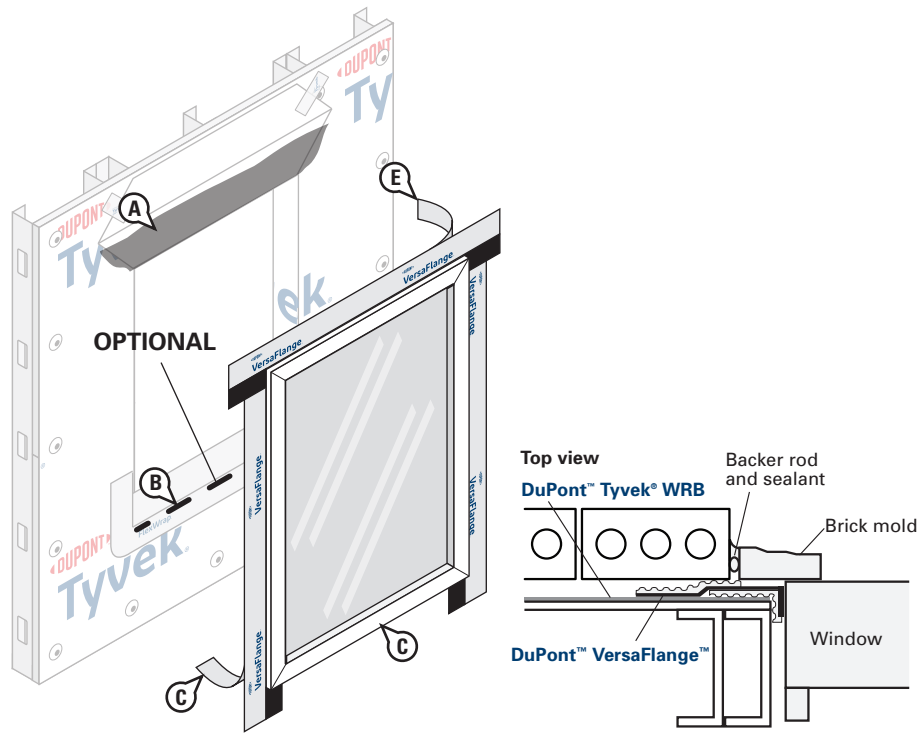

STEP 9

- Apply a recommended adhesive/primer to exposed sheathing.
- OPTIONAL:** Apply a recommended sealant along the sill as shown above. **To allow for drainage, do not apply continuous sealant bead along sill.** Ensure a minimum 2" wide drainage gap in the sealant bead within 4" from **each corner** of the jamb-sill interface. Continue applying sealant along the sill with additional 2" wide (min.) drainage gaps for every 6"- 12" (on center) of sill width.
- Install window according to manufacturer's installation instructions.
- Remove the remaining release paper from the **DuPont™ VersaFlange™** jamb flashing and press firmly to adhere it to the **Tyvek® WRB**.
- Remove the release paper at the head and adhere it to the wall surface.

OPTIONAL: Cover exposed butyl with **DuPont™ StraightFlash™**, **DuPont™ Flashing Tape**, or **DuPont™ Tyvek® Tape**.

¹ For Residential-Use building structures. Residential-Use (Group R) is defined by the 2018/2021 International Building Code.

² For smooth-framed window installations not exceeding ASTM E1677 wind loading pressures (10.8 psf, 65 mph equivalent structural load) and ASTM E331 water infiltration resistance of 6.24 psf.

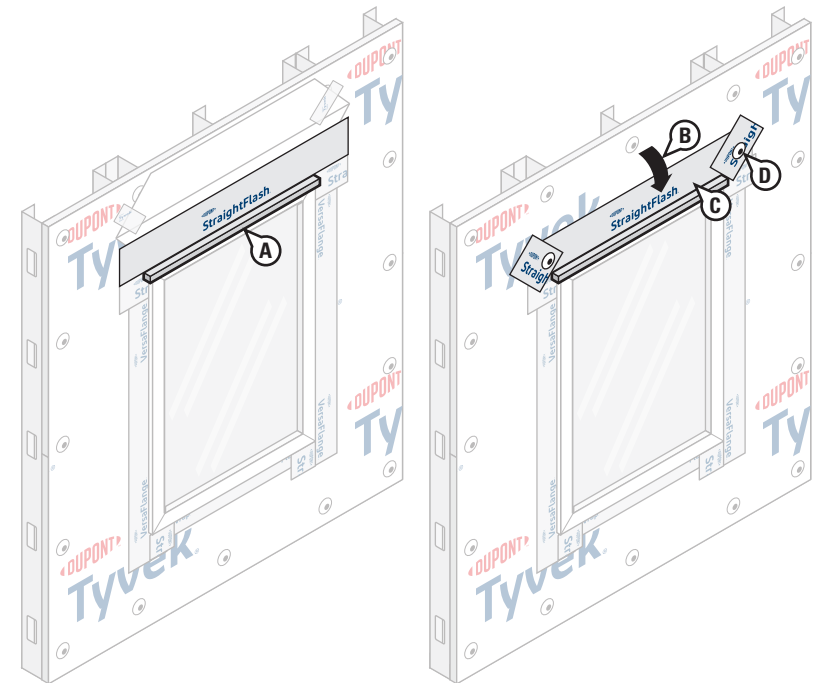

STEP 10

- Cut a piece of metal or vinyl drip cap slightly **LONGER** than the window's width and place a bead of sealant on the rear side. Install the drip cap tight against the window head and cover the top edge with 4" **StraightFlash™**.
- Flip down upper flap of **Tyvek® WRB** so it lays flat across head flashing, then **trim 1"- 2" above the window opening**.
- Starting along the horizontal, terminate the head flap with 4" **DuPont™ StraightFlash™**. (See [Special Considerations](#) for allowances for using 4" **DuPont™ Flashing Tape** or 3" **Tyvek® Tape** in lieu of **StraightFlash™**).
- Install **DuPont™ Tyvek® Wrap Cap Fasteners**, or recommended fasteners according to fastening schedule.

NOTE: For a more robust install, areas with extreme wind load exposures, or high performance testing use 4" **StraightFlash™** to seal the head flap and install additional mechanical fasteners through the flashing at the head flap and perimeter of window.

Installation Methods for DuPont Self-Adhered Flashing Products Installed AFTER the DuPont™ Tyvek® WRB Brick Mold Window^{1,2}

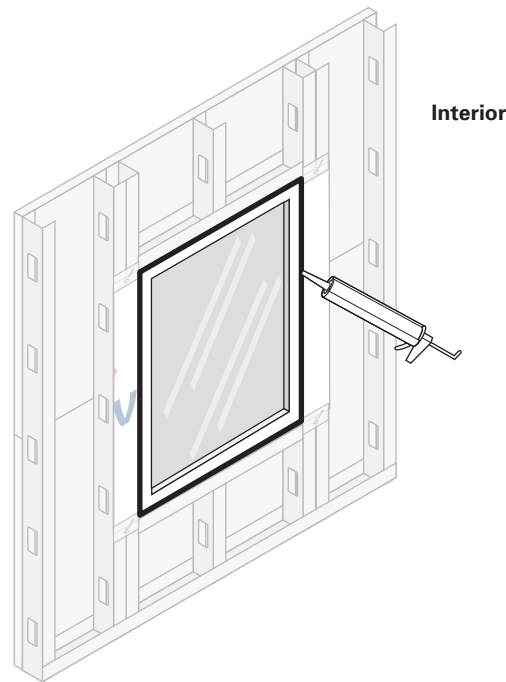

STEP 11

Final Step

Create a continuous perimeter seal using backer rod and recommended sealant or **Great Stuff Pro™ Window and Door Polyurethane Foam Sealant** on window interior to resist air and water infiltration. When using **Great Stuff Pro™ Window and Door Polyurethane Foam Sealant** in perimeter openings less than ½", apply using the plastic extension tip for the **Great Stuff Pro™ Dispenser Gun** during installation.

NOTE: For high performance installations exceeding ASTM E1677 wind loading pressures (10.8 psf, 65 mph equivalent structural load) and ASTM E331 water infiltration resistance of 6.24 psf, it is necessary to install sealant over the cured foam when using **Great Stuff Pro™ Window and Door Polyurethane Foam Sealant** or other recommended foam. Sealant should be installed over the foam between the window frame and rough opening around the entire interior perimeter. If **Great Stuff Pro™ Window and Door Polyurethane Foam Sealant** or other recommended foam extends **BEYOND** the window frame, shave the excess cured foam flush with the window frame before applying sealant. Avoid damaging the **DuPont Self-Adhered Flashing Product** or **DuPont™ Tyvek® WRB**.

NOTE: Refer to [Chemical Compatibility of Representative Building Sealants and Adhesives/Primers](#) for more information on recommended sealant.

¹ For Residential-Use building structures. Residential-Use (Group R) is defined by the 2018/2021 International Building Code.

² For smooth-framed window installations not exceeding ASTM E1677 wind loading pressures (10.8 psf, 65 mph equivalent structural load) and ASTM E331 water infiltration resistance of 6.24 psf.

Installation Methods for DuPont Self-Adhered Flashing Products Installed AFTER the DuPont™ Tyvek® WRB Non-Flanged Window Using DuPont™ VersaFlange™ 1,2

While the depictions and instructions for this method refer to a non-flanged window, this method is also applicable for a non-flanged door^{1,2}

This method applies to the following products: DuPont™ VersaFlange™, DuPont™ FlexWrap™, and DuPont™ FlexWrap™ EZ

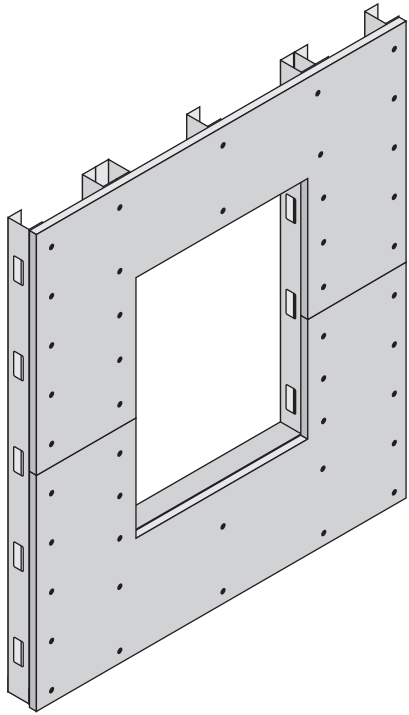

STEP 1

E. Cut rough opening in sheathing for window. Ensure that sheathing is cut flush with, or slightly below the sill framing to allow for positive drainage.

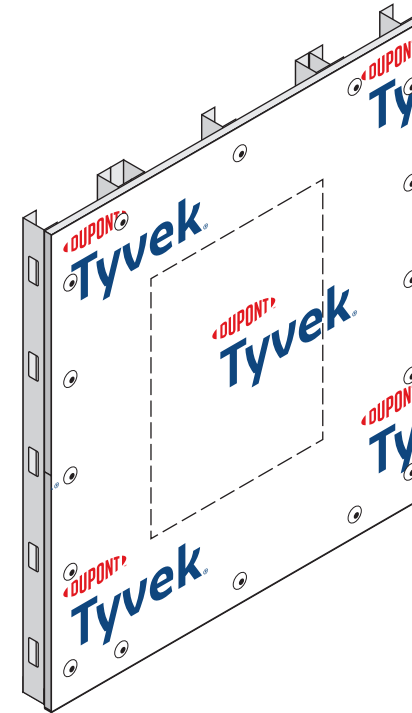

STEP 2

A. Wrap wall as shown in the [DuPont™ Tyvek® WRB Installation Instructions](#) section in this guide. Do not install fasteners within 6" of the sills and jambs of the openings and within 9" of the head of the openings.

Installation Methods for DuPont Self-Adhered Flashing Products Installed AFTER the DuPont™ Tyvek® WRB Non-Flanged Window Using DuPont™ VersaFlange™ 1,2

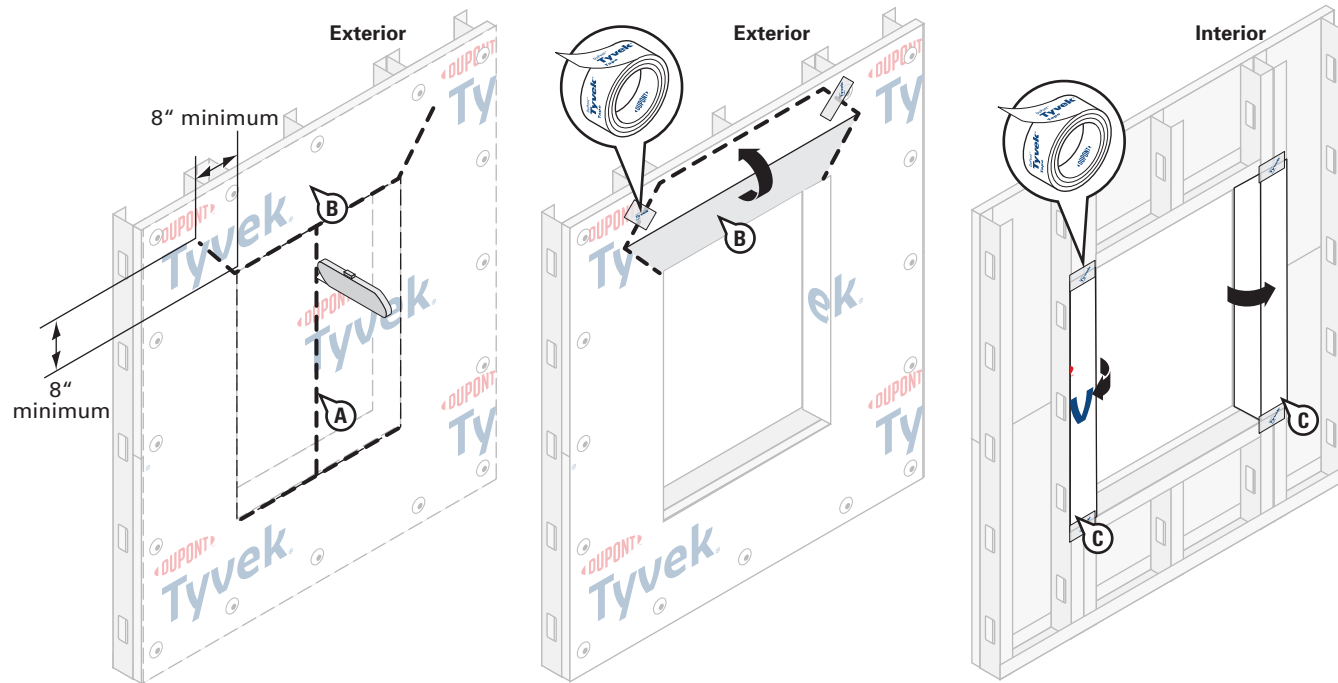

STEP 3

Prepare Tyvek® WRB For Window Installation

- A. Make an "I-Cut" in the Tyvek® WRB. For an "I-Cut" begin with a horizontal cut across the bottom and the top of the window frame. From the center cut straight down to the sill.
- B. Cut two 45° slits a minimum of 8" from the corner of the header to create a flap above the rough opening to expose sheathing or framing members and to allow head flashing installation (see step 5). Flip head flap up and temporarily secure with DuPont™ Tyvek® Tape. Some windows and flashing widths may require longer slits.
- C. Fold side flaps into rough opening, cut excess flaps, and secure. Side flaps should cover interior facing framing stud.

1 For Residential-Use building structures. Residential-Use (Group R) is defined by the 2018/2021 International Building Code.

2 For smooth-framed window installations not exceeding ASTM E1677 wind loading pressures (10.8 psf, 65 mph equivalent structural load) and ASTM E331 water infiltration resistance of 6.24 psf.

Installation Methods for DuPont Self-Adhered Flashing Products Installed **AFTER** the DuPont™ Tyvek® WRB Non-Flanged Window Using DuPont™ VersaFlange™ 1,2

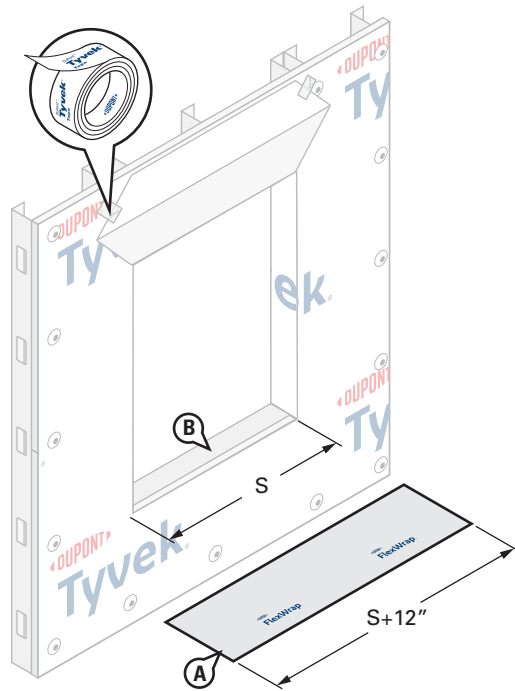

STEP 4

- A. Cut **DuPont™ FlexWrap™** at least 12" **LONGER** than the width of rough opening sill (S). Use roll widths sufficient to achieve a minimum of 1" adhesion **BEYOND** where the back of the window frame will be located, ensuring 2"– 3" adhesion onto the face of the wall.
- B. Inspect installation surface to ensure surface is free of dirt or substances that could interfere with adhesion as well as any sharp protrusions.

NOTE: DuPont™ Tyvek® Commercial Certified Installers may install a 3-piece head (and sill) detail for window openings less than 6 ft. wide. Installers who **are not** DuPont™ Tyvek® Commercial Certified Installers should refer to the [Special Considerations](#) section for more information regarding the 3-piece head/sill detail. Contact your local DuPont Building Envelope Specialist for more information about the Certified Installer program.

¹For Residential-Use building structures. Residential-Use (Group R) is defined by the 2018/2021 International Building Code.

²For smooth-framed window installations not exceeding ASTM E1677 wind loading pressures (10.8 psf, 65 mph equivalent structural load) and ASTM E331 water infiltration resistance of 6.24 psf.

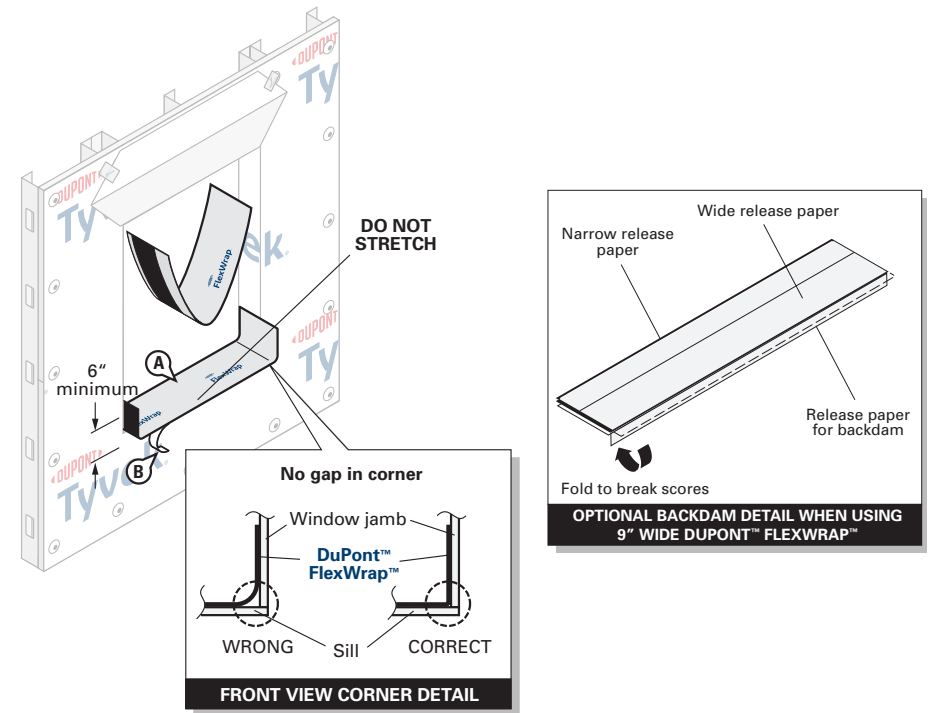

STEP 5

- A. Remove wide piece of release paper. Position on horizontal sill by aligning the inside edge of the narrow release paper with the face of the wall to ensure 2"– 3" of the **FlexWrap™** will be adhered to the face of the wall with a minimum of 6" up each jamb. Adhere into rough opening.
Optional Back Dam: Fold 9" **FlexWrap™** to break perforation. Remove center piece of release paper. Cover horizontal sill to accommodate back dam as appropriate, and adhere into rough opening along sill and up jambs (min 6" on each side). Leave 1" release paper on **FlexWrap™** inside rough opening to finish back dam after window installation.
- B. Remove narrow release paper.

Installation Methods for DuPont Self-Adhered Flashing Products Installed **AFTER** the DuPont™ Tyvek® WRB Non-Flanged Window Using DuPont™ VersaFlange™ 1,2

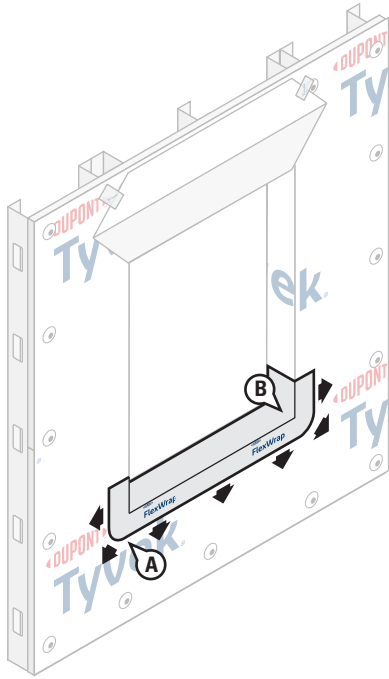

STEP 6

- A. Fan out the **DuPont™ FlexWrap™** at corners and adhere onto face of wall. Continue adhering onto face of wall along sill.
- B. Firmly press sill flashing to ensure full adhesion on all surfaces. Eliminate wrinkles and bubbles by smoothing surface and repositioning as necessary.

¹For Residential-Use building structures. Residential-Use (Group R) is defined by the 2018/2021 International Building Code.

²For smooth-framed window installations not exceeding ASTM E1677 wind loading pressures (10.8 psf, 65 mph equivalent structural load) and ASTM E331 water infiltration resistance of 6.24 psf.

Installation Methods for DuPont Self-Adhered Flashing Products Installed **AFTER** the DuPont™ Tyvek® WRB Non-Flanged Window Using DuPont™ VersaFlange™ 1,2

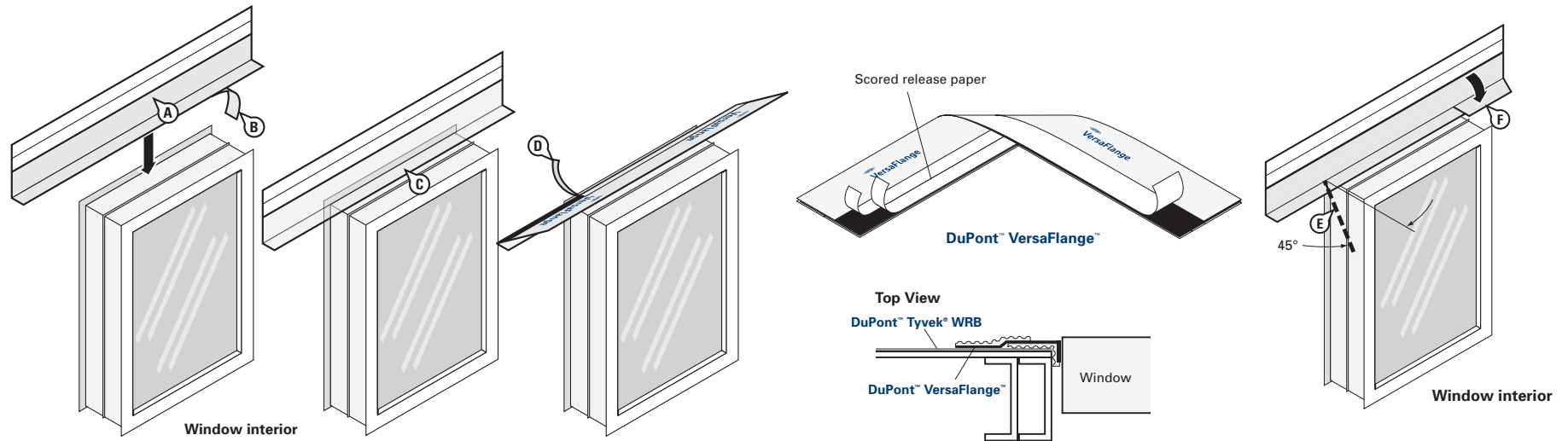

STEP 7

- A. Prepare head flashing by cutting a piece of **DuPont™ VersaFlange™** at least 12" **LONGER** than the head length. Before flashing, prime window fins and casings with a recommended adhesive/primer.
- B. Break the scored release paper on one side of the head flashing by folding it back and forth upon itself.
- C. Center the flashing on the window head and position so that it contacts the window frame and interior side of the front flange. Remove the outer release paper and adhere the flashing to the window frame. Use the inner release paper to form a tight seal in the corner.
- D. Remove the inner release paper and adhere the flashing to the back of the aluminum window fin and casing.
- E. At the corner of the window frame, cut the **VersaFlange™** along the corner at a 45° angle.
- F. Fold the **VersaFlange™** down flat.

¹For Residential-Use building structures. Residential-Use (Group R) is defined by the 2018/2021 International Building Code.

²For smooth-framed window installations not exceeding ASTM E1677 wind loading pressures (10.8 psf, 65 mph equivalent structural load) and ASTM E331 water infiltration resistance of 6.24 psf.

Installation Methods for DuPont Self-Adhered Flashing Products Installed AFTER the DuPont™ Tyvek® WRB Non-Flanged Window Using DuPont™ VersaFlange™ 1,2

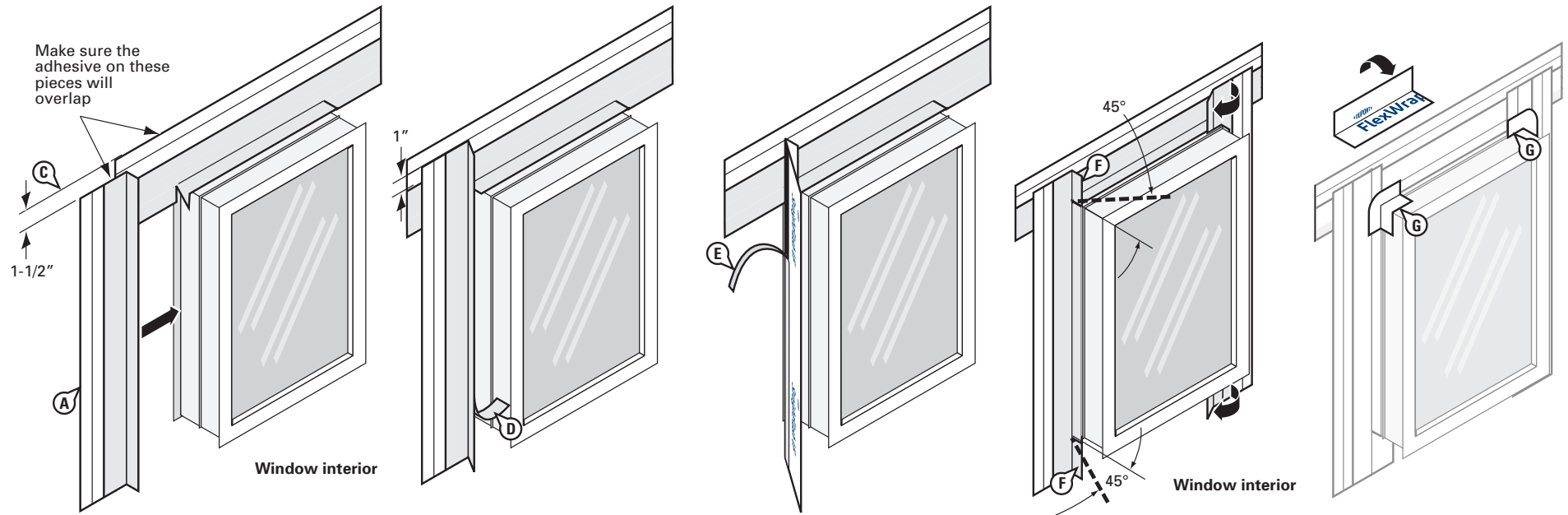

STEP 8

- A. Prepare jamb flashing by cutting a piece of **DuPont™ VersaFlange™** at least 6" **LONGER** than the jamb.
- B. Break the scored release paper on one side of the jamb flashing by folding it back and forth upon itself.
- C. Position the flashing so that it contacts the window frame and interior side of the aluminum window fin. Ensure that the jamb flashing is positioned 1-1/2 inch below the top edge of the head flashing. **Jamb flashing adhesive must come in contact with head flashing adhesive and overlap by 1"**.
- D. Remove the outer release paper and adhere the flashing to the window frame. Use the inner release paper to form a tight seal in the corner.
- E. Remove the inner release paper and adhere the flashing to the back of the aluminum window fin.
- F. At the corner of the window frame, cut the **VersaFlange™** along the corner and fold it down flat to adhere against the head flashing.
- G. Cut a 2" x 4" piece of **DuPont™ FlexWrap™** or a 4" piece of **DuPont™ FlexWrap™ EZ** and patch each corner.

¹For Residential-Use building structures. Residential-Use (Group R) is defined by the 2018/2021 International Building Code.

²For smooth-framed window installations not exceeding ASTM E1677 wind loading pressures (10.8 psf, 65 mph equivalent structural load) and ASTM E331 water infiltration resistance of 6.24 psf.

Installation Methods for DuPont Self-Adhered Flashing Products Installed AFTER the DuPont™ Tyvek® WRB

Non-Flanged Window Using DuPont™ VersaFlange™ 1,2

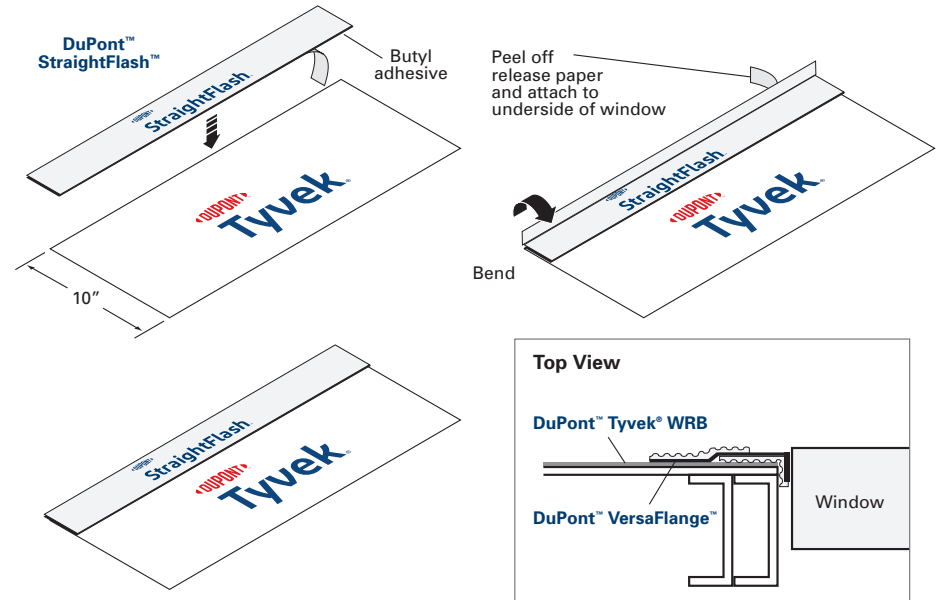
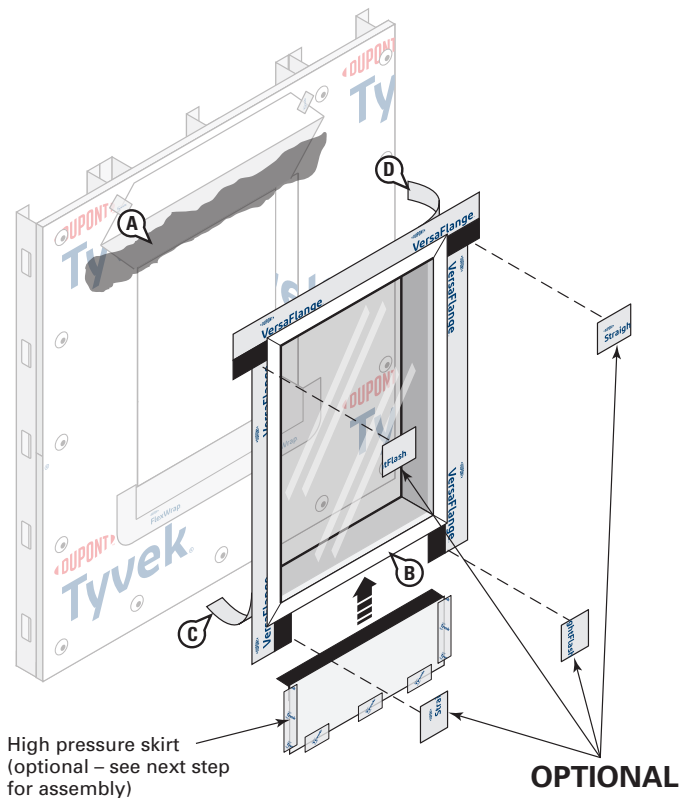

STEP 9

- Apply a recommended adhesive/primer to exposed sheathing. Refer to [Chemical Compatibility of Representative Building Sealants and Adhesives/Primers](#) for more information on recommended adhesives/primers.
- Install window according to manufacturer's installation instructions. If sealant is applied to the sill, ensure that there are at least two (2) 2" gaps in the sealant bead for every 4' of window to allow for drainage.
- Remove the remaining release paper from the **DuPont™ VersaFlange™** jamb flashing and press firmly to adhere it to the **Tyvek® WRB**.
- Remove the release paper at the head and adhere it to the wall surface.

OPTIONAL: Cover exposed butyl with **DuPont™ StraightFlash™**, **DuPont™ Flashing Tape**, or **DuPont™ Tyvek® Tape**.

STEP 9 – OPTIONAL HIGH-PRESSURE SKIRT

- Create the high-pressure skirt by cutting a piece of **Tyvek® WRB** 1" wider than the width of window opening and approximately 10" in depth.
- Attach skirt to underside of window using a piece of **VersaFlange™** or 4" **StraightFlash™** cut to the same width as the skirt.

¹For Residential-Use building structures. Residential-Use (Group R) is defined by the 2018/2021 International Building Code.

²For smooth-framed window installations not exceeding ASTM E1677 wind loading pressures (10.8 psf, 65 mph equivalent structural load) and ASTM E331 water infiltration resistance of 6.24 psf.

Installation Methods for DuPont Self-Adhered Flashing Products Installed **AFTER** the DuPont™ Tyvek® WRB Non-Flanged Window Using DuPont™ VersaFlange™ 1,2

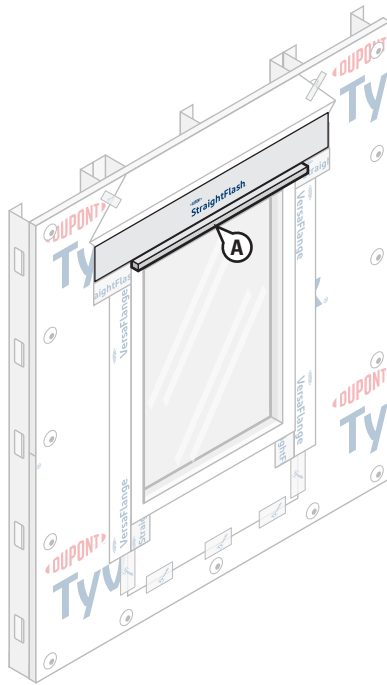

STEP 10

- A. Cut a piece of metal or vinyl drip cap slightly **LONGER** than the window's width and place a bead of recommended sealant on the rear side. Install the drip cap tight against the window head and cover the top edge with **DuPont™ StraightFlash™** or **DuPont™ Tyvek® Tape**.

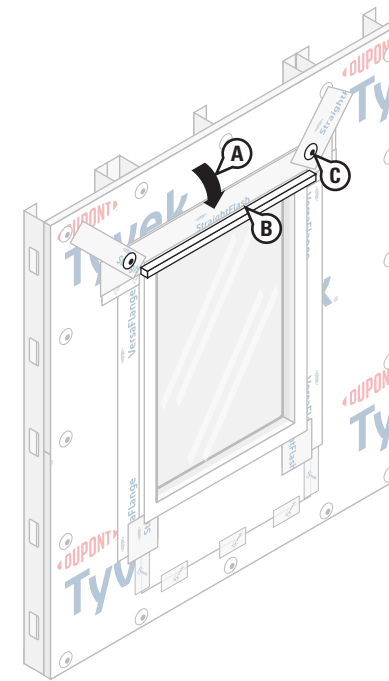

STEP 11

- A. Flip down upper flap of **Tyvek® WRB** so it lays flat across head flashing, then **trim 1"– 2" above the window opening**.
- B. Starting along the horizontal, terminate the head flap with 4" **DuPont™ StraightFlash™**. (See [Special Considerations](#) for allowances for using 4" **DuPont™ Flashing Tape** or 3" **Tyvek® Tape** in lieu of **StraightFlash™**).
- C. Install **DuPont™ Tyvek® Wrap Cap Fasteners** or recommended fasteners at jambs and head flap according to fastening schedule.

NOTE: For a more robust install, areas with extreme wind load exposures, or high performance testing use 4" **StraightFlash™** to seal the head flap and install additional mechanical fasteners through the flashing at the head flap and perimeter of window.

¹For Residential-Use building structures. Residential-Use (Group R) is defined by the 2018/2021 International Building Code.

²For smooth-framed window installations not exceeding ASTM E1677 wind loading pressures (10.8 psf, 65 mph equivalent structural load) and ASTM E331 water infiltration resistance of 6.24 psf.

Installation Methods for DuPont Self-Adhered Flashing Products Installed AFTER the DuPont™ Tyvek® WRB Non-Flanged Window Using DuPont™ VersaFlange™ 1,2

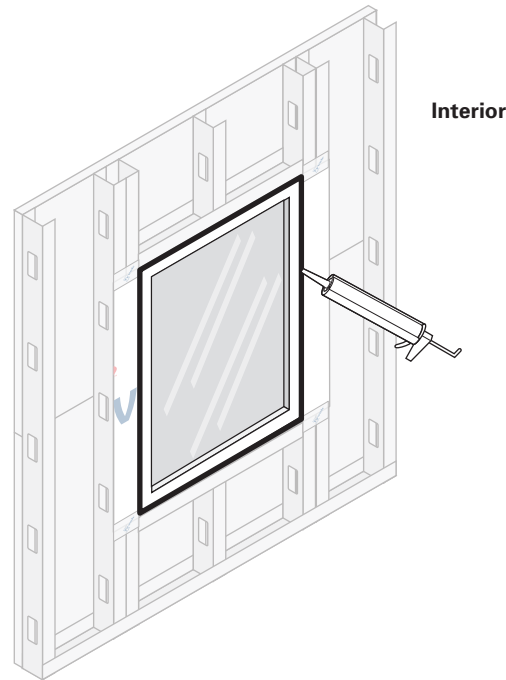

STEP 12

Final Step

Create a continuous perimeter seal using backer rod and recommended sealant or **Great Stuff Pro™ Window and Door Polyurethane Foam Sealant** on window interior to resist air and water infiltration. When using **Great Stuff Pro™ Window and Door Polyurethane Foam Sealant** in perimeter openings less than 1/2", apply using the plastic extension tip for the **Great Stuff Pro™ Dispenser Gun** during installation.

NOTE: For high performance installations exceeding ASTM E1677 wind loading pressures (10.8 psf, 65 mph equivalent structural load) and ASTM E331 water infiltration resistance of 6.24 psf, it is necessary to install sealant over the cured foam when using **Great Stuff Pro™ Window and Door Polyurethane Foam Sealant** or other recommended foam. Sealant should be installed over the foam between the window frame and rough opening around the entire interior perimeter. If **Great Stuff Pro™ Window and Door Polyurethane Foam Sealant** or other recommended foam extends **BEYOND** the window frame, shave the excess cured foam flush with the window frame before applying sealant. Avoid damaging the **DuPont Self-Adhered Flashing Product** or **DuPont™ Tyvek® WRB**.

NOTE: Refer to [Chemical Compatibility of Representative Building Sealants and Adhesives/Primers](#) for more information on recommended sealant.

¹For Residential-Use building structures. Residential-Use (Group R) is defined by the 2018/2021 International Building Code.

²For smooth-framed window installations not exceeding ASTM E1677 wind loading pressures (10.8 psf, 65 mph equivalent structural load) and ASTM E331 water infiltration resistance of 6.24 psf.

Installation Methods for DuPont Self-Adhered Flashing Products Installed **AFTER** the DuPont™ Tyvek® WRB Packaged Terminal Air Conditioner (PTAC) Unit (Using “Wrap the Cavity” Method)

This method is for flashing/protecting the rough opening of a Packaged Terminal Air Conditioner (PTAC) Unit.

This method applies to the following products: DuPont™ StraightFlash™ and DuPont™ FlexWrap™

Option 1 – PTAC Rough Opening Minimum 8” below Window Rough Opening

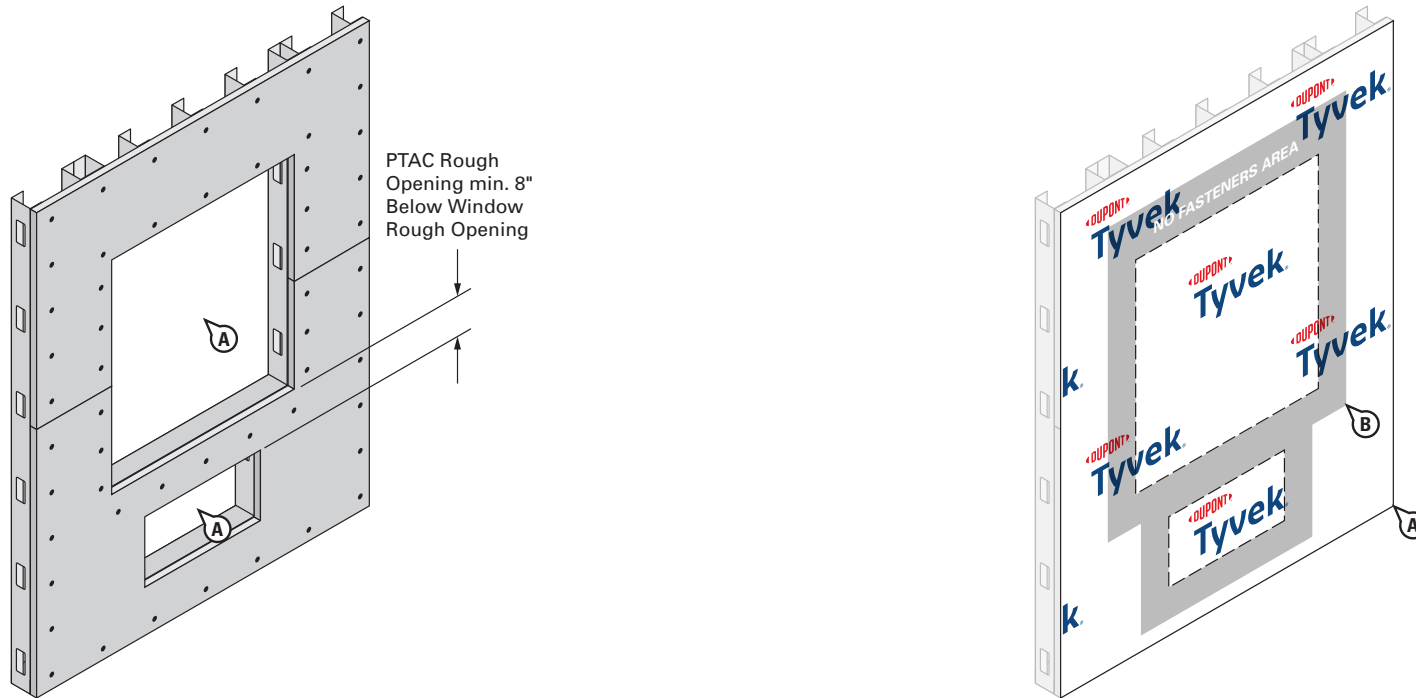

STEP 1

- A. Cut rough opening in sheathing for window and PTAC unit. Ensure that sheathing is cut flush with, or slightly below the sill framing to allow for positive drainage.

STEP 2

- A. Wrap wall as shown in the [DuPont™ Tyvek® WRB Installation Instructions](#) section in this guide.
- B. Do not install fasteners within 6” of the sills and jambs of the openings and within 9” of the head of the openings.

Installation Methods for DuPont Self-Adhered Flashing Products Installed **AFTER** the DuPont™ Tyvek® WRB Packaged Terminal Air Conditioner (PTAC) Unit (Using “Wrap the Cavity” Method)

Option 1 – PTAC Rough Opening Minimum 8” below Window Rough Opening

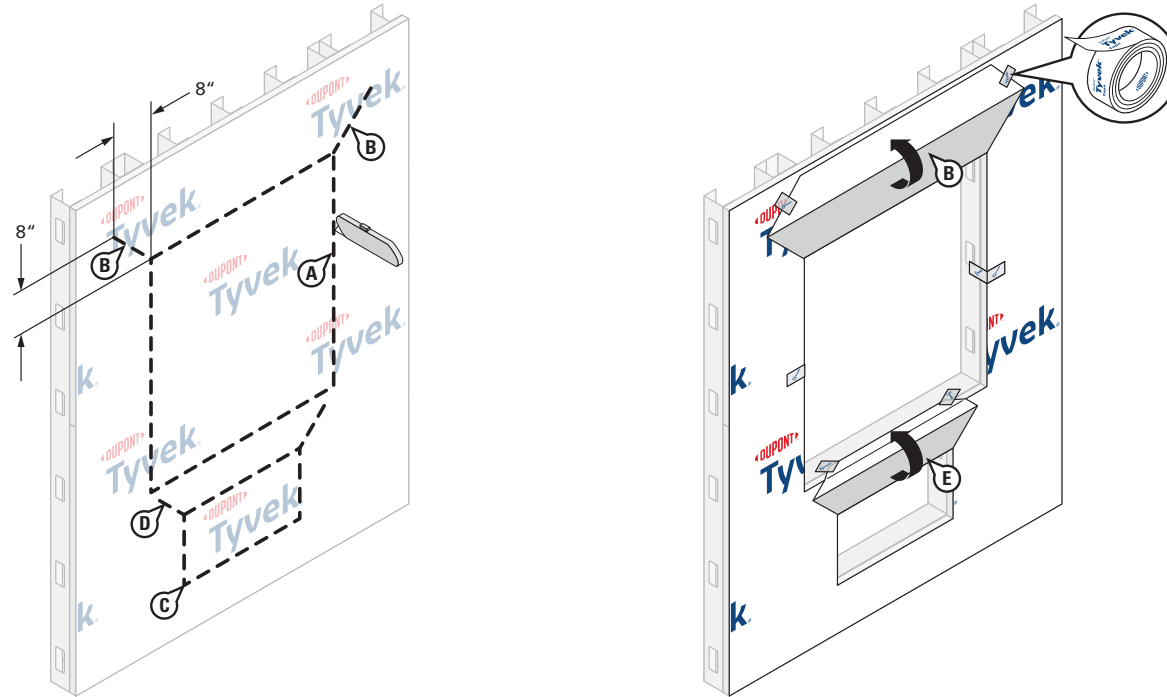

STEP 3

Prepare the Tyvek® WRB for Window and PTAC Installation

A. Using a flush cut (“O-Cut”), cut an opening in the Tyvek® WRB around the perimeter of the rough opening per the [Non-Flanged Window](#) details in this guide. Cuts should be made along the dashed indicated lines. (Ensure the Tyvek® WRB is cut flush with the sheathing and is not wrapped into the rough opening.)

NOTE: If an integral flanged window is installed above the PTAC Unit, follow the applicable detail in this guide.

B. Cut a head flap at a 45° angle to expose 8” of sheathing to allow for head flashing installation. Flip head flap up and temporarily secure with DuPont™ Tyvek® Tape.

ALTERNATE METHOD TO SECURE HEAD FLAPS: In lieu of temporarily taping, the head flap can be tucked under the Tyvek® WRB.

C. Cut an opening in the Tyvek® WRB using a flush cut (“O-Cut”) along the perimeter of the rough opening for the PTAC Unit. Cuts should be made along the dashed indicated lines. (Ensure that the Tyvek® WRB is cut flush with the sheathing and is not wrapped into the rough opening.)

D. Cut two 45 degree slits up and away from the PTAC rough opening, extending from the corner of the head to expose 8” of sheathing to allow for flashing the head of the PTAC Unit.

E. Flip head flap up and temporarily secure with Tyvek® Tape.

Installation Methods for DuPont Self-Adhered Flashing Products Installed AFTER the DuPont™ Tyvek® WRB Packaged Terminal Air Conditioner (PTAC) Unit (Using “Wrap the Cavity” Method)

Option 1 – PTAC Rough Opening Minimum 8” below Window Rough Opening

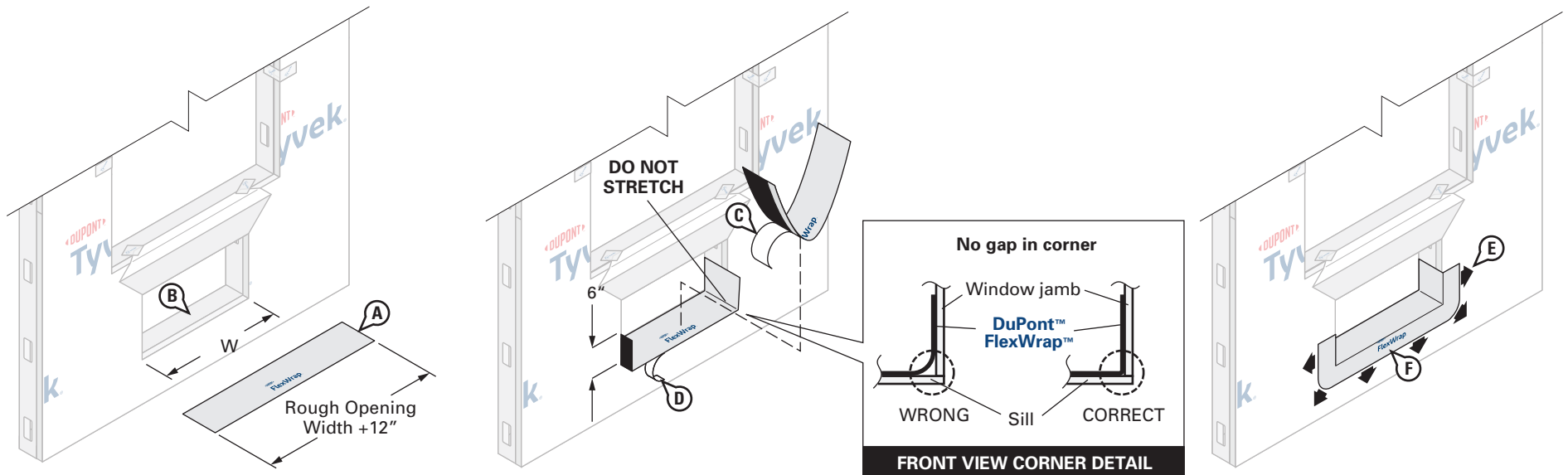

STEP 4

- Cut **DuPont™ FlexWrap™** at least 12” **LONGER** than width of rough opening (W). Use 6” **FlexWrap™** for 2” x 4” framing and 9” **FlexWrap™** for 2” x 6” framing.
- Inspect installation surface to ensure surface is free of dirt or substances that could interfere with adhesion as well as any sharp protrusions.
- Remove wide piece of release paper. Position on horizontal sill by aligning the inside edge of the narrow release paper with the face of the wall to ensure 2”– 3” of the **FlexWrap™** will be adhered to the face of the wall with a minimum of 6” up each jamb. Adhere into rough opening.
- Remove narrow release paper.
- Fan out the **FlexWrap™** at corners and adhere onto face of wall. Continue adhering onto face of wall along sill.
- Firmly press sill flashing to ensure full adhesion on all surfaces. Eliminate wrinkles and bubbles by smoothing surface and repositioning as necessary.

Installation Methods for DuPont Self-Adhered Flashing Products Installed AFTER the DuPont™ Tyvek® WRB Packaged Terminal Air Conditioner (PTAC) Unit (Using “Wrap the Cavity” Method)

Option 1 – PTAC Rough Opening Minimum 8” below Window Rough Opening

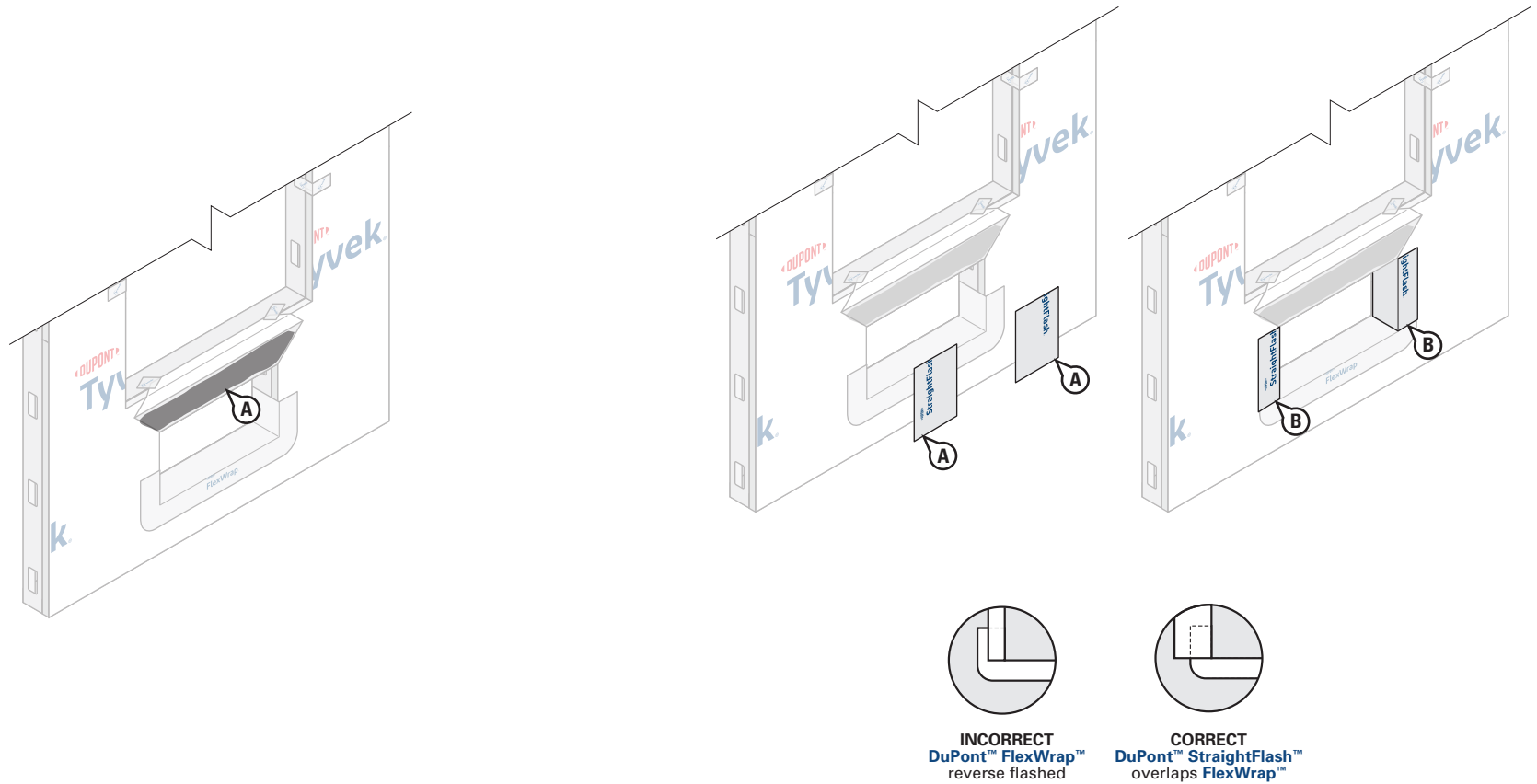

STEP 5

- A. Apply a recommended adhesive/primer to the exposed sheathing along the head of the rough opening for the PTAC Unit. Refer to [Chemical Compatibility of Representative Building Sealants and Adhesives/Primers](#) for more information on recommended adhesives/primers.

STEP 6

- A. Cut two pieces of 9" DuPont™ StraightFlash™ the height of the rough opening for the PTAC Unit. PTAC Unit Jamb flashing should be long enough to overlap the sill flashing by at least 2" and be overlapped by future head flashing by at least 2".
- B. Wrap the StraightFlash™ into the rough opening at each jamb and onto wall face. As a general reference, the flashing should align with the interior edge of the jamb framing.

Installation Methods for DuPont Self-Adhered Flashing Products Installed **AFTER** the DuPont™ Tyvek® WRB Packaged Terminal Air Conditioner (PTAC) Unit (Using “Wrap the Cavity” Method)

Option 1 – PTAC Rough Opening Minimum 8” below Window Rough Opening

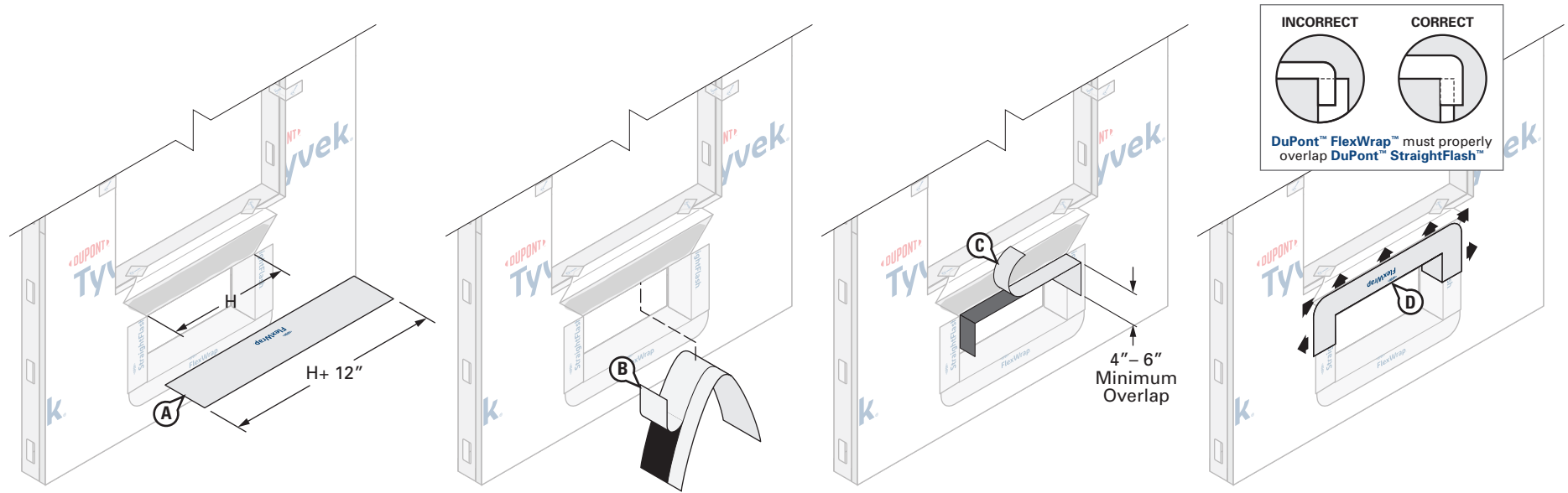

STEP 7

Install DuPont™ FlexWrap™ at the Head of PTAC Unit

- A. Cut **FlexWrap™** at least 8”– 12” **LONGER** than the width of rough opening head (H). Use roll widths sufficient to achieve a minimum of 1” adhesion **BEYOND** where the back of the PTAC unit sleeve will be located, ensuring 2”– 3” adhesion onto the face of the wall.
- B. Fold the **FlexWrap™** in half lengthwise to create a slight crease at the center. Remove the wide piece of release paper on one side of the fold. Align the inside edge of the narrow release paper with the face of the wall to ensure 2”– 3” of the **FlexWrap™** will be adhered to the face of the wall. Starting at the crease, adhere the **FlexWrap™** at the center of the horizontal portion of the head framing to ensure a minimum of 6” down each jamb. Adhere into rough opening at one corner and down the jamb. Remove the remaining release paper and repeat at opposite corner.
- C. Remove narrow release paper.
- D. Fan out the **FlexWrap™** at corners and adhere onto face of wall. Continue adhering onto face of wall along the head.

NOTE: DuPont™ Tyvek® Commercial Certified Installers may install a 3-piece head (and sill) detail for PTAC unit and window openings less than 6 ft. wide. Installers who **are not** DuPont™ Tyvek® Commercial Certified Installers should refer to the [Special Considerations](#) section for more information regarding the 3-piece head/sill detail. Contact your local DuPont Building Envelope Specialist for more information about the Certified Installer program.

Installation Methods for DuPont Self-Adhered Flashing Products Installed **AFTER** the DuPont™ Tyvek® WRB Packaged Terminal Air Conditioner (PTAC) Unit (Using “Wrap the Cavity” Method)

Option 1 – PTAC Rough Opening Minimum 8” below Window Rough Opening

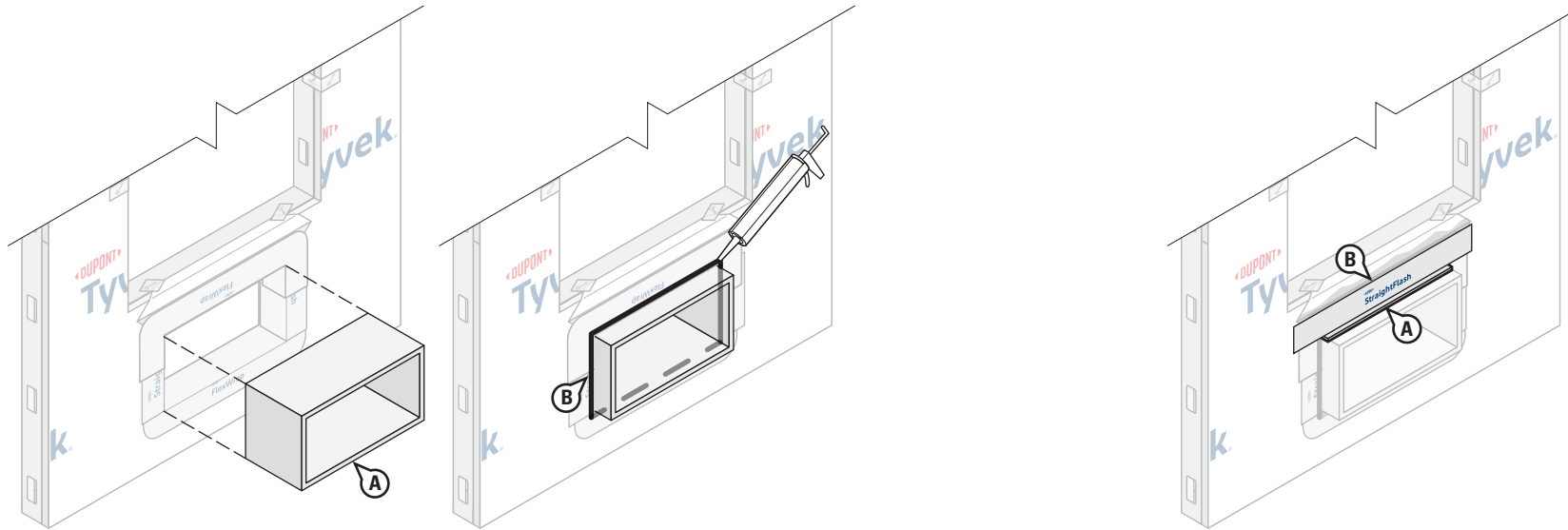

STEP 8

Install PTAC Unit

- Install PTAC Unit sleeve per manufacturer's installation instructions.
- Apply an exterior perimeter seal using backer rod and recommended sealant along the jambs and head of the PTAC opening. Refer to [Chemical Compatibility of Representative Building Sealants and Adhesives/Primers](#) for more information on recommended sealants.

STEP 9 – OPTIONAL

- When desired and as a best practice for high exposure areas, install metal drip cap above the head joint when specified.
- Apply a strip of 4" **DuPont™ StraightFlash™** over the drip cap.

Installation Methods for DuPont Self-Adhered Flashing Products Installed **AFTER** the DuPont™ Tyvek® WRB Packaged Terminal Air Conditioner (PTAC) Unit (Using “Wrap the Cavity” Method)

Option 1 – PTAC Rough Opening Minimum 8” below Window Rough Opening

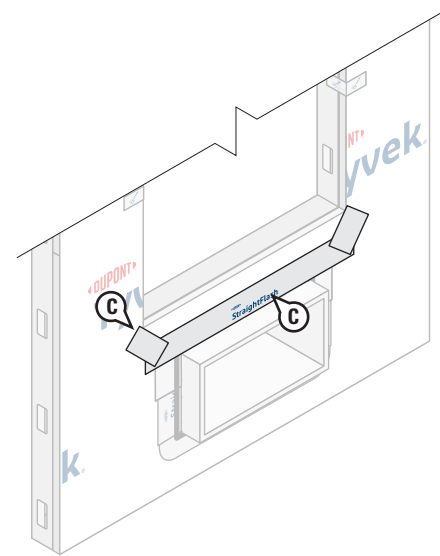
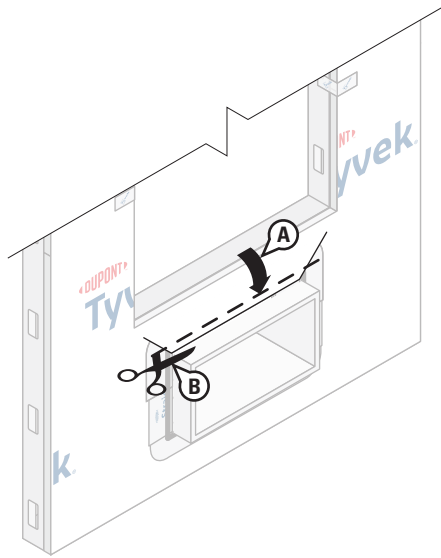

STEP 10

- A. Flip down upper flap of **Tyvek® WRB** so it lays flat across head flashing.
- B. Cut 1”– 2” strip of the **Tyvek® WRB** at lower horizontal edge of head flap.

- C. Terminate head flap as shown by continuously sealing the horizontal and then the diagonal seams with 4" **DuPont™ StraightFlash™**.

Installation Methods for DuPont Self-Adhered Flashing Products Installed AFTER the DuPont™ Tyvek® WRB Packaged Terminal Air Conditioner (PTAC) Unit (Using “Wrap the Cavity” Method)

Option 1 – PTAC Rough Opening Minimum 8” below Window Rough Opening

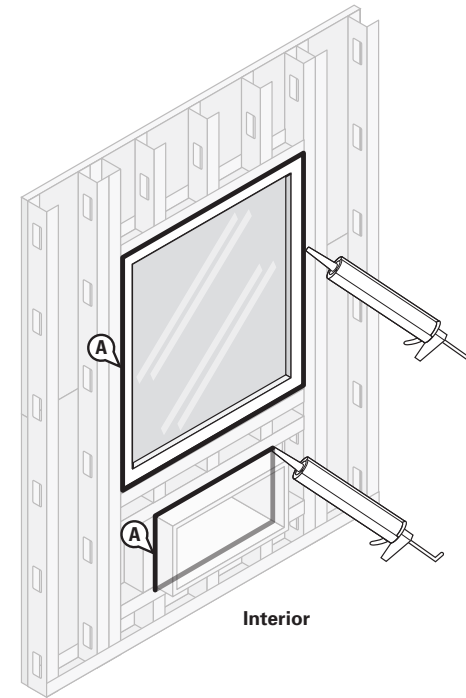
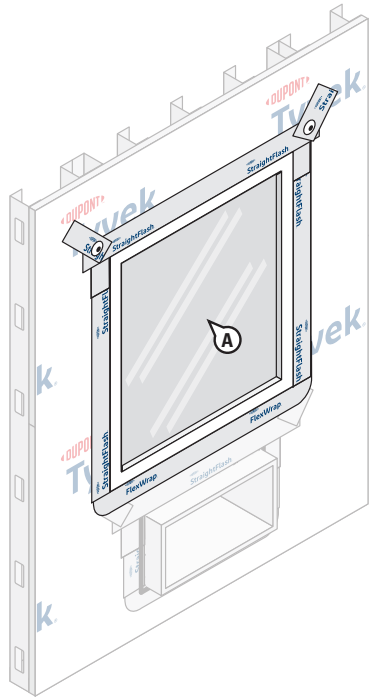

STEP 11

A. Prepare window rough opening, install window according to manufacturer’s instructions, and flash per the [Non-Flanged Window](#) details section in this guide.

NOTE: A non-flanged window is shown. If an integral flanged window is installed above the PTAC unit, follow the applicable section within this guide.

NOTE: For a more robust install, areas with extreme wind load exposures, or high performance testing use 4” **StraightFlash™** to seal the head flap and install additional mechanical fasteners through the flashing at the head flap and perimeter of window.

STEP 12

Final Step

A. Create a continuous perimeter seal using backer rod and recommended sealant or **Great Stuff Pro™ Window and Door Polyurethane Foam Sealant** around both the window and PTAC openings at the interior to resist air and water infiltration. When using **Great Stuff Pro™ Window and Door Polyurethane Foam Sealant** in perimeter openings less than 1/2”, apply using the plastic extension tip for the **Great Stuff Pro™ Dispenser Gun** during installation.

NOTE: For high performance installations exceeding ASTM E1677 wind loading pressures (10.8 psf, 65 mph equivalent structural load) and ASTM E331 water infiltration resistance of 6.24 psf, it is necessary to install sealant over the cured foam when using **Great Stuff Pro™ Window and Door Polyurethane Foam Sealant** or other recommended foam. Sealant should be installed over the foam between the window frame and rough opening around the entire interior perimeter. If **Great Stuff Pro™ Window and Door Polyurethane Foam Sealant** or other recommended foam extends **BEYOND** the window frame, shave the excess cured foam flush with the window frame before applying sealant. Avoid damaging the **DuPont Self-Adhered Flashing Product** or **Tyvek® WRB**.

Installation Methods for DuPont Self-Adhered Flashing Products Installed **AFTER** the DuPont™ Tyvek® WRB Packaged Terminal Air Conditioner (PTAC) Unit (Using “Wrap the Cavity” Method)

This method is for flashing/protecting the rough opening of a Packaged Terminal Air Conditioner (PTAC) Unit.

This method applies to the following products: DuPont™ StraightFlash™ and DuPont™ FlexWrap™

Option 2 – PTAC Rough Opening less than 8” below Window Rough Opening

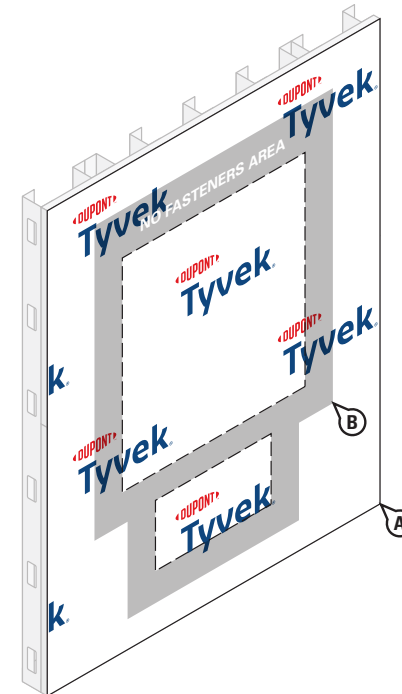
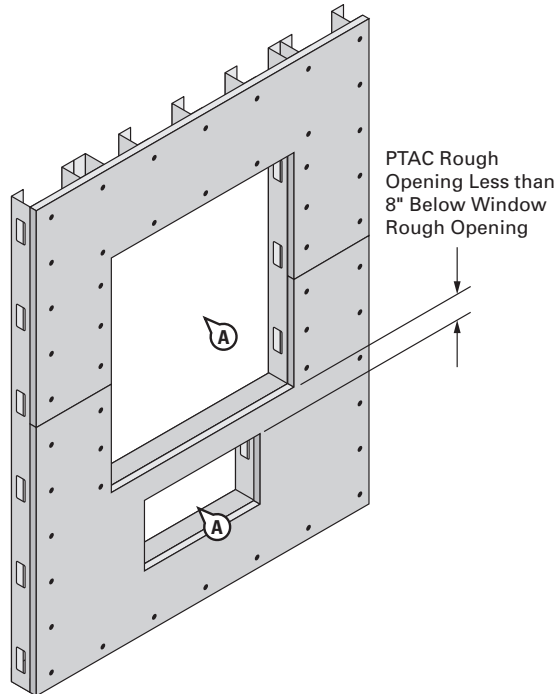

STEP 1

- A. Cut rough opening in sheathing for window and PTAC unit. Ensure that sheathing is cut flush with, or slightly below the sill framing to allow for positive drainage.

STEP 2

- A. Wrap wall as shown in the [DuPont™ Tyvek® WRB Installation Instructions](#) section in this guide.
- B. Do not install fasteners within 6” of the sills and jambs of the openings and within 9” of the head of the openings.

Installation Methods for DuPont Self-Adhered Flashing Products Installed **AFTER** the DuPont™ Tyvek® WRB Packaged Terminal Air Conditioner (PTAC) Unit (Using “Wrap the Cavity” Method)

Option 2 – PTAC Rough Opening less than 8” below Window Rough Opening

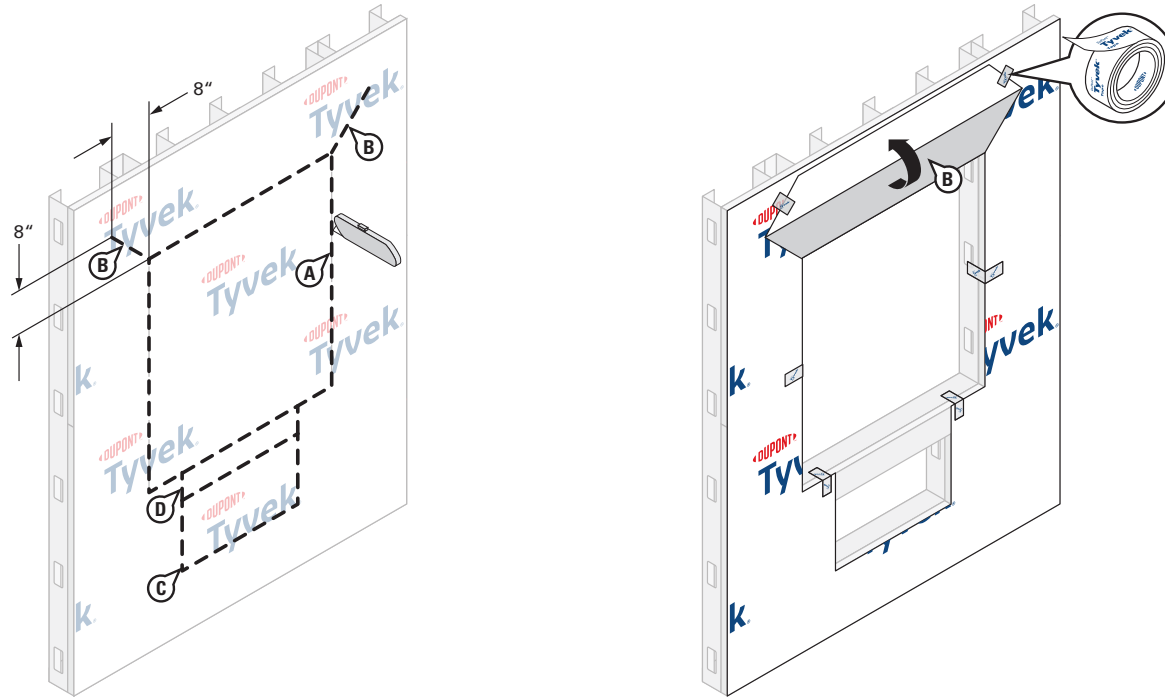

STEP 3

Prepare the Tyvek® WRB for Window and PTAC Installation

A. Using a flush cut (“O-Cut”), cut an opening in the Tyvek® WRB around the perimeter of the rough opening per the [Non-Flanged Window](#) details in this guide. Cuts should be made along the dashed indicated lines. (Ensure the Tyvek® WRB is cut flush with the sheathing and is not wrapped into the rough opening.)

NOTE: If an integral flanged window is installed above the PTAC Unit, follow the applicable detail in this guide.

B. Cut a head flap at a 45° angle to expose 8” of sheathing to allow for head flashing installation. Flip head flap up and temporarily secure with DuPont™ Tyvek® Tape.

ALTERNATE METHOD TO SECURE HEAD FLAPS: In lieu of temporarily taping, the head flap can be tucked under the Tyvek® WRB.

- C. Make a flush cut (“O-Cut”) in the Tyvek® WRB along the perimeter of the PTAC rough opening.
- D. Make two vertical cuts in the Tyvek® WRB above the PTAC rough opening to expose the sheathing in the area between the two rough openings. Cuts should align with jambs of the PTAC rough opening as shown.

Installation Methods for DuPont Self-Adhered Flashing Products Installed AFTER the DuPont™ Tyvek® WRB Packaged Terminal Air Conditioner (PTAC) Unit (Using “Wrap the Cavity” Method)

Option 2 – PTAC Rough Opening less than 8” below Window Rough Opening

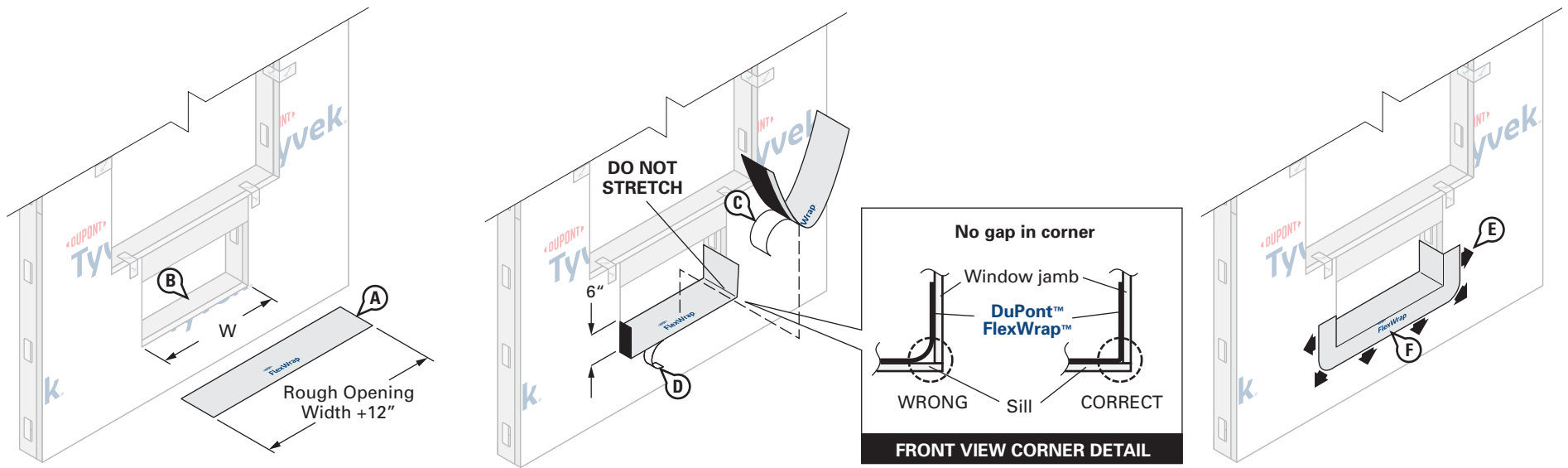

STEP 4

- Cut **DuPont™ FlexWrap™** at least 12” **LONGER** than width of rough opening (W). Use 6” **FlexWrap™** for 2” x 4” framing and 9” **FlexWrap™** for 2” x 6” framing.
- Inspect installation surface to ensure surface is free of dirt or substances that could interfere with adhesion as well as any sharp protrusions.
- Remove wide piece of release paper. Position on horizontal sill by aligning the inside edge of the narrow release paper with the face of the wall to ensure 2”– 3” of the **FlexWrap™** will be adhered to the face of the wall with a minimum of 6” up each jamb. Adhere into rough opening.
- Remove narrow release paper.
- Fan out the **FlexWrap™** at corners and adhere onto face of wall. Continue adhering onto face of wall along sill.
- Firmly press sill flashing to ensure full adhesion on all surfaces. Eliminate wrinkles and bubbles by smoothing surface and repositioning as necessary.

Installation Methods for DuPont Self-Adhered Flashing Products Installed AFTER the DuPont™ Tyvek® WRB Packaged Terminal Air Conditioner (PTAC) Unit (Using “Wrap the Cavity” Method)

Option 2 – PTAC Rough Opening less than 8” below Window Rough Opening

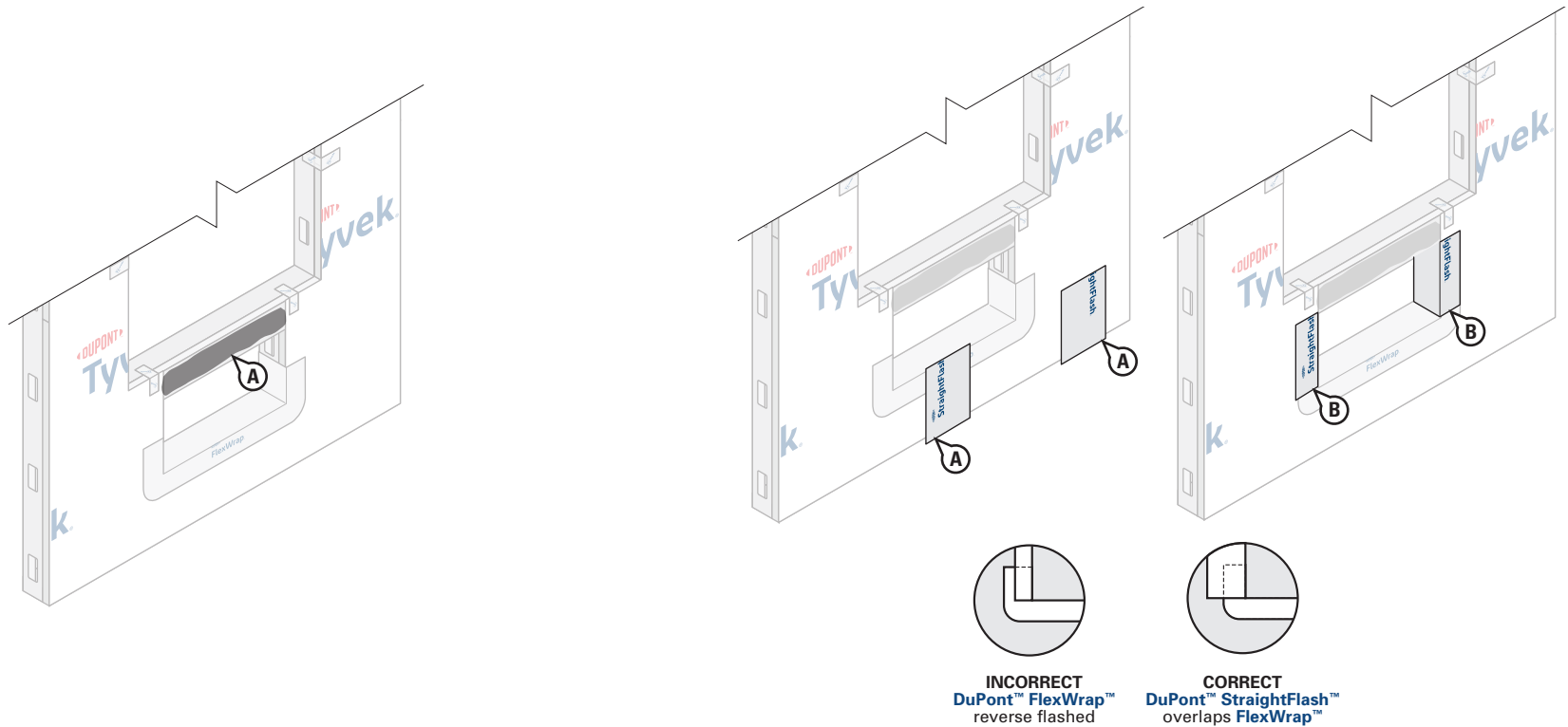

STEP 5

- Apply a recommended adhesive/primer to the exposed sheathing along the head of the rough opening for the PTAC Unit. Refer to [Chemical Compatibility of Representative Building Sealants and Adhesives/Primers](#) for more information on recommended adhesives/primers.

STEP 6

- Cut two pieces of 9" DuPont™ StraightFlash™ the height of the rough opening for the PTAC Unit. PTAC Unit Jamb flashing should be long enough to overlap the sill flashing by at least 2" and be overlapped by future head flashing by at least 2".
- Wrap the StraightFlash™ into the rough opening at each jamb and onto wall face. As a general reference, the flashing should align with the interior edge of the jamb framing.

Installation Methods for DuPont Self-Adhered Flashing Products Installed **AFTER** the DuPont™ Tyvek® WRB Packaged Terminal Air Conditioner (PTAC) Unit (Using “Wrap the Cavity” Method)

Option 2 – PTAC Rough Opening less than 8” below Window Rough Opening

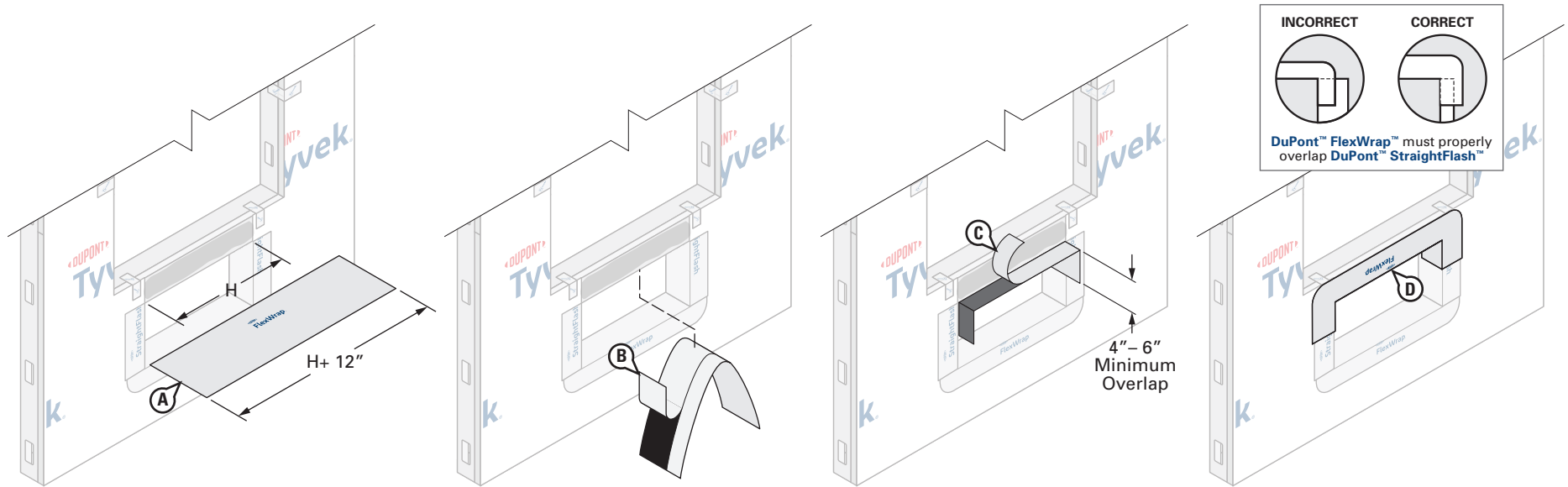

STEP 7

Install DuPont™ FlexWrap™ at the Head of PTAC Unit

- Cut **FlexWrap™** at least 8”– 12” **LONGER** than the width of rough opening head (H). Use roll widths sufficient to achieve a minimum of 1” adhesion **BEYOND** where the back of the PTAC unit sleeve will be located, ensuring 2”– 3” adhesion onto the face of the wall.
- Fold the **FlexWrap™** in half lengthwise to create a slight crease at the center. Remove the wide piece of release paper on one side of the fold. Align the inside edge of the narrow release paper with the face of the wall to ensure 2”– 3” of the **FlexWrap™** will be adhered to the face of the wall. Starting at the crease, adhere the **FlexWrap™** at the center of the horizontal portion of the head framing to ensure a minimum of 6” down each jamb. Adhere into rough opening at one corner and down the jamb. Remove the remaining release paper and repeat at opposite corner.
- Remove narrow release paper.
- Fan out the **FlexWrap™** at corners and adhere onto face of wall. Continue adhering onto face of wall along the head.

NOTE: DuPont™ Tyvek® Commercial Certified Installers may install a 3-piece head (and sill) detail for PTAC unit and window openings less than 6 ft. wide. Installers who **are not** DuPont™ Tyvek® Commercial Certified Installers should refer to the [Special Considerations](#) section for more information regarding the 3-piece head/sill detail. Contact your local DuPont Building Envelope Specialist for more information about the Certified Installer program.

Installation Methods for DuPont Self-Adhered Flashing Products Installed **AFTER** the DuPont™ Tyvek® WRB Packaged Terminal Air Conditioner (PTAC) Unit (Using “Wrap the Cavity” Method)

Option 2 – PTAC Rough Opening less than 8” below Window Rough Opening

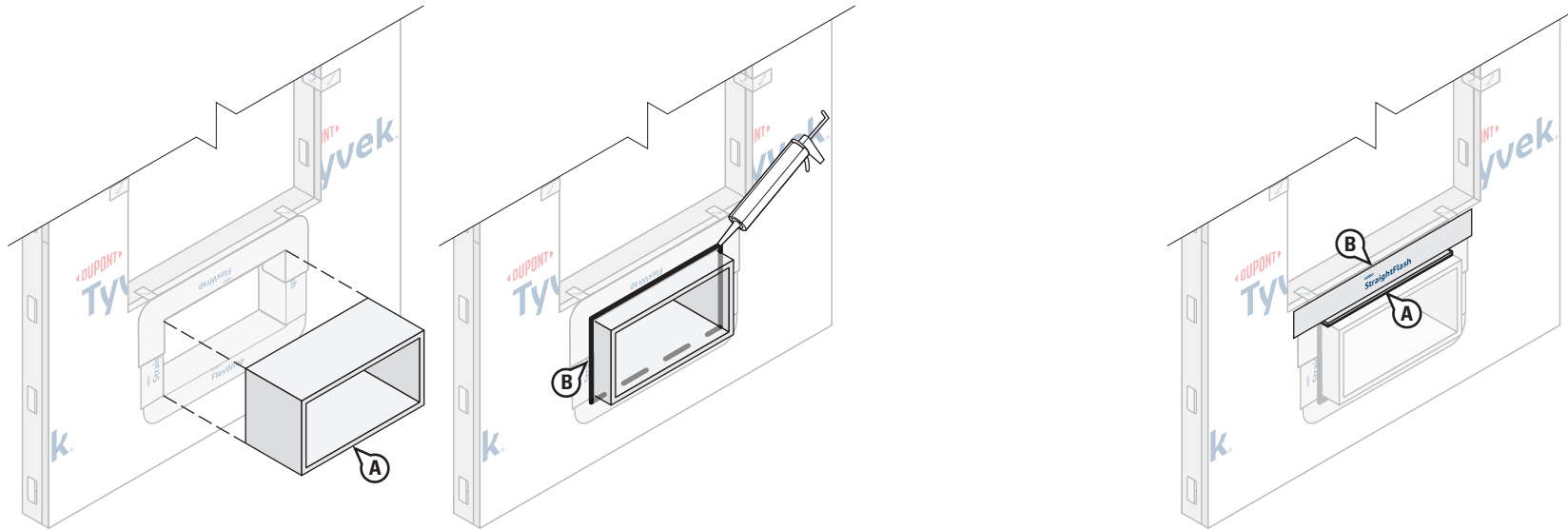

STEP 8

Install PTAC Unit

- A. Install PTAC Unit sleeve per manufacturer’s installation instructions.
- B. Apply an exterior perimeter seal using backer rod and recommended sealant along the jambs and head of the PTAC opening. Refer to [Chemical Compatibility of Representative Building Sealants and Adhesives/Primers](#) for more information on recommended sealants.

STEP 9

Only required when FlexWrap™ head piece does not fully cover exposed sheathing between rough openings and/or the drip cap if installed.

- A. Cut a piece of **DuPont™ StraightFlash™** long enough to extend min. 2” **BEYOND** each end of **FlexWrap™** PTAC head flashing. Install the cut piece of flashing so top edge is flush with the window sill and is centered along the **FlexWrap™** PTAC head flashing.

Installation Methods for DuPont Self-Adhered Flashing Products Installed AFTER the DuPont™ Tyvek® WRB Packaged Terminal Air Conditioner (PTAC) Unit (Using “Wrap the Cavity” Method)

Option 2 – PTAC Rough Opening less than 8” below Window Rough Opening

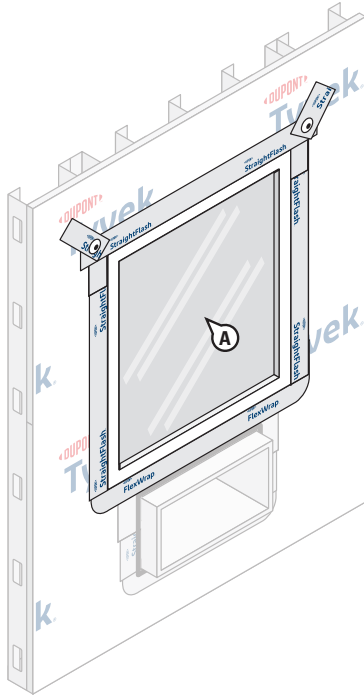

STEP 10

A. Prepare window rough opening, install window according to manufacturer’s instructions, and flash per the [Non-Flanged Window](#) details section in this guide.

NOTE: A non-flanged window is shown. If an integral flanged window is installed above the PTAC unit, follow the applicable section within this guide.

NOTE: For a more robust install, areas with extreme wind load exposures, or high performance testing use 4” **StraightFlash™** to seal the head flap and install additional mechanical fasteners through the flashing at the head flap and perimeter of window.

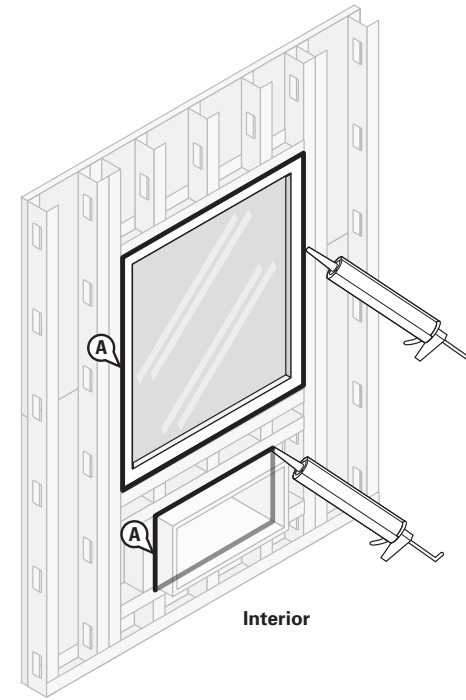

STEP 12

Final Step

A. Create a continuous perimeter seal using backer rod and recommended sealant or **Great Stuff Pro™ Window and Door Polyurethane Foam Sealant Sealant** around both the window and PTAC openings at the interior to resist air and water infiltration. When using **Great Stuff Pro™ Window and Door Polyurethane Foam Sealant** in perimeter openings less than 1/2”, apply using the plastic extension tip for the **Great Stuff Pro™ Dispenser Gun** during installation.

NOTE: For high performance installations exceeding ASTM E1677 wind loading pressures (10.8 psf, 65 mph equivalent structural load) and ASTM E331 water infiltration resistance of 6.24 psf, it is necessary to install sealant over the cured foam when using **Great Stuff Pro™ Window and Door Polyurethane Foam Sealant** or other recommended foam. Sealant should be installed over the foam between the window frame and rough opening around the entire interior perimeter. If **Great Stuff Pro™ Window and Door Polyurethane Foam Sealant** or other recommended foam extends **BEYOND** the window frame, shave the excess cured foam flush with the window frame before applying sealant. Avoid damaging the **DuPont Self-Adhered Flashing Product** or **Tyvek® WRB**.

Installation Methods for DuPont Self-Adhered Flashing Products Installed AFTER the DuPont™ Tyvek® WRB Packaged Terminal Air Conditioner (PTAC) Unit (Using DuPont™ VersaFlange™)

This method can be used to flash Packaged Terminal Air Conditioner (PTAC) Unit sleeves. Ensure **VersaFlange™** logo side faces the exterior. Use of **VersaFlange™** requires a smooth-framed PTAC sleeve for proper adhesion to the frame.

This method applies to the following products: DuPont™ VersaFlange™, DuPont™ StraightFlash™, DuPont™ FlexWrap™, and DuPont™ FlexWrap™ EZ

Option 1 – PTAC Rough Opening Minimum 8” below Window Rough Opening

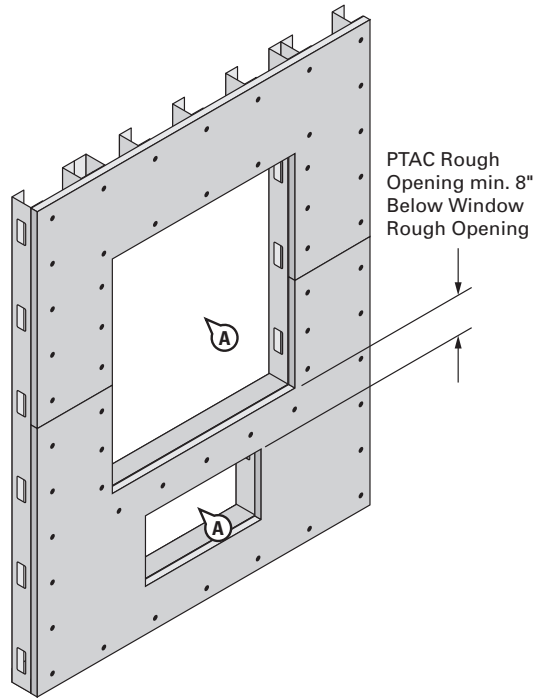

STEP 1

A. Cut rough opening in sheathing for window and PTAC. Ensure that sheathing is cut flush with, or slightly below the sill framing to allow for positive drainage.

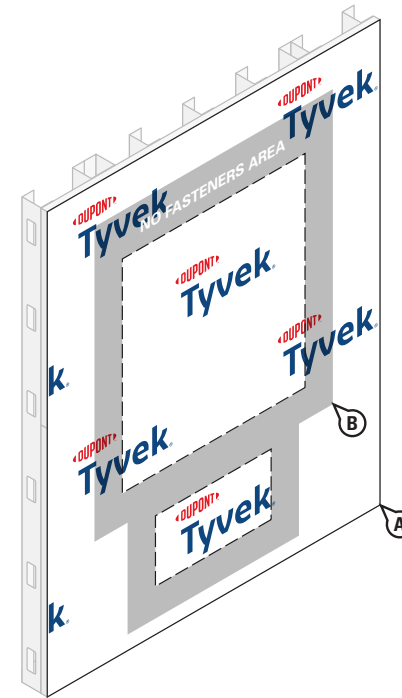

STEP 2

- A. Wrap wall as shown in the [DuPont™ Tyvek® WRB Installation Instructions](#) section in this guide.
- B. Do not install fasteners within 6” of the sills and jambs of the openings and within 9” of the head of the openings.

Installation Methods for DuPont Self-Adhered Flashing Products Installed AFTER the DuPont™ Tyvek® WRB Packaged Terminal Air Conditioner (PTAC) Unit (Using DuPont™ VersaFlange™)

Option 1 – PTAC Rough Opening Minimum 8” below Window Rough Opening

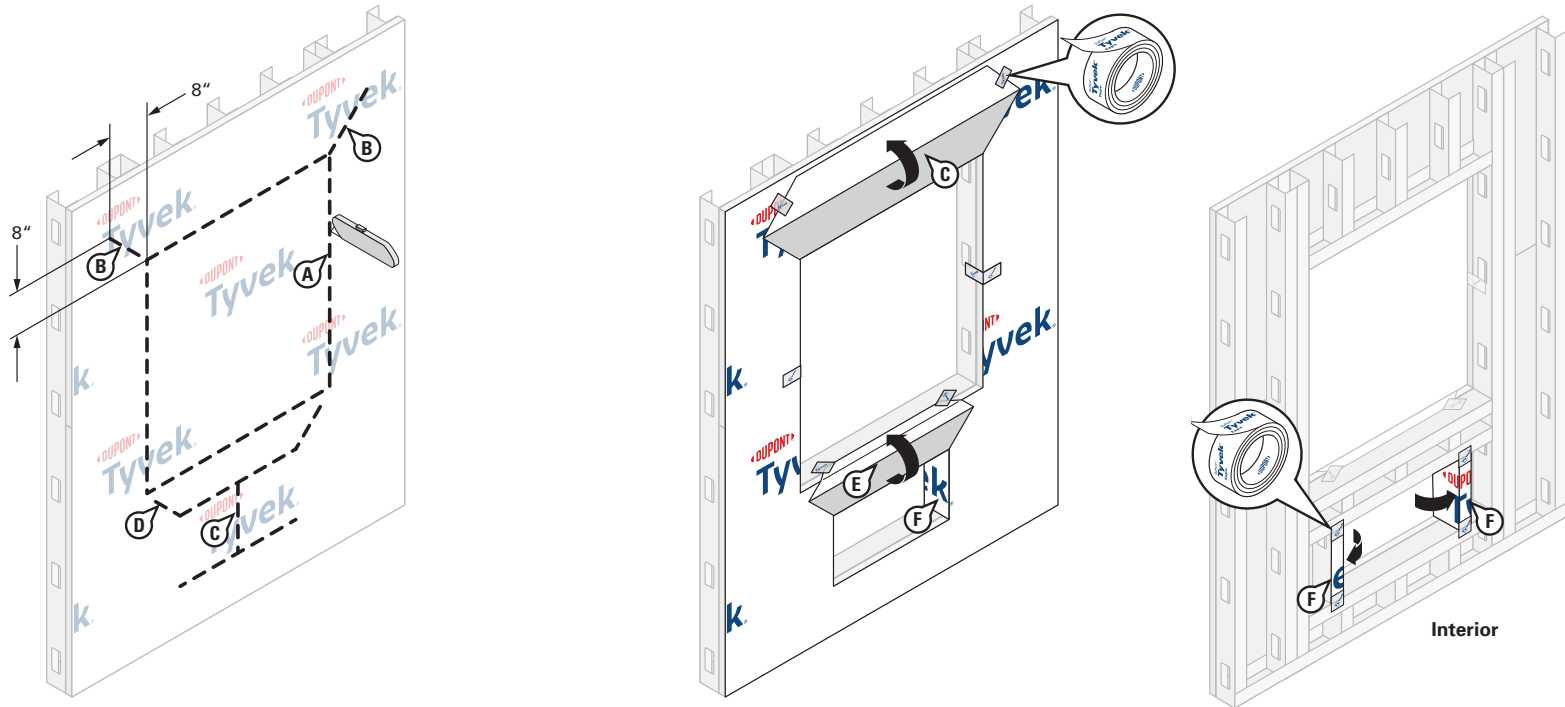

STEP 3

Prepare the Tyvek® WRB for Window and PTAC Installation

A. Using a flush cut (“O-Cut”), cut an opening in the Tyvek® WRB around the perimeter of the rough opening per the [Non-Flanged Window](#) details in this guide. Cuts should be made along the dashed indicated lines. (Ensure the Tyvek® WRB is cut flush with the sheathing and is not wrapped into the rough opening.)

NOTE: If an integral flanged window is installed above the PTAC Unit, follow the applicable detail in this guide.

B. Cut a head flap at a 45° angle to expose 8” of sheathing to allow for head flashing installation. Flip head flap up and temporarily secure with DuPont™ Tyvek® Tape.

ALTERNATE METHOD TO SECURE HEAD FLAPS: In lieu of temporarily taping, the head flap can be tucked under the Tyvek® WRB.

C. Make an “I-Cut” in the Tyvek® WRB at the PTAC rough opening.

D. Cut two 45 degree slits up and away from the PTAC rough opening, extending from the corner of the head. Cuts should extend far enough to ensure DuPont™ VersaFlange™ that will be installed in a future step can be installed to the exposed sheathing at the head.

E. Flip head flap up and temporarily secure with Tyvek® Tape.

F. Fold side flaps into rough openings of the window and the PTAC and secure to inside wall. Cut off excess flaps if desired.

Installation Methods for DuPont Self-Adhered Flashing Products Installed AFTER the DuPont™ Tyvek® WRB Packaged Terminal Air Conditioner (PTAC) Unit (Using DuPont™ VersaFlange™)

Option 1 – PTAC Rough Opening Minimum 8” below Window Rough Opening

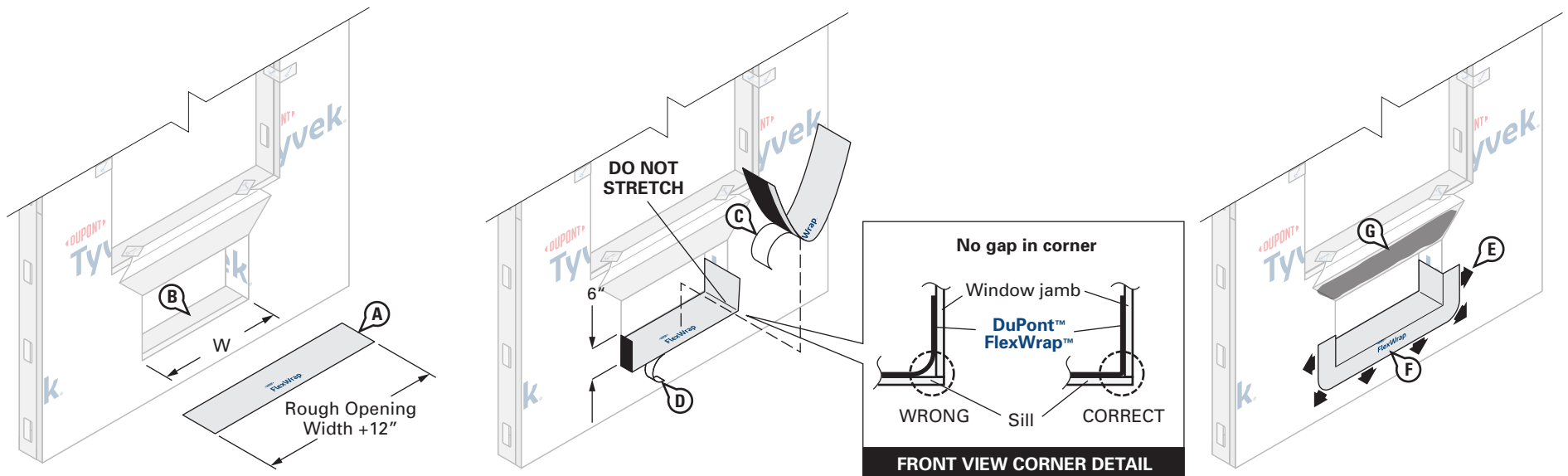

STEP 4

- Cut **DuPont™ FlexWrap™** at least 12" **LONGER** than width of rough opening (W). Use 6" **FlexWrap™** for 2" x 4" framing and 9" **FlexWrap™** for 2" x 6" framing.
- Inspect installation surface to ensure surface is free of dirt or substances that could interfere with adhesion as well as any sharp protrusions.
- Remove wide piece of release paper. Position on horizontal sill by aligning the inside edge of the narrow release paper with the face of the wall to ensure 2"– 3" of the **FlexWrap™** will be adhered to the face of the wall with a minimum of 6" up each jamb. Adhere into rough opening.
- Remove narrow release paper.
- Fan out the **FlexWrap™** at corners and adhere onto face of wall. Continue adhering onto face of wall along sill.
- Firmly press sill flashing to ensure full adhesion on all surfaces. Eliminate wrinkles and bubbles by smoothing surface and repositioning as necessary.
- Apply a recommended adhesive/primer to exposed sheathing. Refer to [Chemical Compatibility of Representative Building Sealants and Adhesives/Primers](#) for more information on recommended adhesives/primers.

NOTE: DuPont™ Tyvek® Commercial Certified Installers may install a 3-piece head (and sill) detail for PTAC unit and window openings less than 6 ft. wide. Installers who **are not** DuPont™ Tyvek® Commercial Certified Installers should refer to the [Special Considerations](#) section for more information regarding the 3-piece head/sill detail. Contact your local DuPont Building Envelope Specialist for more information about the Certified Installer program.

Installation Methods for DuPont Self-Adhered Flashing Products Installed AFTER the DuPont™ Tyvek® WRB Packaged Terminal Air Conditioner (PTAC) Unit (Using DuPont™ VersaFlange™)

Option 1 – PTAC Rough Opening Minimum 8” below Window Rough Opening

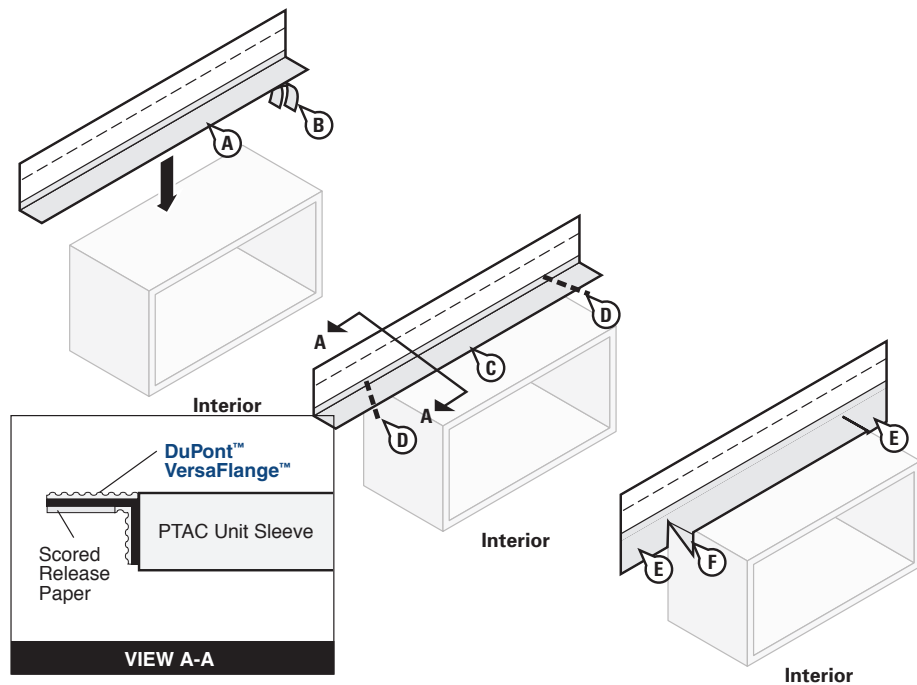

STEP 5

Prepare PTAC Unit Sleeve using DuPont™ VersaFlange™

- Prepare head flashing by cutting a piece of **VersaFlange™** at least 12” **LONGER** than the head length.
- Remove the release paper from one side of the **VersaFlange™**.
- Center the flashing along the length of the PTAC unit sleeve and position so that it contacts the PTAC unit sleeve. Use firm hand pressure or a j-roller to ensure proper adhesion to the sleeve.
- Beginning at the junction of the jamb and head and away from the corners, cut the **VersaFlange™** at a 45° angle.
- Fold the newly created flashing flaps down parallel to the PTAC unit sleeve.
- Fold remaining head flashing flaps down onto the jamb.

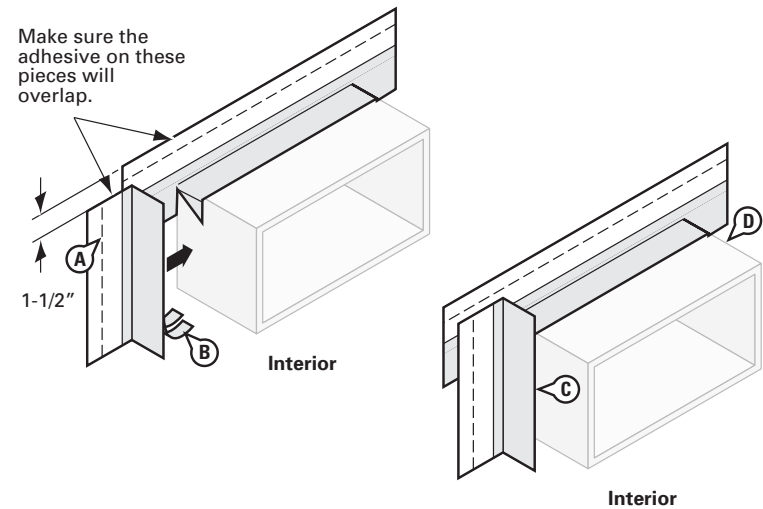

STEP 6

- Prepare jamb flashing by cutting a piece of **VersaFlange™** at least 6” **LONGER** than the jamb length.
- Remove the release paper from one side of the **VersaFlange™**.
- Position the **VersaFlange™** so that it contacts the PTAC unit sleeve up to the exterior face of the sleeve. Ensure that the jamb flashing is positioned 1 1/2” below top of head flashing. **Jamb flashing adhesive must come in contact with head flashing adhesive and overlap by one inch.**
- Repeat on opposite jamb.

Installation Methods for DuPont Self-Adhered Flashing Products Installed AFTER the DuPont™ Tyvek® WRB Packaged Terminal Air Conditioner (PTAC) Unit (Using DuPont™ VersaFlange™)

Option 1 – PTAC Rough Opening Minimum 8” below Window Rough Opening

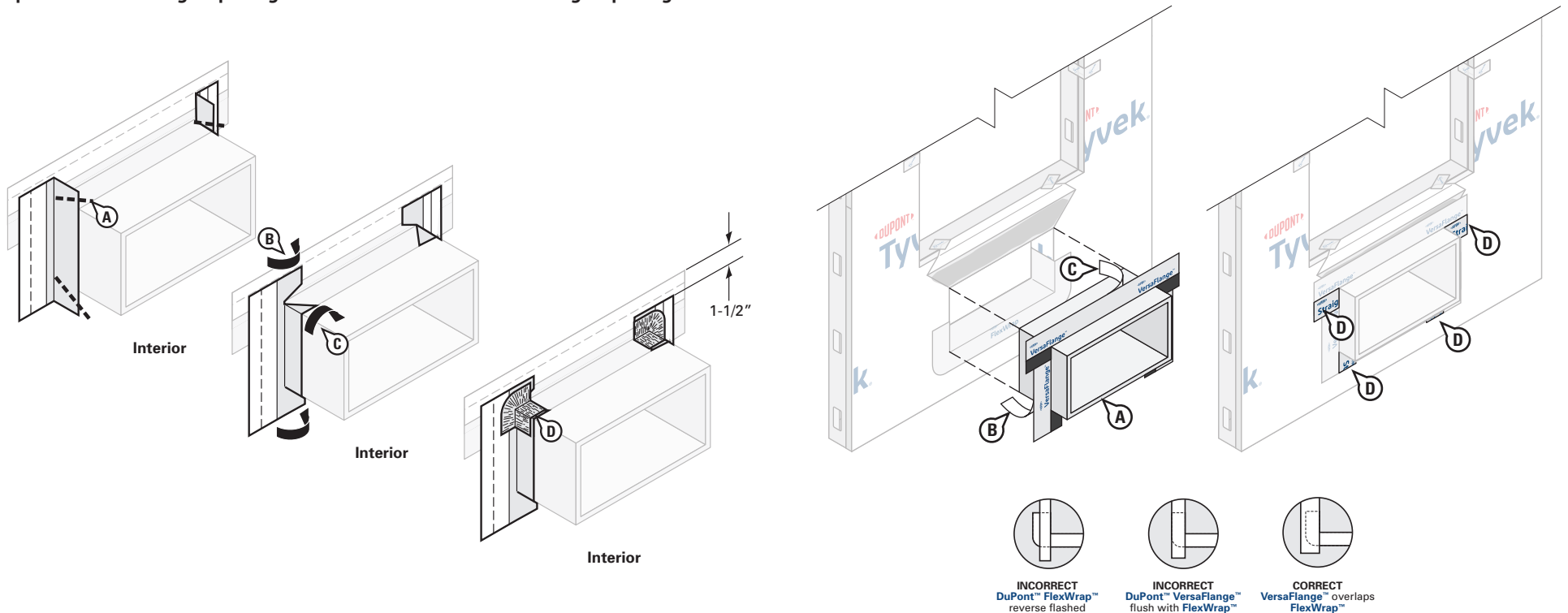

STEP 7

- Beginning at the junction of the jambs and the head, and away from the corners, cut the **DuPont™ VersaFlange™** at a 45° angle. Repeat the procedure at the junction of the sill and jambs.
- In order to overlap jamb adhesive to the head flashing adhesive, temporarily pull back release liner on the head flashing. Fold cut jamb flashing parallel to the PTAC unit sleeve so that the jamb flashing lies flat onto the head flashing. Fold the head flashing release liner back down to protect any remaining exposed butyl along the head flashing prior to installation of the PTAC unit.
- Fold remaining jamb flashing flaps down at all corners and adhere to the PTAC unit sleeve.
- Cut two 3" x 3" pieces of **DuPont™ FlexWrap™**, or two 3" pieces of **DuPont™ FlexWrap™ EZ**, and add patches to corners of the PTAC unit sleeve.

STEP 8

- Install the PTAC unit sleeve per manufacturer's instructions.
 - Remove the remaining release paper from the **VersaFlange™** jamb flashing and press firmly to adhere the butyl adhesive to the **Tyvek® WRB**.
 - Remove the release paper at the head and adhere the **VersaFlange™** to the wall surface.
- NOTE:** Do not reverse shingle. **VersaFlange™** must overlap **FlexWrap™** and adhere to the substrate.
- OPTIONAL:** Cover exposed butyl with **DuPont™ StraightFlash™**, or **DuPont™ Tyvek® Tape**.

Installation Methods for DuPont Self-Adhered Flashing Products Installed **AFTER** the DuPont™ Tyvek® WRB Packaged Terminal Air Conditioner (PTAC) Unit (Using DuPont™ VersaFlange™)

Option 1 – PTAC Rough Opening Minimum 8” below Window Rough Opening

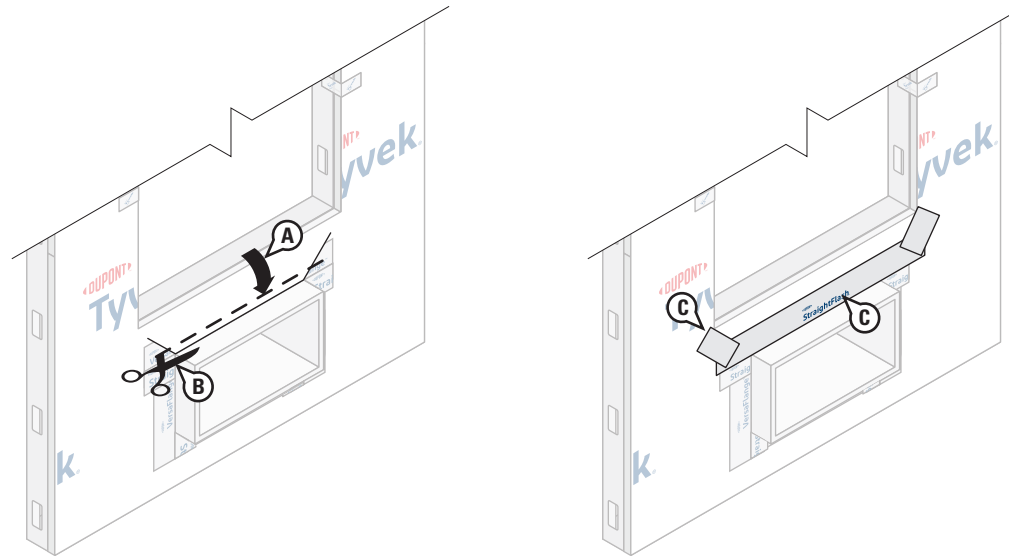

STEP 9

- A. Flip down upper flap of **Tyvek® WRB** so it lays flat across head flashing.
- B. Cut 1”– 2” strip of the **Tyvek® WRB** at lower horizontal edge of head flap.
- C. Terminate head flap as shown by continuously sealing the horizontal and then the diagonal seams with 4" **DuPont™ StraightFlash™**. If additional drainage is desired, skip-sealing at head with a maximum of two (2) 2” gaps for every 3’ of window is acceptable **if an air barrier is not required**.

Installation Methods for DuPont Self-Adhered Flashing Products Installed **AFTER** the DuPont™ Tyvek® WRB Packaged Terminal Air Conditioner (PTAC) Unit (Using DuPont™ VersaFlange™)

Option 1 – PTAC Rough Opening Minimum 8” below Window Rough Opening

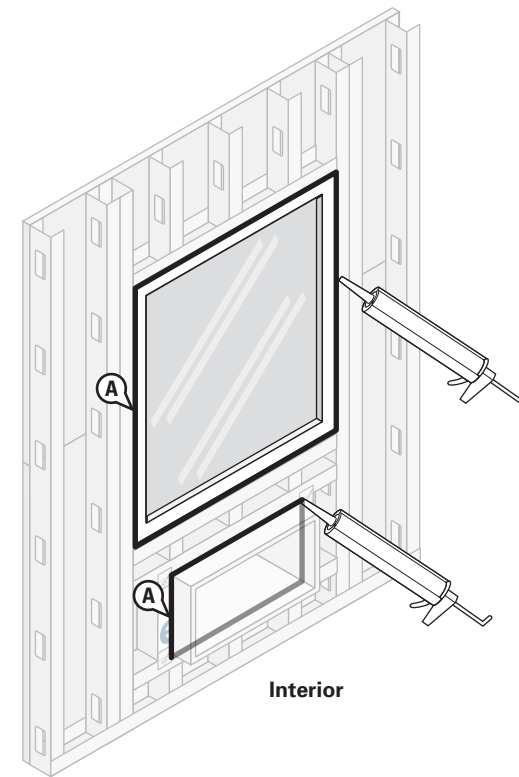
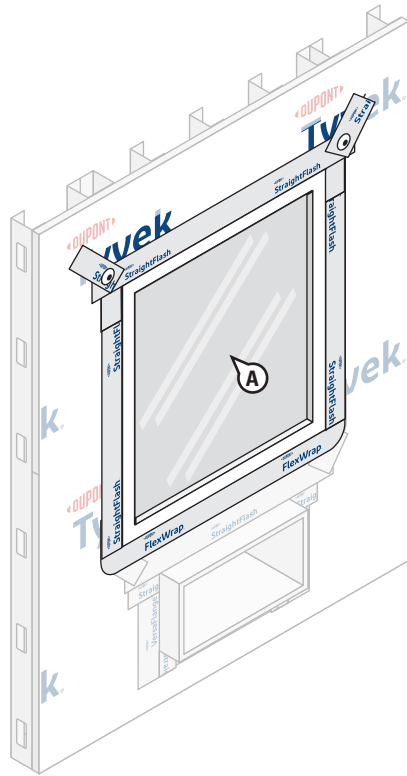

STEP 10

A. Prepare window rough opening, install window according to manufacturer's instructions, and flash per the [Non-Flanged Window](#) details section in this guide.

NOTE: A non-flanged window is shown. If an integral flanged window is installed above the PTAC unit, follow the applicable section within this guide.

NOTE: For a more robust install, areas with extreme wind load exposures, or high performance testing use 4" **StraightFlash™** to seal the head flap and install additional mechanical fasteners through the flashing at the head flap and perimeter of window.

STEP 11

A. Create a continuous perimeter seal using backer rod and recommended sealant or **Great Stuff Pro™ Window and Door Polyurethane Foam Sealant** around both the window and PTAC openings at the interior to resist air and water infiltration. When using **Great Stuff Pro™ Window and Door Polyurethane Foam Sealant** in perimeter openings less than 1/2", apply using the plastic extension tip for the **Great Stuff Pro™ Dispenser Gun** during installation.

NOTE: For high performance installations exceeding ASTM E1677 wind loading pressures (10.8 psf, 65 mph equivalent structural load) and ASTM E331 water infiltration resistance of 6.24 psf, it is necessary to install sealant over the cured foam when using **Great Stuff Pro™ Window and Door Polyurethane Foam Sealant** or other recommended foam. Sealant should be installed over the foam between the window frame and rough opening around the entire interior perimeter. If **Great Stuff Pro™ Window and Door Polyurethane Foam Sealant** or other recommended foam extends **BEYOND** the window frame, shave the excess cured foam flush with the window frame before applying sealant. Avoid damaging the **DuPont Self-Adhered Flashing Product** or **Tyvek® WRB**.

Installation Methods for DuPont Self-Adhered Flashing Products Installed AFTER the DuPont™ Tyvek® WRB Packaged Terminal Air Conditioner (PTAC) Unit (Using DuPont™ VersaFlange™)

This method can be used to flash Packaged Terminal Air Conditioner (PTAC) Unit sleeves. Ensure **DuPont™ VersaFlange™** logo side faces the exterior. Use of **DuPont™ VersaFlange™** requires a smooth-framed PTAC sleeve for proper adhesion to the frame.

This method applies to the following products: DuPont™ Flashing Tape, DuPont™ StraightFlash™, DuPont™ VersaFlange™, DuPont™ FlexWrap™, and DuPont™ FlexWrap™ EZ

Option 2 – PTAC Rough Opening Less than 8” below Window Rough Opening

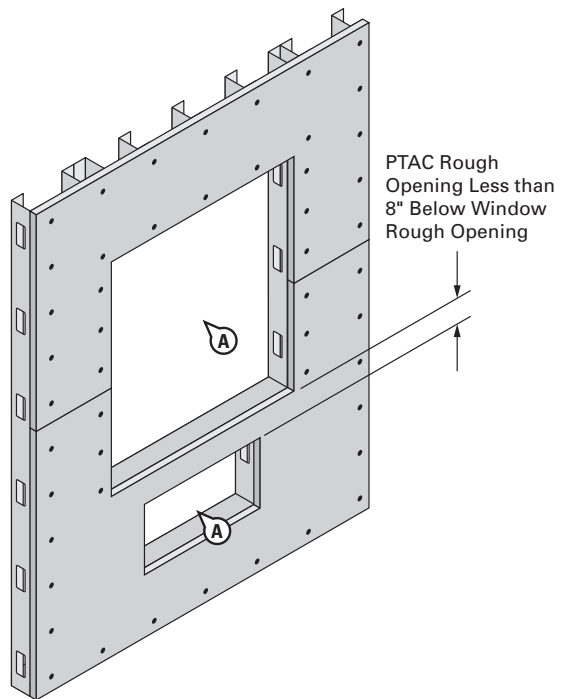

STEP 1

- A. Cut rough opening in sheathing for window and PTAC. Ensure that sheathing is cut flush with, or slightly below the sill framing to allow for positive drainage.

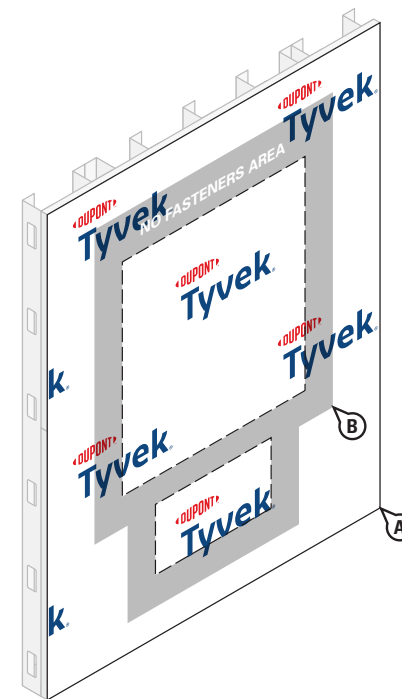

STEP 2

- A. Wrap wall as shown in the [DuPont™ Tyvek® WRB Installation Instructions](#) section in this guide.
- B. Do not install fasteners within 6" of the sills and jambs of the openings and within 9" of the head of the openings.

Installation Methods for DuPont Self-Adhered Flashing Products Installed AFTER the DuPont™ Tyvek® WRB Packaged Terminal Air Conditioner (PTAC) Unit (Using DuPont™ VersaFlange™)

Option 2 – PTAC Rough Opening Less than 8” below Window Rough Opening

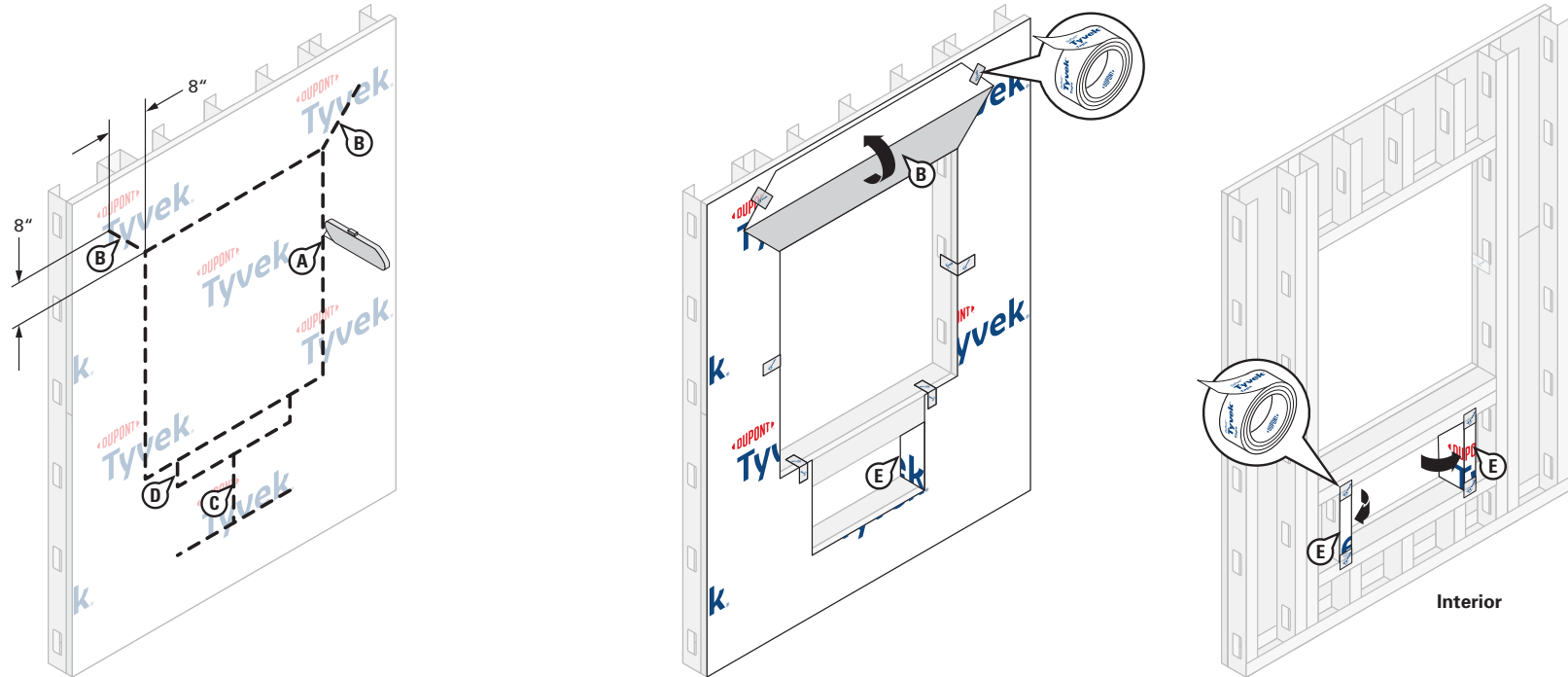

STEP 3

Prepare the Tyvek® WRB for Window and PTAC Installation

A. Using a flush cut (“O-Cut”), cut an opening in the Tyvek® WRB around the perimeter of the rough opening per the [Non-Flanged Window](#) details in this guide. Cuts should be made along the dashed indicated lines. (Ensure the Tyvek® WRB is cut flush with the sheathing and is not wrapped into the rough opening.)

NOTE: If an integral flanged window is installed above the PTAC Unit, follow the applicable detail in this guide.

B. Cut a head flap at a 45° angle to expose 8” of sheathing to allow for head flashing installation. Flip head flap up and temporarily secure with DuPont™ Tyvek® Tape..

ALTERNATE METHOD TO SECURE HEAD FLAPS: In lieu of temporarily taping, the head flap can be tucked under the Tyvek® WRB.

C. Make an “I-Cut” in the Tyvek® WRB at the PTAC rough opening.

D. Make two vertical cuts in the Tyvek® WRB above the PTAC rough opening to expose the sheathing in the area between the two rough openings. Cuts should align with jambs of the PTAC rough opening as shown.

E. Fold side flaps into rough openings of the window and the PTAC and secure to inside wall. Cut off excess flaps if desired.

Installation Methods for DuPont Self-Adhered Flashing Products Installed **AFTER** the DuPont™ Tyvek® WRB Packaged Terminal Air Conditioner (PTAC) Unit (Using DuPont™ VersaFlange™)

Option 2 – PTAC Rough Opening Less than 8” below Window Rough Opening

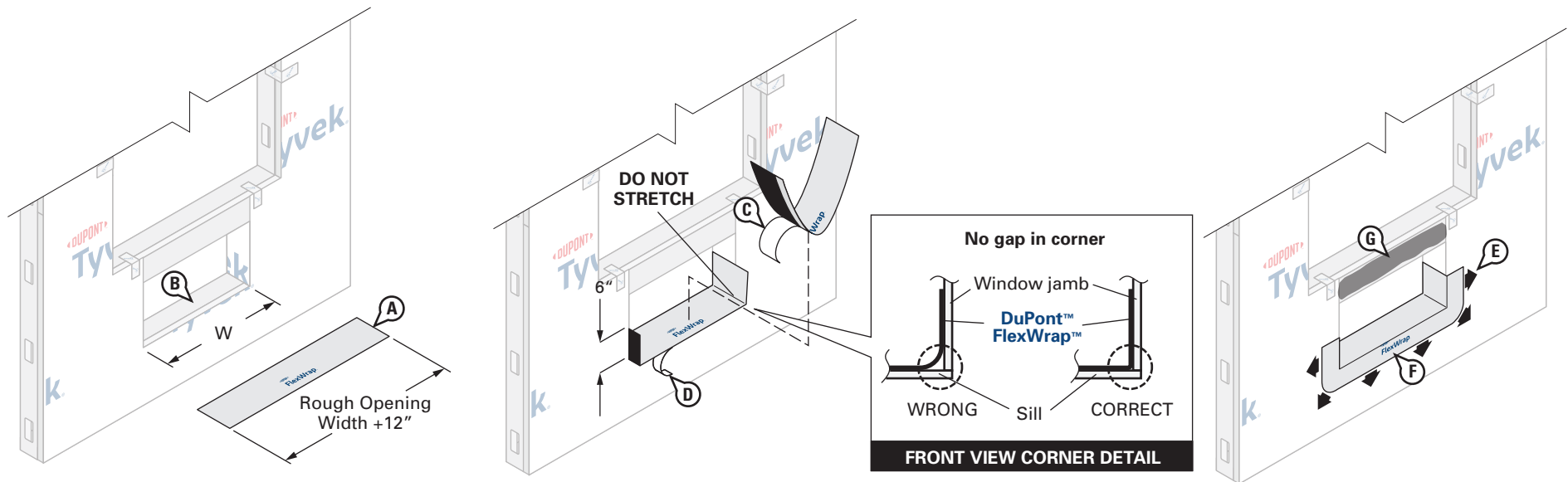

STEP 4

- Cut **DuPont™ FlexWrap™** at least 12” **LONGER** than width of rough opening (W). Use 6” **FlexWrap™** for 2” x 4” framing and 9” **FlexWrap™** for 2” x 6” framing.
- Inspect installation surface to ensure surface is free of dirt or substances that could interfere with adhesion as well as any sharp protrusions.
- Remove wide piece of release paper. Position on horizontal sill by aligning the inside edge of the narrow release paper with the face of the wall to ensure 2”– 3” of the **FlexWrap™** will be adhered to the face of the wall with a minimum of 6” up each jamb. Adhere into rough opening.
- Remove narrow release paper.
- Fan out the **FlexWrap™** at corners and adhere onto face of wall. Continue adhering onto face of wall along sill.
- Firmly press sill flashing to ensure full adhesion on all surfaces. Eliminate wrinkles and bubbles by smoothing surface and repositioning as necessary.
- Apply a recommended adhesive/primer to exposed sheathing. Refer to [Chemical Compatibility of Representative Building Sealants and Adhesives/Primers](#) for more information on recommended adhesives/primers.

NOTE: DuPont™ Tyvek® Commercial Certified Installers may install a 3-piece sill detail for PTAC unit and window openings less than 6 ft. wide. Installers who **are not** DuPont™ Tyvek® Commercial Certified Installers should refer to the [Special Considerations](#) section for more information regarding the 3-piece head/sill detail. Contact your local DuPont Building Envelope Specialist for more information about the Certified Installer program.

Installation Methods for DuPont Self-Adhered Flashing Products Installed AFTER the DuPont™ Tyvek® WRB Packaged Terminal Air Conditioner (PTAC) Unit (Using DuPont™ VersaFlange™)

Option 2 – PTAC Rough Opening Less than 8” below Window Rough Opening

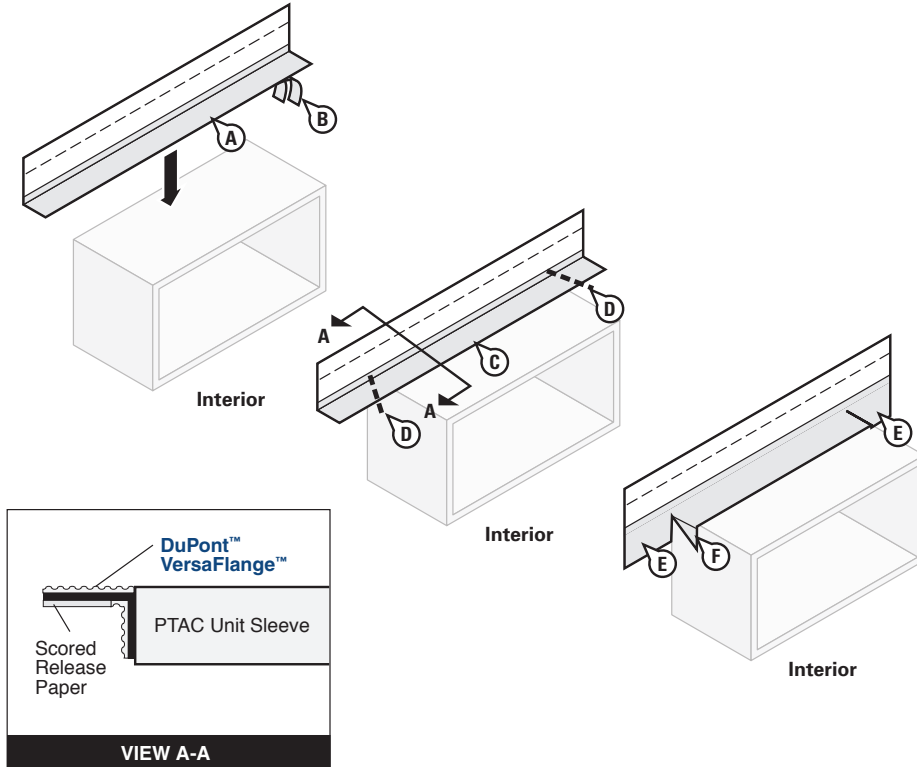

STEP 5

Prepare PTAC Unit Sleeve using DuPont™ VersaFlange™

- Prepare head flashing by cutting a piece of **VersaFlange™** at least 12” **LONGER** than the head length.
- Remove the release paper from one side of the **VersaFlange™**.
- Center the flashing along the length of the PTAC unit sleeve and position so that it contacts the PTAC unit sleeve. Use firm hand pressure or a j-roller to ensure proper adhesion to the sleeve.
- Beginning at the junction of the jamb and head and away from the corners, cut the **VersaFlange™** at a 45° angle.
- Fold the newly created flashing flaps down parallel to the PTAC unit sleeve.
- Fold remaining head flashing flaps down onto the jamb.

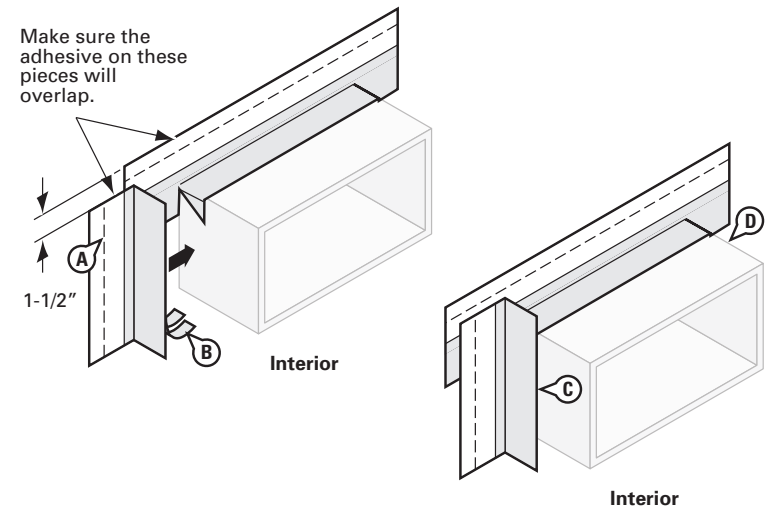

STEP 6

- Prepare jamb flashing by cutting a piece of **VersaFlange™** at least 6” **LONGER** than the jamb length.
- Remove the release paper from one side of the **VersaFlange™**.
- Position the **VersaFlange™** so that it contacts the PTAC unit sleeve up to the exterior face of the sleeve. Ensure that the jamb flashing is positioned 1-1/2 inches below top of head flashing. **Jamb flashing adhesive must come in contact with head flashing adhesive and overlap by one inch.**
- Repeat on opposite jamb.

Installation Methods for DuPont Self-Adhered Flashing Products Installed AFTER the DuPont™ Tyvek® WRB Packaged Terminal Air Conditioner (PTAC) Unit (Using DuPont™ VersaFlange™)

Option 2 – PTAC Rough Opening Less than 8” below Window Rough Opening

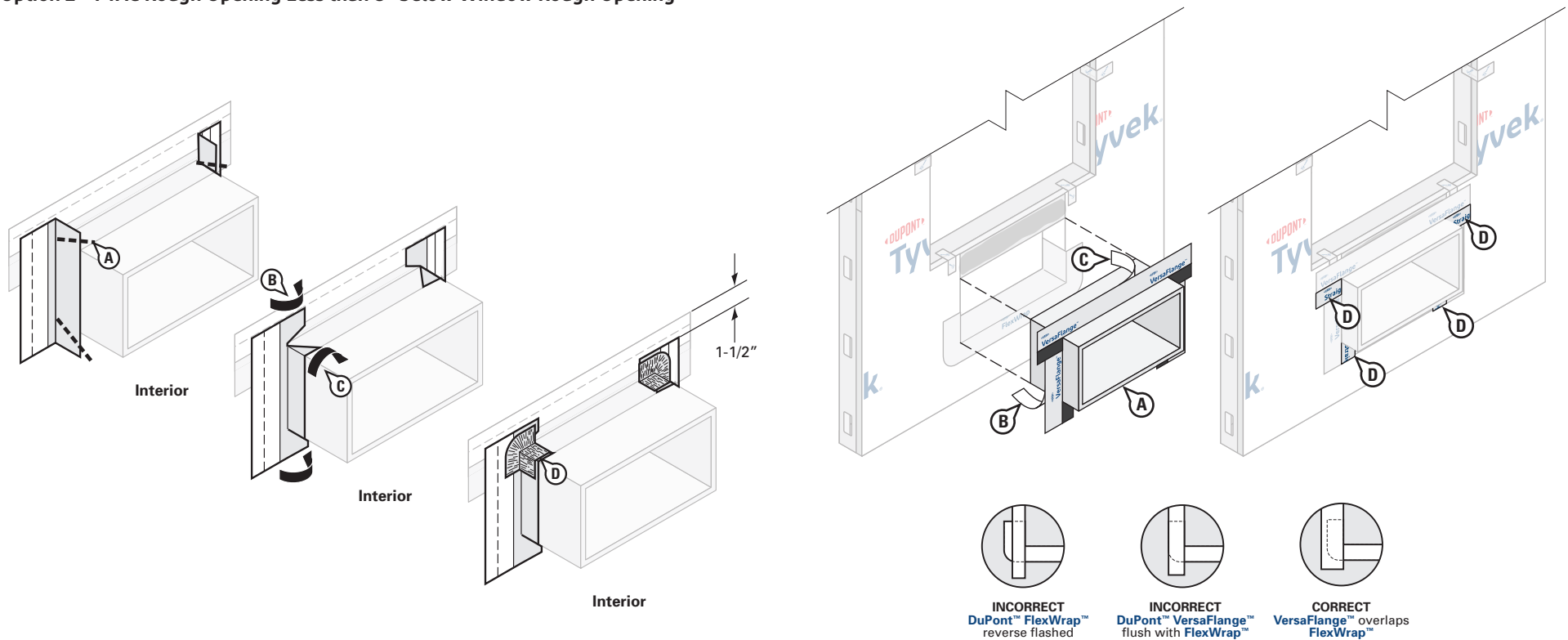

STEP 7

- Beginning at the junction of the jambs and the head, and away from the corners, cut the **DuPont™ VersaFlange™** at a 45° angle. Repeat the procedure at the junction of the sill and jambs.
- In order to overlap jamb adhesive to the head flashing adhesive, temporarily pull back release liner on the head flashing. Fold cut jamb flashing parallel to the PTAC unit sleeve so that the jamb flashing lies flat onto the head flashing. Fold the head flashing release liner back down to protect any remaining exposed butyl along the head flashing prior to installation of the PTAC unit.
- Fold remaining jamb flashing flaps down at all corners and adhere to the PTAC unit sleeve.
- Cut two 3" x 3" pieces of **DuPont™ FlexWrap™**, or two 3" pieces of **DuPont™ FlexWrap™ EZ**, and add patches to corners of the PTAC unit sleeve.

STEP 8

- Install the PTAC unit sleeve per manufacturer's instructions.
- Remove the remaining release paper from the **VersaFlange™** jamb flashing and press firmly to adhere the butyl adhesive to the **Tyvek® WRB**.
- Remove the release paper at the head and adhere the **VersaFlange™** to the wall surface.

NOTE: Head piece of **VersaFlange™**, if properly installed, will extend 4" to 4-1/2" above the PTAC rough opening. If the space between the two rough openings exceeds the width of the **VersaFlange™**, some sheathing will remain exposed below the window sill. A separate piece of flashing will be installed per the next step to cover exposed sheathing. **Do not reverse shingle. VersaFlange™ must overlap FlexWrap™ and adhere to the substrate.**

- OPTIONAL:** Cover exposed butyl and exposed sheathing with **DuPont™ StraightFlash™**, **DuPont™ Flashing Tape**, or **DuPont™ Tyvek® Tape**.

Installation Methods for DuPont Self-Adhered Flashing Products Installed **AFTER** the DuPont™ Tyvek® WRB Packaged Terminal Air Conditioner (PTAC) Unit (Using DuPont™ VersaFlange™)

Option 2 – PTAC Rough Opening Less than 8” below Window Rough Opening

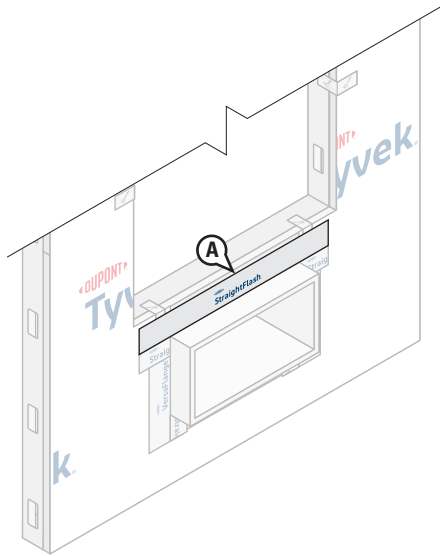

STEP 9

Only required when DuPont™ VersaFlange™ head piece does not fully cover exposed sheathing between rough openings.

- A. Cut a piece of **DuPont™ StraightFlash™** long enough to extend min. 2” **BEYOND** each end of **VersaFlange™** PTAC head flashing. Install the cut piece of flashing so top edge is flush with the window sill and is centered along the **VersaFlange™** PTAC head flashing.

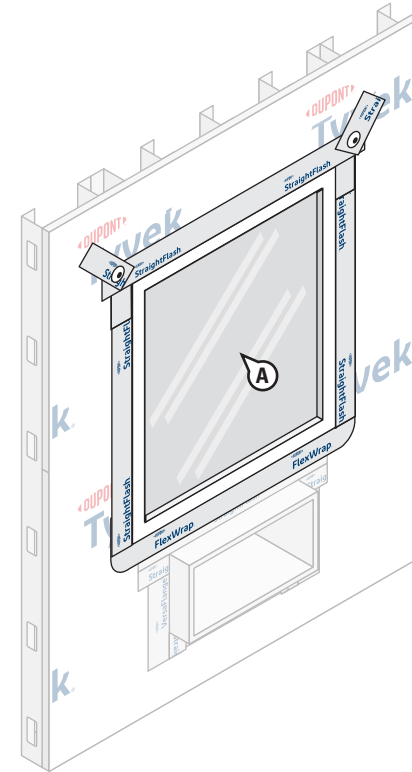

STEP 10

- A. Prepare window rough opening, install window according to manufacturer’s instructions, and flash per the [Non-Flanged Window](#) details section in this guide.

NOTE: A non-flanged window is shown. If an integral flanged window is installed above the PTAC unit, follow the applicable section within this guide.

NOTE: For a more robust install, areas with extreme wind load exposures, or high performance testing use 4” **StraightFlash™** to seal the head flap and install additional mechanical fasteners through the flashing at the head flap and perimeter of window.

Installation Methods for DuPont Self-Adhered Flashing Products Installed **AFTER** the DuPont™ Tyvek® WRB Packaged Terminal Air Conditioner (PTAC) Unit (Using DuPont™ VersaFlange™)

Option 2 – PTAC Rough Opening Less than 8” below Window Rough Opening

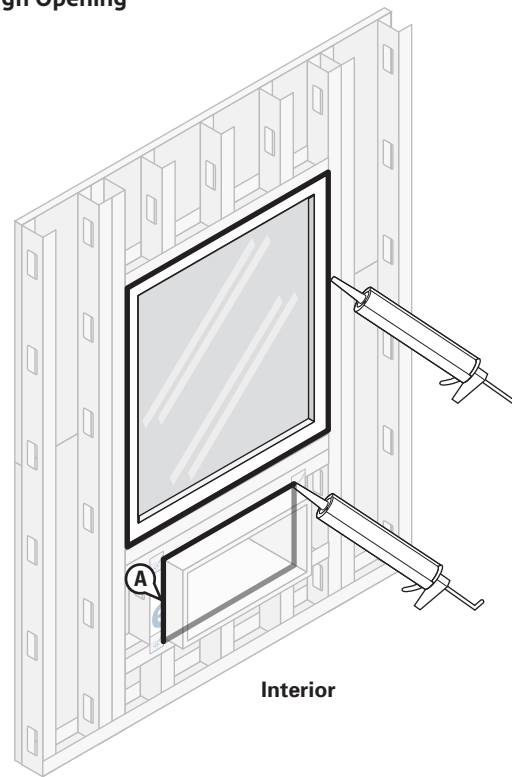

STEP 11

A. Create a continuous perimeter seal using backer rod and recommended sealant or **Great Stuff Pro™ Window and Door Polyurethane Foam Sealant** around both the window and PTAC openings at the interior to resist air and water infiltration. When using **Great Stuff Pro™ Window and Door Polyurethane Foam Sealant** in perimeter openings less than 1/2", apply using the plastic extension tip for the **Great Stuff Pro™ Dispenser Gun** during installation.

NOTE: For high performance installations exceeding ASTM E1677 wind loading pressures (10.8 psf, 65 mph equivalent structural load) and ASTM E331 water infiltration resistance of 6.24 psf, it is necessary to install sealant over the cured foam when using **Great Stuff Pro™ Window and Door Polyurethane Foam Sealant** or other recommended foam. Sealant should be installed over the foam between the window frame and rough opening around the entire interior perimeter. If **Great Stuff Pro™ Window and Door Polyurethane Foam Sealant** or other recommended foam extends **BEYOND** the window frame, shave the excess cured foam flush with the window frame before applying sealant. Avoid damaging the **DuPont Self-Adhered Flashing Product** or **Tyvek® WRB**.

Installation Methods for DuPont Self-Adhered Flashing Products and DuPont™ Tyvek® Fluid Applied Products Installed AFTER the DuPont™ Tyvek® WRB

Hybrid Condition — DuPont™ Tyvek® WRB Terminated with DuPont™ StraightFlash™ and/or DuPont™ FlexWrap™ and Integrated with DuPont™ Tyvek® Fluid Applied Products

Complex wall and window flashing conditions may require the use of **Tyvek® Fluid Applied Products** for part of a wall or window and/or door flashing. While there are many variations of this condition, it is important to properly integrate the **Tyvek® WRB** with the **Tyvek® Fluid Applied Products** using **StraightFlash™** and **FlexWrap™**. The following example shows a recessed wall plane treated with **DuPont™ Tyvek® Fluid Applied WB+™** with a window flashed with **Tyvek® Fluid Applied Products** and integrated with the **Tyvek® WRB** on the face of the wall. Refer to the [DuPont™ Tyvek® Fluid Applied Flashing Installation Guidelines](#) for more information.

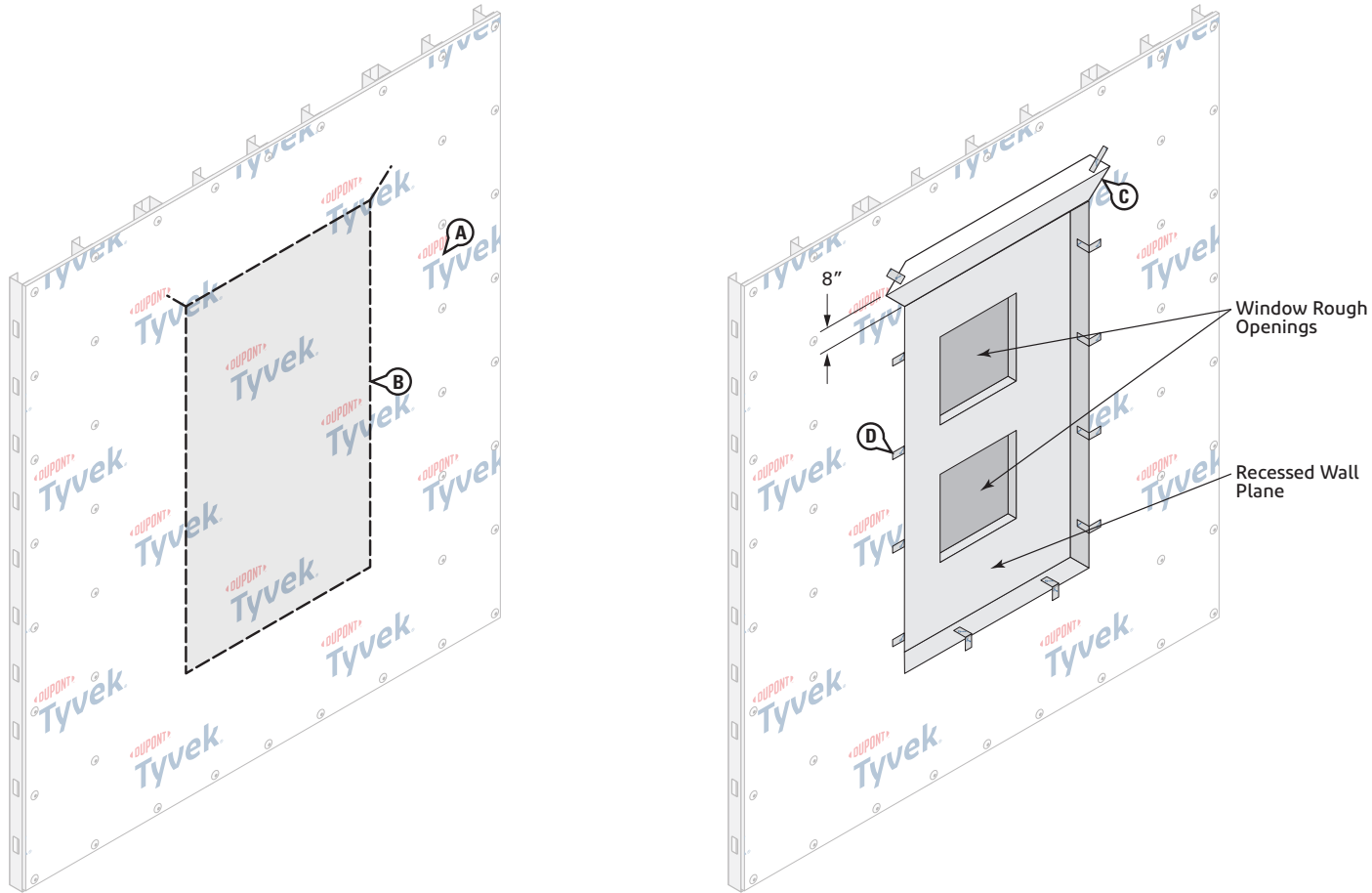

STEP 1

- Install **Tyvek® WRB** on wall per the [DuPont™ Tyvek® WRB Installation Instructions](#) section in this guide. Do not install fasteners within 6" of the bottom and sides of the openings and within 9" of the top of the recessed wall.
- Cut **Tyvek® WRB** along the perimeter of recessed wall plane.
- Cut a flap at top of recessed wall plane at a 45° angle to expose 8" of sheathing to allow for installation of transition flashing in [STEP 4](#). Flip up to expose the sheathing and temporarily secure flap with **DuPont™ Tyvek® Tape**.
- Temporarily secure **Tyvek® WRB** with **Tyvek® Tape** at perimeter of recessed wall plane to facilitate transition flashing installation.

Installation Methods for DuPont Self-Adhered Flashing Products and DuPont™ Tyvek® Fluid Applied Products Installed AFTER the DuPont™ Tyvek® WRB

Hybrid Condition — DuPont™ Tyvek® WRB Terminated with DuPont™ StraightFlash™ and/or DuPont™ FlexWrap™ and Integrated with DuPont™ Tyvek® Fluid Applied Products

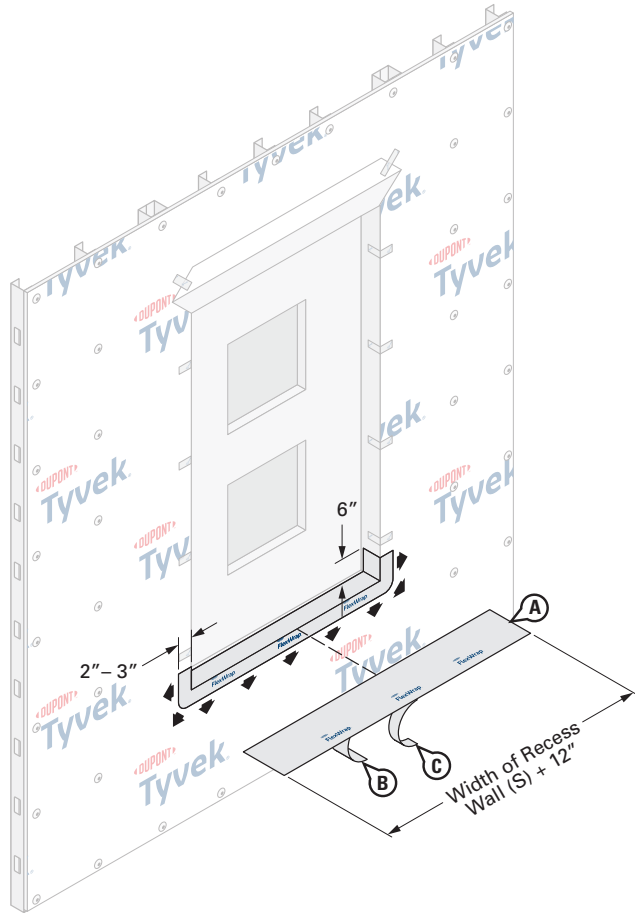

STEP 2

- Cut the **FlexWrap™** at least 12" **LONGER** than the width of recessed wall plane (W).
- Remove wide piece of release paper and adhere on horizontal ledge by aligning the inside edge of the narrow release paper with the face of the wall to ensure 2"-3" of the **FlexWrap™** will be adhered to the face of the wall with a minimum of 6" up each side.
- Remove narrow piece of release paper. Fan out the **FlexWrap™** at corners and adhere onto face of wall. Continue adhering onto face of wall along sill.*

*Use of 3-piece method is approved for conditions that are 6ft or greater in length, or the installing professional is a Commercial Certified Installer. The **StraightFlash™** is installed the width of the bottom or top of recessed wall plane prior to placing the **FlexWrap™** corners. The **FlexWrap™** corners should be at least 12" long allowing for 6" overlap onto the **StraightFlash™** at bottom, top, and sides of recessed wall plane.

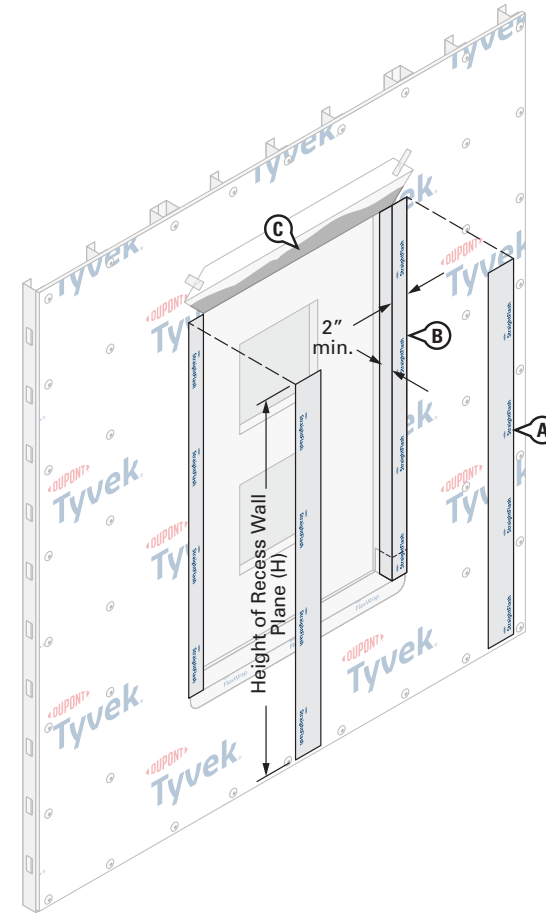

STEP 3

- Cut (2) pieces of **StraightFlash™** the height of the recessed wall plane (H) or long enough to overlap the bottom of recessed wall flashing by at least 2" and be overlapped by future top of recess wall flashing by at least 2".
- Terminate the **Tyvek® WRB** along each side of recessed wall, ensuring the **StraightFlash™** extends 2" onto the face of the wall and 2" into the recess.
- Apply a recommended adhesive/primer to the top of the recessed wall plane and exposed sheathing.

Installation Methods for DuPont Self-Adhered Flashing Products and DuPont™ Tyvek® Fluid Applied Products Installed AFTER the DuPont™ Tyvek® WRB

Hybrid Condition — DuPont™ Tyvek® WRB Terminated with DuPont™ StraightFlash™ and/or DuPont™ FlexWrap™ and Integrated with DuPont™ Tyvek® Fluid Applied Products

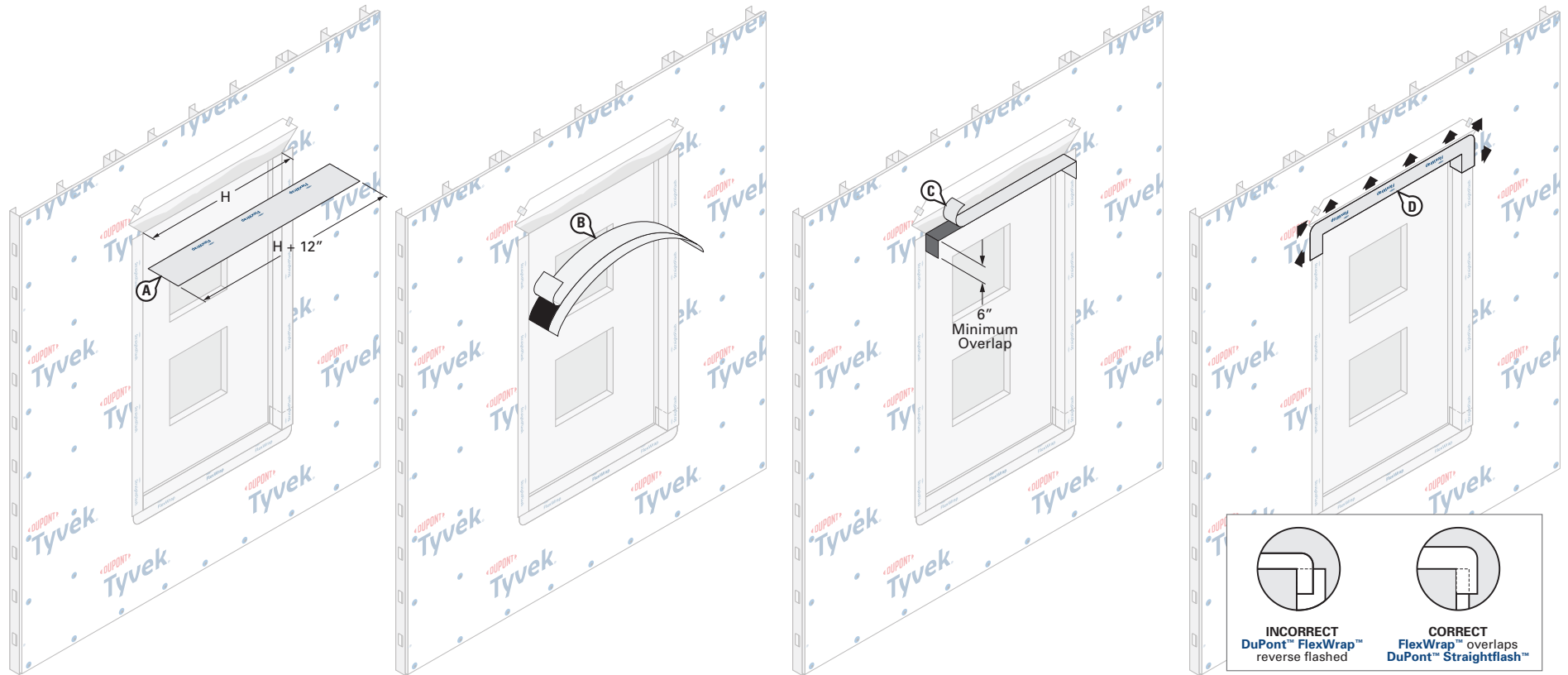

STEP 4

Install DuPont™ FlexWrap™ at Top of Recessed Wall

- Cut **FlexWrap™** at least 12" **LONGER** than width of recessed wall plane (H). Use roll widths sufficient to achieve 2"– 3" adhesion onto the face of the wall.
- Fold the **FlexWrap™** in half lengthwise to create a slight crease at the center. Remove the wide piece of release paper on one side of the fold. Align the inside edge of the narrow release paper with the face of the wall to ensure 2"– 3" of the **FlexWrap™** will be adhered to the face of the wall. Starting at the crease, adhere the **FlexWrap™** at the center of the horizontal portion of the head framing to ensure a minimum of 6" down each jamb. Adhere into rough opening at one corner and down the jamb. Remove the remaining release paper, and repeat at opposite corner.
- Remove narrow release paper.
- Fan out the **FlexWrap™** at corners and adhere onto face of wall. Continue adhering onto face of wall along the head.
- Use sufficient width of **FlexWrap™** to avoid reverse shingling of flashing at the jamb and head interface. See detail above.

*Use of 3-piece method is approved for conditions that are 6ft or greater in length, or the installing professional is a Commercial Certified Installer. The **StraightFlash™** is installed the width of the bottom or top of recessed wall plane prior to placing the **FlexWrap™** corners. The **FlexWrap™** corners should be at least 12" long allowing for 6" overlap onto the **StraightFlash™** at bottom, top, and sides of recessed wall plane.

Installation Methods for DuPont Self-Adhered Flashing Products and DuPont™ Tyvek® Fluid Applied Products Installed AFTER the DuPont™ Tyvek® WRB

Hybrid Condition — DuPont™ Tyvek® WRB Terminated with DuPont™ StraightFlash™ and/or DuPont™ FlexWrap™ and Integrated with DuPont™ Tyvek® Fluid Applied Products

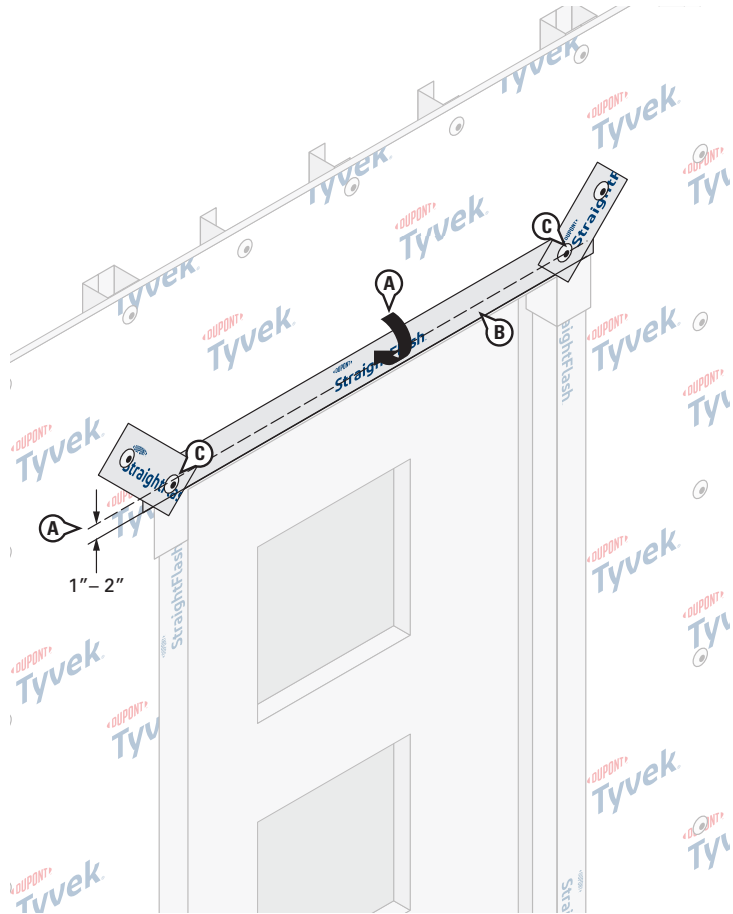

STEP 5

- Flip down **Tyvek® WRB** flap and trim 1"- 2" above top edge of recessed wall plane.
- Starting along the horizontal, terminate the head flap with 4" **DuPont™ StraightFlash™**. (See [Special Considerations](#) for allowances for using 4" **DuPont™ StraightFlash™** or 3" **Tyvek® Tape** in lieu of **StraightFlash™**).

NOTE: For a more robust install, areas with extreme wind load exposures, or high performance testing use 4" **StraightFlash™** to seal the head flap and install additional mechanical fasteners through the flashing at the head flap and perimeter of window.

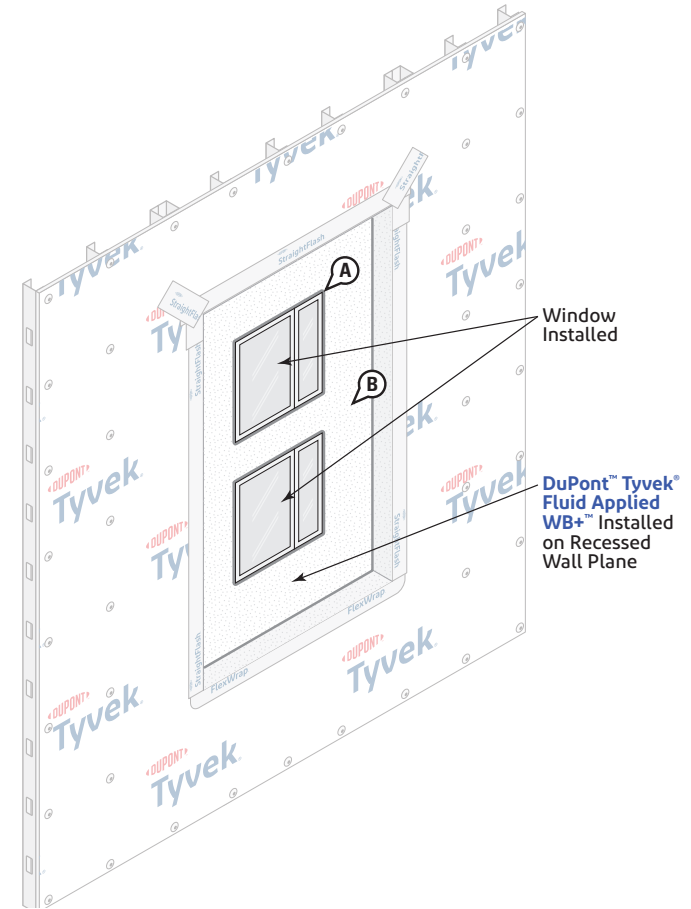

FINAL 6

Final Step

- Install **DuPont™ Tyvek® Fluid Applied Flashing and Joint Compound+** and/or **DuPont Self-Adhered Flashing Products** and window per the [DuPont™ Tyvek® Fluid Applied Flashing Installation Guidelines](#).

NOTE: Window/flashing installation sequence will vary by project and window type. All installations must allow for drainage at window sill.

- Install **DuPont™ Tyvek® Fluid Applied WB+™** per the [DuPont™ Tyvek® Fluid Applied WB+™ Wall and Substrate Guidelines](#). Overlap the **Tyvek® Fluid Applied WB+™** onto the **StraightFlash™** and **FlexWrap™** at recess wall transition by a minimum of 2".

Installation Method for Installing DuPont Self-Adhered Flashing Products BEFORE DuPont™ Tyvek® WRB Non-Flanged or Integral Flanged Window

Installation of **Tyvek® WRB** frame around window rough opening prior to window installation is necessary for proper shingling and integration with the **Tyvek® WRB** when it is installed after the window. The method shown here is installation of a non-flanged window but may be applied to all the flashing methods included in this installation guideline.

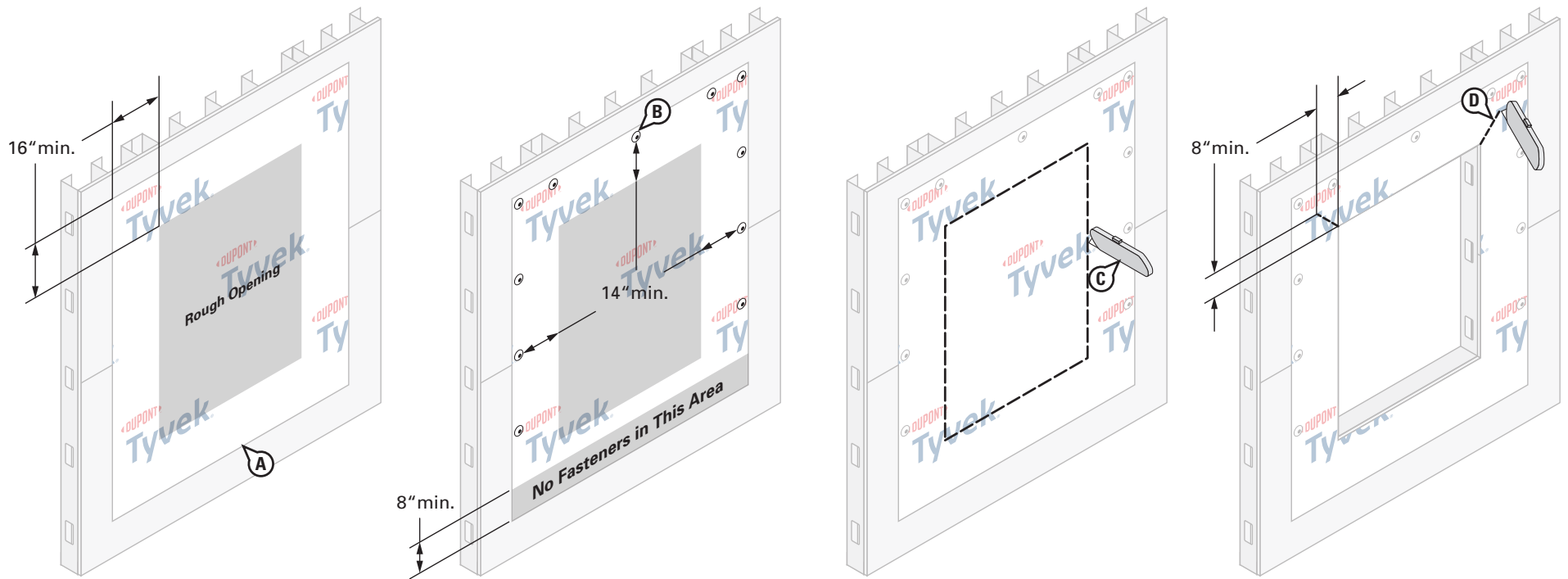

STEP 1

Install Tyvek® WRB Frame Around Window Rough Opening

- A. Cut a piece of **Tyvek® WRB** that is 32" wider and 32" taller than the window rough opening to allow a 12" width around all sides.
- B. Center the piece of **Tyvek® WRB** over the rough opening and fasten along the sides and across the top using **DuPont™ Tyvek® Wrap Caps** or recommended fasteners. Fasteners should not be installed within 14" of the edge of the rough opening, and no fasteners should be installed within 8" of the bottom edge of the **Tyvek® WRB**.
- C. Cut an opening in the **Tyvek® WRB** using a square cut around the perimeter of the rough opening to create a frame around the window (ensure that the **Tyvek® WRB** frame is cut flush ("O-cut") with the sheathing and is not wrapped into the rough opening).
- D. Cut a head flap at a 45° angle to expose 8" of sheathing to allow for head flashing installation.

NOTE: Use standard "I-Cut" per the applicable section of these installation guides when installing an integral flanged window.

Installation Method for Installing DuPont Self-Adhered Flashing Products BEFORE DuPont™ Tyvek® WRB Non-Flanged or Integral Flanged Window

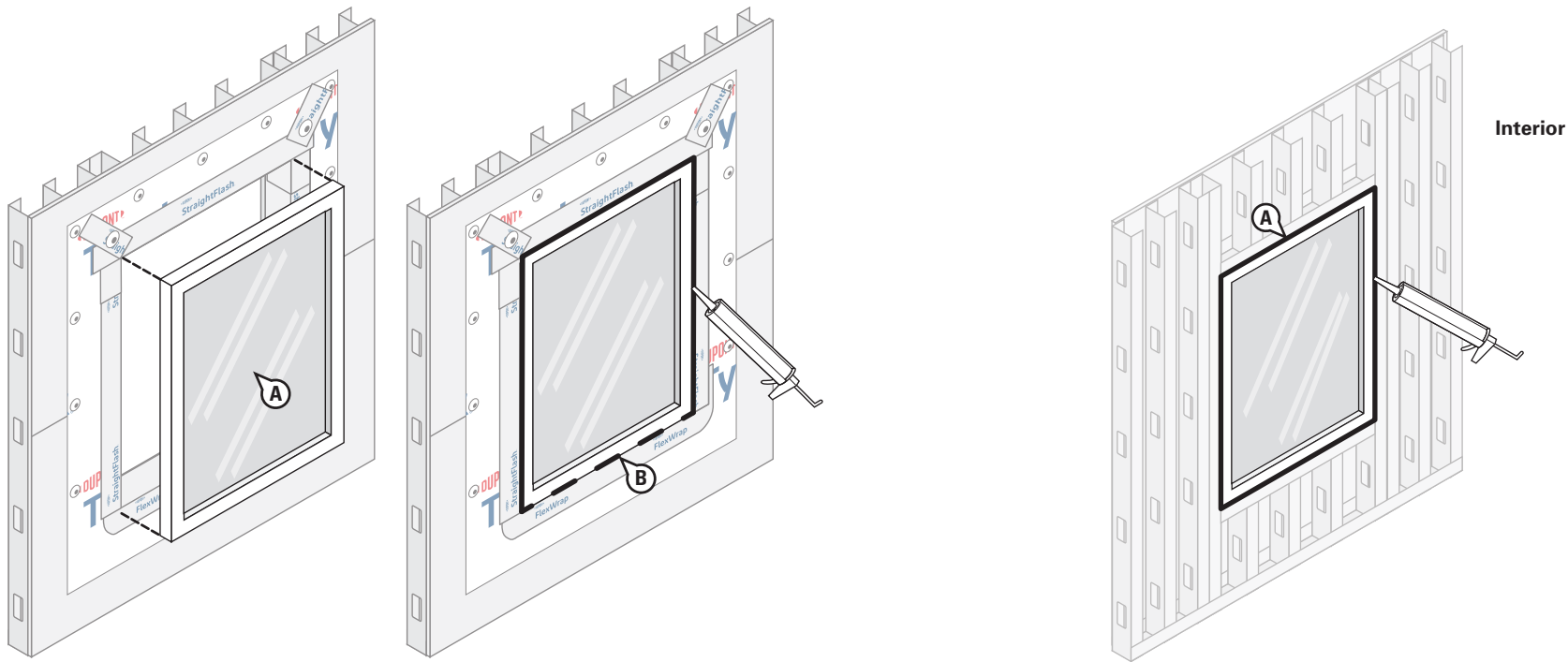

STEP 2

Install Window Per Applicable Method Based on Window Type

- Follow the applicable instructions in these install guidelines to prepare the window rough opening accordingly and install window.
- Apply an exterior perimeter seal using backer rod and recommended sealant along the jambs and head of the window opening. Refer to [Chemical Compatibility of Representative Building Sealants and Adhesives/Primers](#) for more information on recommended sealant.

NOTE: Ensure window and sealant installation allows for drainage at the sill. If sealant is applied at the sill, as a best practice, ensure that there are at least two (2) 2" gaps in the sealant bead for every 4" of window to allow for drainage.

STEP 3

- Create a continuous perimeter seal using backer rod and recommended sealant or **Great Stuff Pro™ Window and Door Polyurethane Foam Sealant** around both the window and PTAC openings at the interior to resist air and water infiltration. When using **Great Stuff Pro™ Window and Door Polyurethane Foam Sealant** in perimeter openings less than 1/2", apply using the plastic extension tip for the **Great Stuff Pro™ Dispenser Gun** during installation.

NOTE: For high performance installations exceeding ASTM E1677 wind loading pressures (10.8 psf, 65 mph equivalent structural load) and ASTM E331 water infiltration resistance of 6.24 psf, it is necessary to install sealant over the cured foam when using **Great Stuff Pro™ Window and Door Polyurethane Foam Sealant** or other recommended foam. Sealant should be installed over the foam between the window frame and rough opening around the entire interior perimeter. If **Great Stuff Pro™ Window and Door Polyurethane Foam Sealant** or other recommended foam extends **BEYOND** the window frame, shave the excess cured foam flush with the window frame before applying sealant. Avoid damaging the **DuPont Self-Adhered Flashing Product** or **Tyvek® WRB**.

Installation Method for Installing DuPont Self-Adhered Flashing Products BEFORE DuPont™ Tyvek® WRB Non-Flanged or Integral Flanged Window

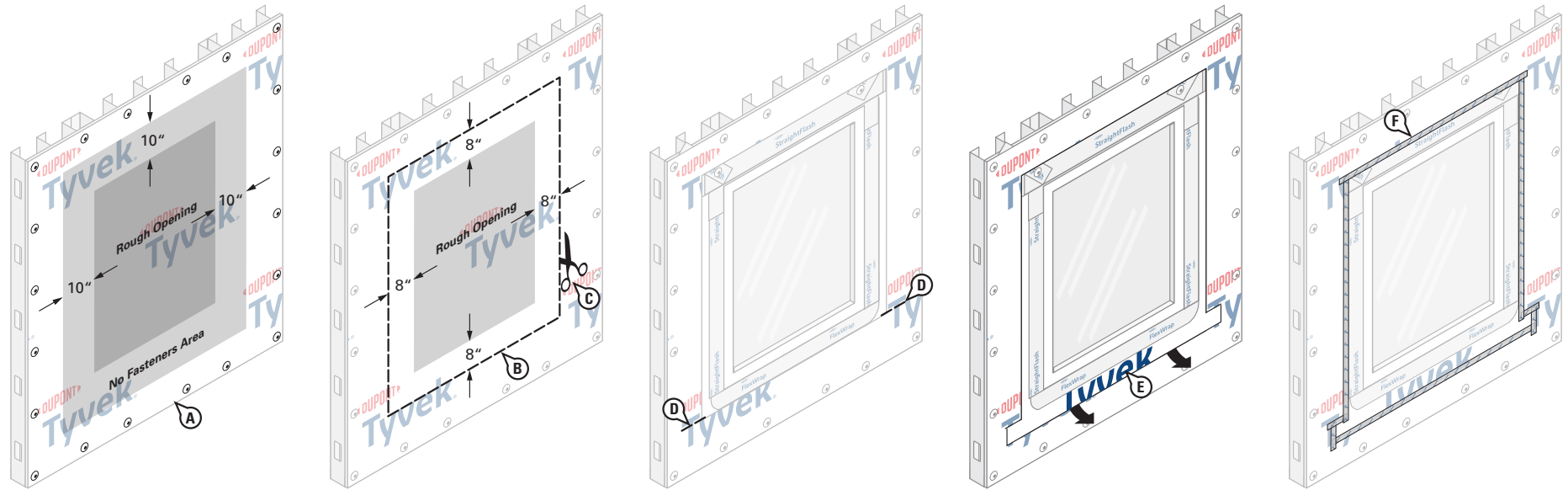

STEP 4

Install and Integrate the Tyvek® WRB

- A. Install the **Tyvek® WRB** according to the [DuPont™ Tyvek® WRB Installation Instructions](#) section in this guide. Do not install fasteners within 10" of the rough opening along jambs and head and within 12" along the sill.
 - B. Mark a perimeter box 8" away from the rough opening sill, jambs and head.
 - C. Cut the **Tyvek® WRB** along perimeter marking to expose window and **Tyvek® WRB** frame below. Do not cut **Tyvek® WRB** frame underneath.
 - D. Create 6" horizontal slits in the **Tyvek® WRB** at each lower corner of the perimeter cut.
 - E. Bring the bottom portion of the **Tyvek® WRB** frame through the slits so it laps over the top layer of **Tyvek® WRB**.
 - F. Tape seams at bottom, sides, and top of rough opening using 3" **DuPont™ Tyvek® Tape**.
- NOTE:** 3" **Tyvek® Tape** can be used to seal **Tyvek® WRB**-to-**Tyvek® WRB** seams. If the cut edges of the **Tyvek® WRB** are positioned over the window flashing, the **Tyvek® WRB** must be terminated around the perimeter of the window (jambs and head) with another layer of **DuPont™ StraightFlash™**.

Facade/Exterior Considerations

Brick

The Brick Industry Association recommends a 1" air space in front of wood stud construction and a 2" air space in front of steel stud construction. Consistent with these requirements and recommendations, **DuPont™ Tyvek® WRBs** shall be separated from the brick veneer by a minimum 1" air space. Window and door flashing, and through wall flashing shall be integrated with the **Tyvek® WRB** layer ensuring proper shingling. For maximum moisture management and drying of the wall system the air space in front of the **Tyvek® WRB** shall be vented to the exterior at the top and bottom of the wall. Some types of brick ties can act as alternate fasteners for **Tyvek® WRBs** and may reduce the required number of fasteners if installed as soon as practically possible. **DuPont Self-Adhered Flashing Products** or recommended alternate patch is required for high performance installations.

EIFS

Tyvek® WRBs and EIFS cladding shall be installed according to manufacturer's instructions and industry standards. In order to promote drainage, it is recommended that **DuPont™ Tyvek® CommercialWrap® D** be installed behind the exterior insulation. Window and door flashing, and through wall flashing shall be integrated with the **Tyvek® WRB** layer ensuring proper shingling. The successful installation and performance of EIFS cladding is dependent upon the proper design and construction of the adjacent materials and systems of the structure.

Tyvek® CommercialWrap® provides >90% drainage efficiency, and **Tyvek® CommercialWrap® D** provides >98% drainage efficiency when tested in accordance with ASTM E2273.

Exterior Insulation

When using **Tyvek® WRBs** with **DuPont Exterior Continuous Insulation Products**, please refer the applicable Commercial Wall? Installation Bulletin for guidance on fasteners and product installation. **Tyvek® WRBs** and exterior continuous insulation shall be installed according to the manufacturer's instructions and industry standards. **Tyvek® WRBs** can be installed either over the exterior continuous insulation or underneath between the sheathing and the exterior insulation. In order to promote drainage, it is recommended that **Tyvek® CommercialWrap® D** be used when installing the **Tyvek® WRB** between the sheathing and the exterior continuous insulation. Window flashing, door flashing, and through wall flashing shall be integrated with the **Tyvek® WRB** layer ensuring proper shingling. The successful installation and performance of exterior continuous insulation is dependent upon the proper design and construction of adjacent materials and systems of the structure.

Stucco

When stucco is installed over wood-based sheathing, the 2018 International Building Code (Section 2510.6) requires a water-resistive vapor-permeable barrier with performance at least equivalent to two layers of water resistive barrier complying with ASTM E 2556, Type I, or a water resistive barrier which is separated from the stucco by an intervening, substantially non water-absorbing layer or drainage space. "The individual layers shall be installed independently such that each layer provides a separate continuous plane and any flashing intended to drain to the water-resistive barrier is directed between the layers." **Tyvek® WRBs** used behind stucco should be separated from the stucco by a second layer of **Tyvek® WRB**, a layer of Grade D building paper, felt, exterior continuous foam insulation or the paper backing of paper-backed lath. The first layer (directly over sheathing or studs) serves as the wall system's air and water barrier and is integrated with window and door flashings, the weep screed at the bottom of the wall and any through wall flashing or expansion joints. Lath shall be installed over the intervening layer (second layer) in accordance with ASTM C1063-03 *Standard Specification for Installation of Lathing and Furring to Receive Interior and Exterior Portland Cement-Based Plaster* and applicable codes. When exterior continuous foam insulation is installed over **Tyvek® WRB** as an intervening layer, may provide enhanced structural support to the **Tyvek® WRB** layer and may reduce the required number of fasteners used for the attachment of the **Tyvek® WRB** if installed as soon as practically possible. **DuPont Self-Adhered Flashing Products** or recommended alternate may be required for high performance installations.

Tyvek® CommercialWrap® provides >90% drainage efficiency, and **Tyvek® CommercialWrap® D** provides >98% drainage efficiency when tested in accordance with ASTM E2273.

Metal Panel

Tyvek® WRBs and metal panel cladding systems shall be installed according to manufacturer's instructions and industry standards. **DuPont™ StraightFlash™**, **DuPont™ Flashing Tape**, or recommended alternate patch must be installed behind all metal installation brackets and hat-channels fasteners. **NOTE:** The maximum in-service temperature for **Tyvek® WRBs**, **DuPont Self-Adhered Flashing Products**, and **DuPont™ Tyvek® Fluid Applied Products** is 180°F.

Stone Veneer

The 2018 International Building Code (Section 1404.7) requires two layers of air and water barrier behind stone veneers over wood frame construction. When used behind stone veneer, **Tyvek® WRBs** shall be installed in a similar manner as they are installed behind stucco. The **Tyvek® WRB** should be separated from the stone and mortar by a second layer of **Tyvek® WRB**, a layer of grade D building paper, felt, exterior continuous foam insulation or the paper backing of paper-backed lath. The first layer (directly over sheathing or studs) serves as the wall system's air and water barrier and shall be integrated with window and door flashings, the weep screed at the bottom of the wall and any through wall flashing or expansion joints. Lath shall be installed over the intervening layer (second layer) in accordance with ASTM C1063-03 Standard Specification for Installation of Lathing and Furring to Receive Interior and Exterior Portland Cement-Based Plaster and applicable codes. When exterior continuous foam insulation is used as the second layer, it is installed over the **Tyvek® WRB**. **Tyvek® CommercialWrap® D** is recommended for this application. **DuPont Self-Adhered Flashing Products** or recommended alternate patch is required for high performance installations.

Tyvek® CommercialWrap® provides >90% drainage efficiency, and **Tyvek® CommercialWrap® D** provides >98% drainage efficiency when tested in accordance with ASTM E2273.

Wood Siding

DuPont™ Tyvek® WRBs and wood siding shall be installed according to manufacturer's instructions, industry standards and applicable codes. As recommended by the Western Red Cedar Lumber Association and U. S. Forest Product Laboratory, wood siding should be primed on all six sides before installation. When installed over exterior continuous insulation, the Western Red Cedar Lumber Association and other wood siding manufacturers recommend that furring strips are used to create an air space between the exterior continuous insulation and siding. Other recommendations that should be followed to minimize potential problems are:

- Use thicker siding patterns in widths of 8 inches or less. Thick, narrow siding is more stable than thinner, wider patterns and better able to resist dimensional changes.
- Use kiln-dried siding over exterior continuous insulation.
- Proper pre-finishing is essential.
- Use light color finish coats to maximize heat reflection and reduce dimensional movement.
- **DuPont™ Tyvek® CommercialWrap®** applied over the exterior continuous insulation is recommended for this application.

In high exposure installations, enhanced drainage and water management may be provided by using **DuPont™ Tyvek® CommercialWrap® D**, by installing a drainage mesh over the **Tyvek® WRB**, or by creating a rain screen cladding with a larger air space behind the siding using furring strips. **Tyvek® CommercialWrap®** provides >90% drainage efficiency, and **Tyvek® CommercialWrap® D** provides >98% drainage efficiency when tested in accordance with ASTM E2273.

Fiber Cement Siding

Tyvek® WRBs and fiber cement siding shall be installed according to manufacturer's instructions and industry standards. In high exposure installations, enhanced drainage and water management may be provided by using **Tyvek® CommercialWrap® D**, by installing a drainage mesh over the water-resistive barrier, or by creating rain screen cladding with a larger air space behind the siding using furring strips. **Tyvek® WRBs** and fiber cement siding shall be installed according to manufacturer's instructions, industry standards and applicable codes. **Tyvek® CommercialWrap® D** offers > 98% drainage efficiency when tested in accordance with ASTM E2273. See *Alternate Fastening* section, for additional information.

Product Composition and UV Stability

DuPont™ Tyvek® WRBs used in construction products are made from 100% flash spunbonded high density polyethylene fibers which have been bonded together by heat and pressure, without binders or fillers, into a tough durable sheet structure. Additives have been incorporated into the polyethylene to provide ultraviolet light resistance. DuPont requires that **DuPont™**

Tyvek® CommercialWrap® and **Tyvek® CommercialWrap® D** be covered within 9 months (270 days) of installation.

DuPont Self-Adhered Flashing Products are made from a synthetic rubber adhesive and a top sheet of flash spunbonded high density polyethylene fibers or polypropylene film. Additives have been incorporated into these materials to provide ultraviolet light resistance. DuPont requires that **DuPont™ FlexWrap™**, **DuPont™ FlexWrap™ EZ**, and **DuPont™ StraightFlash™** be covered within nine months (270 days) of installation.

DuPont™ Tyvek® Fluid Applied Products are silyl-terminated polyether based. They are formulated to include elastomeric polymers that cure to a continuous, fully-adhered, tough, durable membrane. Additives have been incorporated to provide ultraviolet light resistance. DuPont requires that the **DuPont™ Tyvek® Fluid Applied WB+™** and **DuPont™ Tyvek® Fluid Applied Flashing and Joint Compound+™** are to be covered within 9 months (270 days) of installation.

Design Considerations

DuPont Building Envelope Solutions Products are to be used as outlined in this installation guideline. **DuPont Self-Adhered Flashing Products** and **Tyvek® Fluid Applied Flashing and Joint Compound+™** should only be used to seal penetrations and flash openings in buildings. **Tyvek® WRBs**, **Tyvek® Fluid Applied Products**, and **DuPont Self-Adhered Flashing Products** are not to be used in roofing applications.

When installed in conjunction with other building materials, **Tyvek® WRBs**, **DuPont Self-Adhered Flashing Products**, and **Tyvek® Fluid Applied Products** must be properly shingled with these materials such that water is diverted to the exterior of the wall system. **Tyvek® WRBs** and **Tyvek® Fluid Applied WB+™** are secondary weather barriers. The outer facade is the primary barrier.

Follow facade manufacturer's installation and maintenance requirements for all facade systems in order to maintain water holdout properties and ensure performance of **Tyvek® WRBs** and **Tyvek® Fluid Applied WB+™**.

Do not install on a wall that does not feature a continuous path for moisture drainage. Any standing water must be allowed to drain off the membrane.

Use of additives, coatings or cleansers on or in the facade system may impact the performance of **Tyvek® WRBs** and **Tyvek® Fluid Applied WB+™**.

For superior protection against bulk water penetration, DuPont suggests a system combining a quality exterior facade, a good secondary air and water barrier and exterior sheathing, high quality windows and doors, and appropriate flashing

materials paying attention to proper installation of each component.

In a system where no exterior sheathing is used and **Tyvek® WRBs** are installed directly over the wall studs, exterior facade materials should be selected to ensure maximum protection against water intrusion. Careful workmanship and proper installation of each component is very important.

Depending on job site conditions, stains may appear on the **Tyvek® Fluid Applied Products**, these discolorations will not alter the products' performance.

Safety and Handling

Warning

Tyvek® WRBs are slippery and should not be used in any application where they will be walked on. In addition, because they are slippery, DuPont recommends using kickjacks, scaffolding, or lifts for exterior work above the first floor. If ladders must be used, extra caution must be taken to use them safely by following the requirements set forth in ANSI Standards 14.1, 14.2, and 14.5 for ladders made of wood, aluminum, and fiberglass, respectively. **DuPont™ Tyvek®** is combustible and should be protected from flames and other high heat sources. **DuPont™ Tyvek®** will melt at 275°F (135°C) and if the temperature of **DuPont™ Tyvek®** reaches 750°F (400°C), it will burn and the fire may spread and fall away from the point of ignition. For more information, call 1-833-338-7668.

DuPont Self-Adhered Flashing Products and their release paper are slippery and should not be walked on. Remove release paper from work area immediately. **DuPont Self-Adhered Flashing Products** will melt at temperatures greater than

250°F (121°C). **DuPont Self-Adhered Flashing Products** are combustible and should be protected from flames and other high heat sources. **DuPont Self-Adhered Flashing Products** will not support combustion if the heat source is removed. However, if burning occurs, ignited droplets may fall away from the point of ignition. For more information, call 1-833-338-7668.

Tyvek® Fluid Applied Products may cause irritation. Repeated or prolonged skin contact may cause allergic reactions with susceptible persons. May cause irritation of respiratory tract. **Tyvek® Fluid Applied Products** are mixtures. Safety and Handling information is based on the products' components. Refer to each product's Safety Data Sheet (SDS) for further information.

KEEP OUT OF REACH OF CHILDREN.

Children can fall in to bucket and drown. Keep children away from bucket with even a small amount of liquid.

Use only as directed. Avoid inhalation of vapor aerosol.

Caution

Tyvek® Fluid Applied Products are **FOR PROFESSIONAL USE ONLY**. Do not handle until all safety precautions have been read and understood. Avoid breathing dust/fumes/gas/mist/vapors/spray. Vapor and aerosols are harmful when using a spray application. If airborne particles are inhaled while spraying, immediately, immediately move from exposure to fresh air and contact a physician. Use in a well-ventilated area. A NIOSH-approved particulate filtering full-face respirator with a P95 particulate filter or half-mask respirator with a P95 particulate filter and splash impact goggles must be

used when spraying. NIOSH-approved N95 disposable safety mask with splash impact goggles can be used for manual application such as troweling or rolling, and for clean-up. If vapors are inhaled, immediately move from exposure to fresh air and contact a physician.

Contaminated work clothing should not be allowed out of the workplace. Wear protective gloves/protective clothing/eye protection/face protection. IF ON SKIN: Wash with plenty of soap and water. IF IN EYES: Rinse cautiously with water for several minutes. Remove contact lenses, if present and easy to do. Continue rinsing. IF EXPOSED OR CONCERNED: Get medical advice/attention. Immediately call a POISON CENTER/doctor. IF SKIN IRRITATION OR RASH OCCURS: Get medical advice/ attention. Wash contaminated clothing before reuse. Store locked up. Dispose of contents/ container to an approved waste disposal plant. Avoid contact with eyes and skin.

When cured, **Great Stuff Pro™ Window & Door Polyurethane Foam Sealant** is combustible and will burn if exposed to open flame or sparks from high-energy sources. Do not expose to temperatures above 240°F (116°C). For more information, consult (Material) Safety Data Sheet ((M)SDS), call DuPont at 1-866-583-2583. When air sealing buildings, ensure that combustion appliances, such as furnaces, water heaters, wood burning stoves, gas stoves and gas dryers are properly vented to the outside. See website: <https://www.nrel.gov/docs/fy14osti/61326.pdf>.

In Canada visit: <https://nrc-publications.canada.ca/eng/view/ft/?id=96acba7c-afd4-4ea1-94b0-1f8f3500c582>.

Great Stuff Pro™ polyurethane foam sealant and adhesive products contain isocyanate and a flammable blowing agent. Read all instructions and (Material) Safety Data Sheet ((M)SDS), carefully before use. Eliminate all sources of ignition before use. Cover all skin. Wear long sleeves, gloves, and safety glasses or goggles. Not for use in aviation, or food/ beverage contact, or as structural support in marine applications. Provide adequate ventilation or wear proper respiratory protection. Contents under pressure. Not to be used for filling closed cavities or voids such as behind walls and under tub surrounds; this improper use of the product could result in the accumulation of flammable vapors and/or uncured material. Failure to follow the warnings and instructions provided with the product, and/or all applicable rules and regulations, can result in injury or death.

Building and/or construction practices unrelated to building materials could greatly affect moisture and the potential for mold formation. No material supplied by DuPont can give assurance that mold will not develop in any specific system.

Read all instructions and (Material) Safety Data Sheet ((M)SDS) carefully before use.

For more information, visit greatstuffpro.com or building.dupont.com

Hazard Statement

Tyvek® Fluid Applied Products may cause an allergic skin reaction. May cause serious eye damage. May cause genetic defects. May damage fertility or the unborn child. As it relates to California Prop 65, **Tyvek® Fluid Applied Products** can expose you to substances including Crystalline silica, which is /are known to the State of California to cause cancer. For more information, visit p65Warnings.ca.gov.

For complete warranty information please call 1-833-338-7668 or visit us at building.dupont.com.

For More Information

Visit the *Quick Links* section of our website (<https://www.dupont.com/building/resources.html>) where you'll find links to essential documents and resources to help you get the job done right:

- Installation Guidelines
- Safety Data Sheets (SDS)
- CAD Drawings
- DuPont Performance Building
- Solutions Document Library

For complete warranty information please call 1-833-338-7668 or visit us at building.dupont.com.

NOTICE: No freedom from any patent owned by DuPont or others is to be inferred. Because use conditions and applicable laws may differ from one location to another and may change with time, Customer is responsible for determining whether products and the information in this document are appropriate for Customer's use and for ensuring that Customer's workplace and disposal practices are in compliance with applicable laws and other government enactments. The product shown in this literature may not be available for sale and/or available in all geographies where DuPont is represented. The claims made may not have been approved for use in all countries or regions. DuPont assumes no obligation or liability for the information in this document. References to "DuPont" or the "Company" mean the DuPont legal entity selling the products to Customer unless otherwise expressly noted. NO EXPRESS WARRANTIES ARE GIVEN EXCEPT FOR ANY APPLICABLE WRITTEN WARRANTIES SPECIFICALLY PROVIDED BY DUPONT. ALL IMPLIED WARRANTIES INCLUDING THOSE OF MERCHANTABILITY AND FITNESS FOR A PARTICULAR PURPOSE ARE EXPRESSLY EXCLUDED. The buyer assumes all risks as to the use of the material. Buyer's exclusive remedy or any claim (including without limitations, negligence, strict liability, or tort) shall be limited to the refund of the purchase price of the material. Failure to strictly adhere to any recommended procedures shall release DuPont de Nemours, Inc., and its affiliates, of all liability with respect to the materials or the use thereof. The information herein is not intended for use by non-professional designers, applicators or other persons who do not purchase or utilize this product in the normal course of their business.

© 2022 DuPont. DuPont™, the DuPont Oval Logo, and all trademarks and service marks denoted with ™, SM or ® are owned by affiliates of DuPont de Nemours, Inc. unless otherwise noted. Grip-Deck®, Grip-Lok®, Thermal-Grip®, and Thermal-Grip FastCap™ are trademarks or registered trademarks of TRUFAST® Walls (formerly Rodenhouse Inc.). 2-Seal™ is a trademark of Hohmann & Barnard, Inc. Heckmann™ and Posi-Tie® are trademarks or registered trademarks of Mechanical Plastics Corp.

43-D101090-enUS-0722



For more information about
DuPont Performance Building Solutions,
please call 1-833-338-7668 or visit us at
building.dupont.com