

# Perimeter Seal and Parapet/Roof Repair Using Froth-Pak™ Foam Sealant Kit

## Installation Recommendations

---

### Description

DuPont™ Froth-Pak™ Foam Sealant is a portable, two-component, spray polyurethane foam dispensing system for air sealing, insulation and moisture management around the building envelope. Reducing air leakage is crucial for enhancing building envelope performance. Often a source of air leakage is around the perimeter of the building between the roof deck and parapet. Sealing this area during construction can potentially reduce costly repairs later, as well as improve building performance.

Froth-Pak™ Foam Sealant also can be a cost-effective way to repair the parapet/roof deck area.

### Getting Ready

#### Estimate Application Area

Before selecting a Froth-Pak™ Foam Sealant kit, determine the amount of foam needed to complete the task. For example, the Froth-Pak™ 200 kit has a theoretical yield of 200 board feet (0.46 m<sup>3</sup>) of foam.

### Materials and Equipment

Froth-Pak™ Foam Sealant kit complete with gun/hose assembly, dispensing nozzles, petroleum jelly packet and operating instructions

- Protective clothing (including long sleeves), goggles or safety glasses, gloves and respiratory protection
- Roofing knife or handsaw
- 10-12 mil polyethylene
- 5/8" to 3/4" (16 mm to 19 mm) plywood if repairing (larger than area to be repaired)
- Paintbrush or roller
- Protective roof coating (similar or compatible to originally applied coating).

### Safety and Conditions of Use

- Read the instructions and (Material) Safety Data Sheets ((M)SDS) carefully before use.
- Froth-Pak™ spray polyurethane foam contains isocyanate, hydrofluorocarbon blowing agent and polyol. Do not breathe vapor or mist. Use only in well-ventilated areas or with proper respiratory protection.
- Supplied air or an approved air-purifying respirator equipped with an organic vapor Perimeter Seal and Parapet/Roof Repair Using Froth-Pak™ Foam Sealant Kit sorbent and a P100 particulate filter may be required to maintain exposure levels below ACGIH, OSHA, WEEL or other applicable limits. For situations where the atmospheric levels may exceed the level for which an air-purifying respirator is effective, use a positive-pressure, air-supplying respirator (air line or self-contained breathing apparatus).
- Isocyanate is irritating to the eyes, skin and respiratory system, and may cause sensitization by inhalation or skin contact.
- Froth-Pak™ Foam will adhere to most surfaces and skin. Do not get foam on skin. Wear protective clothing and cover all skin (including long sleeves), gloves, goggles or safety glasses, and protective clothing. Cured foam must be mechanically removed or allowed to wear off in time.
- The contents are under pressure.
- Froth-Pak™ Foam should not be used around heaters, furnaces, fireplaces, recessed lighting fixtures or other applications where the foam may come in contact with heat-conducting surfaces. Cured Froth-Pak™ Foam is combustible and will burn if exposed to open flame or sparks from high-energy sources. Do not expose to temperatures above 240°F (116°C).
- Ensure the downwind area is secure and void of people without PPE and does not contain items that may be damaged by spray, such as cars.

## Application

DuPont™ Froth-Pak™ Foam Sealant should be applied when the ambient temperature is from 60°F to 90°F (16°C to 32°C). For best results, the tank contents should be at 75°F to 85°F (24°C to 29°C). Froth-Pak™ Foam Sealant can be applied effectively in cold air temperatures or on cool work surfaces (above freezing) provided the kit contents are at 75°F to 85°F (24°C to 29°C).

1. Remove all contaminants (water, oil, dust, dirt, debris, old sealants, etc.) that could affect the adhesion between the roof deck, parapet and foam. If in doubt, conduct an adhesion test, waiting at least 1 hour to assess the bond.
2. Check material compatibility. Froth-Pak™ Foam Sealant is not compatible with silicone coatings. Remove any silicone coating at least 6" (15 cm) from the area to be sprayed.

**Note:** Always check with local building officials and codes for additional requirements prior to using Froth-Pak™ Foam Sealant.

3. Follow the operating instructions included in the Froth-Pak™ Foam Sealant kit packaging. Contact your local DuPont representative or visit [www.building.solutions.com](http://www.building.solutions.com) for more information.

## Seal Perimeter (during construction)

Froth-Pak™ Foam Sealant can be easily installed around the perimeter on the exterior side of the roofing assembly. Install the foam prior to installing the membrane or insulation.

Froth-Pak™ Foam Sealant meets the requirements for use on the exterior of a commercial roof per Section 2603 of the International Building Code. The code requires that foam plastic insulations have surface burning characteristics of  $\leq 25$  flame spread index and  $\leq 450$  smoke developed index. The application of the product is limited to an area of 4" (10 cm) wide x 2" (5 cm) thick for an unlimited length.

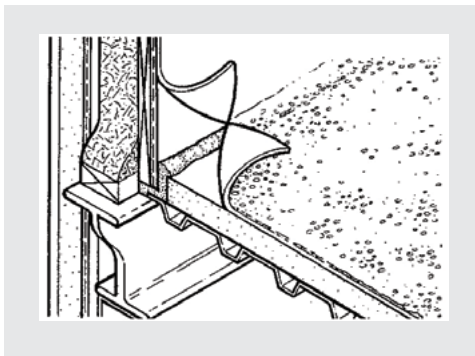

Figure 1

**Note:** During application, the foam exerts force as it expands. Monitor the amount of foam installed to avoid overfilling restricted spaces.

1. Apply foam 2" (5 cm) thick or less between the roof deck and parapet (Figure 1).
2. In approximately 5 minutes, remove any overspray with a roofing knife. If additional shaping is required, cut the cured foam with a handsaw.

## General Applications

### Fill small pitch pockets:

1. Depending on the depth of the pocket, use two or more coats or passes of the foam to obtain the desired thickness (Figure 2). Apply the foam in layers of 2" (5 cm) or less in any single pass.

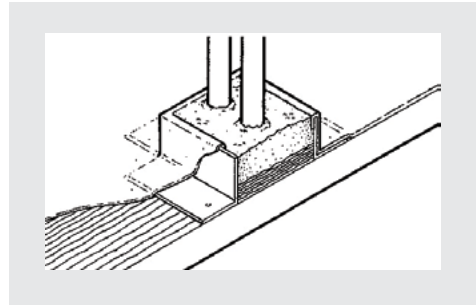

Figure 2

**Note:** If the foaming area to be filled is wide, start by spraying from the edge and build toward the center.

2. In approximately 5 minutes, the foam should be no higher than the top of the pocket.

### Repair Parapet/Roof:

1. If the area to be repaired has been previously painted, scrape away all loose or poorly adhered paint. Conduct an adhesion test if any previously painted surfaces are involved in the repair.

If the area is wet, let the surface dry completely. Any additional moisture may cause premature curing and limit work time of the Froth-Pak™ Foam Sealant.

2. Check the underlying substrate for soundness and repair, if applicable.

- Cut the damaged or blistered area at an inward, tapered, 45° angle (Figure 3). Cut back any defective and moist foam until solid, dry foam is exposed. Where possible, remove at least 6" (15 cm) beyond the area to be repaired.

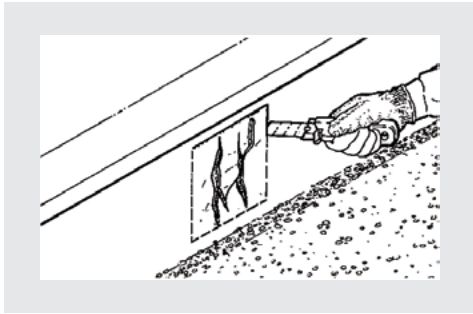

Figure 3

- Place a piece of plywood wrapped in polyethylene next to the area to be filled.
- Depending on the depth of the repair area, use two or more coats/ passes of DuPont™ Froth-Pak™ Foam Sealant to obtain a thickness that is approximately 2" (5 cm) from the top of the area. Apply the foam in layers of 2" or less in any single pass (Figure 4).

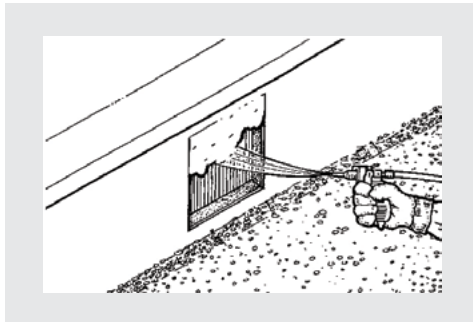

Figure 4

- To "form" the final pass, place the plywood wrapped in polyethylene over the area to be filled. Carefully spray the foam under the plywood, holding the plywood down (Figure 5). Wait about a minute for the foam to rise to the underside of the plywood and begin curing. Remove the plywood, checking that the foam is equal to the height of the surrounding parapet.
- In approximately 5 minutes, remove any overspray with a roofing knife (Figure 6). If additional shaping is required, cut the cured foam with a handsaw.



Figure 5



Figure 6

### Apply Finish Coating (if required)

Brush or roll a 30-40 mil quality protective coating (similar to the originally applied coating) within 3 hours after application.

### Disposal

- Dispose of any foam waste and empty Froth-Pak™ Foam Sealant cylinders as a non-hazardous waste (outlined in the operating instructions) and in accordance with local and state regulations.
- Depressurize cylinders prior to disposal.



**For more information visit  
building.dupont.com  
or call 1-866-583-2583**

**NOTICE:** No freedom from any patent owned by DuPont or others is to be inferred. Because use conditions and applicable laws may differ from one location to another and may change with time, Customer is responsible for determining whether products and the information in this document are appropriate for Customer's use and for ensuring that Customer's workplace and disposal practices are in compliance with applicable laws and other government enactments. The product shown in this literature may not be available for sale and/or available in all geographies where DuPont is represented. The claims made may not have been approved for use in all countries or regions. DuPont assumes no obligation or liability for the information in this document. References to "DuPont" or the "Company" mean the DuPont legal entity selling the products to Customer unless otherwise expressly noted. **NO EXPRESS WARRANTIES ARE GIVEN EXCEPT FOR ANY APPLICABLE WRITTEN WARRANTIES SPECIFICALLY PROVIDED BY DUPONT. ALL IMPLIED WARRANTIES INCLUDING THOSE OF MERCHANTABILITY AND FITNESS FOR A PARTICULAR PURPOSE ARE EXPRESSLY EXCLUDED.** The buyer assumes all risks as to the use of the material. Buyer's exclusive remedy or any claim (including without limitations, negligence, strict liability, or tort) shall be limited to the refund of the purchase price of the material. Failure to strictly adhere to any recommended procedures shall release DuPont Specialty Products USA, LLC or its affiliates, of all liability with respect to the materials or the use thereof. The information herein is not intended for use by non-professional designers, applicators or other persons who do not purchase or utilize this product in the normal course of their business.

#### **DuPont Polyurethane Foam Insulation and Sealants**

**CAUTION:** When cured, these products are combustible and will burn if exposed to open flame or sparks from high-energy sources. Do not expose to temperatures above 240°F. For more information, consult (M)SDS call DuPont at 1-866-583-BLUE (2583) or contact your local building inspector. In an emergency, call 1-989-636-4400. When air sealing buildings, ensure that combustion appliances, such as furnaces, water heaters, wood burning stoves, gas stoves and gas dryers are properly vented to the outside. See website: <http://www.epa.gov/iaq/homes/hip-ventilation.html>. In Canada visit: <http://archive.nrc-cnrc.gc.ca/eng/ibp/irc/bsi/83-house-ventilation.html>.

Froth-Pak™ Spray Polyurethane Foam contains isocyanate, hydrofluorocarbon blowing agent and polyol. Read all instructions and (M)SDS carefully before use. Wear protective clothing and cover all skin (including long sleeves), gloves, goggles or safety glasses, and proper respiratory protection.

Do not breathe vapor or mist. Use only with adequate ventilation. It is recommended that applicators and those working in the spray area wear respiratory protection. Increased ventilation significantly reduces the potential for isocyanate exposure; however, supplied air or an approved air-purifying respirator equipped with an organic vapor sorbent and a particulate filter may still be required to maintain exposure levels below ACGIH, OSHA, WEEL or other applicable limits. For situations where the atmospheric levels may exceed the level for which an air-purifying respirator is effective, use a positive-pressure, air-supplying respirator (air line or self-contained breathing apparatus). Spraying large amounts of foam indoors may require the use of a positive pressure, air-supplying respirator. Contents under pressure. Building and/or construction practices unrelated to insulation could greatly affect moisture and the potential for mold formation. No material supplier including DuPont can give assurance that mold will not develop in any specific system.

DuPont™, the DuPont Oval Logo, and all trademarks and service marks denoted with ™, SM or ® are owned by affiliates of DuPont de Nemours, Inc. unless otherwise noted. © 2019 DuPont.

43-D100615-enNA-0619 CDP