

# ICC-ES Evaluation Report

ESR-4755

Reissued February 2026

This report also contains:

- [CA Supplement](#)

Subject to renewal February 2027

- [FL Supplement](#)

ICC-ES Evaluation Reports are not to be construed as representing aesthetics or any other attributes not specifically addressed, nor are they to be construed as an endorsement of the subject of the report or a recommendation for its use. There is no warranty by ICC Evaluation Service, LLC, express or implied, as to any finding or other matter in this report, or as to any product covered by the report.

Copyright © 2026 ICC Evaluation Service, LLC. All rights reserved.

<p><b>DIVISION: 07 00 00— THERMAL AND MOISTURE PROTECTION</b></p> <p><b>Section: 07 21 00— Thermal Insulation</b></p> <p><b>Section: 07 25 00— Water-Resistive Barriers/Weather Barriers</b></p> <p><b>Section: 07 27 00—Air Barriers</b></p>	<p><b>REPORT HOLDER:</b></p> <p><b>DUPONT DE NEMOURS, INC.</b></p>	<p><b>EVALUATION SUBJECT:</b></p> <p><b>STYROFOAM™ BRAND INSULATION BOARDS</b></p>	
---	--	--	---

## 1.0 EVALUATION SCOPE

### 1.1 Compliance with the following codes:

- 2024, 2021, 2018, 2015, 2012 and 2009 [International Building Code® \(IBC\)](#)
- 2024, 2021, 2018, 2015, 2012 and 2009 [International Residential Code® \(IRC\)](#)
- 2024, 2021, 2018, 2015, 2012 and 2009 [International Energy Conservation Code® \(IECC\)](#)
- Other Codes (see Section 8.0)

### Properties evaluated:

- Surface burning characteristics
- Attic installations
- Crawl space installations
- Air barrier
- Water-resistive barrier
- Thermal resistance
- Exterior walls in Types I-IV Construction
- Wind resistance (ANSI/FS 100)

### 1.2 Evaluation to the following green codes and/or standards:

- 2025 [California Green Building Standards Code \(CALGreen\)](#), Title 24, Part 11
- 2024, 2021, 2018, 2015 and 2012 [International Green Construction Code® \(IgCC\)](#)
- 2023, 2020, 2017, 2014 and 2011 [ANSI/ASHRAE/USGBC/IES Standard 189.1](#)—Standard for the Design of High-Performance Green Buildings, Except Low-Rise Residential Buildings
- 2020, 2015, 2012 and 2008 [ICC 700 National Green Building Standard™](#) (ICC 700-2020, ICC 700-2015, ICC 700-2012 and ICC 700-2008)

### Attributes verified:

See Section 2.0.

## 2.0 USES

Styrofoam™ Brand insulation boards are grey extruded polystyrene foam plastic boards used as nonstructural thermal insulating material in buildings of all construction types under the 2018, 2015, 2012 and 2009 IBC; in Type V construction under the 2024, 2021, 2018, 2015, 2012 and 2009 IBC; and dwellings under the IRC. The insulation is for use in wall assemblies, ceiling/floor assemblies, door cavities, roofs, foundations, attic and crawlspaces.

Styrofoam™ Brand Duramate™ Plus, Styrofoam™ Brand Residential Sheathing, Styrofoam™ Brand Residing Board, Styrofoam™ Brand UtilityFit, Styrofoam™ Brand Scoreboard, Styrofoam™ Brand Sheathing Material, Styrofoam™ Brand Cavitymate™ XR, and Styrofoam™ Brand Plazamate™ XR insulation boards may be used as alternatives to the water-resistive barriers specified in the IBC and IRC when installed in accordance with Section 4.4 and have been verified as conforming to the provisions of (i) CALGreen Section 5.407.1 for water-resistive barriers; (ii) 2024 and 2021 IgCC Section 701.3.1.2, 2018 IgCC Section 701.3.1.1 and 2015 and 2012 IgCC Section 605.1.2.1 for air barriers; (iv) 2023 and 2020 ASHRAE 189.1 Section 7.3.1.2, 2017 and 2014 ASHRAE 189.1 Section 7.3.1.1 and 2011 ASHRAE 189.1 Section 7.4.2.9 for air barriers; (v) ICC 700-2020 Sections 602.1.8, 11.602.1.8, 1202.6 and 13.104.1.4; (vi) ICC 700-2015 Section 602.1.8, 11.602.1.8 and 12.6.602.1.8; (vii) ICC 700-2012 Section 602.1.8, 11.602.1.8 and 12.5.602.1.8; and (viii) ICC 700-2008 Section 602.9 for water-resistive barriers.

The attributes of the insulation (excluding Styrofoam™ Brand Cavitymate™ XR and Styrofoam™ Brand Plazamate™ XR) have also been verified as conforming to the provisions of ICC 700-2008 Section 703.2.1.1.1(c) as an air impermeable insulation. Note that decisions on compliance for those areas rest with the user of this report. The user is advised of the project-specific provisions that may be contingent upon meeting specific conditions, and the verification of those conditions is outside the scope of this report. These codes or standards often provide supplemental information as guidance.

## 3.0 DESCRIPTION

### 3.1 Styrofoam™ Brand Insulation Boards:

Styrofoam™ Brand insulation boards are extruded polystyrene foam plastic complying with ASTM C578. The boards are available as various products having the product names and properties detailed in [Table 1](#). The boards are available in various lengths and widths and in thicknesses up to 4½ inches (114 mm). The actual board thickness provided is determined based on the *R*-value stated for the product.

### 3.2 Joint-sealing:

The joint-sealing treatments detailed in [Table 2](#), with the exception of Great Stuff™ Pro™ Gaps & Cracks which is promoted as an air barrier joint sealant treatment, are used in conjunction with Styrofoam™ Brand insulation boards to seal joints between two or more edges of boards, when the insulation boards are installed as a water resistive barrier or air barrier assembly. Great Stuff™ Pro™ Gaps & Cracks is used in conjunction with Styrofoam™ Brand insulation boards to seal joints between two or more edges of boards, when the insulation boards are installed as an air barrier assembly. Water-resistive barrier installations must be as described in Section 4.4 of this report. Air barrier assemblies must be as described in Section 4.6.2 of this report.

### 3.3 Surface Burning Characteristics:

Styrofoam™ Brand insulation boards have a flame-spread index (FSI) of 25 or less and a smoke-developed index (SDI) of 450 or less when tested in accordance with ASTM E84 (UL 723) at a maximum thickness of 4 inches (102 mm) and a maximum density of 3.8 pcf (61 kg/m³).

Styrofoam™ Brand Cavitymate™ XR and Styrofoam™ Brand Plazamate™ XR insulation boards have a flame-spread index (FSI) of 25 or less and a smoke-developed index (SDI) of 450 or less when tested in accordance with ASTM E84 (UL 723) at a maximum thickness of 4½ inches (114 mm) and a maximum density of 2.9 pcf (46.5 kg/m³).

### 3.4 Thermal Resistance:

Styrofoam™ Brand insulation boards and have a thermal resistance (*R*-value) as noted in [Table 1](#).

### 3.5 Air Permeability:

At a minimum thickness of ¼ inch (6.4 mm), the Styrofoam™ Brand insulation boards, except Styrofoam™ Brand Cavitymate™ XR and Styrofoam™ Brand Plazamate™ XR, are considered air-impermeable in accordance with 2024, 2021 and 2018 IBC Section 1202.3 (2015 IBC Section 1203.3) and 2024, 2021, 2018, 2015 and 2012 IRC Section R806.5 (2009 IRC Section R806.4), based on testing in accordance with ASTM E283.

## 4.0 INSTALLATION

### 4.1 General:

Styrofoam™ Brand insulation boards must be installed in accordance with the manufacturer's published installation instructions and this report. For the purposes of this report, the term "insulation board" is intended to refer to Styrofoam™ Brand insulation boards.

The installation of the insulation boards in areas of "very heavy" termite infestation probability must comply with 2024, 2021, 2018 and 2015 IBC Section 2603.8 [2012 IBC Section 2603.9 (2009 IBC Section 2603.8)] or 2024 IRC Section R305.4 (2021, 2018, 2015, 2012, and 2009 IRC Section R318.4). Under the IBC, protection against condensation must be provided in accordance with 2024, 2021 and 2018 IBC Section 1402.2 (2015, 2012 and 2009 IBC Section 1403.2); under the IRC, a vapor retarder must be provided in accordance with 2024, 2021, 2018, 2015 and 2012 IRC Section R702.7 (2009 IRC Section R601.3). Insulation boards must not be used as a nailing base for finish materials or wall covering materials. Fasteners used to attach exterior finish material over insulation boards must comply with a current ICC-ES evaluation report for proprietary wall covering materials, 2024, 2021 and 2018 IBC Section 1403 or 1404 (2015, 2012 or 2009 IBC Section 1404 or 1405), 2024, 2021, 2018 and 2015 IRC Table R703.3(1) (2012 and 2009 IRC Table R703.4), and the installation instructions from the finish manufacturer. For cementitious exterior wall coating applications, fasteners for insulation board thicker than 1½ inches (38 mm) must be considered for lateral resistance to ensure support for the exterior wall coatings.

Exterior wall assembly, exterior finish or a wall covering in conjunction with insulation boards must be structurally adequate to resist horizontal forces perpendicular to the wall. All walls must be braced in accordance with 2024, 2021 and 2018 IBC Section 2308 [2015 IBC Section 2308.6 (2012 and 2009 IBC Sections 2308.9.3 and 2308.12.4)], or IRC Section R602.10, as applicable. The insulation boards have been tested in accordance with the requirements of 2024, 2021, 2018 and 2015 IBC Section 2603.10 and ANSI/FS 100 for wind resistance when installed in accordance with Section 4.7.

When the insulation boards are applied over open framing, vertical butt joints must be over framing members. Vertical tongue-and-groove or shiplap joints need not be over framing members, provided joints are staggered a minimum of one stud space from adjacent courses. For cementitious exterior wall coating systems, unbacked joints are permitted only when specified in the ICC-ES evaluation report on the cementitious exterior wall coating system.

When installation is in an attic or crawl space, that attic or crawl space area must be separated from the interior of the building by an approved thermal barrier.

The foam must be installed as described in Section 4.3. Styrofoam™ Brand insulation boards, with the exception of Styrofoam™ Brand Cavitymate™ XR and Styrofoam™ Brand Plazamate™ XR, may be installed in unvented attics when the maximum thickness of the insulation boards is not less than ¼ inch (6.4 mm) in accordance with 2024, 2021, 2018, 2015 and 2012 IRC Section R806.5 (2009 IRC Section R806.4) or 2024, 2021 and 2018 IBC Section 1202.3 (2015 IBC Section 1203.3), as applicable.

### 4.2 Thermal Barrier Requirements:

**4.2.1 Application with a Prescriptive Thermal Barrier:** Styrofoam™ Brand insulation boards must be separated from the interior of the building by an approved thermal barrier as required in IBC Section 2603.4 or 2024 IRC Section R303.4 (2021, 2018, 2015, 2012 and 2009 IRC Section R316.4), as applicable.

### 4.3 Attics and Crawl Spaces – Ignition Barrier Requirements:

**4.3.1 Application with a Prescriptive Ignition Barrier:** When Styrofoam™ Brand insulation boards are installed within attics or crawl spaces where entry is made only for service of utilities, an ignition barrier must be installed in accordance with IBC Section 2603.4.1.6 or 2024 IRC Section R303.5.3 or R303.5.4 (2021, 2018, 2015, 2012 and 2009 IRC Section R316.5.3 or R316.5.4), as applicable. The ignition barrier must be consistent with the requirements for the type of construction required by the applicable code and must be installed in a manner so that the foam plastic insulation is not exposed.

### 4.4 Water-resistive Barrier:

The noted Styrofoam™ Brand insulation boards (Styrofoam™ Brand Duramate™ Plus, Styrofoam™ Brand Residential Sheathing, Styrofoam™ Brand Residing Board, Styrofoam™ Brand UtilityFit™, Styrofoam™ Brand Scoreboard, Styrofoam™ Brand Sheathing Material, Styrofoam™ Brand Square Edge, Styrofoam™ Brand Tongue and Groove, Styrofoam™ Brand Cavitymate™ Ultra, Styrofoam™ Brand Ultra SL, Styrofoam™ Brand Cavitymate™ XR, and Styrofoam™ Brand Plazamate™ XR) may be used as alternate water-resistive barriers as prescribed in 2024, 2021 and 2018 IBC Section 1403.2 (2015, 2012 and 2009 IBC Section 1404.2) and IRC Section R703.2, when installed on exterior walls as described in following sections:

**4.4.1** Styrofoam™ Brand insulation boards measuring 4 feet by 8 to 10 feet (1219 mm by 2438 to 3048 mm) are installed horizontally or vertically with long joints in contact with one another. Boards measuring 2 feet by 8 feet (610 mm by 2438 mm) are installed horizontally. When installed directly on wood-based framing members or over sheathing, framing members are spaced a maximum of 24 inches (610 mm) on center. The insulation boards are attached using  $\frac{3}{8}$ -inch-diameter head (9.5 mm) galvanized 11 or 12 gauge nails, 1-inch-crown (25.4 mm) galvanized staples with plastic washer or 1-inch-head (25.4 mm) plastic cap nails or equivalent fasteners long enough to penetrate wood-based framing a minimum of  $\frac{3}{4}$  inch (19.1 mm). Nails or staples must not be over-driven. Fastener spacing for boards measuring 4 feet by 8 to 10 feet (1219 mm by 2438 to 3048 mm) is a minimum of 12 inches (305 mm) on center around the perimeter and 16 inches (406 mm) on center in the field; for 2-foot-by-8-foot (610 mm by 2438 mm) boards, fastener spacing is a minimum of 12 inches (305 mm) on center on each stud (minimum three fasteners per stud).

For window installation, the installation must be in accordance with the window manufacturer's instructions. Minimum 3-inch-wide (76 mm) sub-sill flashing is used at the sill of windows, and minimum 2-inch-wide (51 mm) flashing is used to seal jambs and heads, unless window manufacturers have alternate instructions. See also [Figures 1](#) and [4](#). Fasteners for window installation must be sufficient length to achieve  $1\frac{1}{4}$  inch (32 mm) embedment into framing.

The seams and joints between boards must be covered or filled by one of the board joint sealing treatments identified in [Table 2](#).

Flashing of penetration items must be in accordance with the manufacturer's published install instructions. See [Figures 2](#), [3](#), [5](#), and [6](#).

**4.4.2** Styrofoam™ Brand insulation boards with a minimum thickness of 1 inch (25.4 mm) are installed horizontally or vertically with edge joints in contact with one another. The insulation boards must be installed directly on steel studs or over sheathing, framing members are spaced a maximum of 16 inches (406 mm) on center. The insulation boards must be attached with screws with diameter of 2 inches (51 mm) plastic caps or washers, long enough to penetrate the framing a minimum of 0.45 inch (11.4 mm) or as required by the fastener manufacturer and spaced a maximum of 16 inches (406 mm) on center in the field and 12 inches (305 mm) on center on the perimeter.

For window installation, the installation must be in accordance with the window manufacturer's installation instructions. See [Figures 1](#) and [4](#) for typical flashing details.

The seams and joints between boards must be covered or filled by one of the board joint sealing treatments identified in [Table 2](#).

Flashing of penetration items must be in accordance with the manufacturer's published installation instructions. See [Figures 2](#), [3](#), [5](#), and [6](#).

**4.4.3** Styrofoam™ Brand insulation boards are installed vertically or horizontally over concrete walls and attached with mechanical fasteners or Great Stuff™ Pro™ Gaps & Cracks Sealant. The boards are installed between rows of brick ties.

For window installation, the installation must be in accordance with the window manufacturer's installation instructions. See [Figures 1](#) and [4](#) for typical flashing details.

The seams and joints between boards must be covered or filled by one of the boards joint sealing treatments identified in [Table 2](#).

Flashing of penetration items must be in accordance with the manufacturer's published installation instructions. See [Figures 2](#), [3](#), [5](#) and [6](#).

#### **4.5 Use on Exterior Walls in Types I, II, III and IV Construction Under the 2018, 2015, 2012 and 2009 IBC:**

Styrofoam™ Brand insulation boards, except Styrofoam™ Brand Deckmate Plus, Styrofoam™ Brand Deckmate Plus FA and Styrofoam™ Brand Tongue and Groove, can be used on exterior walls of Types I, II, III and IV construction under the 2018, 2015, 2012 and 2009 IBC, and when installed in accordance with this report, the assembly must comply with Section 2603.5 of the 2018, 2015, 2012 and 2009 IBC and must be as described in [Table 4](#); the insulation boards must be installed in a single layer of insulation board at a maximum thickness of 3 inches. Alternatively, the insulation boards may be used in Types I, II, III and IV construction when specifically named in another ICC-ES evaluation report, in which case the insulation boards must be installed as described in that report. The potential heat of the ASTM C578 Type X and ASTM C578 Type IV Styrofoam™ foam plastic insulation board is 2384 Btu/ft<sup>2</sup> per inch of thickness (27.1 MJ/m<sup>2</sup>).

#### **4.6 Air Barrier:**

**4.6.1 Air Barrier Material:** Styrofoam Brand insulation boards, except Styrofoam™ Brand Cavitymate™ XR and Styrofoam™ Brand Plazamate™ XR, must be installed in accordance with the DuPont de Nemours, Inc.'s installation instructions and this report when used as an air barrier material.

**4.6.2 Air Barrier Assemblies:**

When installed on exterior walls as described in this section, the ASTM C578 Type X and ASTM C578 Type IV Styrofoam™ Brand, except Styrofoam™ Brand Cavitymate™ XR, foam plastic insulation is part of an air barrier assembly in accordance with 2024 IECC Section C402.6.2.3.2, [2021 IECC Section C402.5.1.4, (2018 and 2015 IECC Section C402.5.1.2.2), and (2012 IECC Section C402.4.1.2.2)], based on testing in accordance with ASTM E2357. The assembly qualifies as a continuous air barrier as prescribed in 2024 IECC Section C402.6.1 [2021, 2018 and 2015 IECC Section C402.5.1 (2012 IECC Section C402.4.1)].

**4.6.2.1** Styrofoam™ Brand insulation boards measuring 4 feet by 8 to 10 feet (1219 mm by 2438 to 3048 mm) are installed horizontally or vertically with long joints in contact with one another. Boards measuring 2 feet by 8 feet (610 mm by 2438 mm) are installed horizontally. When installed directly on wood-based framing members or over sheathing, framing members are spaced a maximum of 24 inches (610 mm) on center. The insulation boards are attached using <sup>3</sup>/<sub>8</sub>-inch-diameter head (9.5 mm) galvanized 11 or 12 gauge nails, 1-inch-crown (25.4 mm) galvanized staples with plastic washer or 1-inch-head (25.4 mm) plastic cap nails or equivalent fasteners long enough to penetrate wood-based framing a minimum of <sup>3</sup>/<sub>4</sub> inch (19.1 mm). Nails or staples must not be over-driven. Fastener spacing for boards measuring 4 feet by 8 to 10 feet (1219 mm by 2438 to 3048 mm) is a minimum of 12 inches (305 mm) on center around the perimeter and 16 inches (406 mm) on center in the field; for 2-foot-by-8-foot (610 mm by 2438 mm) boards, fastener spacing is a minimum of 12 inches (305 mm) on center on each stud (minimum three fasteners per stud).

For window installation, the installation must be in accordance with the window manufacturer's instructions. Minimum 2-inch-wide (51 mm) flashing is used to seal jambs and heads, unless window manufacturers have alternate instructions. See also [Figures 1](#) and [4](#). Fasteners for window installation must be sufficient length to achieve 1<sup>1</sup>/<sub>4</sub> inch (32 mm) embedment into framing.

The seams and joints between boards must be covered or filled by one of the boards joint sealing treatments identified in [Table 2](#).

Sealing of penetration items must be in accordance with the manufacturer's published installation instructions. See [Figures 2](#), [3](#), [5](#) and [6](#) in accordance with Item 3 of 2024 IECC Section C402.6.1.2 [2021, 2018 and 2015 IECC Section C402.5.1.1 (2012 IECC Section C402.4.2)].

**4.6.2.2** The Styrofoam™ Brand insulation boards with a minimum thickness of 1 inch (25.4 mm) in widths of 1<sup>1</sup>/<sub>2</sub> to 4 feet (457 to 1219 mm) and lengths of 8 to 10 feet (2438 to 3048mm), are installed horizontally or vertically with edge joints in contact with one another. When installed directly on steel studs or over sheathing, framing members are spaced a maximum of 16 inches (406 mm) on center. The insulation boards must be attached with screws with diameter of 2 inches (51 mm) plastic caps or washers, long enough to penetrate the framing a minimum of 0.45 inch (11.4 mm) or as required by the fastener manufacturer and spaced a maximum of 16 inches (406 mm) on center in the field and 12 inches (305 mm) on center on the perimeter.

For window installation, the installation must be in accordance with the window manufacturer's instructions. See [Figures 1](#) and [4](#) for typical exterior sealing details.

The seams and joints between boards must be covered or filled by one of the boards joint sealing treatments identified in [Table 2](#).

Sealing of penetration items must be in accordance with the manufacturer's published installation instructions. See [Figures 2](#), [3](#), [5](#) and [6](#), in accordance with Item 3 of 2024 IECC Section C402.6.1.2 [2021, 2018 and 2015 IECC Section C402.5.1.1 (2012 IECC Section C402.4.2)].

**4.6.2.3** Styrofoam™ Brand insulation boards are installed vertically or horizontally over concrete walls and attached with mechanical fasteners or Great Stuff Pro™ Gaps & Cracks Sealant. The boards are installed between rows of brick ties.

For window installation, the installation must be in accordance with the window manufacturer's instructions. See [Figures 1](#) and [4](#) for typical exterior sealing details.

The seams and joints between boards must be covered or filled by one of the boards joint sealing treatments identified in [Table 2](#).

Sealing penetration items must be in accordance with the manufacturer's published installation instructions. See [Figures 2](#), [3](#), [5](#) and [6](#) in accordance with Item 3 of 2024 IECC Section C402.6.1.2 [2021, 2018 and 2015 IECC Section C402.5.1.1 (2012 IECC Section C402.4.2)].

#### 4.7 Wind Resistance:

The Styrofoam™ Brand insulation boards have the wind resistance values noted in [Table 3](#) based on testing in accordance with ASTM E330 and ANSI/FS 100 as specified in 2024, 2021, 2018 and 2015 IBC Section 2603.10. The values are based on direct attachment to the type and spacing of wall framing described in [Table 3](#). The design and construction of the wall framing must comply with the applicable requirements of the IBC or IRC, as applicable, and [Table 3](#).

Attachment of the cladding over the Styrofoam™ Brand insulation boards must be in accordance with 2024 IBC Section 1404.5.3 and Table 1404.5.3.1 (2021 and 2018 IBC Section 2603.13 and Table 2603.13.1).

### 5.0 CONDITIONS OF USE:

The Styrofoam™ Brand insulation boards described in this report comply with, or are suitable alternatives to what is specified in, those codes listed in Section 1.0 of this report, subject to the following conditions:

- 5.1 Styrofoam™ Brand insulation boards must be installed in accordance with the manufacturer's published installation instructions, this evaluation report and the applicable code. In the event of a conflict between the installation instructions and this report, this report governs.
- 5.2 This evaluation report and the manufacturer's published installation instructions, when required by the code official, must be submitted at the time of permit application.
- 5.3 A water-resistive barrier complying with the requirements of the applicable code must be provided except when installation is as described in Section 4.4 of this report.
- 5.4 Use of the insulation boards to structurally resist transverse, racking-shear or vertical loading is outside the scope of this report. The walls must be braced in accordance with the requirements of the applicable code.
- 5.5 The insulation boards must not be used as a nailing base for exterior siding materials. All nailing must be into the wall framing as required by the siding manufacturer's instructions or the applicable code.
- 5.6 The insulation boards must be separated from the interior of the building by an approved thermal barrier.
- 5.7 Where required by the applicable code, a vapor retarder system, which may include the foam plastic insulation, must be installed in the exterior wall, floor, and/or roof ceiling assembly.
- 5.8 Jobsite certification and labeling of the insulation must comply with 2024, 2021, 2018 and 2015 IRC Section N1101.10.1 [2012 IRC Section N1101.12 (2009 IRC Section N1101.4)] and 2024, 2021, 2018, 2015 and 2012 IECC Sections C303.1.1, R303.1.1 and R401.3 (2009 IECC Section 303.1 and 401.3), as applicable.
- 5.9 Use of insulation in areas where the probability of termite infestation is "very heavy" must be in accordance with 2024, 2021, 2018, 2015 and 2009 IBC Section 2603.8 (2012 IBC Section 2603.9) or 2024 IRC Section R305.4 (2021, 2018, 2015, 2012, and 2009 IRC Section R318.4). When use is on exterior walls of buildings of Type I, II, III, or IV under the 2018, 2015, 2012 and 2009 IBC, construction must be as described in Section 4.5 and [Table 4](#).
- 5.10 Under the 2024 and 2021 IBC, use of Styrofoam™ Brand insulation boards on exterior walls of Types I, II, III and IV construction is outside the scope of this evaluation report.
- 5.11 Installation in unvented attics, when equipped with vapor diffusion ports in accordance with Section 1202.3, Item 5.2 of the 2024 and 2021 IBC and Section R806.5, Item 5.2 of the 2024, 2021 and 2018 IRC, is outside the scope of this report.
- 5.12 Styrofoam™ Brand Cavitymate™ XR and Styrofoam™ Brand Plazamate™ XR must not be used where air impermeable insulation is required.
- 5.13 Styrofoam™ Brand (Styrofoam™ Brand Duramate™ Plus, Styrofoam™ Brand Residential Sheathing, Styrofoam™ Brand Residing Board, Styrofoam™ Brand UtilityFit™, Styrofoam™ Brand Scoreboard, Styrofoam™ Brand Sheathing Material, Styrofoam™ Brand Square Edge, Styrofoam™ Brand Tongue and Groove, Styrofoam™ Brand Cavitymate Ultra, Styrofoam™ Brand Cavitymate, Styrofoam™ Brand Cavitymate Plus, Styrofoam™ Brand Ultra SL) insulation boards are manufactured in Burley, Idaho, Pevely, Missouri, Dalton, Georgia, Channahan, Illinois, and Varennes, Quebec under a quality-control program with inspections by ICC-ES.
- 5.14 Styrofoam™ Brand Cavitymate™ XR and Styrofoam™ Brand Plazamate™ XR are manufactured in Pevely, Missouri under a quality-control program with inspections by ICC-ES.

## 6.0 EVIDENCE SUBMITTED

- 6.1 Data in accordance with the [ICC-ES Acceptance Criteria for Foam Plastic Insulation \(AC12\)](#), dated June 2015 (editorially revised June 2024).
- 6.2 Data in accordance with the [ICC-ES Acceptance Criteria for Foam Plastic Sheathing Panels Used as Water-resistant Barriers \(AC71\)](#), dated February 2003 (editorially revised July 2024).
- 6.3 Reports of air leakage tests in accordance with ASTM E283 and ASTM E2357.
- 6.4 Report of potential heat test in accordance with NFPA 259.
- 6.5 Reports of fire propagation tests in accordance with NFPA 285.
- 6.6 Data in accordance with ANSI/FS 100 for wind resistance.

## 7.0 IDENTIFICATION

- 7.1 The ICC-ES mark of conformity, electronic labeling, or the evaluation report number (ICC-ES ESR-4755) along with the name, registered trademark, or registered logo of the report hold [DuPont de Nemours, Inc.] must be included in the product label.
- 7.2 In addition, the Styrofoam™ Brand insulation boards described in this report are identified by a label on the board or packaging material bearing the product name, plant code or manufacturing address and other information to confirm code compliance.  
  
DuPont™ Styrofoam™ Brand Tape, DuPont™ Flashing Tape, DuPont StraightFlash™, LiquidArmor™ LT, and LiquidArmor™ QS are identified with the product names. Great Stuff™ Pro™ Gaps & Cracks is labeled in accordance with ICC-ES ESR-1961.
- 7.3 The report holder's contact information is the following:

**DUPONT DE NEMOURS, INC.**  
**1501 LARKIN CENTER DRIVE**  
**MIDLAND, MICHIGAN 48642**  
**(866) 583-2583**  
[www.dupont.com](http://www.dupont.com)

## 8.0 OTHER CODES

In addition to the codes referenced in Section 1.0, the products described in this report were evaluated for compliance with the requirements of the following codes:

- 2006 *International Building Code*® (2006 IBC)
- 2006 *International Residential Code*® (2006 IRC)
- 2006 *International Energy Conservation Code*® (2006 IECC)

The products comply with the above-mentioned codes as described in Sections 2.0 through 7.0 of this report, with the revisions noted below:

- **General:** See Section 4.1, except the approved thermal barrier must be installed in accordance with Section R314.4 or R314.5 of the 2006 IRC.
- **Protection against Termites:** See Sections 4.1 and 5.9, except use of the insulation in areas where the probability of termite infestation is “very heavy” must be in accordance with Section 2603.8 of the 2006 IBC and Section R320.5 of the 2006 IRC.
- **Protection against Condensation:** See Section 4.1, except a vapor barrier must be provided in accordance with Sections R318 and N1102.5 of the 2006 IRC.
- **Jobsite Certification and Labeling:** See Section 5.8, except jobsite certification and labeling must comply with Section 102.1.2 of the 2006 IECC, when applicable.

TABLE 1—STYROFOAM™ BRAND INSULATION BOARDS

PRODUCT NAME	ASTM C578 TYPE <sup>1</sup>	R-VALUE, R / INCH (unless otherwise noted) at 75°F (ft <sup>2</sup> -hr-°F/Btu)
Styrofoam™ Brand Ag Board	IV	5.0
Styrofoam™ Brand Cavitymate™	X	5.0
Styrofoam™ Brand Cavitymate™ XR	IV	6.7
Styrofoam™ Brand Cavitymate™ Plus	IV	5.0
Styrofoam™ Brand Cavitymate™ SC	X	5.0
Styrofoam™ Brand Cavitymate™ Ultra	IV	10.0 at nominal 1 <sup>3</sup> / <sub>4</sub> " 12.0 at nominal 2 <sup>1</sup> / <sub>8</sub> " 14.0 at nominal 2 <sup>1</sup> / <sub>2</sub> " 16.8 at nominal 3" 19.6 at nominal 3 <sup>1</sup> / <sub>2</sub> "
Styrofoam™ Brand Deckmate™ Plus	IV	5.0
Styrofoam™ Brand Deckmate™ Plus FA	IV	5.0
Styrofoam™ Brand Duramate™ Plus	X	3.0 at nominal 1/2"
Styrofoam™ Brand Freezermate™	IV	5.0
Styrofoam™ Brand Freezermate™ 30	IV	5.0
Styrofoam™ Brand Freezermate™ 40	VI	5.0
Styrofoam™ Brand Freezermate™ 60	VII	5.0
Styrofoam™ Brand High-load 40	VI	5.0
Styrofoam™ Brand High-load 60	VII	5.0
Styrofoam™ Brand Lightguard Feedstock	VI	5.0
Styrofoam™ Brand Panel Core	X, IV, VI, VII	5.0
Styrofoam™ Brand Panelmate™ Plus	IV	5.0
Styrofoam™ Brand Perimate™	IV	5.0
Styrofoam™ Brand Plazamate™	VII	5.0
Styrofoam™ Brand Plazamate™ XR	VII	6.7
Styrofoam™ Brand Residential Sheathing R5	X	5.0 at nominal 1"
Styrofoam™ Brand Residential Sheathing R4	X	4.0 at nominal 3/4"
Styrofoam™ Brand Residential Sheathing R3	X	3.0 at nominal 1/2"
Styrofoam™ Brand Residing Board	X	2.8 at nominal 1/2"
Styrofoam™ Brand Ribbed Roofmate™	VI	5.0
Styrofoam™ Brand Roofmate™	VI	5.0
Styrofoam™ Brand Scoreboard	IV	5.0
Styrofoam™ Brand Sheathing Material	X, IV	5.0
Styrofoam™ Brand Square Edge	IV	5.0
Styrofoam™ Brand Square Edge R3	IV	3.0 at nominal 1/2"
Styrofoam™ Brand Square Edge R4	IV	4.0 at nominal 3/4"
Styrofoam™ Brand Tongue and Groove	IV	5.0
Styrofoam™ Brand Ultra SL	IV	10.0 at nominal 1 <sup>3</sup> / <sub>4</sub> " 12.0 at nominal 2 <sup>1</sup> / <sub>8</sub> " 14.0 at nominal 2 <sup>1</sup> / <sub>2</sub> " 16.8 at nominal 3" 19.6 at nominal 3 <sup>1</sup> / <sub>2</sub> "
Styrofoam™ Brand UtilityFit™	X	5.0

For SI: 1 inch = 25.4 mm, 1 pcf = 16.02 kg/m<sup>3</sup>, 1°F·ft<sup>2</sup>·hr/Btu = 0.176 m<sup>2</sup>·K/W, 1°F = 1.8°C+32.

<sup>1</sup>Type IV has a minimum density of 1.45 pcf, Type VI has a minimum density of 1.80 pcf.

<sup>2</sup>Type VII has a minimum density of 2.20 pcf, Type X has a minimum density of 1.30 pcf.

**TABLE 2—STYROFOAM™ BRAND INSULATION BOARD JOINT SEALING TREATMENTS**

JOINT SEALING TREATMENTS	MINIMUM APPLICATION WIDTH
DuPont™ Styrofoam™ Brand Tape	3 <sup>3</sup> / <sub>4</sub> "
DuPont™ Flashing Tape	4"
DuPont™ Straight Flash™	4"
LIQUIDARMOR™ LT	30 wet mil thickness 1" width, with 1/2" minimum width on each side of the joint, when covering a washer 1" minimum width to extend onto the substrate from the edge of the washer
LIQUIDARMOR™ QS	50 wet mil thickness 3" width, with 1" minimum width on each side of the joint when covering a washer 1" minimum width to extend onto the substrate from the edge of the washer
Great Stuff™ Pro™ Gaps & Cracks (ESR-1961)	Sufficient material to fully bridge the joint and ensure the sealant is fully adhered to the insulation boards on both side of the board joint

**TABLE 3—WIND PRESSURE RESISTANCE OF STYROFOAM™ BRAND INSULATION BOARDS**

PRODUCT NAME	THICKNESS (in.)	FASTENER SPACING <sup>1</sup> (in.)	FRAMING SPACING <sup>2,3</sup>	ALLOWAWABLE DESIGN LOAD (PSF) <sup>2</sup> [PEF=1.0]	DESIGN WIND SPEED (MPH) <sup>2</sup> [PEF=1.0]
Styrofoam™ Brand Residential Sheathing	1/2	6 Perimeter/12 Field	16 o.c.	29.9	140
Styrofoam™ Brand UtilityFit™	1	12 Perimeter/16 Field	16 o.c.	53.7	180

For **SI**: 1 inch = 25.4 mm, 1 psf = 4.8 kg/m<sup>2</sup>, 1mph = 1.609 k/h.

<sup>1</sup>Fasteners must be minimum 2 1/2" x 0.113" ring-shank nails with 1" plastic cap washers.

<sup>2</sup>Framing consists of minimum 2" x 4" wood studs, SPF species, Stud or No. 2 grade with the spacing as noted.

<sup>3</sup>Insulation must be installed with all edges supported by framing or blocking.

**TABLE 4—NFPA 285 COMPLYING WALL ASSEMBLIES FOR MAXIMUM 3-INCH-THICK ASTM C578 TYPE IV STYROFOAM™ INSULATION BOARD<sup>4,5</sup>**

Base Wall System – Use either 1, 2, or 3	1 – Concrete Wall 2 – Concrete masonry wall 3 – 1 layer of 1/2-inch or 5/8-inch Type X Gypsum Wall Board (on interior), installed over steel studs (minimum 3 5/8-inch deep, minimum No. 20-gage, maximum 16-inch o.c., lateral bracing every 4 ft. vertically)
Floorline Firestopping	4 pcf mineral wool in each stud cavity and at each floorline. Mineral wool to be attached with Z-clips or equivalent (See <a href="#">Figure 4</a> ).
Cavity Insulation – Use either 1, 2, or 3	1 – None 2 – Fiberglass batt insulation (faced or unfaced) 3 – Any non-combustible material
Exterior Sheathing – Use either 1, 2 or 3	1 – None 2 – 1/2-inch thick, exterior type gypsum sheathing 3 – 5/8-inch thick, Type X, exterior-type gypsum sheathing
Weather-Resistive Barrier Applied to Exterior Sheathing – Use 1 or 2	1 – None 2 – Any of the following <sup>2</sup> a. Air Bloc 31MR <sup>3</sup> – Henry Co. b. AIR-SHIELD™ LMP <sup>3</sup> (black only) – W.R. Meadows c. Backstop® NT <sup>3</sup> – Dryvit d. Barritech™ VP <sup>3</sup> – Carlisle e. CCW-705FR with CCW-702WB Primer <sup>3</sup> – Carlisle f. Fire-Resist Barritech™ NP <sup>3</sup> – Carlisle g. Green Guard® Max Building Wrap – Pactiv h. Perm-A-Barrier® Aluminum Wall Membrane with WB Primer <sup>3</sup> – Grace Construction Products i. Perm-A-Barrier® VPS <sup>3</sup> – Grace Construction Products j. Tyvek® CommercialWrap® ( <a href="#">ESR-2375</a> ) k. Tyvek® Fluid Applied WB+™ – DuPont l. Wall Guardian™ FW100A <sup>2</sup> – STS Inc. m. Weathermate™ ( <a href="#">ESR-2862</a> ) n. Weathermate™ Plus ( <a href="#">ESR-3401</a> )  Note: All barriers to be installed at recommended application rates per manufacturer’s installation instructions.
Exterior Insulation	ASTM C578 Type IV Styrofoam™ Brand <sup>1</sup> insulation board: 1/2-inch (minimum) to 3-inch (maximum). Insulation board joints may be covered with 4-inch (maximum) wide asphalt or butyl-based flashing tape
Flashing	Flash all exterior insulation joints and veneer tie penetrations with one of the following: 1 – LiquidArmor™ LT – Minimum 1-inch-wide with a minimum 25 wet mils 2 – LiquidArmor™ QS – Minimum 2-inch-wide with a minimum 45 wet mils
Weather-Resistive Barrier <sup>2</sup> Applied to Exterior Insulation – Use 1, 2, 3, 4 or 5	1 – None 2 – Green Guard® Max Building Wrap – Pactiv 3 – Tyvek® CommercialWrap® ( <a href="#">ESR-2375</a> ) 4 – Weathermate™ ( <a href="#">ESR-2862</a> ) 5 – Weathermate™ Plus ( <a href="#">ESR-3401</a> )
Exterior Veneer – Use 1, 2, 3, 4, 5 or 6	1 – Brick. Use standard nominal 4-inch thick, clay brick. Use standard brick veneer anchors installed vertically on each stud at a maximum of 24-inch o.c. creating a 2-inch maximum air gap between the exterior insulation and brick. 2 – Concrete – Minimum 2-inch thick, with a 2-inch maximum air gap between exterior insulation and concrete. 3 – Concrete masonry units - minimum 4-inch thick, with a 2-inch maximum air gap between exterior insulation and concrete masonry units. 3 – Limestone – minimum 2-inch thick installed using any standard non-open-joint installation technique such as shiplap. 4 - Natural stone veneer – minimum 2-inch thick installed using any standard non-open-joint installation technique such as shiplap. 5 – Pre-cast artificial stone complying with ICC-ES AC51 – minimum 1 1/2-inch thick installed using any standard non-open-joint installation technique such as shiplap. 6 – Terracotta cladding – minimum 1 1/4-inch thick installed using any standard non-open-joint installation technique such as shiplap.
Special Conditions	Use header treatment shown in <a href="#">Figures 5, 6 and 7</a> for all window and door openings in wall.

<sup>1</sup>ASTM C578 Type IV Styrofoam™ Brand Insulation boards except Styrofoam™ Brand Deckmate™ Plus, Styrofoam™ Brand Deckmate™ Plus FA and Styrofoam™ Brand Tongue and Groove.

<sup>2</sup>A code-complying water-resistive barrier must be provided, either over the sheathing or over the exterior insulation.

<sup>3</sup>This material was evaluated by ICC-ES to comply with Section 2603.5 of the IBC, when used as part of the wall assemblies outlined in [Table 3](#), but has not been evaluated for use as a water-resistive barrier under Section 1404.2 of the IBC and Section R703.2 of the IRC.

<sup>4</sup>When used on exterior walls of Types I, II, III or IV construction, the specific wall assembly must comply with 2018, 2015, 2012 and 2009 IBC Section 2603.5.

<sup>5</sup>The exterior wall assemblies described in [Table 4](#) comply with 2018, 2015, 2012 and 2009 IBC Section 2603.5.5.

Step 1

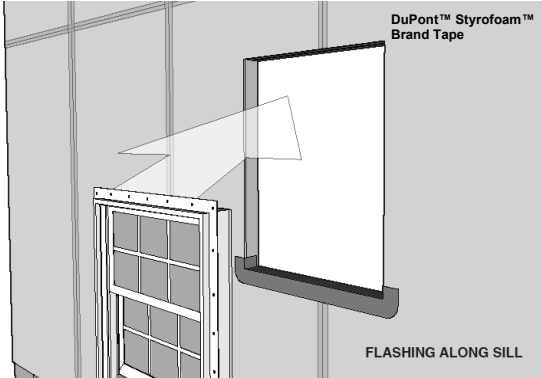

Step 2

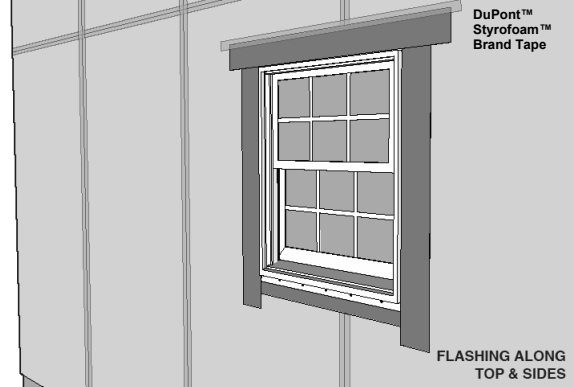
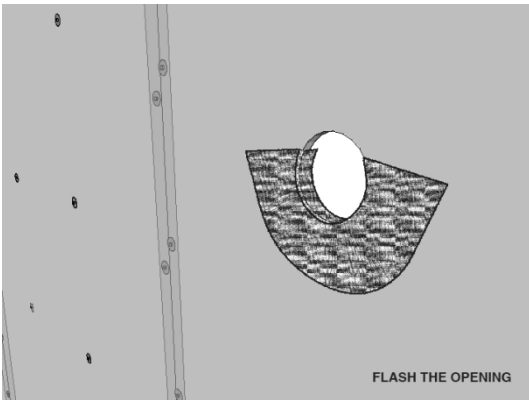

FIGURE 1—TYPICAL WINDOW FLASHING DETAIL

Step 1



Step 2

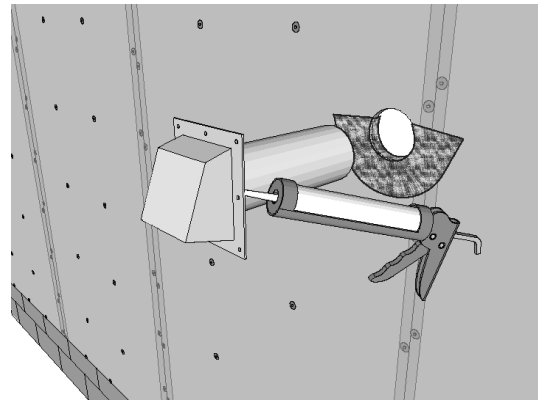

FIGURE 2—TYPICAL PENETRATION FLASHING DETAIL – FLANGED

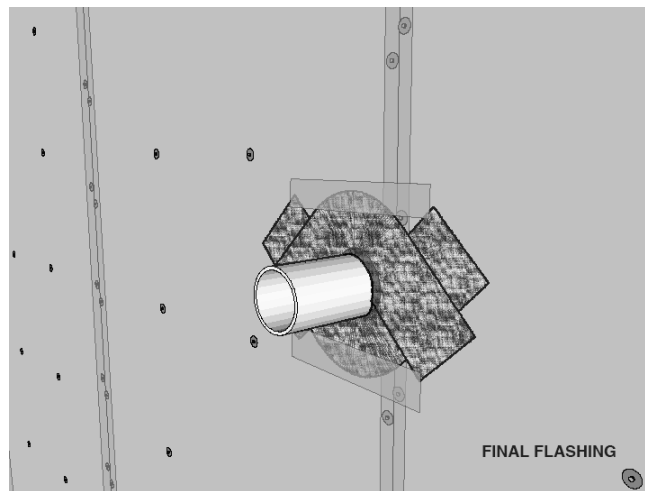

FIGURE 3—TYPICAL FLASHING DETAIL – UNFLANGED

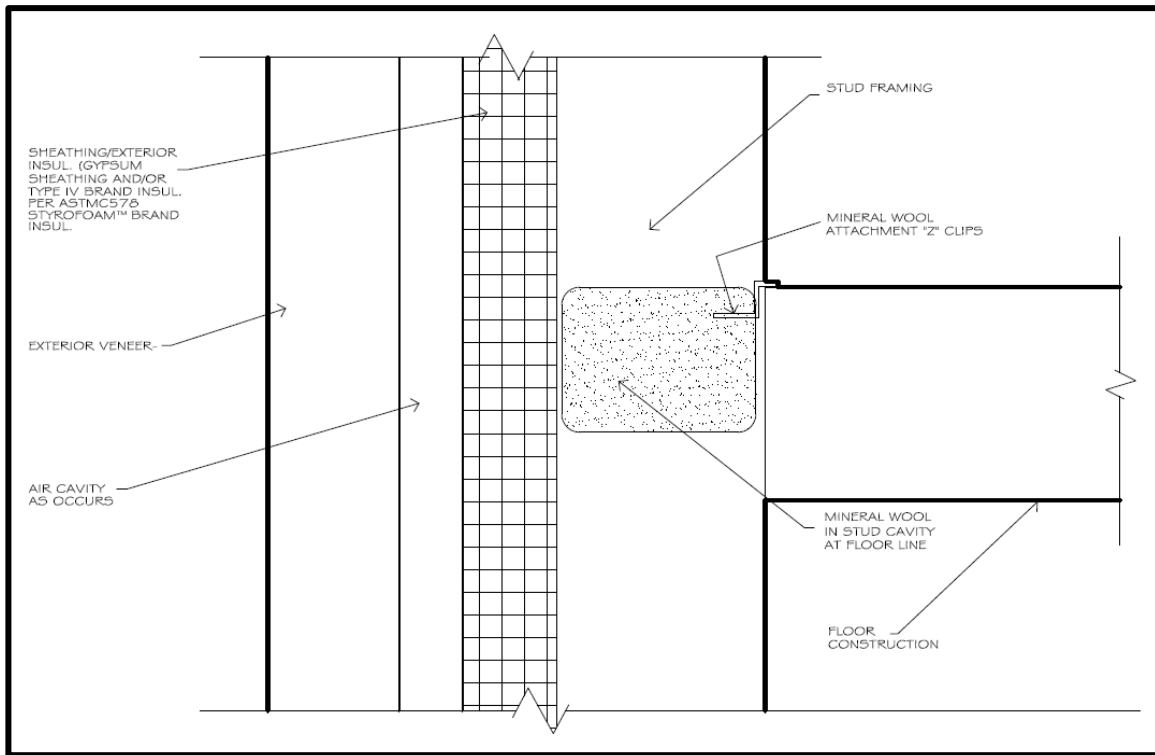

FIGURE 4—FLOORLINE FIRESTOPPING



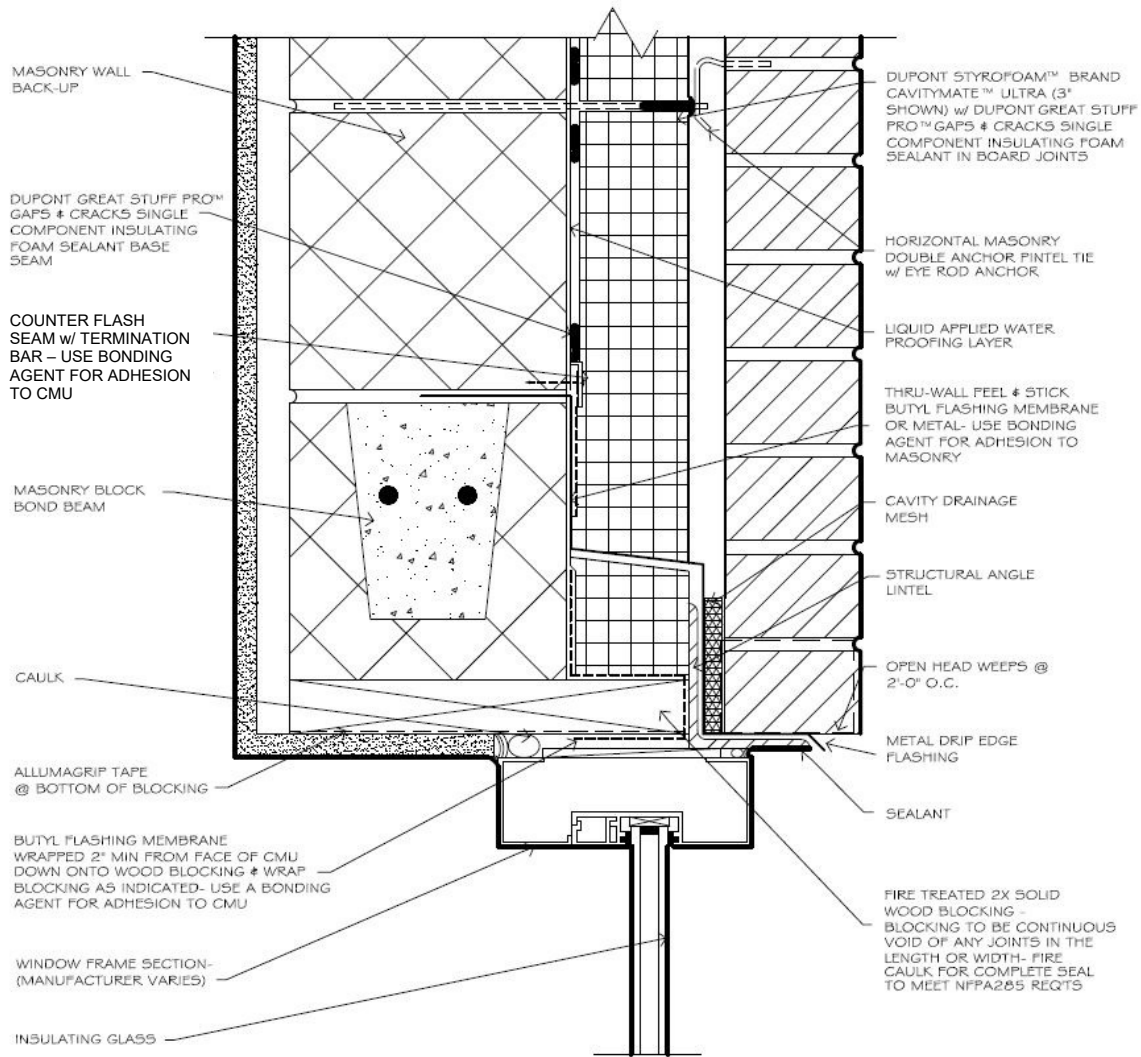

FIGURE 6—WINDOW HEAD DETAIL—FRTW WOOD BLOCKING—MASONRY WALL

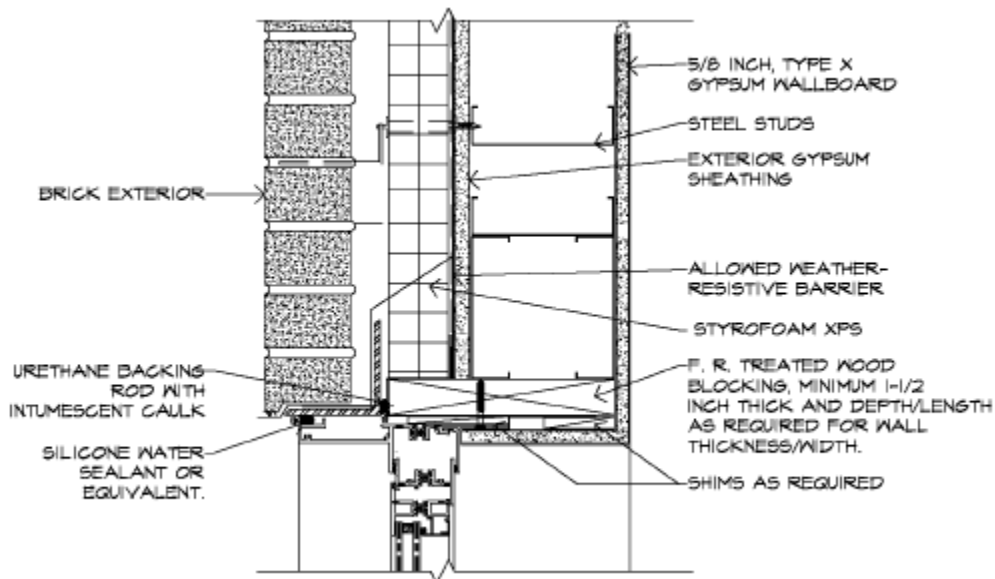

FIGURE 7—WINDOW HEAD DETAIL—FRTW WOOD BLOCKING—FRAMED WALL

**DIVISION: 07 00 00—THERMAL AND MOISTURE PROTECTION**  
**Section: 07 21 00—Thermal Insulation**  
**Section: 07 25 00— Water-Resistive Barriers/Weather Barriers**  
**Section: 07 27 00— Air Barriers**

**REPORT HOLDER:**

DUPONT DE NEMOURS, INC.

**EVALUATION SUBJECT:**

STYROFOAM™ BRAND INSULATION BOARDS

**1.0 REPORT PURPOSE AND SCOPE****Purpose:**

The purpose of this evaluation report supplement is to indicate that Styrofoam™ Brand insulation boards (except Styrofoam™ Brand Residing Board), described in ICC-ES evaluation report [ESR-4755](#), have also been evaluated for compliance with the codes noted below.

**Applicable code editions:**

- 2025 and 2022 *California Building Code* (CBC)

For evaluation of applicable chapters adopted by the California Office of Statewide Health Planning and Development (OSHPD) AKA: California Department of Health Care Access and Information (HCAI) and the Division of State Architect (DSA), see Sections 2.1.1 and 2.1.2 below.

- 2025 and 2022 *California Residential Code* (CRC)
- 2025 and 2022 *California Energy Code* (CEC)

**2.0 CONCLUSIONS****2.1 CBC and CRC:**

The Styrofoam™ Brand insulation boards (except Styrofoam™ Brand Residing Board), described in Sections 2.0 through 7.0 of the evaluation report [ESR-4755](#), comply with the 2025 and 2022 CBC and 2025 and 2022 CRC, provided the design and installation are in accordance with the 2024 and 2021 *International Building Code*® (IBC) and 2024 and 2021 *International Residential Code*® (IRC) provisions, as applicable, noted in the evaluation report.

**2.1.1 OSHPD:**

The applicable OSHPD Sections and Chapters of the CBC are beyond the scope of this supplement.

**2.1.2 DSA:**

The applicable DSA Sections and Chapters of the CBC are beyond the scope of this supplement.

**2.2 CEC:**

The Styrofoam™ Brand insulation boards (except Styrofoam™ Brand Residing Board), described in Sections 2.0 through 7.0 of the evaluation report [ESR-4755](#), comply with the 2025 and 2022 CEC, provided the design and installation are in accordance with the 2024 and 2021 *International Building Code*® (IBC) and 2024 and 2021 *International Residential Code*® (IRC) provisions, as applicable, noted in the evaluation report.

**2.2.1 Conditions of Use:**

In accordance with Section 110.8 of the 2025 and 2022 California Energy Code, verification of certification by the Department of Consumer Affairs, Bureau of Household Goods and Services, must be provided to the code official, demonstrating that the insulation conductive thermal performance is approved pursuant to the California Code of Regulations, Title 24, Part 12, Chapters 12-13, Article 3, "Standards for Insulating Material." Certification can be verified with the DCA Bureau of Household Goods and Services using the following link to the bureau's Directory of Certified Insulation Materials: [https://bhgs.dca.ca.gov/consumers/ti\\_directory.pdf](https://bhgs.dca.ca.gov/consumers/ti_directory.pdf)

This supplement expires concurrently with the evaluation report, reissued February 2026.

**DIVISION: 07 00 00—THERMAL AND MOISTURE PROTECTION**  
**Section: 07 21 00—Thermal Insulation**  
**Section: 07 25 00—Water-Resistive Barriers/Weather Barriers**  
**Section: 07 27 00—Air Barriers**

**REPORT HOLDER:**

DUPONT DE NEMOURS, INC.

**EVALUATION SUBJECT:**

STYROFOAM™ BRAND INSULATION BOARDS

**1.0 REPORT PURPOSE AND SCOPE****Purpose:**

The purpose of this evaluation report supplement is to indicate that Styrofoam™ Brand insulation boards, described in ICC-ES evaluation report [ESR-4755](#), have also been evaluated for compliance with the codes noted below.

**Applicable code editions:**

- 2023 Florida Building Code—Building
- 2023 Florida Building Code—Residential

**2.0 CONCLUSIONS**

The Styrofoam™ Brand insulation boards, described in Sections 2.0 through 7.0 of ICC-ES evaluation report [ESR-4755](#), complies with the 2023 Florida Building Codes—Building and 2023 Florida Building Code—Residential. The design requirements shall be determined in accordance with the Florida Building Code—Building or the Florida Building Code—Residential, as applicable. The installation requirements noted in ICC-ES evaluation report [ESR-4755](#) for the 2021 International Building Code® meet the requirements of the Florida Building Code—Building or the Florida Building Code—Residential, as applicable, with the following conditions:

1. Use of the insulation boards to resist structural loads is outside the scope of this report. The walls must be braced in accordance with the requirements of the Florida Building Codes—Building or the Florida Building Code—Residential, as applicable.
2. At a minimum thickness of 1/4 inch (6.4 mm), the Styrofoam™ Brand insulation boards, except Styrofoam™ Brand Cavymate™ XR and Styrofoam™ Brand Plazamate™ XR, are considered air-impermeable in accordance with Florida Building Code—Building Section 1203.3 and Florida Building Code—Residential Section R806.5.
3. Installation must meet the requirements of Section 1403.8 and 2603.8 of the Florida Building Codes—Building and Section R318.7 and R318.8 of the Florida Building Code—Residential Section R316.4, as applicable.
4. The insulation boards noted in Section 4.4 of the evaluation report may be used as alternate water-resistive barriers as prescribed in Florida Building Code—Building Section 1404.2 and Florida Building Code—Residential Section R703.2, when installed on exterior walls as described in Section 4.4.1 through 4.4.3 of the evaluation report.

Use of the Styrofoam™ Brand insulation boards for compliance with the High-Velocity Hurricane Zone provisions of the Florida Building Code—Building or the Florida Building Code—Residential has not been evaluated and is outside the scope of this supplemental report.

For products falling under Florida Rule 61G20-3, verification that the report holder's quality assurance program is audited by a quality assurance entity approved by the Florida Building Commission for the type of inspections being conducted is the responsibility of an approved validation entity (or the code official when the report holder does not possess an approval by the Commission). Florida Rule 61G20-3 is applicable to products and/or systems which comprise the building envelope and structural frame for compliance with the structural requirements of the Florida Building Code.

This supplement expires concurrently with the evaluation report, reissued February 2027.