

# DuPont™ Thermax™ White Finish Insulation

## Installation Procedures

### SYSTEM OVERVIEW

#### Description

Owners of agricultural buildings that house animals, produce or equipment know that controlling the indoor temperature and humidity is a smart way to protect their investment. Easy-to-install **DuPont™ Thermax™ White Finish Insulation** offers thermal and moisture protection that can be used as an exposed interior finish and insulation on walls and roofs. **Thermax™ White Finish Insulation** boards consist of a core of glass fiber-reinforced polyisocyanurate foam. The front has a durable nominal 1.25 mil embossed white acrylic coated aluminum facer that can be pressure-washed, while the back side is faced with 1.25 mil smooth aluminum.

There are three methods that can be used to install **Thermax™ White Finish Insulation**. Each system is outlined here.

#### Materials Checklist

- Utility knife or small handsaw
- Straight edge
- Measuring tape
- Pencil
- Construction-grade sealant
- **DuPont™ Thermax™ White Foil Tape**
- Squeegee or soft paint roller
- Hammer, pneumatic fastener or screwdriver
- PVC Clip Strips
- Fasteners and poly washers (such as QUIK Cap Washer-Plastic Round or Buildex Multi-Diameter Insulation Tekes)
- Polyisocyanurate-compatible polyurethane spray sealant, such as **Great Stuff Pro™ Gaps & Cracks Polyurethane Foam Sealant\***
- Safety glasses

#### General Information

- **Thermax™ White Finish Insulation** must be kept dry at all times. Protect it from moisture both in storage and during installation.
- With its tough, embossed white acrylic-coated surface, **Thermax™ White Finish Insulation** can be pressurewashed at 800 psi (3' distance) using 15 degree spray tip.
- Install **Thermax™ White Finish Insulation** with the white acryliccoated side exposed.
- **Thermax™ White Finish** board joints must be sealed with **DuPont™ Thermax™ White Foil Tape**. Before applying tape, wipe the application area with a damp cloth to remove foam dust. Allow surface to air dry.
- Use a squeegee or soft paint roller to press the tape firmly to the joint. Cut tape with a knife or scissors. Do not tear tape. Taping serves as a protection against moisture penetration and gives the exterior of the boards a continuous surface.
- End-joint gaps greater than 1/8" should be filled with spray foam such as **Great Stuff Pro™ Gaps & Cracks Polyurethane Foam Sealant** or equivalent to keep a continuous air infiltration barrier and to help ensure maximum thermal efficiency across the board joints. To increase the moisture effectiveness of the board joints, apply **Thermax™ White Foil Tape** over the sprayed board joints.
- There are two ways to cut **Thermax™ White Finish Insulation** boards. One way is to use a straight edge and a utility knife, making sure to cut all the way through the facing. Or, **Thermax™ White Finish** boards may be cut with a small handsaw.

#### Securement

Install a minimum 1" **Thermax™ White Finish Insulation** board perpendicular to framing, spanning at least three framing members. Penetrate separate wood and metal framing 1" with a corrosion resistant fastener and poly washer, such as QUIK Cap, following the fastening pattern shown in Figure 4.

When fastening to metal, Buildex Multi-Diameter Insulation Tekes or equivalent (with minimum 1-1/4" poly washers) are advised.

## INSTALLATION

### Good System

Leave square edge joints untreated. Tape the back side of the joint with DuPont™ Thermax™ White Foil Tape (Figure 1).

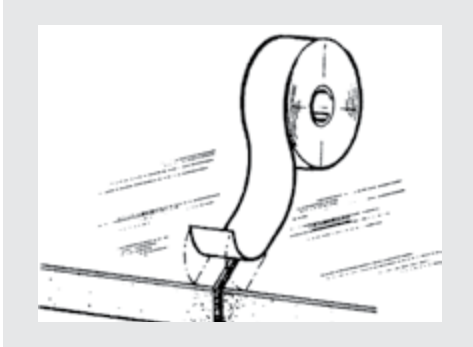

Figure 1.

### Better System

Use a compatible construction grade sealant to join the factory produced shiplapped joint as well as the end joints over roof or wall framing (Figure 2). Orient the shiplapped joint so that the exposed side has a shingle fashion joint with the uphill lap on top of the downhill lap. The shiplapped edge may leave an uneven joint on the exposed side. Taping the back side of the joint with Thermax™ White Foil Tape will help protect against moisture penetration and provide a continuous surface.

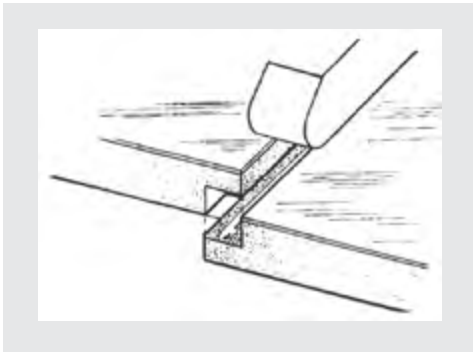

Figure 2.

### Best System

Apply a compatible construction grade sealant to the PVC Clip Strip and install on exposed joint (Figure 3). Tape the back side of the joint with Thermax™ White Foil Tape.

In roof systems where the temperature of the roof exceeds 150°F, it is recommended to use two layers of Thermax™ White Finish Insulation to separate the Clip Strip from a roof system's exterior metal.

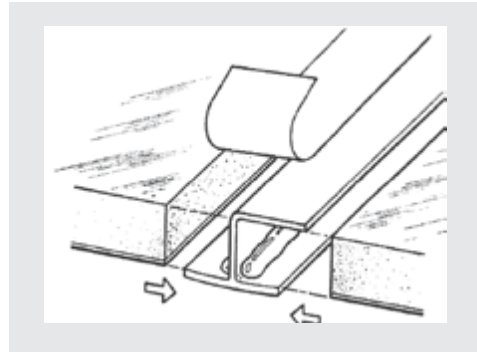

Figure 3.

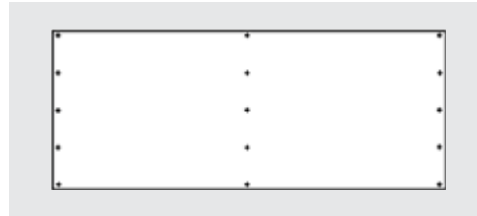

Figure 4. Fastening Pattern: Space fasteners 24" oc along the width of the board and 48" oc along the length of the board.

Note: For FM Insured buildings, please reference the latest FM document for fastening pattern.



For more information visit  
[thermaxwallsystem.com](http://thermaxwallsystem.com)  
or call 1-866-583-2583

**NOTICE:** No freedom from any patent owned by DuPont or others is to be inferred. Because use conditions and applicable laws may differ from one location to another and may change with time, Customer is responsible for determining whether products and the information in this document are appropriate for Customer's use and for ensuring that Customer's workplace and disposal practices are in compliance with applicable laws and other government enactments. The product shown in this literature may not be available for sale and/or available in all geographies where DuPont is represented. The claims made may not have been approved for use in all countries or regions. DuPont assumes no obligation or liability for the information in this document. References to "DuPont" or the "Company" mean the DuPont legal entity selling the products to Customer unless otherwise expressly noted. NO EXPRESS WARRANTIES ARE GIVEN EXCEPT FOR ANY APPLICABLE WRITTEN WARRANTIES SPECIFICALLY PROVIDED BY DUPONT. ALL IMPLIED WARRANTIES INCLUDING THOSE OF MERCHANTABILITY AND FITNESS FOR A PARTICULAR PURPOSE ARE EXPRESSLY EXCLUDED. The buyer assumes all risks as to the use of the material. Buyer's exclusive remedy or any claim (including without limitations, negligence, strict liability, or tort) shall be limited to the refund of the purchase price of the material. Failure to strictly adhere to any recommended procedures shall release DuPont Specialty Products USA, LLC or its affiliates, of all liability with respect to the materials or the use thereof. The information herein is not intended for use by non-professional designers, applicators or other persons who do not purchase or utilize this product in the normal course of their business.

**CAUTION:** When cured, these products are combustible and will burn if exposed to open flame or sparks from high-energy sources. Do not expose to temperatures above 240°F (116°C). For more information call the DuPont Contact Center at 866-583-2583 or contact your local building inspector. For emergencies contact Chemtrec 800-424-9300, CCN (Contract Number) 7442. The blowing agent contained within this product can exhibit vapor flame limits under the right conditions. If specific operating conditions are such that concentrations of the blowing agent above the lower flammable limit can accumulate in areas with high relative humidity and in the presence of high-energy electrical discharges or other ignition sources, additional measures such as increased ventilation or coded electrical equipment (class one, division two) may be warranted. DO NOT SMOKE DURING USE. DO NOT USE NEAR ANY OPEN FLAME OR ELECTRICAL SOURCE. OUTDOOR USE ONLY. INDOOR USE INCREASES LIKELIHOOD OF IGNITABLE CONDITIONS. INSTASTIK™ Quik Set Commercial Roofing Adhesive contains isocyanate and a blowing agent. Read the label and (Material) Safety Data Sheet (MSDS) carefully before use. Wear gloves, and goggles or safety glasses. Provide adequate ventilation or wear proper respiratory protection. Contents under pressure. For outside use only.

Thermax™ products should be used only in strict accordance with product application instructions. Thermax products, when used in a building containing combustible materials, may contribute to the spread of fire. For more information, consult MSDS and/or call DuPont at 1-866-583-2583.

**WARNING:** Thermax insulation does not constitute a working walkable surface or qualify as a fall protection product.

Building and/or construction practices unrelated to insulation could greatly affect moisture and the potential for mold formation. No material supplier including DuPont can give assurance that mold will not develop in any specific system.

DuPont™, the DuPont Oval Logo, and all trademarks and service marks denoted with ™, SM or ® are owned by affiliates of DuPont de Nemours, Inc. unless otherwise noted. © 2023 DuPont.