

Technical Bulletin # 1600C

Bulletin Description

The following grout installation instructions apply to standard ESCOWELD Epoxy Grout applications on concrete foundations where the grout thickness is within the specified range. Outside this range, please consult your CHOCKFAST distributor for guidance.

Material Check List

The following materials are required to effectively install ESCOWELD epoxy grout. Assemble all materials prior to starting any work.

1. Adequate supply of ESCOWELD 7505E/7530 Epoxy Grout. We recommend ordering 10% to 15% extra to account for spillage, waste, etc. depending on location of distributor.
2. Protective covering for floors and equipment.
3. Air compressor, hoses, chipping gun and auxiliary lighting.
4. Dust masks, goggles, hard hats, rubber gloves and ear protection. Also check with on-site safety personnel for safety equipment requirements.
5. Industrial vacuum cleaner.
6. Replacement anchor bolts if needed.
7. Sandblasting equipment, ventilation equipment if necessary.
8. Tape or split hoses for isolating anchor bolts from grout.
9. Forming materials: lumber, Styrofoam, chamfer strips, nails, putty, weather stripping, paste wax and carpenters tools.
10. Grout mixing equipment: Wheelbarrows, mortar hoes and buckets or mechanical mortar mixer if required.
11. Warm soapy water or clean-up solvent and rags for clean up only.
12. An adequate number of people to help mix and install the grout.

Surface Preparation

For the foundation to successfully absorb vibration from the equipment there must be a solid connection from the equipment down through the baseplate and foundation and into the soil underneath. This requires a solid connection between the epoxy grout and the baseplate as well as the epoxy grout and the concrete foundation. The recommendations below are provided to help ensure this connection exists.

1. Metal surfaces to be in contact with the ESCOWELD 7505E/7530 Epoxy Grout should be dry and free of grease, paint and rust for optimum bonding. A bright metal surface can be obtained by sandblasting or grinding. In high humidity areas, equipment should be grouted immediately after sandblasting or grinding. If immediate grouting is not practical, these surfaces should be protected with a thin coat of ITW Rust Inhibitive Primer.
2. Concrete on which the grout will bear should have attained its design strength and shrinkage before grouting. The design strength, curing information and shrinkage information is available from the concrete supplier. All concrete surfaces that are to come into contact with ESCOWELD 7505E/7530 Epoxy Grout should be chipped approximately 1 inch in depth to remove laitance and provide a rough surface for good bonding and shear strength. If concrete is oil soaked, chip away concrete until oil or contaminants are removed. Only sound concrete is acceptable.
3. All shims, leveling screws, wedges and blocks that will eventually be removed from the installation should be covered with putty or wax prior to pouring ESCOWELD 7505E/7530 Epoxy Grout.

4. Pouring around anchor bolts completely with ESCOWELD 7505E/7530 Epoxy Grout restricts the spring effect capabilities of the full length of the bolt and should be avoided as follows:
 - a. Anchor bolt sleeves should be packed with foam rubber, spray urethane foam, asphalt or other non-bonding material.
 - b. Anchor bolts should be wrapped to provide a barrier between the ESCOWELD 7505E/7530 Epoxy Grout and the anchor bolts.

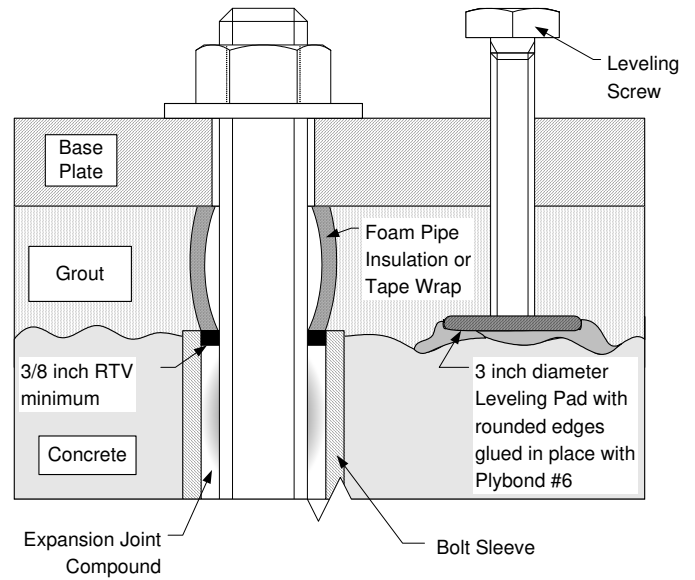

Forming Instructions

Forms to contain the epoxy grout are typically made from $\frac{3}{4}$ inch plywood and 2x4's and 2x6's. The following are some recommendations to improve the quality of the formwork.

1. For embedded machines, forms to contain ESCOWELD 7505E/7530 Epoxy Grout should be designed to provide a grout level of one-inch minimum above the engine frame bottom and to chamfer the outside edge of the grout. For rail or soleplate mounted machines, forms shall be designed to provide a grout level of $\frac{1}{4}$ inch minimum below the top of the rails or soleplates.
2. Forms should be liquid tight to prevent loss of epoxy grout materials. Any open spaces or cracks in forms at the joints or between forms and the foundation block should be sealed off using putty or duct seal.
3. All form material should be coated with 3 coats of heavy paste wax on all areas that will come into contact with ESCOWELD 7505E/7530 Epoxy Grout to prevent bonding.
4. For engines having a V-shaped oil pan, a seal may be made using a waxed or polyethylene wrapped fire hose to prevent the grout from leaking under the crankcase. The

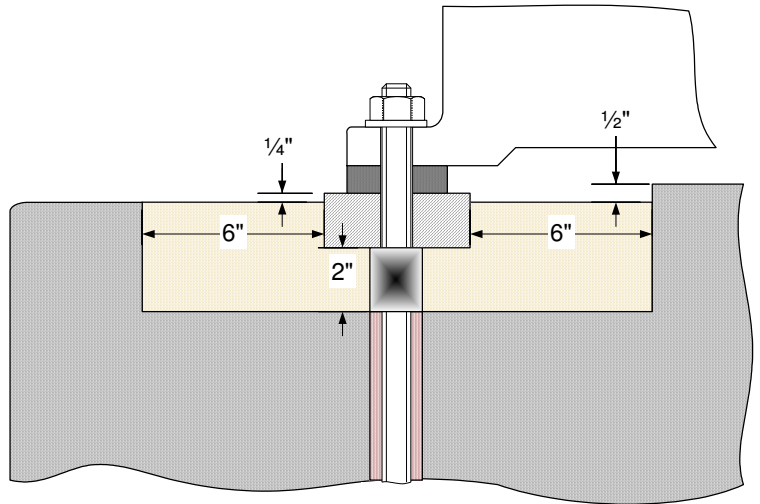

Rail / Soleplate Installation

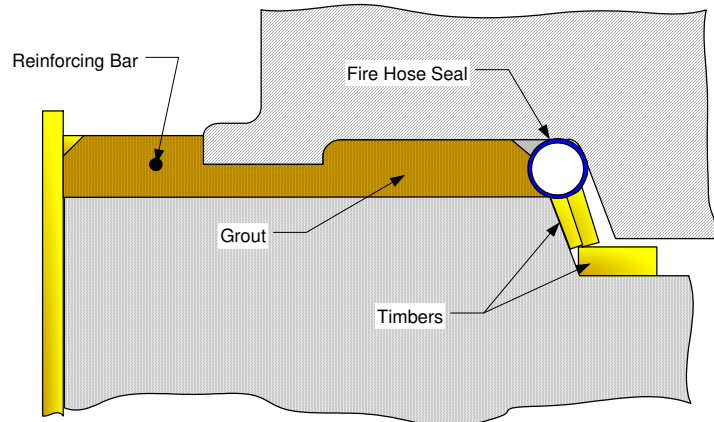

A typical embedded installation where the grouted surface is narrow and grout does not have to flow a great distance.

- hose should be inflated with water not to exceed 10 psi.
- Any sand, dust or other foreign material shall be removed from the foundation top after forming and sealing are complete.
 - Surfaces of machine-base rails or soleplates that are to be embedded in grout should be cleaned using a wiping cloth dampened with IMPAX IXT-59 Cleaning Solvent
 - Leveling screws should be coated with non-melt grease or a heavy wax film prior to pouring grout.

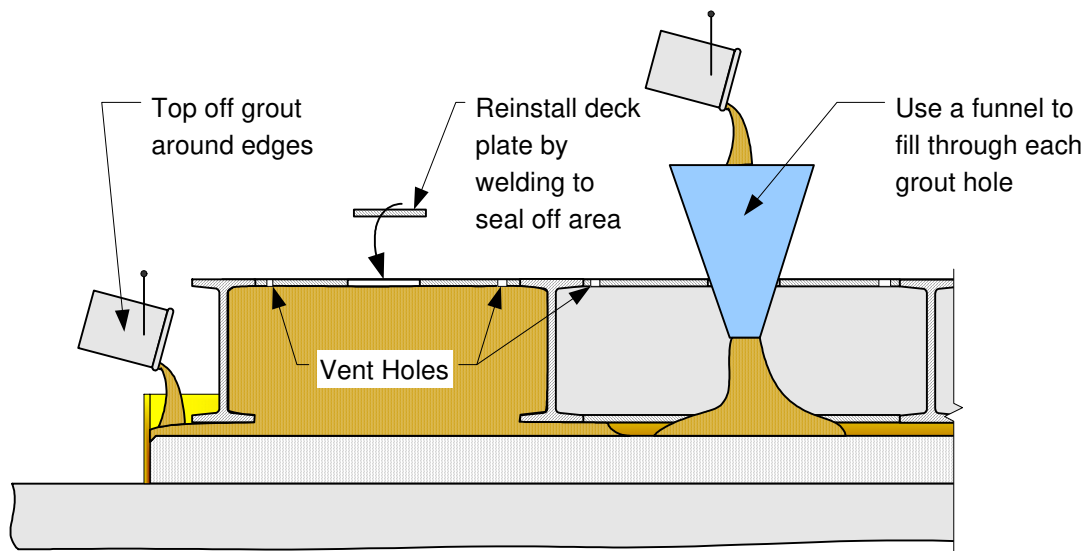
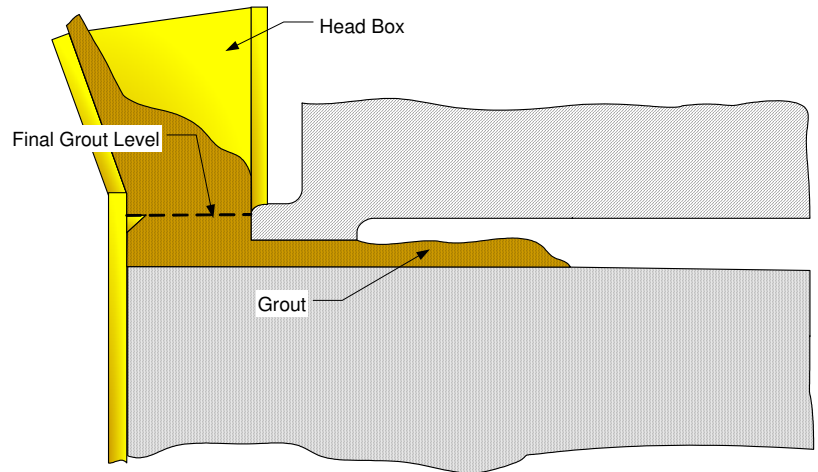

A typical I-Beam skid for heavy compressor equipment. Hand holes and vent holes should be strategically located between stages, etc., to facilitate grout placement under center longitudinal & transverse beams.

Expansion Joints

When expansion joints are required, the following procedures are suggested:

- Expansion joints are normally placed in the non-load bearing shoulders. The expansion joint should be 1/2" to 1" thick. It is very important that the expansion joint material bonds to the grout so that it does not provide a path to the concrete for oil, water and other contaminants. In deeper pours closed cell foam can be bonded to thin wooden bracing material and tacked into the base of the form. The top of the foam expansion joint should be level with the finished surface of the grout. Care should be taken that this foam type expansion joint is not moved out of place during the pouring of the grout

2. Another procedure for placing expansion joints: a polyurethane foam strip or a waxed or polyethylene wrapped plywood form is fit firmly in place at pre-selected expansion joint locations. After the epoxy grout cures the foam strip or plywood Form can be removed. The gaps then may be filled with ITW Expansion Joint Compound. This will prevent oil penetration to the concrete. It is suggested that expansion joints be placed so that they isolate each soleplate or rail. In full bed applications, expansion joints should be placed every 4-6 Feet.

Reinforcing Bars

Steel reinforcing bars, known as rebar, are a familiar feature of concrete structures. They are used to improve the tensile and shear strength of the structure. The coefficients of linear thermal expansion of steel and concrete are similar and compatible, but epoxy resin products have a coefficient two to five times as great and this can cause stress to build up inside the grout which can lead to cracking.

The tensile strength of epoxy grout is at least six times that of concrete, the shear strength at least five times, so horizontal rebar is not as important as it is with concrete. In fact, the use of horizontal rebar is NOT recommended when using epoxy grouts.

Where significant unloaded areas of ESCOWELD 7505E/7530, CHOCKFAST Red or CHOCKFAST Blue will occur it is advisable to tie them to the concrete with short vertical pieces of rebar or "All-Thread" rod. **This should always be done on new concrete**, at corners and edges in general and prevents tensile failure of the concrete. Where possible the dowels should be arranged as follows: 12" apart; 3" in from the edge of foundation and not closer than 1" from the top surface of the epoxy grout.

Grout Mixing

1. Instructions on the ESCOWELD packaging labels relating to safety precautions in handling ESCOWELD 7505E/7530 material components should be closely followed.
2. Each unit consists of:
 - One pail containing 25.5 lb. (11.5 kg) of resin (Part A) in lower compartment and 10.2 lb. (4.55 kg) of converter (Part B) in top tray.
 - ESCOWELD® 7530 Aggregate (Part C): Five - 53 lb. bags
3. Always mix complete units. Do not vary the ratio of resin and converter or add solvent or water to change the consistency.
4. Pour the entire contents of ESCOWELD Part B Converter into Part A Epoxy Resins container. Mix thoroughly with a power drill at approximately 200-250 RPM using a Jiffy-type mixing blade. Mixing should be completed in 3 minutes. The net weight of the combined Part A and Part B is 35.7 lb. (16.2 kg). Over mixing or violent agitation will result in excessive air entrapment and should be avoided.
5. ESCOWELD 7505E/7530 Epoxy Grout is mixed using a motorized mortar mixer. Pour the mixture of resin and converter into the mortar mixer then blend the aggregate in slowly until the recommended aggregate ratio has been added. When using a mortar mixer, the maximum mixer blade speed should not exceed 15 RPM. Mix the grout only long enough to uniformly wet all the aggregate particles. Do not over-mix.
6. The first mixing batch will be stiffer in consistency due to some of the liquid wetting the sides of the mixer and blades. Withholding one-half bag of ESCOWELD® 7530 Aggregate from the First batch will compensate for loss of the liquid.
7. Working life of ESCOWELD 7505E/7530 Epoxy Grout

ESCOWELD 7505E/7530 Epoxy Grout will exhibit the following approximate working time:

<u>Temperature °F</u>	<u>Working Time - Minutes</u>
90	50
77	120
60	150

Grout Placement

1. Cold Weather Considerations
 - a. Storage Conditions - All ESCOWELD 7505E/7530 Epoxy Grout components should be stored at a temperature between 70°F-80°F. Since aggregate is the major component portion of the mix; its temperature will be the most critical in determining the final mix temperature.
 - b. Surface Conditions - All surfaces that will come into contact with the grout should be maintained at a temperature of at least 50°F for 48 hours prior to and at least 48 hours after grouting
 - c. Curing Conditions - For best results, fabricate temporary shelter around the equipment to be grouted and pre-condition the equipment and foundation. Typical materials for this shelter are canvas or polyethylene. Use conventional heating equipment and be careful not to overheat localized areas.
2. Hot Weather Considerations
 - a. Storage Conditions - All ESCOWELDC 7505E/7530 Epoxy Grout components should be stored at temperatures between 70°F-80°F. Since aggregate is the major component portion of the mix, its temperature will be the most critical in determining the final mix temperature.
 - b. Surface Conditions - Shading or other cooling methods such as fans should be used to cool the concrete and steel to below 90°F.
 - c. Curing Conditions - Concrete and the equipment should be shaded 48 hours prior to grouting and 48 hours after placement of grout. It is suggested to proceed with the grouting operation in the early morning or at night after the equipment and foundation temperature drops. This allows heat development to take place during the coolest part of the day or evening.
3. Placing ESCOWELD 7505E/7530 Epoxy Grout
 - a. Prior to the grouting operation, the work area adjacent to the equipment to be grouted should be protected to facilitate clean-up after pouring is completed.
 - b. Proceed with grouting within a few hours after machinery leveling and alignment because castings have a tendency to creep or sag over a period of time when supported only by jack bolts. If a day or more elapses after leveling and alignment, re-check to confirm before grouting.
 - c. Grout placement should proceed in a manner that will assure the filling of all spaces and complete contact of grout with the surface to be grouted. ESCOWELD 7505E/7530 Epoxy Grout should be poured starting at one end of the equipment and working toward the other end to prevent air pockets and voids.
 - d. ESCOWELD~ 7505E/7530 Epoxy Grout has excellent placement consistency, but flow is enhanced using hydraulic head pressure. Construct a head box or funnel 1-2 feet deep to place the grout in these hard to reach places. Never allow the level of grout to fall beneath that of the baseplate because this will result in trapped air and voids. Do not vibrate as this will induce excessive air entrapment and result in a poor bearing area upon curing.
 - e. Forms must be constantly checked for leaks. All leaks must be sealed immediately or voids will develop. Putty or duct sealing materials should be available to repair leaks.
 - f. A smooth finish can be obtained by troweling the surface of ESCOWELD 7505E/7530 Epoxy Grout with a trowel wetted with IMPAX IXT-59 immediately after completing the pour. Care should be exercised to prevent blending solvent into the surface of the grout. This can result in a soft surface, which may take several days to harden.
 - g. Upon completion of the grouting operation, all tools and mixing equipment should be immediately cleaned using water or IMPAX IXT-59 Clean-up Solvent.

Grout Curing

The following is a cure chart which can be used as a guide for determining final cure times. The temperatures shown are of the baseplate and foundation, not ambient temperatures.

<u>Temperature - °F</u>	<u>Cure Time - Hours</u>
90	12
80	24
70	36

Reference

For details on the ESCOWELD 7505E/7530 Epoxy Grout, please request Bulletin No. 1612 or contact ITW Polymer Technologies' Engineering Services Department.

Date 02/2011

General: Every reasonable effort is made to insure the technical information and recommendations on these data pages are true and accurate to the best of our knowledge at the date of issuance. However, this information is subject to change without notice. Prior versions of this publication are invalid with the release of this version. Products and information are intended for use by qualified applicators that have the required background, technical knowledge, and equipment to perform said tasks in a satisfactory manner. Consult your local distributor for product availability, additional product information, and technical support.

Warranty: ITW Polymer Technologies, a division of Illinois Tool Works Inc., warrants that its products meet their printed specifications. This is the sole warranty. This warranty expires one year after product shipment.

Warranty Claims: If any product fails to meet the above, ITW Polymer Technologies will, at its option, either replace the product or refund the purchase price. ITW Polymer Technologies will have no other liability for breach of warranty, negligence, or otherwise. All warranty claims must be made in writing within one year of the date of shipment. No other claims will be considered.

Disclaimer: ITW Polymer Technologies makes no other warranty, expressed or implied, and specifically disclaims any warranty of merchantability or fitness for a particular purpose.

Suggestions concerning the use of products are not warranties. The purchaser assumes the responsibility for determining suitability of products and appropriate use. ITW Polymer Technologies' sole liability for breach of warranty, negligence or otherwise, shall be the replacement of product or refund of the purchase price, at ITW Polymer Technologies' election. Under no circumstances shall ITW Polymer Technologies be liable for any indirect, incidental or consequential damages.

Modification of Warranty: No distributor or sales representative has the authority to change the above provisions. No change in the above provisions will be valid unless in writing and signed by an officer or the Technical Director of ITW Polymer Technologies. No term of any purchase order shall serve to modify any provision of this document.

Mediation and Arbitration: If any dispute arises relating to products or product warranties, either the purchaser or ITW Polymer Technologies may a) initiate mediation under the then current Center for Public Resources (CPR) Model Procedure for Mediation of Business Disputes, or b) initiate a non-binding arbitration under the rules of the American Arbitration Association for the resolution of commercial disputes.