



TPO Design Guide

UltraPly™ TPO

UltraPly™ TPO XR

UltraPly™ Platinum™ TPO

ReflexEON™ TPO

ReflexEON™ Platinum™ TPO

June, 2011

Firestone Building Products Company, LLC

Sales: 800-428-4442

Technical: 800-428-4511

www.firestonebpco.com

Contents

1.01	General Design Criteria	6
	A. Applicability	6
	B. Consultation	8
	C. Design	8
	D. Warranty Requirements	9
	E. Warranty.....	9
1.02	Quality Assurance	10
	A. Job Site Considerations	10
	B. Asphalt Products	11
	C. Phased Construction / Temporary Roofing	11
	D. Insulation Stops and Back-nailing Nailing Strips:	15
	E. Back-nailing Modified Asphalt Base Sheets	16
	F. Back-nailing Type IV (4) and Type VI (6) Fiberglass Roofing Plies.....	17
	G. Cap Nails.....	18
1.03	Substrate and Substrate Requirements.....	18
	A. General	18
	B. Fastener Pullout Requirements.....	18
	C. Moisture Considerations.....	19
	D. Drainage and Slope	19
	E. Wood Nailers.....	20
	F. Expansion Joints	21
1.04	Fasteners	21
	A. General	21
1.05	Decks	25
	A. Platinum Retrofit or Re-cover Applications:.....	25
	B. General	26
	C. Classification.....	26
	D. Steel Deck.....	26
	E. Structural Concrete Roof Decks.....	27
	G. Cementitious Wood Fiber Decks	30
	H. Gypsum Roof Decks	30
	I. Lightweight Insulating Concrete Roof Decks.....	31
	J. Special Considerations for Partial Tear Off, and Retrofit/Recover Applications.....	32
	K. Partial Tear Off.....	33
	L. Retrofit / Recover Applications.....	33
	M. Existing Gravel, Smooth, and Granule Surfaced Asphalt Membranes	34
1.06	Base Sheet.....	35
1.07	Insulation	36
	A. General	36

	B. Attachment	36
	C. Multiple Layers of Insulation	37
	D. Mechanical Attachment of Insulation and Cover Board to Approved Substrates ..	38
	E. Minimum Number of Fasteners and Plates Per Insulation Board	40
	F. Asphalt Attachment of Insulation /Cover Board to Substrate.....	41
	G. Adhesive Attachment of Insulation /Cover Board to Substrate.....	42
1.08	Roof Membrane.....	46
	A. Membrane Securement Options For Single-Ply Membrane Systems	46
	B. Adhered Systems.....	47
	C. Ballasted Systems.....	47
	D. Mechanically Attached Systems.....	49
	E. Membrane Lap Splicing (ReflexEON & UltraPly TPO Membrane up to 30-year Warranty).....	50
1.09	Flashings	51
	A. Design considerations	51
	B. Wall/Curb Flashing Materials and Requirements	51
	C. Penetrations (Pipes, Conduits, Etc.)	53
	D. Penetration Pockets:	53
	E. Curbs and Terminations:.....	53
	F. Sheet Metal Work.....	53
1.10	Walkways	54
	A. Locations.....	54
	B. Walkway Material	54
1.11	Warranty	55
	A. General	55

List of Tables

1.01-1	Roofing System Capability.....	7
1.03-1	Backnailing Requirements for Sloped Roof.....	15
1.04-1	Minimum Fastener Pullout Resistances for Specific Systems.....	18
1.04-2	Recommended Number of Pull Out Tests.....	19
1.05-1	Allowable Fastener and Substrate Configurations.....	22
1.05-2	Acceptable Fastener Uses.....	23
1.05-3	Acceptable Fastener Plate Uses.....	24
1.05-4	Acceptable Batten Bar and Term Bar Uses.....	25
1.06-1	Structural Deck Classification.....	27
1.06-2	Acceptable Fasteners for Insulation on Steel Decks.....	27
1.06-3	Acceptable Insulations Adhesives for Insulation Attachment to Steel Decks.....	27
1.06-4	Single-Ply Adhesion/Attachment to Structural Concrete Roof Decks.....	28
1.06-5	Acceptable Fasteners for Concrete Roof Decks.....	29
1.06-6	Acceptable Insulation Adhesives for Insulation Attachment to Structural Concrete Roof Decks.....	29
1.06-7	Single-Ply Adhesion/Attachment to Wood Roof Decks.....	29
1.06-8	Acceptable Fasteners for Plywood and OSB Roof Decks.....	30
1.06-9	Acceptable Insulation Adhesives for Insulation Attachment to Plywood and OSB Roof Decks.....	30
1.06-10	Acceptable Fasteners for Cementitious Wood Fiber Roof Decks.....	30
1.06-11	Acceptable Insulation Adhesives for Insulation Attachment to Cementitious Wood Fiber Roof Decks.....	30
1.06-12	Acceptable Fasteners for Gypsum Roof Decks.....	30
1.06-13	Acceptable Insulation Adhesives for Insulation Attachment to Gypsum Roof Decks.....	31
1.06-14	Single-Ply Adhesion/Attachment to Lightweight Insulating Concrete Roof Decks.....	31
1.06-15	Acceptable Fasteners for Lightweight Insulating Concrete Roof Decks.....	31
1.06-16	Special Considerations for Partial Tear-Off and Retrofit/Recover Applications.....	32
1.07-1	Allowable Base Sheet Attachments.....	35
1.08-1	Insulation/Cover Board Attachment Options by Deck and Recover/Retrofit.....	37
1.08-2	Insulation/Cover Board Attachment to Insulation Options by Insulation Type.....	38
1.08-3	Insulation Attachment Options (Mechanical Attachment).....	39
1.08-4	Minimum Number of Fasteners and Plates per Insulation Board (MA).....	40
1.08-5	Minimum Number of Fasteners and Plates per Insulation Board (FA).....	41
1.08-6	Minimum Fastener Pullout Resistances for Specific Systems.....	41
1.08-7	Approved Substrates for Use with Asphalt Attachment of Insulation/Cover Board.....	42
1.08-8	Allowable Adhesive Attachment of Insulation/Cover Board to Structural Deck.....	43
1.08-9	Allowable Adhesive Attachment of Insulation/Cover Board to Base Insulation Layer.....	43
1.08-10	Allowable Adhesive Attachment of Insulation/Cover Board to Retrofit/Recover.....	44

1.09-1	Approved Immediate Insulation Substrates for Single-Ply Membranes Up to and Including 25-Year Warranties.....	47
1.09-2	Approved Immediate Deck Substrates for Single-Ply Membranes Up to and Including 20-Year Warranties.....	47
1.09-3	Approved Immediate Substrates for Single-Ply Membranes Up to and Including 15-Year Warranties.....	48
1.09-4	Adhesives for Single-Ply Membranes to Approved Substrates.....	48
1.09-5	Minimum Coverage Requirements for Various Ballast Gradations.....	49
1.09-6	Fastening Rates.....	50
1.10-1	Wall/Curb Flashing Materials and Requirements.....	53
1.12-1	Maximum Warranty Term Thermoplastic Systems.....	56
1.12-2	Acceptable Insulations (Immediate Substrate) for Single-Ply Membranes.....	57
1.12-3	Acceptable Insulations for Single-Ply Membranes: 20 or 25-yr Warranties.....	58
1.12-4	.080" ReflexEON Platinum & UltraPly Platinum System Design Options & Requirements.....	58
1.12-5	Wall/Curb Flashing Materials and Requirements.....	59
1.12-6	Firestone Thermoplastic Warranty Summary.....	59

1.01 General Design Criteria

A. Applicability

1. Parameters of this manual outline the **minimum** requirements for a Firestone Warranty. Local code and insurance requirements may require specific enhancements.
2. Warranties beyond 10 and up to 25-years may have specific system enhancements, some of which can be found in this manual. Contact your Firestone Building Products Technical Coordinator at 1-800-428-4522 for additional information.
3. For 30-year EPDM warranties, see the ReflexEON Platinum and UltraPly Platinum .080" membrane information.
4. For any warrantable UltraPly TPO roof system, the UltraBlend option for wall flashings may be used. UltraBlend refers to a roof system whereby TPO membrane is used in the field of the roof but RubberGard EPDM or EcoWhite EPDM wall and QuickSeam flashing accessories are used at vertical surfaces and at roof penetrations, curbs etc.
5. Statements in this design guide are provided in good faith with the expectation that a design professional be consulted prior to any job decisions being made.
6. Firestone roof systems may or may not be applicable, without special consideration, if subject to local, regional, or national building code requirements or testing agency restrictions.
 - a) It is the building owner's or the design professional's responsibility to consult with the controlling code agency official(s) to determine the specific requirements of each project and each system.
 - b) The Firestone Technical Coordinator should be contacted when local codes are in conflict with Firestone recommendations. Contacts: 800.428.4511.



Certain situations may arise where Firestone specifications and/or roofing requirements cannot be applied. It may not be possible for Firestone to issue the desired warranty for projects that deviate from current Firestone requirements and standards, unless a written deviation request for approval has been received, reviewed and approved by the Firestone Technical Coordinator prior to application of the proposed system.

7. The following conditions require special consideration and may not be warrantable. Contact your Firestone Building Products Technical Coordinator if any of the following conditions are present:
 - Roofs that exceed the maximum slope and height limits for the particular roof system assembly, see table 1.01-1
 - Projects that require special wind coverage, greater than 55 mph
 - Roofs located where localized wind phenomenon may occur, reference ASCE-7 wind maps
 - Roofs located in downslope, foothills of mountain ranges or escarpments
 - Mechanically attached systems located within 5 miles (8.3 Km) of the ocean coastline or within 1,500 feet (457 m) of a Great Lake shoreline
 - Geographical areas susceptible to hurricanes
 - Roofs subject to chemical or process byproduct discharge
 - Roofs with non-linear slopes such as arches, domes barrels, etc.
 - Buildings with large openings in a wall (greater than 10% of the any one wall surface) that could be left open in a storm
 - Roofs subject to heavy or repeated traffic in an area
 - Roofs subject to positive pressure situations such as: pressurized buildings, air infiltrating decks, canopies, overhangs, airplane hangars, distribution centers, etc
 - Buildings with high interior humidity such as swimming pools
 - Roof decks that do not provide adequate fastener pullout resistance



Unlimited slope in the chart below only refers to the potential maximum installation slope. When using a mechanical hot air welder there are practical limitations to the slope that can be done. Safety is the first order to consider when doing any job. Consult with the equipment manufacturer on the performance of the individual machine.

8. Cold storage and freezer facilities constitute a special condition. A designer familiar with cold storage

construction and vapor migration should be consulted in the design of the roof system and integration with the rest of the structure envelope.

**TABLE 1.01-1
ROOFING SYSTEM CAPABILITY**

	System	Product	Slope	Barrel, Arch, etc.	Maximum Height	Maximum Warranty Term	
Platinum ReflexEON and UltraPly TPO	Adhered (single or Wide Weld)	.080" ReflexEON & UltraPly TPO (8' or 10' sheet only)	Unlimited	OK	250' (76.2 m)	30-Year	
	Mechanically Attached (Wide Weld)	.080" ReflexEON & UltraPly TPO (8'sheet only)	Max. 4:12 (33.3%)	OK	120' (36.6 m)	30-Year	
ReflexEON & UltraPly TPO & UltraPly TPO XR	Adhered (single or Wide Weld)	.060" ReflexEON & UltraPly TPO (8' or 10' sheet only)	Unlimited	OK	250' (76.2 m)	25-Year	
		.060" ReflexEON & UltraPly TPO (8',10', or 12' sheet)	Unlimited	OK	250' (76.2 m)	20-Year	
		.045" UltraPly TPO (8',10', or 12' sheet)	Unlimited	OK	250' (76.2 m)	20-Year	
		UltraPly TPO XR 100 (.045")	XR Bonding Adhesive I.S.O. Spray S XR Stick	Unlimited	OK	250' (76.2 m)	15-Year
			Asphalt	Max. 4:12 (33.3%)	OK		
		UltraPly TPO XR 115 (.060")	XR Bonding Adhesive I.S.O. Spray S XR Stick	Unlimited	OK	250' (76.2 m)	20-Year
	Asphalt		Max. 4:12 (33.3%)	OK			
	Ballasted	Pavers	.060" UltraPly TPO	Max. 2:12 (16.6%)	NO	250 (76.2m)	20-Year
			.045" UltraPly TPO	Max. 2:12 (16.6%)	NO	250 (76.2m)	15-Year
		Stone	.060" UltraPly TPO	Max. 2:12 (16.6%)	NO	75' (22.8 m)	20-Year
			.045" UltraPly TPO	Max. 2:12 (16.6%)	NO	75' (22.8 m)	15-Year
	Mechanically Attached (Single or Wide Weld)	.060" ReflexEON & UltraPly TPO (8' or 10' sheet only)	Max. 4:12 (33.3%)	OK	120' (36.6 m)	25-Year	
		.060" ReflexEON & UltraPly TPO (8',10', or 12' sheet)	Max. 4:12 (33.3%)	OK	120' (36.6 m)	20-Year	
		.045" UltraPly TPO (8',10', or 12' sheet)	Max. 4:12 (33.3%)	OK	120' (36.6 m)	20-Year	
		UltraPly TPO XR 115 (.060")	Max. 4:12 (33.3%)	OK	120' (36.6 m)	20-Year	
		UltraPly TPO XR 100 (.045")	Max. 4:12 (33.3%)	OK	120' (36.6 m)	15-Year	
	InvisiWeld™ Plate	.045" UltraPly TPO (8',10', or 12' sheet)	Max. 4:12 (33.3%)	OK	120' (36.6 m)	15 - Year	

	Induction Bonded System	.060" ReflexEON & UltraPly TPO (8' or 10' sheet only)	Max. 4:12 (33.3%)	OK	120' (36.6 m)	20-Year
		.080" ReflexEON & UltraPly TPO (8' or 10' sheet only)	Max. 4:12 (33.3%)	OK	120' (36.6 m)	20 - Year
UltraPly TPO SA	Self Adhered TPO Membrane	060" UltraPly TPO SA	Max. 4:12 (33.3%)	OK	250 (76.2m)	20-Year
		045" UltraPly TPO SA	Max. 4:12 (33.3%)	OK	250 (76.2m)	15-Year
<u>Vegetative (Green) Roofing</u>		<u>SEE FIRESTONE BUILDING PRODUCTS SKYSCAPE™ VEGETATIVE ROOF SYSTEM DESIGN & APPLICATION GUIDE</u>				

B. Consultation

1. Firestone recommends that a design professional be involved in the design process. For additional assistance, your Firestone Technical Coordinator is available for consultation with respect to any necessary deviations from current Firestone requirements and standards.
2. For recommendations on any specific project, about the applicability, or appropriateness, of any material's suitability for use or use of products in conjunction with any other specific material, follow these steps:
 - a) Consult the Firestone Building Products Website: www.firestonebpc.com.
 - b) Consult this manual, the applicable Firestone UltraPly TPO Application Guide and the specific Technical Information Sheets (T.I.S.).
 - c) Consult with the building owner or building design professional.
 - d) Consult with your Firestone Building Products' Technical Coordinator at 1-800-428-4511.
3. Statements in this design guide are provided in good faith with the expectation that a design professional be consulted prior to any job decisions being made.

C. Design

1. Firestone does not perform engineering or design functions and does not approve or make comments regarding them.
2. Firestone recommends that a design professional be consulted to assure proper design, (i.e., roof system selection) installation, and conformance to building codes, insurance requirements, etc.
3. Refer to the Attachment Guide of this manual for specific membrane attachment requirements for mechanically attaching insulations and membranes.



The following are just a few of the conditions, which may influence the need for a design professional:

- Structural conditions that might not be sufficient to support the anticipated load of the completed roof installation
- Support the dynamic loading of the roof system
- The need to review the proposed system assembly for its applicability on specific projects
- The requirements of local building codes for the need of a thermal barrier
- The requirements of local building codes for the need of a vapor retarder
- The requirements of local building codes for the need of an air barrier
- When considering the effect of loads on the structure/decking due to the loading/staging of materials as a part of system installation. The design professional should specify the load limitations to be observed by the Firestone licensed applicator

D. Warranty Requirements

1. Where a Firestone Red Shield/RubberGard MAX/Red Shield Medallion labor and material warranty is required:
 - a) Submit a Pre-Installation Notice (PIN) along with an approved roof drawing, at least 14 days prior to project start. The PIN will be reviewed online by your Technical Coordinator. Following their review, you will receive an acknowledgement either of *Acceptance* or of a request for *Additional Information* and changes necessary to meet Firestone warranty requirements.
 - b) The roof must be installed according to the current Firestone requirements appropriate to the project conditions and design requirements, as posted on the **Firestone Technical Database**.
 - c) The Firestone roof system must be installed by a current Firestone Red Shield licensed applicator.
 - d) The Firestone roof system must be inspected by a Quality Building Services (QBS) Technical Representative.
 - e) Upon inspection and acceptance of the installed roof system by a QBS Technical Representative, the warranty will be issued and dated based on the completion date of the roof by the roofing contractor.
2. The Firestone/QBS inspection is to confirm the installation details of the roofing system for compliance with Firestone documents of record for warranty requirements. The inspection is not intended as an inspection for benefit of the building owner or the design professional with respect to contract, building codes or compliance with specifications other than those of Firestone.



A Firestone warranty cannot be issued if any of the following conditions exist:

- Non-roofing applications such as plaza deck construction, waterproofing, pond liners, etc.
- Roofing applications for single-family residences
- Other non-approved applications



Certain situations may arise where Firestone specifications and/or roofing requirements cannot be applied. It may not be possible for Firestone to issue the desired warranty for projects that deviate from current Firestone requirements and standards, unless a written request for approval has been received, reviewed and approved by your Firestone Technical Coordinator prior to application of the proposed system.

E. Warranty

1. Where a Firestone Red Shield labor and material warranty is required:
 - a) Submit an Electronic Pre-Installation Notice (P.I.N.) along with an approved roof drawing, 14 days prior to project start and receive an acknowledgement of acceptance or required enhancements to meet Firestone requirements to receive a warranty.
 - b) The roof must be installed according to the current Firestone requirements appropriate to the project conditions and design requirements.
 - c) The Firestone roof system must be installed by a current Firestone Red Shield licensed applicator.
 - d) The Firestone roof system must be inspected by a Firestone Technical Representative.
 - e) Upon inspection and acceptance of the installed roof system by a Firestone Technical Representative, the warranty will be issued and dated based on the completion date of the roof by the roofing contractor.
2. Firestone's inspection is to confirm the installation details of the roofing system for compliance with Firestone's documents of record for warranty requirements. The inspection is not intended as an inspection for benefit of the building owner or the design professional with respect to contract, building codes or compliance with specifications other than Firestone's.
3. At a minimum, the ReflexEON or UltraPly Platinum roof system shall consist of a .080 inch (2.0 mm) ReflexEON or UltraPly Platinum membrane, fully adhered or Mechanically Attached over one of the following Firestone Insulations, which has been installed over an acceptable substrate in accordance with Firestone details:
 - HailGard™ Composite Board, min. 1.5" (38 mm)
 - DensDeck® Cover Board, min. 1/4" (6 mm)

- ISO 95+™ GL Polyiso Insulation, min. 1.0" (25.4 mm)
 - ISOGARD™ HD Cover Board, min. ½" (12.7 mm)
 - Resista™ Insulation, min. 1.0" (25.4 mm)
4. An air barrier is required for projects with large wall openings that are greater than 10% of the total wall area that can be left open in a storm. Criteria to be determined based upon Firestone's Review.



A Firestone warranty cannot be issued if any of the following conditions exist:

- Non-roofing applications such as plaza deck construction, waterproofing, pond liners, etc.
- Roofing applications for single-family residences
- Other non-approved applications



Certain situations may arise where Firestone specifications and/or roofing requirements cannot be applied. It may not be possible for Firestone to issue the desired warranty for projects that deviate from current Firestone requirements and standards, unless a written request for approval has been received, reviewed and approved by your Firestone Technical Coordinator prior to application of the proposed system.

Diagram 1.01.1
Typical Roof Assembly Layers

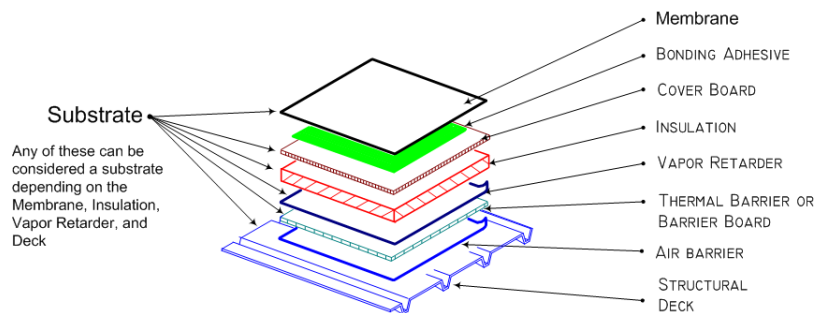

*Not all inter-layer attachment methods are shown for clarity.
See the [Firestone Glossary](#) for terms commonly used in this manual.*

1.02 Quality Assurance

A. Job Site Considerations

1. All safety regulations required by OSHA and other agencies having jurisdiction must be followed.
2. During the construction process, the roofing contractor is responsible for ensuring that all components of the Firestone roof system, including the finished areas are protected from damage, including, but not limited to:
 - Damage that may result from the continued construction process
 - Direct contact with continuous steam or heat sources when the in-service temperature is in excess of 160 °F (71.1 °C) for ReflexEON or UltraPly TPO products
 - Asphalt, coal tar, oil base or plastic roof cements, and re-saturated roof products, which are not to be used in direct contact with the waterproofing components of the Firestone UltraPly TPO membrane.
 - Discharges, such as petroleum products, greases, oils (mineral and vegetable), animal fats and other byproducts, which may come in contact with the membrane
3. Occupied Buildings: The contractor shall take precautions to prevent the spread of fumes, dust, and debris, where such material may enter into the building. The roofing contractor shall provide labor and materials to construct, maintain and remove, as necessary, temporary enclosures to prevent fumes, dust, and debris in the construction area(s) from entering the building
4. Cold weather application:

- a) When the outside temperature is below 40 °F (4.4 °C), installation of Firestone roof systems may require additional application precautions:
 - For a minimum of 24 hours before installation, adhesives and sealants should remain in an environment between 60 °F and 80 °F (15.5 °C and 26.6 °C).
 - Materials should be used within four hours of removal from a heated storage area. If materials are not used within that time period, they should be returned to the heated storage area until the temperature of the material returns to the temperature of the heated storage area. Typically, this is 24 hours.
- b) For additional information and guidelines, see the Firestone UltraPly TPO Application Guide and the NRCA Roofing and Waterproofing Manual.

B. Asphalt Products

1. See the Asphalt Design Guide and the Asphalt Application Guide for additional information.
2. Asphalt for insulation, roofing plies, or base sheets must be Firestone SEBS Mopping Asphalt or either ASTM D 312 Type III or Type IV. Asphalt selection must be suitable for the roof slope. All asphalt must be tested in accordance with ASTM D 312 and be certified by the supplier that it meets the minimum requirements for the specific type and application. Asphalt selection must be suitable for the roof slope.
3. Assure that all health and safety measures are followed when installing hot asphalt to protect the installers as well as occupants of the building. Assure compliance to all building codes and safety regulations when using hot asphalt.
4. Asphalt properties may change when stored at high temperatures and/or for long periods of time. Asphalt may become harder or may experience what is known as “fallback”. Fallback is the degradation of the asphalt to the point that its physical properties (i.e. softening point) deteriorate which could then cause roof slippage. To reduce the chances for fallback, the following recommendations should be implemented:
 - Use higher softening point asphalt
 - Decrease the kettle temperature as much as possible, while maintaining the minimum application temperature
 - Use material as quickly as possible, thus reducing exposure time
 - Insulate all lines and equipment used to transport asphalt
5. Asphalt primer: Asphalt primer must meet ASTM D-41.
6. Firestone does not manufacture or supply asphalt and does not warrant the performance of products we do not supply.

C. Phased Construction / Temporary Roofing

1. Phased Construction
 - a) Phased Construction is defined by the NRCA as “The installation of a roof system in two or more separate time intervals.” The need for temporary roofing is determined by the design professional.



Firestone does not recommend phased construction. Phased construction results in unprotected roof sections, which can allow moisture into the base plies or trap moisture, dust or debris between the plies of the roof system. These application defects may increase the incidence of blistering in the Firestone roof system.

- b) A better option than the use of phased construction would be the use of a temporary roof, which allows for the delayed installation of the roof system until more suitable weather, or until other trades can complete their projects. A temporary roof can be designed and installed in the same way as a vapor retarder, and can then become a vapor retarder.
2. Temporary Roofing
 - a) If installation of the roof system is required during unsuitable weather, or before completion of wood blocking, curbs, penetrations, or the erection of walls, a temporary roof may need to be installed.
 - b) If a temporary roof is needed due to construction requirements, Firestone recommends installing a modified asphalt base sheet or two fiberglass roofing plies in an appropriate adhesive over an approved substrate, to be used as the temporary roof. This temporary roof can serve to protect the interior of the building during the early stages of construction. It may then be removed or repaired, if necessary, and can

be left as a vapor retarder prior to the installation of the finished Firestone roofing system.

- c) If roof insulation is installed under the temporary roof, the insulation shall be inspected for wet or damaged areas, so that such areas may be removed and replaced prior to installation of the Firestone roof system.
- d) When a temporary roof is specified as a vapor retarder, precaution shall be exercised in protecting the temporary roof from other construction tradesmen. Damage to the temporary roof may impair its effectiveness as a vapor retarder. If the vapor retarder is installed as a temporary roof during construction, the vapor retarder shall be examined, and if necessary, repaired to ensure watertight integrity prior to installation of the remainder of the roof system.
- e) For additional information regarding temporary roofs, refer to the NRCA's Roofing and Waterproofing Manual or contact your Firestone Technical Coordinator.

1.03 Vapor Retarder / Air Barriers



The determination of the necessity and location for a vapor retarder or an air barrier are project specific requirements, which is the responsibility of the building owner or his design professional. The proper assessment of the building, the need for, and the proper design of, an air barrier and vapor retarder are critical to the long-term operation of the roofing system.



Firestone does not review or calculate dew point analyses and therefore, does not accept responsibility for damage due to recurrence rate or location of the dew point. Although not all projects require a vapor retarder, a design review should be considered for all projects.

The inclusion of an air barrier or vapor retarder may affect the Underwriter Laboratories or Factory Mutual rating of the roof system.

The inclusion of an air barrier or vapor retarder may affect the Firestone system requirements and consequently the Firestone warranty. Contact your Technical Coordinator at Firestone Building Products prior to application of the proposed system.

A. Vapor Retarder

1. To control moisture, a vapor retarder may be necessary to protect certain roofing components when high interior humidity is of concern. Some examples are:
 - High interior relative humidity is present.
 - When a vapor drive may be expected to form a dew point under the roof membrane or in the insulation. (Building usages with high humidity interiors where vapor drive may occur) such as swimming pools, laundry facilities, paper mills, and bottling plants.

In these types of environments, there is substantial upward vapor drive, and the potential exists for extreme amounts of moisture accumulation within the roof assembly. If an effective vapor retarder is not included at the proper location in the roof assembly, so that the retarder is warmer than the dew point, condensation will cause damage from the moisture retained in the roof assembly.

This movement is reversed in some air-conditioned buildings in humid summer conditions. This is especially true in southern states.

Vapor retarders are installed because water vapor causes several types of roof assembly failures such as:

- Reduced R-value, since wet insulation becomes a conductor of heat rather than an insulator.
- Deterioration of the roof membrane, insulation, structural decks, and associated building components.
- Delamination of roof components from trapped moisture, which freezes and thaws, eventually evaporating under solar heat with the resulting vapor pressure causing blisters and delamination of the roof assembly components.

The following is a partial listing which might influence the need for a vapor retarder:

- Building usage as related to vapor drive.
- External temperature in relation to internal temperature.

- The humidity of the interior and/or exterior air.
- Building code requirements.
- Construction moisture, particularly during winter when temporary propane heat is required.

A vapor retarder's effectiveness generally depends upon the following factors:

- The vapor retarder's perm (permeance) rating shall be as close to zero as possible.
- The adequacy design of the vapor retarder membrane.
- The integrity of the vapor retarder's seals at perimeters and penetrations.
- The integrity of the vapor retarder's membrane after other tradesmen finish their projects during construction or any subsequent roof or equipment alterations.
- The vapor retarder's location within the insulated roof assembly.

Construction roof traffic shall be restricted to prevent damage to the vapor retarder. In the event damage does occur, repair the vapor retarder damage with the same roof components and quantities as specified for the vapor retarder installation.

Contact one of the four generally accepted agencies for help in determining the need for a vapor retarder. They are:

[National Roofing Contractors Association \(NRCA\) guidelines](#)

[U. S. Army Corp of Engineering Cold Regions Research and Engineering Laboratory \(CRREL\) guidelines](#)

[American Society of Heating, Refrigerating and Air-Conditioning Engineers \(ASHRAE\)](#)

[Oak Ridge National Laboratory \(ORNL\)](#)

Vapor Retarder properties:

A vapor retarder is defined as a building envelope element that limits diffusion of moisture into an assembly. Diffusion is water vapor migration in a material. Its rate depends on two factors:

Water vapor pressure difference across the roof assembly

Resistance of materials along the migration path

Some materials have more resistance than others. Placing a high-resistance material in a roof assembly may help control moisture migration.

Vapor retarders are intended to limit moisture diffusion. Therefore, the main property requirement of a vapor retarder is low water vapor permeance. Water vapor permeance is defined as:

"The time of water vapor transmission through a unit area of flat materials or construction induced by a unit vapor pressure difference between two specified surfaces, under specified temperature and humidity conditions".

2. Vapor Retarder Design:

The roof system designer is generally responsible for the design requirements of the roof deck, vapor retarder, and rigid insulation along with the roof system. This is more important when specifying roof systems over high humidity buildings. The need for a vapor retarder, as well as the type, placement and location of a vapor retarder should be determined by a professional architect or engineer. The list below, are examples of common vapor retarder applications. If asphalt products are specified as a vapor retarder, consult the **Firestone Modified Bitumen Design Guide** and **APP, SBS, and BUR Application Guides** for complete information on the warrantable design and installation of asphalt products.

- Firestone V-Force vapor retarder (self-adhered), applied to a flat substrate that has been primed with V-Force Primer. See the V-Force and V-Force Primer Technical Information Sheets (TIS) on the Technical Database for application information.
- Firestone MB Base SA, with adhered laps, applied to a flat surface primed with Firestone SA Primer.
- Mopped Firestone Type IV (4) or VI (6) Ply Sheet over a nailed Firestone MB Base Sheet.
- Mechanically attached fiberglass or polyester venting base sheet with 18" (457 mm) side and end laps mopped with hot asphalt.
- Existing dry and sound uninsulated built-up roof system (all splits and blisters repaired).
- Mopped Firestone Type IV (4) or VI (6) Ply Sheet over an existing dry and sound uninsulated built-up roof system. If gravel surfaced, then gravel shall be removed by power brooming, vacuuming and spudding.
- 2 plies of mopped Firestone Type IV (4) or VI (6) Ply Sheet set in hot asphalt over an acceptable mechanically attached barrier board.
- 2 plies of mopped Firestone Type IV (4) or VI (6) Ply Sheet set in hot asphalt directly on a properly prepared structural concrete deck.
- Fully adhered Firestone SBS Base Sheet set in hot asphalt, cold adhesive, or SBS Torch Base heat fused, over an acceptable mechanically attached barrier board.

- Fully adhered Firestone SBS Base Sheet set in hot asphalt, cold adhesive, or SBS Torch Base heat fused, directly on a properly prepared structural concrete deck.
- Six (6) mil polyethylene sheeting taped at laps and to penetrations and perimeters.

The roof system designer must:

- Assure that the methods of attachment of the roof system to the vapor retarder selected are compatible
- Assure that the vapor retarder will extend continuously and evenly throughout the roof plane to provide
- complete seal against the intrusion of moist air from the building interior. Integration of the wall and roof
- air retarder systems is essential
- Consider the effect of construction moisture on a new roof system, particularly during winter, when
- temporary propane heat is required

B. Air Barriers

1. While some Firestone roof systems may require an air barrier to receive a Firestone warranty, the need for an air barrier, as well as the type, placement and location of the air barrier must be determined by a professional architect or engineer.

Air barriers systems are a component of building envelope systems that control the movement of air into and out of buildings.

An air barrier may consist of a single material or of two or more materials which, when installed as a system, make up an air impermeable, structurally adequate barrier.

Air barrier systems are generally comprised of building components and materials that have an air permeability not exceeding 0.004 cfm/sf under a pressure differential of .3 in water.

No single component or material has the capability to provide a complete air barrier system for a building; therefore, air barrier systems include many components and materials that are interfaced with each other. Firestone recommends that the individual manufacturers of these products provide written certification that their products, when used together, meet this requirement.

If the air barrier is to perform its intended role, it must meet a number of requirements:

- **Continuity:** The assembly must be linked together to ensure that there is no break in the air tightness of the envelope.
- **Structural Integrity:** The air barrier must be capable of resisting the imposed load or must be supported by one that can. It must be capable of resisting the strongest wind load acting as either a pressure or suction without rupturing or breaking away from its support. The air barrier and its support must be sufficiently rigid to resist displacement.
- **Air Impermeability:** A major requirement of an air barrier is that it offers a high resistance to airflow.
- **Durability:** Durability depends largely on how a material reacts to a specific environment such as moisture, temperature, ultra-violet radiation, and to the presence of other materials (incompatibility).

C. Sloped Roofs – Asphalt Vapor or Air Barrier Systems Attachment

1. The building owner or the design professional intending to specify back-nailing should consider geographic location, specific job conditions, accepted area application practices, and the type and grade of materials specified when creating an actual specification for a project. When the slope of the roof exceeds 1/2": 12" (4.2%), and hot asphalt attachment is specified, Firestone requires Firestone SBES Mopping Asphalt or Type IV (4) asphalt be used.

Contact your Firestone Technical Coordinator for additional requirements regarding roof slopes over 3": 12" (25%).

For roof slopes up to and including 1/2": 12" (4.2%), the side laps can be installed parallel or perpendicular to the slope.

For roofs slopes greater than 1/2": 12" (4.2%), the membrane must run parallel to the slope and be back-nailed as follows:

**TABLE 1.03-1
BACKNAILING REQUIREMENTS FOR SLOPED ROOFS**

Base Sheet	Attachment	<1/2" (4.2%)	>1/2" <1" (4.2% - 8.3%)	>1" <2" (8.3% -16.7%)	>2" <3" (16.7% - 25%)
Any Applicable Firestone Base Sheet	Hot Asphalt Or Mechanically Attached	NFR	Nailers 32' o.c.	Nailers 32' o.c.	Nailers 16' o.c.
			Full Length Sheet	Full Length Sheet	½ Length Sheet
Any Applicable Firestone Base Sheet	Heat Fused, Hot Asphalt, Mechanically Attached, or Firestone Multi Purpose MB Cold Adhesive	NFR	NFR	NFR	Nailers 32' o.c.
					Full Length Sheet
Any Applicable Firestone Base Sheet	Self Adhered, Heat Fused, Hot Asphalt, Mechanically Attached, or Firestone Multi Purpose MB Cold Adhesive	NFR	NFR	NFR	Nailers 32 o.c.
					Full Length Sheet
<i>Refer to Firestone MB-BN-1 for detailed back-nailing requirements.</i>					
<i>NFR – No Fastener Required at This Slope</i>					

D. Insulation Stops and Back-nailing Nailing Strips:

1. Back-nailing nailing strips are required on all roofs with slopes greater than 16.6% (2:12).
2. Insulation stops and are recommended on all roofs with slopes greater than 16.6% (2:12).
3. Back-nailing nailing strips and Insulation stops shall be a minimum of 3 1/2" (88.9 mm) wide and the same thickness as the roof insulation.
4. Back-nailing nailing strips and Insulation stops must be attached to resist a force of 200 lbf per lineal foot (2.9 kN/m) minimum.
5. Insulation stops and back-nailing nailing strips are not needed when system is applied directly to a wood deck or a similar nailable substrate.
6. Contact your Firestone Technical Coordinator for information regarding back-nailing requirements utilizing approved insulation less than 1 inch.

E. Back-nailing Modified Asphalt Base Sheets

1. Non-Nailable decks and nailable decks with insulation

Cut the sheet to conform to nailer spacing. Using capped nails, nail the end lap across the width of the sheet, with the first nail spaced 3/4" (19 mm) from the leading edge of the sheet. The remaining nails are to be spaced approximately 3" (76.2 mm) on center. The nails should be staggered across the width of the nailer.

Firestone fasteners and plates may be used in lieu of cap nails. Four per end lap are required.

2. Nailable decks with no insulation

Cut the sheet to conform to nailer spacing. Using capped nails or Firestone fasteners and plates, nail the end lap across the width of the sheet, with the first nail spaced 3/4" (19 mm) from the leading edge of the sheet. The remaining nails are to be spaced approximately 3" (76.2 mm) on center. The nails should be staggered across the width of the nailer.

Firestone fasteners and plates may be used in lieu of cap nails. Four per end lap are required.

3. Cap nails must have 1" (25.4 mm) diameter heads with steel head only. Shank must be minimum 11-gauge (2.3 mm) annular ring or spiral shank and be FM Approved.

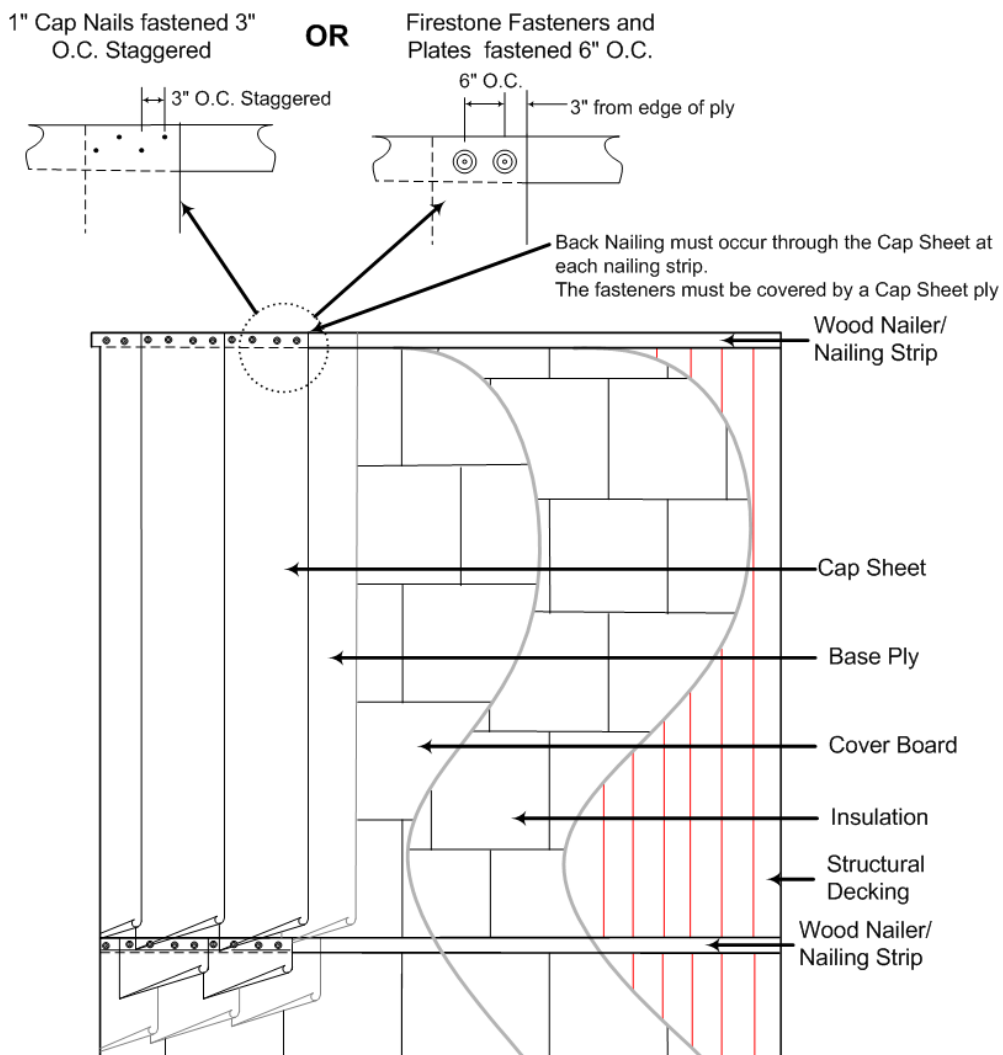

F. Back-nailing Type IV (4) and Type VI (6) Fiberglass Roofing Plies

1. Using capped nails or Firestone fasteners and plates, back-nail 3" (76.2 mm) o.c. from the back edge of each felt along the nailer ensuring that the nails are covered by a minimum of two plies of felt. The nails should be staggered across the width of the nailer.
2. Cap nails must be FM Approved, and have 1" (25.4 mm) diameter steel heads. Shank must be a minimum of 11-gauge (2.3 mm) annular ring or spiral.

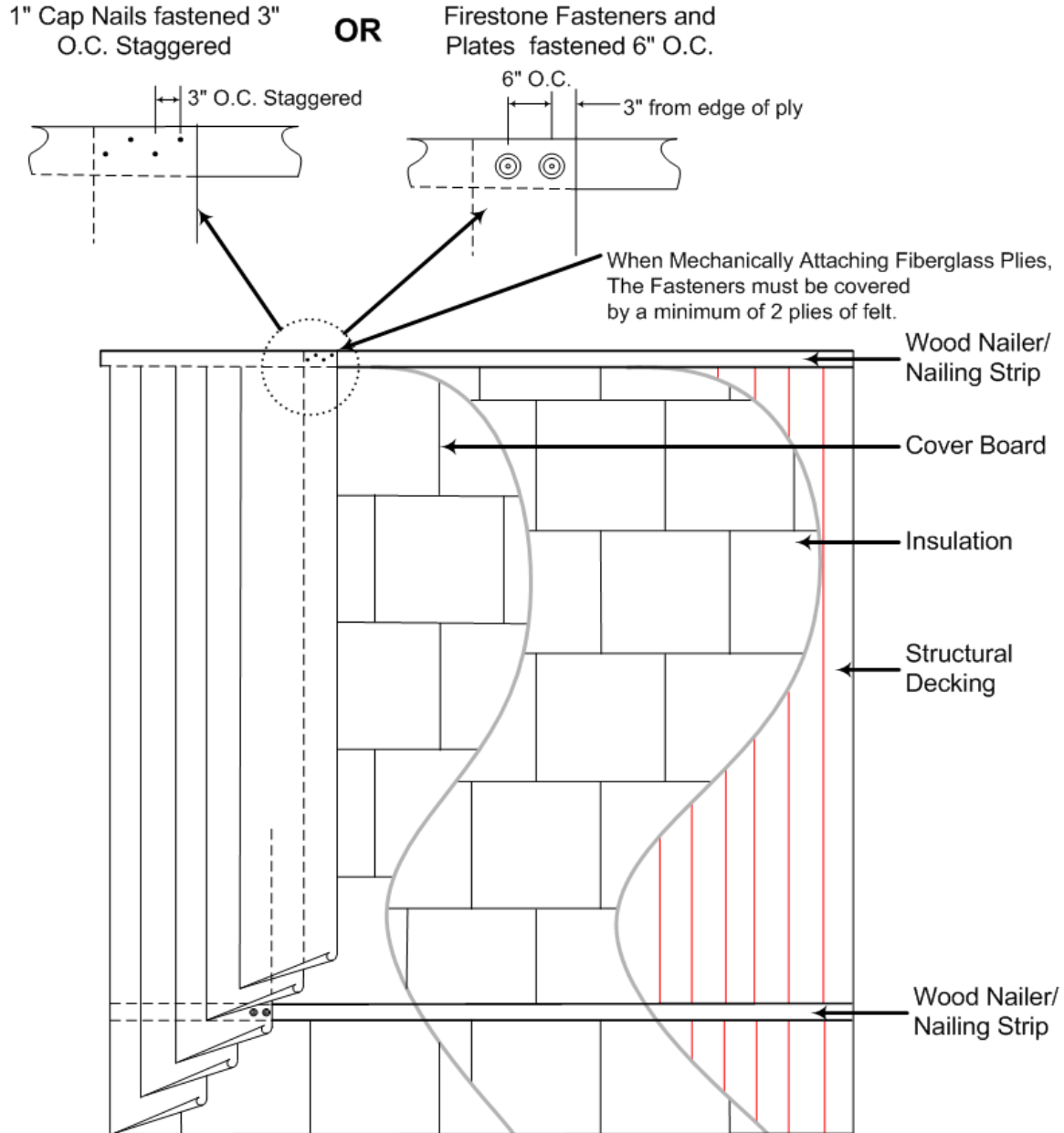

G. Cap Nails

1. Cap nails must be FM Approved, and have 1" (25.4 mm) diameter steel heads. Shank must be a minimum of 11-gauge (2.3 mm) annular ring or spiral.
2. Cap nails cannot be used to attach insulation or for 20 year systems.
3. Firestone insulation plates and fasteners may be used in lieu of cap nails.
 - a) It is the roof system designer's responsibility to:
 - Assure that the methods of attachment of the roof system to the vapor retarder selected are compatible.
 - Assure that the vapor retarder will extend continuously and evenly throughout the roof plane to provide a complete seal against the intrusion of moist air from the building interior. Integration of the wall and roof air retarder systems is essential.
 - Take the appropriate steps necessary to deal with the effect of construction moisture on a new roofing system, particularly during winter, when temporary propane heat is required.

1.03 Substrate and Substrate Requirements

A. General

1. The Firestone roof system depends on a suitable substrate to perform its intended function of weatherproofing the building.



It is the roofing contractor's responsibility for ensuring that the substrate is acceptable for the Firestone roof system.

2. The substrate to which the Firestone roof system is installed must:
 - Be structurally sound
 - Be dry, smooth, flat and clean
 - Be free of sharp fins, or foreign materials that could damage the membrane
 - Meet the minimum requirements for the system
3. When using asphalt to adhere insulation to a structural concrete substrate, the concrete must be primed with an ASTM D 41 asphalt primer. The primer is applied at a rate 1-1/2 to 2 gallons per 100 square feet (0.61 to 0.82 L/sq m).

B. Fastener Pullout Requirements

1. Substrates for membrane and or the insulation attachment are required to provide sufficient pullout resistance for the fasteners and the roof system.

TABLE 1.04-1

MINIMUM FASTENER PULLOUT RESISTANCES FOR SPECIFIC SYSTEMS

System	Minimum Fastener Pullout
Fully Adhered systems with Insulation Mechanically Attached to Deck	300 lb (136.1 kg)
Single-Ply mechanically attached.	400 lb (181.4 kg)
Base Sheet Mechanically Attached to Deck	300 lb (136.1 kg)
Base Sheet Nailed to Deck (Cap nail or LWC Fastener)	40 lb (18.1 kg)
Contact the Roof System Solutions Group at Firestone Building Products when the structural deck does not meet the minimum fastener pullout requirements.	

2. See the Firestone Attachment Guide for the minimum adhesive pull test requirements for insulation adhesives.
3. Pullout Tests: Due to the variety of physical conditions that can affect pullout resistance, Firestone recommends that on-site tests be conducted by an independent testing laboratory, the manufacturer's

representative or the roofing contractor, to determine actual pullout values. The following deck types are those which may not provide sufficient pullout resistance:

- Steel decks thinner than 22 gauge (0.76 mm)
 - Concrete less than 3000 psi (20,684 kPa)
 - Plywood or oriented strand board less than 7/16" (11.1 mm) thickness
 - Wood plank less than 3/4" (19mm) thickness
 - All poured or pre-cast gypsum, cementitious wood fiber and lightweight insulating concrete decks
 - Existing masonry or brick
 - Any other substrate that does not have a published pullout capacity greater than the minimum required for the applicable roof system
- a) The sections of the substrate where integrity is most in question should be used for testing. Test areas should include the corners, drain areas, and perimeters. The minimum number of pullout tests recommended is as follows:

TABLE 1.04 –2
RECOMMENDED NUMBER OF PULL OUT TESTS

ROOF SIZE		Number of Pull-Out Tests
Less Than 10,000 ft ²	Less Than 1,000 m ²	6
10,000 sf - 50,000 ft ²	1,000 m ² – 5,000 m ²	10
50,000 sf - 100,000 ft ²	5,000 m ² – 10,000 m ²	20
Over 100,000 ft ²	10,000 m ²	1 per 5,000 ft ² / 500 m ²

- b) When new construction or other conditions prevent preliminary on-site pullout tests, the fastener manufacturer should supply estimated pullout values for design and bid purposes. On-site verification of the pullout capacity must be confirmed prior to system installation. (Consider requesting a unit price bid for potential increased fastening requirement)

C. Moisture Considerations

1. The roofing contractor is responsible for ensuring that the substrate is suitable to receive a Firestone roof system. All damaged and/or wet insulation or substrate must be removed and replaced prior to the application of the Firestone roof system.
2. A moisture survey should be conducted to determine the moisture content of any existing roof system component. All damaged and/or wet components of the existing system that would be detrimental to the new Firestone roof system must be removed prior to its installation.
3. Failure to remove existing system components that cause damage to the new Firestone roofing system is not warrantable.
4. The best diagnostic technique is by taking and evaluating a series of roof cores.
5. Three techniques are currently available to evaluate the roof by indirect / non-invasive means. Results of these studies must still be correlated with roof cores. These techniques provide measurements of factors that can be associated with the presence of moisture:
 - Nuclear moisture detection
 - Infrared thermography
 - Electric capacitance

D. Drainage and Slope



Building codes may require a specific minimum slope for drainage. It is the building owner or his design professional's responsibility to consult with the controlling code agency official(s) to determine the specific requirements of each project and each system.

When interior drains are necessary, they must be installed at the low points of a sloped roof deck and maintained in a working condition.

1. The NRCA and prevailing building codes recommends that a minimum roof slope of ¼" (6.4 mm) per foot be obtained to facilitate proper drainage and maximize long-term performance of the roof system. Firestone recommends following the NRCA guidelines. The minimum Firestone requirement is POSITIVE drainage.
2. Ponding water is defined as a condition existing on any area of the roof where water remains more than forty-eight (48) hours after precipitation.
3. Adequacy of drainage provisions, placement, sizing and/or number of drains required is the responsibility of the building owner or his design professional. Drainage conditions should meet the requirements of applicable codes as well as standard industry recommendations.
4. In re-roofing or re-cover situations, analysis of the existing drainage conditions is the responsibility of the building owner or his design professional. Existing deck deflection or ponding water may necessitate upgrading of the drainage provisions, including relocation of existing drains, possible addition of new drains, increased bar joist support etc. Firestone does not design roof drainage systems or assume any liability for the adequacy (or lack of) roof drainage systems or facilities.
5. Proper and adequate drainage of the roof surface is required to assure the long-term performance of the roofing system. Drains should be of sufficient number, size, and located to provide satisfactory and rapid drainage of the entire roof surface (within 24 to 48 hours of precipitation). Although, a minimum roof slope of ¼" (6.4 mm) per foot is recommended, other slopes are acceptable to receive a Firestone warranty provided positive drainage is attained.
6. Tapered ISO 95+ GL provides an effective and economical solution where substrate slope will not permit efficient drainage. When properly installed, it can extend the life of the roof assembly by eliminating problems associated with ponding water. Tapered ISO 95+ GL is available in slopes from 1/16" to 1/2" per foot. Firestone provides a variety of technical support services for the installation of tapered insulation through the Firestone Tapered Engineering Design Department.
7. The following are just some of the reasons why proper roof drainage is important:
 - Standing water can result in deck deflection and possible structural damage
 - Water on the roof can promote vegetation, fungi and bacterial growth
 - In the event of an opening in the roof membrane, standing water can significantly worsen the damage to the roof system, the building itself, and the interior contents
 - It is required by many, if not all, building codes
 - Proper drainage of the roof system prevents premature deterioration of the roof membrane and roof components

E. Wood Nailers

1. For new construction projects, wood nailers must be kiln-dried (Southern Pine, Douglas Fir) structural grade #2 or better.
2. **Wood nailers by others:** Make these specifications and details available when others will install nailers. Work that compromises the integrity of the system may jeopardize the warranty.
3. For re-roof projects and new construction projects where a poured-in-place deck will be used, wood nailers must be pressure treated for rot resistance, #2 or better lumber. Asphaltic or creosote-treated lumber is not acceptable. Lumber treated with other wood preservatives such as Pentachlorophenol, Copper Naphthenate or Copper 8-quinolinolate will adversely affect the membrane when in direct contact and are, therefore, unacceptable.



Due to EPA regulations regarding treated wood, new treatments for lumber may be highly corrosive to fasteners. Contact the fastener manufacturer for their recommendations on fasteners if attaching nailers that have been treated with the more corrosive materials.

Chemical treating for fire resistance or other purposes (other than pressure treating for rot resistance, i.e., CCA, ACZA, CBA, ACQ or other copper treatments) may affect the performance of the Firestone membrane and accessories. Contact your Technical Coordinator at Firestone Building Products when using chemically treated lumber that will come in contact with the membrane.

4. Firestone requires Wood nailers the following locations:
 - All roof edges
 - Metal penetration pockets
 - The wood nailer may be deleted when metal flanges are less than 12" (304.8 mm) on a side

- Wood nailers must totally support all sheet metal flanges and be at least ½" (12.7 mm) wider to roof side
 - The wood nailer may be deleted when flanges are placed and secured directly to the deck
 - Refer to Firestone details for other location requirements
5. The wood nailer may be omitted when metal flanges are more than 12" (304.8 mm) on a side and when metal flanges are placed and secured directly to the deck.
 6. The building owner or his design professional must specify a wood nailer attachment system that will resist a minimum force of 200 lb per foot (2.9 N/m) in any direction. Firestone fasteners are required for all roofing applications. For further clarification, please refer to Factory Mutual Loss Prevention Data Sheet 1-49.



If forces at the building perimeters are greater than 200 lb per foot (2.9 N/m) due to increased wind speed as dictated by code requirements and calculated using either ASCE-7 or ANSI/SPRI ES-1, then the securement of the nailers must also be increased to accommodate the calculated loads.

F. Expansion Joints

1. The determination of the necessity and location for expansion joints is a project specific requirement, which is the responsibility of building owner or his design professional. Typical consideration for selection criteria may be one or more of the following:
 - Where expansion, contraction or deflection joints are provided in the building structural system
 - Roof expansion joints must be located to accommodate movements caused by building structural movement
 - Where structural framing elements such as joists, rafters, purlin, or steel decking change direction
 - Deck material changes (e.g., from steel to concrete deck). Where different types of roof decks such as concrete and steel abut each other
 - Where additions are connected to existing buildings
 - At junctions where interior heating conditions change such as a heated space abutting an unheated space
 - Where movement between vertical walls and the roof deck is anticipated
 - Roof areas greater than 200 feet (61 m) on any direction
 - Coordination and sequencing of expansion joint closure systems and their continuity, compatibility and function of seal is the responsibility of the design team

Note: The conditions above may not be inclusive. Other conditions may exist in which expansion joints should be considered.
2. Expansion joints must not restrict the flow of water.
3. Firestone expansion joint details for single-ply systems are located in the Details section of the Technical Database.

1.04 Fasteners

A. General

1. Refer to the Technical Information Sheet (T. I. S.) that references the specific fastener being used and for the deck penetration requirements of that fastener. All fasteners must be suitable for the existing deck type.
2. Roof systems rely on the attachment of the components to the deck substrate to perform its basic functions. Wind creates uplift forces on the roof; therefore, the overall holding power of the fasteners is critical. Firestone recommends that the use of any fastener be investigated should there be concerns about the structural integrity of the deck. Some of the items to be considered include:
 - How the fastener(s) might affect the deck
 - The capability of the deck to hold the fasteners and roof system in place in a wind related event



Firestone All Purpose (AP) fasteners are not acceptable for use with the Platinum EPDM roof system.

3. The structural integrity of the deck may have been weakened over time, thus the choice of fastener and roof attachment methods should be considered in determining the best solution to the given deck and situation.



Insulation fasteners / plates are not approved for use directly under a ballasted membrane system.

Firestone requires that a suitable insulation or cover board be installed over any substrate that would damage the membrane. This includes, but is not limited to:

- Fasteners / plates used for insulation attachment
- Fasteners / plates used for existing membrane securement
- Substrates that are not smooth, flat, clean, free of sharp fins, or foreign materials that could damage the membrane



For retrofit roof systems, Firestone Heavy Duty (HD) fasteners must be used for a 15-year or greater warranty, when mechanically fastening insulation using fasteners and plates.

For new and replacement roofing, Firestone HD fasteners must be used for a 20 or 25-year Red Shield warranty, when mechanically fastening insulation using fasteners and plates.

Firestone All Purpose (AP) fasteners are not acceptable for use with 15-year recover or any 20 or 25-year Red Shield warranty systems.

TABLE 1.05-1

ALLOWABLE FASTENER AND SUBSTRATE CONFIGURATIONS

Firestone Fastener		ADHERED MEMBRANE SYSTEMS	Mechanically Attached Membrane Systems		Acceptable for 20-year warranty	Steel Decks	Structural Concrete Decks	Plywood or OSB Decks	Cementitious Wood Fiber Decks	Gypsum Decks	Lightweight Insulating Concrete Decks	
T.I.S. Sheet No.	Fastener		Insulation Attachment	Insulation Attachment							Membrane Batten Strips or Seam Plates	Steel Pan
1001	All-Purpose Fastener	✓	✓	✓		✓		✓				
1002	Heavy-Duty Fastener	✓	✓	✓	✓	✓	✓	✓			✓	✓
1005	Concrete Drive Fastener	✓	✓	✓	✓		✓					✓
1006	Polymer Fastener	✓	✓	✓	✓				✓	✓		
1007	Firestone AccuTrac Kit	✓	✓			✓		✓				
1009	HD Plus Fastener	✓	✓	✓	✓	✓						
1011	Purlin Fastener			✓								
1012	LWC Base Ply Fastener				✓					✓	✓	✓
For the attachment of base sheets. Insulation may not be attached with LWC Base Ply Fastener												
1013	#12 Belted Fastener	✓	✓			✓		✓				
1014	#15 Belted Fastener	✓	✓		✓	✓		✓				
1015	Nail Driver							✓				
For the attachment of base sheets. Insulation may not be attached with nails of any kind												
1019	HailGard Fastener	✓	✓		✓	✓	✓	✓			✓	✓

✓ = Acceptable for use

**TABLE 1.05-2
ACCEPTABLE FASTENER USES**

Firestone Fastener		Platinum systems	For the attachment of:					
			Roofing insulation (in combination with Firestone Insulation Plate)	Base sheets (In combination with Firestone Insulation Plate)	Firestone Batten Strips	Seam Plates	Termination Bars	Other accessories
T.I.S. Sheet No.	Fastener		See the specific fastener TIS for specific application data					
1001	All-Purpose Fastener		✓	✓	✓	✓	✓	✓
1002	Heavy-Duty Fastener	✓	✓	✓	✓	✓	✓	✓
1005	Concrete Drive Fastener	✓	✓	✓	✓	✓	✓	✓
			Do not use with polymer batten strips.					
1006	Polymer Fastener	✓	✓	✓	✓			
			(Special battens and plates required(#))					
1007	Firestone AccuTrac Kit		✓	✓				
			Insulation to steel and wood roof decks with Buildex AccuTrac installation equipment. A kit consists of both fasteners and insulation plates for the AccuTrac tool.					
1009	HD Plus Fastener				✓	✓		
			Firestone Metal Batten Strips in Batten in the Seam (B.I.T.S.), M.A.S and Reinforced MAX, mechanically attached systems.					
1011	Purlin Fastener				✓	✓		
			Membrane and QuickSeam R.M.A. Strip to 12 – 18 gauge structural steel purlins. The Firestone Purlin Fastener can be used in conjunction with Firestone 2" Metal Plates, Firestone V-Plates, or batten strips.					
1012	LWC Base Ply Fastener			✓				
			For the attachment of base sheets. Insulation may not be attached with LWC Base Ply Fastener					
1013	#12 Belted Fastener		✓	✓				
			Insulation to steel (18-24 ga.) and wood. Belted fasteners must be installed with the IF160 automatic installation tool available from SFS INTEC. When used for insulation attachment, the Firestone IFC/PH 2.75" x 2/75" (70 mm x 70 mm) plate is used.					
1014	#15 Belted Fastener		✓	✓				
			Insulation and membrane to steel (18-24 ga.) and wood. The #15 Belted fasteners must be installed with the IF160 installation tool available from SFS INTEC. When used for membrane attachment, the Firestone 2 3/8" (60.3 mm) diameter plate is used. When used for insulation, the Firestone 2.75"x 2.75" (70 mm x 70 mm) plate is used.					
1015	Nail Driver			✓				
			(For the attachment of base sheets. Insulation may not be attached with nails of any kind) Cap nails are to be used to attach a base sheet to a wood deck and cannot be used to attach insulation. Cap nails cannot be used to attach a base sheet through an existing built-up roof when the roof and insulation thickness is over ½" (12.7 mm).					
1019	HailGard Fastener	✓	✓					
			Required use with Firestone Hail Gard Insulation and OSB coverboards to approved decks. No insulation plate required.					

✓ = Acceptable for use

**TABLE 1.05-3
ACCEPTABLE FASTENER PLATE USES**

T.I.S. Sheet No.	Firestone Plates	For use with: ReflexEON and ULTRAPLY TPO Systems	
		ReflexEON .060" UltraPly .045", .060"	ReflexEON .060", Platinum .080" UltraPly .045", .060, Platinum .080"
		Mechanically Attached System (MAS)	Wide Weld (Mechanically Attached)
1101	2" Metal Plate	✓	✓
		For attaching Firestone Reinforced Perimeter Fastening Strips (RPF Strip) to approved substrates as required by Firestone Specifications and Details.	
1102	Polymer Fastener Plate	✓	✓
		For attaching Firestone Reinforced Perimeter Fastening Strips (RPF Strip) to approved substrates as required by Firestone Specifications and Details.	
1106	Insulation Fastening Plate	✓	✓
		For attaching insulation to approved substrates as required by Firestone Specifications and Details.	
1107	Polymer Fastener Insulation Plate	✓	
		For attaching insulation to approved substrates as required by Firestone Specifications and Details.	
1108	HD Seam Plate	✓	
		For attaching Firestone UltraPly TPO membranes to approved substrates as required by Firestone Specifications and Details.	
1109	HD Plus Seam Plate	✓	
		For attaching Firestone UltraPly TPO membranes to approved substrates as required by Firestone Specifications and Details.	
1111	InvisiWeld™ TPO Coated Insulation Fastening Plate	✓	✓
		For attaching insulation and to attach membrane (when induction bonded) to approved substrates as required by Firestone Specifications and Details.	
✓ = Acceptable for use			

**TABLE 1.05-4
ACCEPTABLE BATTEN BAR AND TERM BAR USES**

T.I.S. Sheet No.	Firestone Batten and Termination Bars	For the attachment of: ReflexEON and ULTRAPLY TPO	
		ReflexEON .060" UltraPly .045", .060"	ReflexEON .060", ReflexEON Platinum .080" UltraPly .045", .060, UltraPly Platinum .080"
		Mechanically Attached System (MAS)	Wide Weld (Mechanically Attached)
1201	Coiled metal Batten Strip		✓
		For anchoring membrane to approved substrates as required by Firestone Specifications and Details for Wide Weld	
1202	Metal Batten Strip		✓
		For anchoring membrane to approved substrates as required by Firestone Specifications and Details for Wide Weld	
1204	Polymer Fastener Metal Batten Strip	✓	
		For anchoring membrane to approved substrates as required by Firestone Specifications and Details. Polymer Fasteners Required	
1205	Termination bar	✓	✓
		For anchoring and sealing flashing terminations to approved substrates as required by Firestone Specifications and Details.	
1206	Aluminum Drain Bar	✓	✓
		Used with Firestone Adhered and Ballasted systems for terminating the membrane to approved substrates as required by Firestone Specifications and Details.	
1207	Polymer Batten Strip		✓
		Used for anchoring membrane to approved substrates as required by Firestone Specifications and Details.	
✓ = Acceptable for use			

1.05 Decks

A. Platinum Retrofit or Re-cover Applications:

1. The Firestone Platinum roof systems cannot receive the Firestone Platinum warranty if the existing roof remains in place. A **complete removal** of the existing roof system, including the membrane, insulation and flashings is required.



If present, it is required that phenolic insulation be removed. Once removed, a visual inspection of the deck condition and other components is required; all deteriorated components must be replaced as necessary.

It is the building owner or his design professional's responsibility to determine the condition of the deck.



Sprayed In-Place polyurethane foam (PUF) roof systems require a COMPLETE TEAR-OFF of the Sprayed In-Place polyurethane foam system.

B. General

1. Structural roof decks should be properly designed and constructed to provide sufficient strength to support the anticipated dead and live loads along with the loads anticipated due to the construction traffic, without excessive deflection or movement.
2. Roof replacement usually involves more complexities than new construction roofing. Such contingencies as rusted or deteriorated decks, rotted wood components, rooftop equipment that cannot be moved or shut down, and numerous other conditions are often encountered.
 - a) All holes, deformations, depressions, etc., must be reinforced and /or smoothed prior to the roof application.
 - b) Determination and acceptance of a deck for re-roofing is the responsibility of the building owner or his design professional.
 - c) The deck should provide slope to drain.
3. Refer to Section 1.09 D for fastening requirements for Mechanically Attached Systems should pullout values be less than 400 lbf (181.4 kg).

C. Classification

1. Structural decks can be classified as nailable or non-nailable (sometimes both) for purposes of mechanically attaching or nailing insulation or base sheets. Nailable decks include wood and new decks of gypsum and lightweight insulating concrete. These decks are soft enough so that the above-deck components can be secured with fasteners. Cementitious wood fiber and poured or precast structural concrete decks have been referred to as non-nailable. The term non-nailable is misleading. Firestone Building Products has fasteners that are approved for these decks.
2. Structural decks can be classified as combustible or non-combustible for purposes of fire ratings and code requirements.

**TABLE 1.06-1
STRUCTURAL DECK CLASSIFICATION**

Deck	Nailable or Non-nailable	Combustible or Non-combustible
Steel	Non-nailable	Non-combustible
Concrete	Both	Non-combustible
Wood	Nailable	Combustible
Cementitious Wood Fiber Decks	Both	Non-combustible
Gypsum	Nailable	Non-combustible
Light weight insulated concrete	Nailable	Non-combustible

D. Steel Deck

1. Firestone recommends that the steel deck be a minimum 22 Gauge (0.76 mm).
2. Factory Mutual Research-Approved steel decks are currently available in 22 ga. (0.0295 in, 0.794 mm), 20 ga. (0.0358 in, 0.909 mm) and 18 ga. (0.0474 in, 1.204 mm) thick sheets with 1.5 in (38 mm) deep corrugations. The corrugations (ribs) are cold rolled in the sheets. The deck has a 6 in (152 mm) module, that is, the ribs are 6 in (152 mm) on center. All fastening Approvals and recommendations are based on this profile. (Approved and recommended spacings are such that the fasteners will engage the top flange of the deck). Another common configuration is 3 in (76 mm) deep deck, which usually has an 8 in (203 mm) module.
3. When mechanically attaching a membrane to a steel deck see Section 1.09 D. for specific requirements.
4. When mechanically attaching insulation, steel decks are required to have a fastener pullout of 300 lb per fastener.

5. The Firestone single-ply membrane may not be adhered directly to a steel deck. The single-ply membrane must be adhered to an acceptable insulation or cover board.
6. On steel decks, the edges of insulation boards running parallel with the deck are required to be supported by the top flange of the metal deck. The board should have a minimum 1 ½" bearing on the steel deck flange. Cantilevering insulation boards over deck flutes can fracture insulation boards, reducing the support for the membrane, making it susceptible to puncture.
7. All deteriorated components must be replaced.
8. For retrofit of metal buildings, refer to the Metal Building Recover Specification. Direct attachment of Firestone mechanically attached roof systems to metals roofs (regardless of gauge) is strictly prohibited.

TABLE 1.06-2
ACCEPTABLE FASTENERS FOR INSULATION ON
STEEL DECKS

Firestone Heavy Duty Firestone All Purpose Belted Fasteners	¾" (19 mm) through deck.
Firestone HailGard Fastener No insulation plate required	¾" (19 mm) through deck
Firestone HD Plus	1" (25.4 mm) through deck.

TABLE 1.06-3
ACCEPTABLE INSULATION ADHESIVES FOR
INSULATION ATTACHMENT TO STEEL DECKS

Firestone I.S.O.SPRAY S Firestone I.S.O.FIX II Firestone I.S.O. Twin Pack Firestone I.S.O.Stick Use only 4' x 4' Insulation boards with insulation adhesives.

E. Structural Concrete Roof Decks

1. Firestone recommends that the concrete deck be a minimum 3000 psi (20684 Kpa).
2. Refer to Section 1.09 D for fastening requirements for Mechanically Attached Systems should pullout values be less than 400 lbf (181.4 kg).
3. When mechanically attaching insulation, structural concrete roof decks require a minimum fastener pullout of 300 lb (1.8 kN) per fastener.



The suitability of mechanically fastening insulation or membrane to any hollow core, pre-stressed or post-tensioned structural concrete deck assembly is the responsibility of the design professional. Special consideration needs to be given to the relationship between the deck attachment allowances and Firestone mechanical attachment requirements.

4. Verify with the building owner or his design professional about the suitability of mechanical fastening into pre-stressed, Tubular Concrete and post-tensioned structural concrete.
5. Concrete may contain latent amounts of moisture that may affect the insulation and the roof system. To help protect the components, a Firestone Venting Base Sheet or other vapor retarder material may be installed in accordance with the manufacturer's instructions. The installation of a vapor retarder should be considered whether choosing mechanical attachment, hot asphalt or adhesive attachment of insulation or the membrane system.
6. Pre-cast concrete panels may not always be a suitable substrate to receive insulation due to the potential for irregularities, even if the joints are grouted. It may sometimes be necessary to consider pouring a leveling layer of structural concrete over the panels prior to roofing.

TABLE 1.06-4

SINGLE-PLY ADHESION / ATTACHMENT TO STRUCTURAL CONCRETE ROOF DECKS

ReflexEON Platinum & UltraPly Platinum TPO	
Adhered & Mechanically Attached InvisiWeld™ Plate Induction Bonded System	Firestone ReflexEON Platinum & UltraPly Platinum TPO Roofing System Membranes require a minimum substrate of: ISO 95+ 1" (25.4mm), HailGard 1-1/2" (38.1mm), ISOGARD HD, or 1/4" (6.4mm) DensDeck properly installed for the job conditions.
ReflexEON & UltraPly TPO	
Adhered	The Firestone ReflexEON and UltraPly TPO Roofing System Membrane may be attached directly to poured-in-place structural concrete using Firestone bonding adhesive.
Mechanically Attached InvisiWeld™ Plate Induction Bonded System	Requires protection mat or insulation layer.
UltraPly TPO XR	
Adhered	The Firestone ULTRAPLY TPO XR Membrane Roofing System Membrane may be attached directly to poured-in-place structural concrete with a full coverage of hot asphalt, I.S.O. Spray S Adhesive or Firestone XR Bonding Adhesive or with a bead application of I.S.O. Spray S Adhesive or XR Stick.
UltraPly TPO SA	
Adhered	The Firestone UltraPly TPO SA Roofing Membrane System may be attached directly to a poured-in-place structural concrete. Note: priming may be required prior to application.



When mopping direct to concrete decking, precautions must be taken to protect everything below from dripping hazards of the hot asphalt!

TABLE 1.06-5

ACCEPTABLE FASTENERS FOR CONCRETE ROOF DECKS

Firestone Heavy Duty Firestone HailGard	1" (25.4mm) into the structural concrete deck.
Firestone Concrete Drives	1 1/4" (31.7mm) into the structural concrete deck.

TABLE 1.06-6

ACCEPTABLE INSULATION ADHESIVES FOR INSULATION ATTACHMENT TO STRUCTURAL CONCRETE ROOF DECKS

Firestone I.S.O.SPRAY S
Firestone I.S.O.FIX II
Firestone I.S.O. Twin Pack
Firestone I.S.O.Stick
Hot Asphalt
Use only 4' x 4' Insulation boards with insulation adhesives.

F. Wood Decks: Plywood, OSB and Wood Plank

1. Firestone recommends that plywood and OSB decks have a minimum 7/16" (10.5 mm) thickness.
2. ReflexEON Platinum and UltraPly Platinum single-ply systems must be installed to wood deck with a minimum substrate of 1" ISO 95+ GL.
3. The adhered and mechanically attached single-ply systems may be installed directly to a plywood or OSB deck when:
 - a) The surface is structurally sound, smooth, flat, clean, dry, and free of sharp fins, loose splinters or foreign materials that may damage the membrane.
 - b) The deck is secured using threaded fasteners and plates that provide a smooth profile, meeting FM 4470. *NOTE: Nails are not permitted.*
 - c) Tongue and groove panels are recommended.



Fire treated plywood may be used provided it has not been treated with Ammonium Phosphates.

4. Refer to [section 1.09 D](#) for fastening requirements for Mechanically Attached Systems should pullout values be less than 400 lbf (181.4 kg).
5. When mechanically attaching insulation or other base underlayment sheets, wood decks are required to have a fastener pullout of 300 lb (1.8 kN) per fastener.
6. When nailing a base sheet, wood decks are required to have a fastener pullout of 40 lb (.24 kN) for cap nails per fastener.

**TABLE 1.06-7
SINGLE-PLY ADHESION / ATTACHMENT TO WOOD ROOF DECKS**

ReflexEON Platinum & UltraPly Platinum TPO		
Adhered	Firestone UltraPly Bonding Adhesive	Firestone ReflexEON Platinum & UltraPly Platinum TPO Roofing System Membranes require a minimum substrate of: ISO 95+ GL 1" (25.4 mm), Resista 1" (25.4 mm)HailGard 1-1/2" (38.1 mm), ISOGARD HD Cover Board 1" (25.4 mm) or 3/4" (6.3 mm) DensDeck properly installed for the job conditions.
<ul style="list-style-type: none"> • Mechanically Attached • InvisiWeld™ Plate Induction Bonded System 	Appropriate Fasteners and Batten	
ReflexEON & UltraPly TPO		
Adhered	The Firestone ReflexEON & UltraPly TPO Roofing System Membrane may be adhered directly to a wood deck using UltraPly bonding adhesive.	
<ul style="list-style-type: none"> • Mechanically Attached • InvisiWeld™ Plate Induction Bonded System 	The Firestone UltraPly TPO Roofing System Membrane may be may be mechanically attached directly to a wood deck using the appropriate fasteners and plates or batten bars.	
UltraPly TPO XR		
Adhered	I.S.O Spray S Adhesive; XR Adhesive or XR Stick	
<ul style="list-style-type: none"> • Mechanically Attached 	The Firestone UltraPly TPO XR Roofing System Membrane may be mechanically attached directly to a wood deck using the appropriate fasteners and plates or batten bars.	
UltraPly TPO SA		
Adhered	The Firestone UltraPly TPO SA Roofing Membrane System may be attached directly wooden roof deck. Note: priming may be required prior to application.	

**TABLE 1.06-8
ACCEPTABLE FASTENERS FOR PLYWOOD AND
OSB ROOF DECKS**

Firestone Heavy Duty Firestone All Purpose HailGard Belted Fasteners	1" (25.4mm) into or through deck.
--	-----------------------------------

**TABLE 1.06-9
ACCEPTABLE INSULATION ADHESIVES FOR INSULATION
ATTACHMENT TO PLYWOOD AND OSB ROOF DECKS**

Firestone I.S.O.SPRAY S, Firestone I.S.O.FIX II Firestone I.S.O. Twin Pack, Firestone I.S.O.Stick Use only 4' x 4' Insulation boards with insulation adhesives.

G. Cementitious Wood Fiber Decks

1. Refer to Section 1.09 D for fastening requirements for Mechanically Attached Systems should pullout values be less than 400 lbf (181.4 kg).
2. When mechanically attaching insulation, cementitious wood fiber decks are required to have a fastener pullout of 300 lb (1.8 kN) for each fastener.
3. Firestone recommends that cementitious wood fiber deck have a minimum 2" (51 mm) thickness.
4. The Firestone Roof Membrane cannot be installed directly to a cementitious wood fiber deck. The membrane must be adhered to an acceptable Firestone insulation or coverboard.

TABLE 1.06-10
ACCEPTABLE FASTENERS FOR
CEMENTITIOUS WOOD FIBER DECKS

Firestone Polymer Fastener
1½" (38.1mm) into deck

TABLE 1.06-11
ACCEPTABLE INSULATION ADHESIVES FOR INSULATION
ATTACHMENT TO CEMENTITIOUS WOOD FIBER DECKS

Firestone I.S.O.SPRAY S, Firestone I.S.O.FIX II Firestone I.S.O. Twin Pack, Firestone I.S.O.Stick Use only 4' x 4' Insulation boards with insulation adhesives.

H. Gypsum Roof Decks

1. Firestone recommends that the gypsum roof deck have a minimum 2" (51 mm) thickness.
2. Refer to Section 1.09 D for fastening requirements for Mechanically Attached Systems should pullout values be less than 400 lbf (181.4 kg).
3. When attaching insulation to a gypsum roof deck, a fastener pullout of 300 lb (1.8 kN) per Firestone Polymer Fastener is required.
4. When mechanically attaching a base sheet to a gypsum roof deck, a fastener pullout of 40 lb (0.24 kN) per Firestone LWC Base Sheet Fastener is required.
5. The Firestone Roof Membrane cannot be installed directly to a gypsum roof deck. The membrane must be adhered to an acceptable Firestone insulation or coverboard.

TABLE 1.06-12
ACCEPTABLE FASTENERS FOR GYPSUM ROOF DECKS

Firestone Polymer Fastener	1.2" LWC Base Sheet Fastener
1½" (38.1mm) into deck.	For attaching base sheets to gypsum decks

TABLE 1.06-13
ACCEPTABLE INSULATION ADHESIVES FOR INSULATION
ATTACHMENT TO GYPSUM ROOF DECKS

Firestone I.S.O.SPRAY S, Firestone I.S.O.FIX II, Firestone I.S.O. Twin Pack, Firestone I.S.O.Stick Use only 4' x 4' Insulation boards with insulation adhesives.
--

I. Lightweight Insulating Concrete Roof Decks



For Cellular Lightweight Insulating Concrete decks that are properly prepared and dry, Firestone does not require a vapor retarder, however one is recommended, if insulation is installed with the system. See Technical Bulletin: [2005/10](#)

1. Firestone recommends that the lightweight insulating concrete have a minimum 2" (51 mm) thickness.
2. Refer to Section 1.09 D for fastening requirements for Mechanically Attached Systems should pullout values be less than 400 lbf (181.4 kg).
3. When mechanically attaching insulation through lightweight insulating concrete, into a structural deck, a fastener pullout of 300 lb (1.8 kN) per fastener is required.
4. When mechanically attaching a base sheet to lightweight insulating concrete using Firestone 1.7" LWC Base Ply fasteners, a fastener pullout of 40 lb (0.24 kN) per fastener is required.
5. A vapor retarder is required to be installed under systems with insulation. A properly prepared, existing, dry, and sound, non-insulated built-up roof system (all splits and blisters repaired) can be used as a vapor retarder.

TABLE 1.06-14

SINGLE-PLY ADHESION / ATTACHMENT TO LIGHTWEIGHT INSULATING CONCRETE ROOF DECKS

	New System With Insulation	New System Without Insulation
ReflexEON Platinum & UltraPly TPO Platinum		
Adhered	Insulation and Vapor Retarder Required	Not allowed
Mechanically Attached	Vapor Retarder Required	Not allowed
ReflexEON & UltraPly TPO		
Adhered	Insulation and Vapor Retarder Required	The UltraPly TPO membrane may be fully adhered directly to Cellular Lightweight Insulating Concrete Roof Deck using Firestone Bonding Adhesive. The vapor retarder may be omitted provided that the deck is clean, smooth, dry, free of sharp edges, fins, loose or foreign materials, oil, grease, and other materials, which may damage the membrane.
Mechanically Attached	Insulation and Vapor Retarder Required	The vapor retarder may be omitted provided that the deck is clean, smooth, dry, free of sharp edges, fins, loose or foreign materials, oil, grease, and other materials, which may damage the membrane.
UltraPly TPO XR		
Adhered with Firestone XR Bonding Adhesive; I.S.O. Spray S Adhesive ; or XR Stick	Insulation and Vapor Retarder Required	The UltraPly TPO XR membrane may be fully adhered directly to Cellular Lightweight Insulating Concrete Roof Deck using Firestone XR Bonding Adhesive, I.S.O Spray S Adhesive or XR Stick. The vapor retarder may be omitted provided that the deck is clean, smooth, dry, free of sharp edges, fins, loose or foreign materials, oil, grease, and other materials, which may damage the membrane
Adhered with Hot Asphalt	Insulation and Vapor Retarder Required	Not allowed
Mechanically Attached	Insulation and Vapor Retarder Required	The vapor retarder may be omitted provided that the deck is clean, smooth, dry, free of sharp edges, fins, loose or foreign materials, oil, grease, and other materials, which may damage the membrane.
UltraPly TPO SA		
Adhered	Insulation and Vapor Retarder Required	The UltraPly TPO SA membrane may be fully adhered directly to Cellular Lightweight Insulating Concrete Roof Deck. The vapor retarder may be omitted provided that the deck is clean, smooth, dry, free of sharp edges, fins, loose or foreign materials, oil, grease, and other materials, which may damage the membrane.

TABLE 1.06-15

ACCEPTABLE FASTENERS FOR LIGHTWEIGHT INSULATING CONCRETE ROOF DECKS

Acceptable Fasteners into Steel Pan	
Firestone Heavy Duty (HD's) Firestone HailGard	¾" (19mm) Minimum penetration of fastener through steel pan
Acceptable Fasteners into Structural Concrete Substrate	
Firestone Heavy Duty (HD's) Firestone HailGard	1" (25.4mm) into concrete deck
Firestone Concrete Drives	1 ¼ " (31.8 mm) into concrete deck
Acceptable Fasteners for attaching Base Sheet to Light Weight Insulating Concrete	
Firestone 1.7" LWC Base Ply Fastener	

J. Special Considerations for Partial Tear Off, and Retrofit/Recover Applications



PLATINUM SYSTEMS REQUIRE COMPLETE TEAR OFF.

Existing Roofs over phenolic Insulation requires a COMPLETE TEAR-OFF of the entire roof system to the structural deck.

When phenolic insulation is removed, a visual inspection of the deck condition and other components is required; all deteriorated components must be replaced as necessary.

1. **Partial Tear Off** is the removal of the existing membrane, installing a new layer of insulation over the existing in place insulation and a new membrane over the new insulation.
2. **Retrofit** or **Recover** is the installation of a new roof system installed over an existing roof membrane.
3. The effect of existing moisture on the performance of the new system may be significant depending upon the roofing components selected. Therefore, a moisture survey should be conducted to determine the moisture content of the existing roof system components. All components of the existing system that would be detrimental to the new Firestone roof system must be removed and replaced, in kind, prior to its installation.
4. Limitations in flashing heights may be encountered. Existing building features (i.e., door or window locations, weeps or through-wall flashings) may not allow sufficient clearance to provide proper termination above the potential water level, additional insulation or other details. Detailed consideration of these conditions is critical to the integrity of the roofing system. **Contact your Firestone Technical Coordinator for assistance.**
5. Confirm the structural integrity of the existing deck and specify repair or replacement as required.
6. Existing roof components are not included in the Firestone warranty.
7. Verify that the attachment of the existing roof system is acceptable for the specific new Firestone roof system.

TABLE 1.06-16

SPECIAL CONSIDERATIONS FOR PARTIAL TEAR-OFF AND RETROFIT/RECOVER APPLICATIONS

Deck	Special Considerations
<p>Steel Decks and Nailable Decks (Wood Plank, Plywood, OSB, Gypsum, Cement Wood Fiber, Poured in Place Concrete Decks)</p>	<p>The attachment of the existing system may not be sufficient if the existing insulation is not mechanically fastened or not fastened correctly, or if the existing system contains fasteners that may be corroded. It is strongly recommended that the existing roof system be mechanically attached to the structural deck according to local code, Insurance and Firestone requirements, and prior to installing the new insulation.</p>
<p>Non-Nailable Decks (Poured in Place Concrete Decks, Pre-cast Concrete Decks, Post-Tension Concrete Decks)</p>	<p>If the existing insulation or membrane is not adequately adhered to the deck, it is strongly recommended that the existing roof system be removed to the deck.</p>

 All recover or retrofit systems using adhesives for insulation attachment require a pull test to verify adhesion. Refer to the [Firestone Attachment Guide](#) for adhesion pull test requirements for I.S.O.Fix II, I.S.O.SPRAY S, I.S.O. Twin Pack and I.S.O.Stick.

 When using fasteners, verify that the substrate has sufficient fastener pullout resistance to meet system requirements.

 PLATINUM SYSTEMS REQUIRE COMPLETE TEAR OFF.

K. Partial Tear Off

1. **Partial Tear Off and Recover** is the removal of the existing membrane, installing a new layer of insulation over the existing in place insulation and a new membrane over the new insulation.
2. The existing insulation must be suitable for use as a component of the new roof system. The existing insulation must be:
 - a) Dry and free of trapped moisture.
 - b) Re-secured as necessary to meet Firestone, local code, or other specified wind uplift requirements.
 - c) An acceptable substrate for the new insulation and the new membrane.
3. If existing insulation is to remain, all damaged or wet components must be removed and replaced, in kind, prior to installing the new roof system.
4. Existing roof components are not included in the Firestone warranty.

L. Retrofit / Recover Applications

1. **Existing Smooth Surface Built-Up Or Modified Bitumen Roofs**
 - a) New insulation or coverboard is required, except:
 - (1) When installing an appropriate roof membrane directly to a properly prepared smooth surface BUR or modified bitumen roof. The existing smooth asphalt roof must not have been coated or resaturated.
 - (a) Staining of the UltraPly TPO membrane may occur when attached directly to existing BUR or Modified Bitumen Roof.
 - (b) Bonding to an existing asphalt based roof system is not acceptable when the melting point of the existing asphalt is less than 180 °F.

- (2) UltraPly TPO XR membrane system may be adhered to a properly prepared smooth surface BUR or Modified Bitumen roof. The existing smooth asphalt or Modified Bitumen roof must not have been coated or resaturated.
 - b) All damaged or wet components must be removed and replaced prior to installing the new roof system.
 - c) Existing roof components are not included in the Firestone warranty.
2. **Mineral Surfaced Modified Bitumen**
- a) UltraPly TPO XR membrane system may be adhered to a properly prepared granule modified bitumen roof.
 - b) Insulation, coverboard, or protection mat required, except when installing an UltraPly TPO XR membrane system.
 - c) All damaged or wet components must be removed and replaced, in kind, prior to installing the new roof system.
 - d) Existing roof components are not included in the Firestone warranty.
3. **Asphalt Built Up and Modified Roofs with Flood Coats & Gravel**
- a) New insulation or coverboard is required. Use of 4' x 4' boards is recommended.
 - b) All damaged or wet components must be removed and replaced, in kind, prior to installing the new roof system.
 - c) Existing roof components are not included in the Firestone warranty.
 - d) The removal of loose gravel may be required to meet local building code requirements or for structural consideration. If loose gravel is removed, some method of leveling may be required to provide a suitable substrate for the insulation.
4. **Coal Tar Built-Up Roofs**
- a) New insulation or coverboard is required.
 - b) All damaged or wet components must be removed and replaced, in kind, prior to installing the new roof system.
 - c) Flow of existing coal tar into the building may occur when new fasteners penetrate an existing coal tar pitch membrane.



Flow of existing coal tar into the building may occur when new fasteners penetrate an existing coal tar pitch membrane and substrate system.

- d) The removal of loose gravel may be required to meet local building code requirements or for structural consideration. If loose gravel is removed, some method of leveling may be required to provide a suitable substrate for the insulation.
 - e) Existing roof components are not included in the Firestone warranty.
5. **Existing Single-Ply Systems**
- a) New insulation or coverboard is required.
 - b) Recover over single-ply roof systems require that all existing base tie-ins be removed or cut prior to the new roof installation.
 - c) All damaged or wet components must be removed and replaced, in kind, prior to installing the new roof system.
 - d) Existing roof components are not included in the Firestone warranty.

M. Existing Gravel, Smooth, and Granule Surfaced Asphalt Membranes

1. Verify that the attachment of the existing roof system is acceptable. If existing insulation is not mechanically fastened, contains fasteners that may be corroded or loose, or the attachment may not be sufficient,

consideration should be given to re-attaching the roof system prior to installing the new insulation.

2. When adhering insulation to gravel surfaced roof, all loose gravel or granules must be removed by vacuuming and/or, power brooming. After all loose gravel has been removed; spud the remaining gravel smooth to provide a level surface.
3. If adhering the insulation or cover board with asphalt, prime the surface using an ASTM D 41 asphalt primer.
4. The existing assembly should be re-secured as necessary to meet local code and insurance or design wind uplift requirements.



Sprayed In-Place polyurethane foam (PUF) roof systems require a COMPLETE TEAR-OFF of the Sprayed In-Place polyurethane foam system.



Existing roofs over phenolic Insulation requires a COMPLETE TEAR-OFF of the entire roof system to the structural deck. When phenolic insulation is removed, a visual inspection of the deck condition and other components is required; all deteriorated components must be replaced as necessary.

1.06 Base Sheet

A. General

1. Depending on the base sheet and the substrate, base sheets may be attached with fasteners, hot asphalt, or heat fusing as required by the specifications.
2. The Firestone modified base sheets and base plies must be installed so that all laps shed water.
3. Where the slope exceeds 1/2": 12" (4.2%) and hot asphalt is required, Firestone recommends that Firestone SEBS Mopping Asphalt or Type IV asphalt be used. See also Table 1.03-1 for attachment of asphalt membranes on slopes.
4. Firestone does not manufacture or supply Type III or Type IV asphalt and does not warrant the performance of products Firestone does not supply.

**TABLE 1.07-1
ALLOWABLE BASE SHEET ATTACHMENTS**

Substrate To Which Base Sheet or Base Ply Will Be Attached	Attachment Method		
	Mechanically Attached	Heat Weld	Hot Asphalt
Decks			
Structural Concrete	✓	✓	✓
Plywood Or Oriented Strand Board	✓		
Wood Planking	✓		
Poured Or Pre-Cast Gypsum	✓		
Cementitious Wood Fiber	✓		
Lightweight insulating concrete Decks And Fills (See Section 1.06 H for additional requirements)	✓		
Recover			
Existing Smooth Surface Built-Up Or Modified Bitumen Roofs		✓	✓
Asphalt Gravel Surfaced Built-Up Roofs			✓
Mineral Surface Built-Up Or		✓	✓

Modified Bitumen Roofs			
New Insulation / Cover Board			
ISOGARD HD	✓		✓
FiberTop	✓		✓
HailGard	✓		
Dens-Deck Products		✓	✓
Reference must be made to other sections of the Single Ply Design Guide, the Asphalt Design Guide, Detail Drawings, and Technical Information Sheets (T. I. S.) for additional and/or specific requirements.			
✓ = Acceptable for use			

 Roofing plies, base sheets, or cap sheets cannot be fully mopped to polyiso insulation. An overlay must be used to separate the polyiso insulation from the fully adhered, hot asphalt applied, ply.

1.07 Insulation

A. General

1. Insulation must provide a suitable substrate for the proposed roof system as well as insulation for the building.
2. Insulation thickness requirements may vary for code compliance. Contact the local code or insurance official before contacting Firestone Roof System Solutions Group.
3. Refer to Insulation or Coverboard Technical Information Sheet (TIS) for specific spanning capabilities.

 Only Firestone brand insulation can be included in the Firestone Red Shield warranty.

4. Refer to the Firestone Attachment Guide for adhesion pull test requirements for I.S.O.Fix II, I.S.O.SPRAY S, I.S.O. Twin Pack and I.S.O.Stick.

B. Attachment

1. Insulation may be installed by various methods including fasteners, adhesives and asphalt. It is acceptable to combine fastener and adhesive attachment methods in multi-layer applications.
2. Tapered insulation below the 1.0" (25.4 mm) minimum thickness must be fastened at a rate of one (1) fastener and plate per two (2) square feet (0.22 sq m). If possible, install the tapered insulation first, covered by the flat stock.
3. Refer to specific Firestone Technical Information Sheets (TIS) for installation and fastening requirements.
4. When a composite of two insulation layers is installed, the fastening pattern required for the top board thickness must be used. A common fastener may be used to install multilayer applications. Some restrictions apply to fastener length depending on standards used.

 Ballasted systems are not allowed when the membrane is installed directly onto a hard surface, such as Dens Deck, OSB, Gypsum or concrete.
Ballasted systems are not allowed when the membrane is installed directly to a layer of insulation, which has been mechanically attached.

C. Multiple Layers of Insulation

1. Where overall insulation thickness is 2 inches (50.8 mm) or greater, Firestone recommends installing the insulation in two (2) or more layers.
2. Insulation may be installed in one or multiple layer applications for the Firestone warranty. If installed in multiple layers, the joints of each succeeding and adjoining layer should be staggered from the joints of previous layers by a minimum of 6 inches (152.4 mm) in each direction.
3. When a composite of two insulation layers is installed, the fastening pattern required is dependant on the top board type and thickness. A common fastener may be used to simultaneously fasten all layers to the structural deck.

TABLE 1.08-1

INSULATION/COVER BOARD ATTACHMENT OPTIONS BY DECK AND RECOVER / RETROFIT

Substrate To Which Insulation / Cover Board Will Be Attached or Adhered	Attachment Method					
	Mechanically Attached	I.S.O.Fix II	I.S.O. SPRAY S	I.S.O. Twin Pack	I.S.O. Stick	Hot Asphalt
		Adhesive attachment may require a primer and an adhesive pull test. See the Firestone Attachment Guide				
DECKS						
Steel	✓	✓	✓	✓	✓	N/A
Structural Concrete	✓	✓	✓	✓	✓	✓
Plywood Or Oriented Strand Board	✓	✓	✓	✓	✓	N/A
Wood Planking	✓	✓	✓	✓	✓	N/A
Poured Or Pre-Cast Gypsum	✓	✓	✓	✓	✓	N/A
Cementitious Wood Fiber	✓	✓	✓	✓	✓	N/A
Lightweight Insulating Concrete Decks (See Section 1.06 H for additional requirements)	✓	N/A	N/A	N/A	N/A	N/A
RECOVER/RETROFIT						
Existing Smooth Surface Built-Up Roof Or Modified Bitumen Roofs	N/A	✓	✓	✓	✓	✓
Coal Tar Built-Up Roofs	N/A	N/A	✓	✓	✓	✓
Asphalt Gravel Surfaced Built-Up Roof	N/A	N/A	✓	N/A	N/A	✓
Mineral Surface Built-Up Roof Or Modified Bitumen Roof	N/A	✓	✓	✓	✓	✓
V-Force Vapor Barrier Membrane	✓	✓	✓	✓	✓	N/A
Firestone recommends mechanically attaching a Cover board over existing insulation. The responsibility of identifying and removal of damaged or wet insulation is that of the contractor.						
Sprayed Urethane Roof (PUF)	Complete tear-off required					
Existing Roof with Phenolic Insulation	Complete tear-off required When Phenolic insulation is removed, a visual inspection of the deck condition and other components is required, all deteriorated components must be replaced as necessary					
Refer to the Firestone Attachment Guide for adhesion pull test requirements for I.S.O.Fix II, I.S.O.SPRAY S, I.S.O. Twin Pack and I.S.O. Stick						
✓ = Acceptable for use N/A = Not Applicable						

TABLE 1.08-2

INSULATION / COVER BOARD ATTACHMENT TO INSULATION OPTIONS BY INSULATION TYPE

Base Layer of Insulation To Which Insulation / Cover Board Will Be Adhered	Insulation / Cover Board to Insulation Attachment Method				
	I.S.O.Fix II	I.S.O. SPRAY S	I.S.O. Twin Pack	I.S.O.Stick	Hot Asphalt
Insulation					
ISO 95+ GL	✓	✓	✓	✓	✓
Resista	✓	✓	✓	✓	✓
ISOGARD HD	✓	✓	✓	✓	N/A
Fibertop	✓	✓	✓	✓	✓
Dens-Deck	✓	✓	✓	✓	✓
Dens-Deck Prime	✓	✓	✓	✓	✓
Perlite Insulation	N/A	N/A	N/A	✓	✓
Asphalt Base Sheet	✓	✓	✓	✓	✓
V-Force Vapor Barrier Membrane	✓	✓	✓	✓	N/A
Firestone recommends mechanically attaching a Cover board over existing insulation. The responsibility of identifying and removal of damaged or wet insulation is that of the contractor.					
Refer to the Firestone Attachment Guide for adhesion pull test requirements for I.S.O.FixII, I.S.O.SPRAY S, I.S.O. Twin Pack and I.S.O.Stick					
✓ = Acceptable for use N/A = Not Applicable					

D. Mechanical Attachment of Insulation and Cover Board to Approved Substrates

1. Insulation must be fastened with appropriate Firestone fasteners and insulation plates.
2. Firestone All Purpose (AP's) fasteners are not acceptable for any 25 or 20 -year systems, 15-year Recover, or Partial Tear off applications.
3. The insulation must be installed in accordance with the fastening rate and pattern for the applicable system, as shown on the Technical Information Sheet 950.
4. Fastening rates and patterns may vary for code or regulatory compliance. Contact local code or insurance official before contacting Firestone's Roof System Solutions Group.
5. When a composite of two insulation layers is installed, the fastening pattern required is dependant on the top board type and thickness. A common fastener may be used to simultaneously fasten all layers to the structural deck.
6. In areas where tapered insulation thickness is below the 1.0" (25.4 mm) minimum thickness, the insulation must be fastened at a rate of one (1) fasteners per two (2) ft² (0.22 m²).
7. Firestone's published reduced fastening rates for ISO 95+ GL insulation, under selected conditions, will not affect the products performance. However, the reduced fastening rate may allow insulation board movement that may result in interior building noise.

**TABLE 1.08-3
INSULATION ATTACHMENT OPTIONS
(MECHANICAL ATTACHMENT)**

Structural Deck To Which Insulation/ Cover Board Will Be Mechanically Attached	Attachment Method						Minimum penetration of fastener into/ through deck
	Firestone All Purpose (AP) and Plates	Firestone Heavy Duty (HD) and Plates	Firestone Polymer Fasteners and Plates	Firestone Concrete Drives and Plates	Firestone Belted Fastener and Plates	Firestone HailGard	
Steel	✓	✓	N/A	N/A	✓	✓	¾" (19 mm) through deck
Structural Concrete	N/A	✓	N/A	✓	N/A	✓	HeavyDuty(HD) or HailGard 1" (25.4 mm) into deck
							Concrete Drives 1¼" (31.7 mm) into deck
Plywood or OSB	✓	✓	N/A	N/A	✓	✓	1" (25.4 mm) into or through deck
Wood Plank	✓	✓	N/A	N/A	✓	✓	1" (25.4 mm) into or through deck
Gypsum	N/A	N/A	✓	N/A	N/A	N/A	1½" (38.1 mm) into deck.
Cementitious Wood Fiber	N/A	N/A	✓	N/A	N/A	N/A	1½" (38.1 mm) into deck.
Lightweight insulating concrete over steel deck <small>(See Section 1.06 H for additional requirements)</small>	N/A	✓	N/A	N/A	N/A	✓	Heavy Duty (HD) or HailGard ¾" (19 mm) through steel pan
Lightweight insulating concrete over concrete deck <small>(See Section 1.06 H for additional requirements)</small>	N/A	✓	N/A	✓	N/A	✓	Heavy Duty (HD) or HailGard 1" (25.4 mm) into the structural concrete deck.
							Concrete Drives 1¼" (31.7 mm)) into the structural concrete deck.
✓ = Acceptable for use N/A = Not Applicable							

E. Minimum Number of Fasteners and Plates Per Insulation Board

1. See **Firestone T.I.S. 950 Insulation Attachment Patterns** for the required patterns for proper placement of approved fasteners and plates for insulation on Firestone minimum roof systems specifications. These fastening patterns apply to the following flat or tapered insulations. The most common fastener density and pattern requirements are shown on this Technical Information Sheet. For non-standard fastener densities, contact the Firestone Roof System Solutions Group.
2. Certain specifications and job conditions may call for increased densities of fasteners in the perimeters and corners of roofs.

TABLE 1.08-4

MINIMUM NUMBER OF FASTENERS AND PLATES PER INSULATION BOARD

System	Insulation	Insulation Thickness	Number of Fasteners per 4' x 4' Board	Number of Fasteners per 4' x 8' Board	
Mechanically Fastened Systems	ReflexEON Platinum UltraPly Platinum	ISO 95+ GL	1"	4	5
		Resista	1"	4	5
	New Construction or complete tear off to the deck with any damage repaired or replaced	ISOGARD HD	1/2" or 1"	4	5
		DensDeck	1/4"	4	5
		HailGard	1.5"	4	5
	ReflexEON Platinum UltraPly Platinum	ISO 95+ GL	1"	8	16
		ISOGARD HD	1/2" or 1"	8	16
		DensDeck	1/4"	8	16
		HailGard	1.5"	8	16
	ReflexEON TPO UltraPly TPO UltraPly TPO XR New Construction with NO Air/vapor Barrier or Not over a BUR, Modified, or Adhered Single-Ply System	All Firestone Approved Insulations	All Approved	4	5
	ReflexEON TPO UltraPly TPO UltraPly TPO XR New Construction with an Air/Vapor Barrier or a recover over existing loose laid or Mechanically Attached Single-Ply System Single-Ply System	Firestone ISO 95+ GL	1" - 1.4"	8	16
			1.5" - 1.9"	6	12
			2" - 4"	4	8
		Resista	1"	8	16
		ISOGARD HD	1/2" or 1"	6	12
		HailGard	1.5" of Greater	8	16
Firestone FiberTop		.5" - 1"	4	5	
DensDeck		1/4"	8	16	
		1/2"	6	12	
		5/8"	4	8	
DensDeck Prime	1/4"	6	12		
	1/2"	5	10		
	5/8"	4	8		

TABLE 1.08-5

MINIMUM NUMBER OF FASTENERS AND PLATES PER INSULATION BOARD

System		Insulation	Insulation Thickness	Number of Fasteners per 4' x 4' Board	Number of Fasteners per 4' x 8' Board
Fully Adhered systems	ReflexEON Platinum & UltraPly Platinum	Firestone ISO 95+ GL	1"-4"	8	16
		Resista	1"	8	16
		HailGard	1.5" or greater	8	16
		DensDeck	¼" or greater	8	16
	ReflexEON TPO UltraPly TPO UltraPly TPO XR Ultraply TPO SA	Firestone ISO 95+ GL	.5" - 1.4"	8	16
			1.5" – 1.9"	6	12
			2" or Greater	4	8
		Resista	1"	8	16
		ISOGARD HD	0.5"	6	12
			1.0"	6	12
		Firestone Composite FiberTop Wood Fiber Board	1.5" or Greater	6	12
		DensDeck	.5" – 1"	8	16
			¼"	8	16
			½"	6	12
		DensDeck Prime	5/8"	4	8
			¼"	6	12
			½"	5	10
			5/8"	4	8

TABLE 1.08-6

MINIMUM FASTENER PULLOUT RESISTANCES FOR SPECIFIC SYSTEMS

System	Minimum Fastener Pullout
Fully Adhered systems with Insulation Mechanically Attached to Deck	300 lb (136.1 kg)
Single-Ply Mechanically Attached.	400 lb (181.4 kg)
Base Sheet Mechanically Attached to Deck	300 lb (136.1 kg)
Base Sheet Nailed to Deck (Cap nail or Firestone LWC Fastener)	40 lb (18.1 kg)

NOTE: In the case where the structural deck does not meet the minimum fastener pullout requirements contact your Technical Coordinator at Firestone Building Products.

F. Asphalt Attachment of Insulation /Cover Board to Substrate

1. The proposed insulation or cover board must be compatible with the roof substrate, the proposed bitumen and the requirements of the Firestone roof system.
2. Hot steep asphalt (ASTM D 312 Type III or Type IV) may be used to attach insulation beneath a ballasted, fully adhered or mechanically attached roof system.
3. When using hot asphalt for attachment:
 - The insulation must be no larger than 4' X 4' (1.2 m X 1.2 m)
 - Stagger all insulation joints from adjoining boards and subsequent layers by 6" (153mm)
4. Assure that all health and safety measures are followed when installing hot asphalt to protect the installers as well as occupants of the building.
5. Expanded or Extruded Polystyrene can not be attached using Hot Asphalt.

TABLE 1.08-7

APPROVED SUBSTRATES FOR USE WITH ASPHALT ATTACHMENT OF INSULATION /COVER BOARD

Approved base sheets that have been attached in accordance with Firestone requirements		✓
Approved base plies that have been adhered in accordance with Firestone requirements		✓
Compatible insulations	ISO 95+ GL	✓
Compatible Cover Boards	Approved Dens Deck Products (Dens Deck must be primed with ASTM D 41)	✓
Poured-in-Place or pre-cast structural concrete decks that has been primed with ASTM D 41 primer		✓
Existing properly prepared asphalt membrane roof systems.	Uncoated smooth or granular surfaced BUR	✓
	Granule surfaced SBS modified asphalt roof systems	✓
	Gravel surface Built-Up roof systems (gravel removed)	✓
✓ = Acceptable for use		

G. Adhesive Attachment of Insulation /Cover Board to Substrate

1. Assure that all safety measures are followed when installing insulation adhesives to protect the installer as well as the occupants of the building.
2. Firestone insulation adhesives must be applied in accordance with the installation instructions and [Technical Information Sheet](#) (TIS).
3. Firestone I.S.O.SPRAY S, I.S.O.FIX II, I.S.O. Twin Pack and I.S.O.Stick Adhesives:
 - The insulation must be no larger than 4' X 4' (1.2 m X 1.2 m)
 - Stagger all insulation joints from adjoining and adjacent boards and adjacent layers, 6" (153 mm) minimum.
4. Refer to the [Firestone Attachment Guide](#) for adhesion pull test requirements for I.S.O. Fix, I.S.O. SPRAY S, I.S.O. Twin Pack and I.S.O.Stick.
5. Existing decks containing residual asphalt must be cleaned and scraped as smooth as possible.
6. Existing decks shall be smooth, flat, clean, dry, free of sharp fins, or foreign materials.

TABLE 1.08-8

ALLOWABLE ADHESIVE ATTACHMENT OF INSULATION /COVER BOARD TO STRUCTURAL DECK

Structural Deck To Which Insulation or Cover Board Will Be Adhered	I.S.O.FIX II			I.S.O.SPRAY S			I.S.O. Twin Pack Or I.S.O.Stick			Notes
	Acceptable	Pull Test Required	Not-Acceptable	Acceptable	Pull Test Required	Not-Acceptable	Acceptable	Pull Test Required	Not-Acceptable	
Steel	✓			✓			✓			New steel decks require cleaning to remove processing oils
New Structural Concrete	✓			✓			✓			
Existing Structural Concrete		✓		✓				✓		Existing concrete containing residual asphalt must be cleaned and scraped smooth as possible
Plywood, OSB, Wood Planking	✓			✓			✓			
Cementitious Wood Fiber	✓			✓			✓			

Poured Or Pre-Cast Gypsum		✓		✓				✓	
V-Force Vapor Barrier Membrane	✓			✓				✓	
Lightweight Insulating Concrete Decks (See Section 1.06 H for additional requirements)			✓			✓			✓
✓ = Acceptable for use									

TABLE 1.08-9

ALLOWABLE ADHESIVE ATTACHMENT OF INSULATION /COVER BOARD TO BASE LAYER OF INSULATION

New Base Layer Of Insulation Or Asphalt Base Sheet To Which Insulation Or Cover Board Will Be Adhered	I.S.O.FIX II			I.S.O.SPRAY S			I.S.O. Twin Pack Or I.S.O.Stick			Notes
	Acceptable	Pull Test Required	Not-Acceptable	Acceptable	Pull Test Required	Not-Acceptable	Acceptable	Pull Test Required	Not-Acceptable	
ISO 95+ GL	✓			✓			✓			Maximum 4' x 4' (1.2 m x 1.2 m) boards only on approved insulations I.S.O.FIX II Maximum slope: 2:12
Resista	✓			✓			✓			
ISOGARD HD	✓			✓			✓			
Fibertop	✓			✓			✓			
HailGard			✓			✓			✓	
Dens-Deck Products	✓			✓			✓			
Perlite Insulation			✓			✓			✓	
V- Force Vapor Barrier Membrane	✓			✓			✓			
Approved Firestone Asphalt Base Sheets		✓		✓			✓			

TABLE 1.08-10

ALLOWABLE ADHESIVE ATTACHMENT OF INSULATION /COVER BOARD TO RETROFIT / RECOVER

Recover / Retrofit To Which Insulation or Cover Board Will Be Adhered	I.S.O.FIX II			I.S.O.SPRAY S			I.S.O. Twin Pack Or I.S.O.Stick			Notes
	Acceptable	Pull Test Required	Not-Acceptable	Acceptable	Pull Test Required	Not-Acceptable	Acceptable	Pull Test Required	Not-Acceptable	
Smooth Surface BUR		✓		✓				✓		Primer may be required
Existing Asphalt Roofs Gravel Surfaced BUR Mineral Surface BUR Mineral Surface Modified		✓		✓				✓		All interruptions in the existing roof membrane must be re-sealed to prevent air infiltration. Primer may be required
Coal Tar Pitch BUR			✓	✓			✓			Aged and oxidized, Primer may be required
Existing Single-Ply Systems			✓			✓			✓	Not Acceptable

Firestone Building Products
I.S.O. Twin Pack; I.S.O. Stick; I.S.O. Spray S; and I.S.O.FIX II
Insulation Adhesive Layout Guide

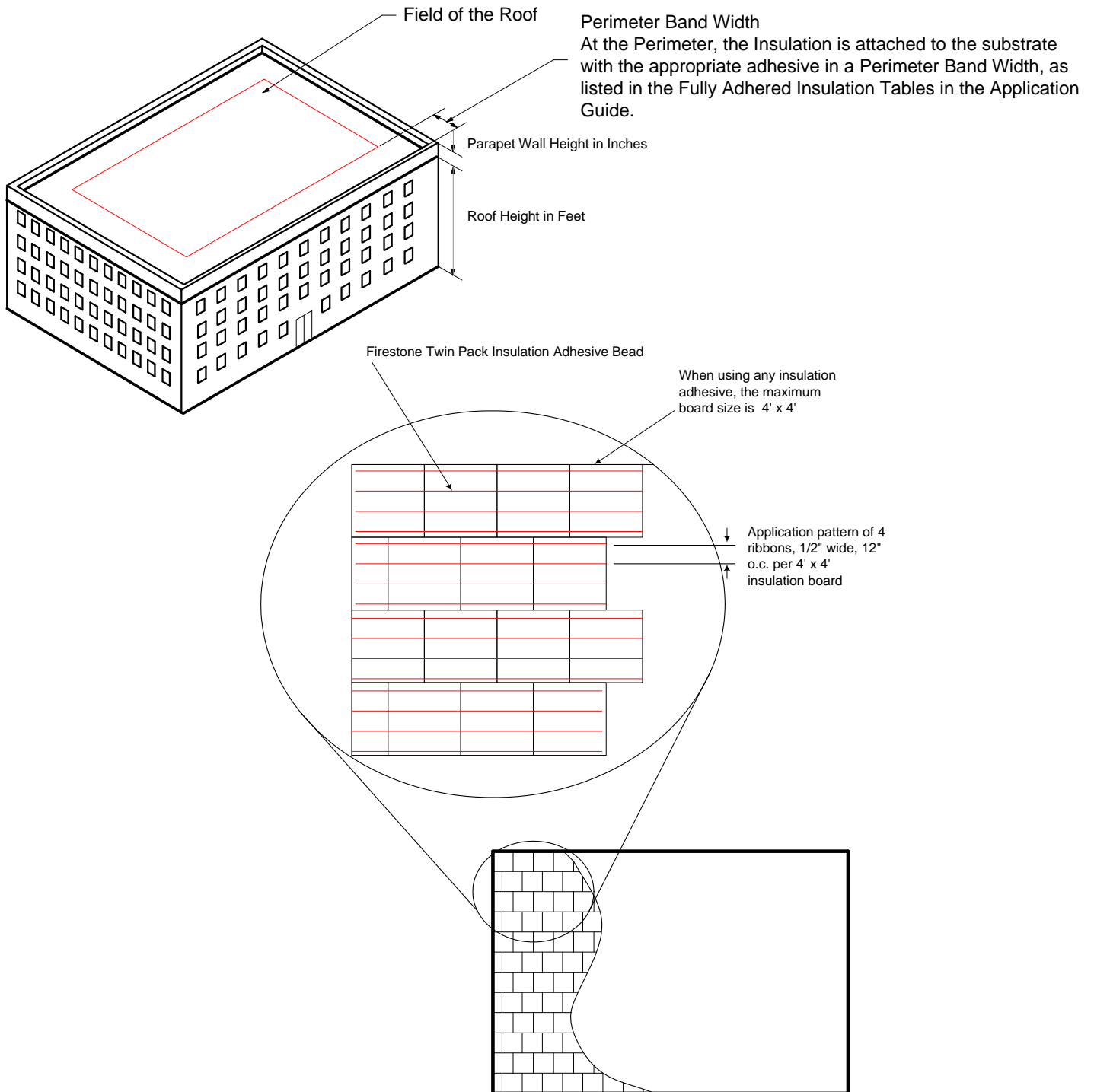

Application Rate

Firestone Insulation Adhesives are installed in 1/2" to 3/4" beads spaced 12" o.c. for Firestone minimum standard installation. Application rates will increase as job requirements become more demanding.

Primer may be required, depending on the substrate.

Criteria for Field Testing Firestone Insulation Adhesive for Adhesion to Deck Substrates

1. Prepare an area large enough to allow a 4' x 4' insulation board to be laid in place. Follow Firestone guidelines for surface preparation and list of acceptable substrates or contact your Firestone Technical Coordinator at 1-800-428-4511.
2. Apply the adhesive to the deck per recommended application rates and methods (12" o.c., ½" to ¾" bead).
3. Allow the adhesive a **minimum of 60 minutes to cure**. This period should be sufficient in almost any temperature to indicate the adhesion values required for the test. *
4. After the adhesive has been allowed to cure, pull up on the adhered board by placing a hand under the corner or end of the board in the same direction as the ribbons. Make sure that the board is **lifted by hand**. Using tools to scrape the board sometimes dis-bonds the adhesive from the deck. This will not show whether the adhesive is performing under uplift considerations (If a tool is used, it should be used to **pry or pop the board up**).
5. Observe the insulation and deck. The desired result is a de-lamination of the surface or board facer with adhesive and facer residue remaining on the deck or the board breaks apart remaining adhered to the deck at the ribbons. **If the board is lifted and the adhesive pulls/peels off the deck or decking is pulled up with the board, contact your Firestone Technical Coordinator at 1-800-428-4511. This will be considered an unacceptable substrate.**

1.08 Roof Membrane

A. Membrane Securement Options For Single-Ply Membrane Systems

1. The following section outlines the various securement options for individual system types. Compliance with all installation criteria is required to issue a Firestone Warranty. Additional attachment requirements may be necessary to comply with design criteria, insurance requirements or the local building code.
2. An air barrier is required for projects with large wall openings that are greater than 10% of any one wall area that could be left open in a storm. Criteria for enhancements to be determined based upon Firestone's review. Contact **your Firestone Technical Coordinator at 1-800-428-4511**.

TABLE 1.09-1

**APPROVED IMMEDIATE INSULATION SUBSTRATES FOR SINGLE-PLY MEMBRANES
UP TO AND INCLUDING 25-YEAR WARRANTIES**

New Firestone Insulation or Approved Firestone Base Sheet To Which Membrane Can Be Applied	Any Firestone TPO Membrane		
	Adhered	Mechanically Attached	Ballasted (Only eligible for up to a 20 year warranty)
ISO 95+ GL	✓	✓	✓
ISOGARD HD	✓	✓	✓
Resista	✓	✓	✓
FiberTop (Applicable for 15 Year or less Warranties)	✓	✓	✓
HailGard	✓	✓	
Dens-Deck Products	✓	✓	
Perlite Insulation			✓
EPS/XPS Insulation			✓
Fiberglass Insulation			✓
✓ = Acceptable for use			

TABLE 1.09-2

**APPROVED IMMEDIATE DECK SUBSTRATES FOR SINGLE-PLY MEMBRANES
UP TO AND INCLUDING 20-YEAR WARRANTIES**

Structural Deck To Which Membrane Will Be Directly Can Be Applied	Any Firestone TPO Membrane		
	Adhered	Mechanically Attached	Ballasted
Decks			
Structural Concrete	✓	✓	
Plywood or Oriented Strand Board	✓	✓	
Wood Planking	✓	✓	
Poured Or Pre-Cast Gypsum			
Cementitious Wood Fiber			
Lightweight Insulating Concrete Decks (See Section 1.06 H for additional requirements)		✓	
✓ = Acceptable for use			

TABLE 1.09-3
APPROVED IMMEDIATE SUBSTRATES FOR SINGLE-PLY MEMBRANES
UP TO AND INCLUDING 15-YEAR WARRANTIES

Properly Prepared Recover / Retrofit Substrate To Which Membrane Will Be Directly Can Be Applied	Any Firestone TPO Membrane		
	Adhered	Mechanically Attached	Ballasted
Recover			
Smooth Surface Built-Up Or Modified Bitumen Roofs (Applicable for 15 Year or less Warranties)	✓	✓	
Mineral Surface Built-Up Or Modified Bitumen Roofs (Applicable for 15 Year or less Warranties)			
✓ = Acceptable for use			

B. Adhered Systems

TABLE 1.09-4
ADHESIVES FOR SINGLE-PLY MEMBRANES TO APPROVED SUBSTRATES

Adhered Single-Ply System	UltraPly Bonding Adhesive; Single-Ply LVOC Bonding Adhesive; and Single-Ply Bonding Adhesive 1168	Water based Bonding Adhesive	XR Adhesive	Asphalt	I.S.O Spray S Adhesive	XR Stick
ReflexEON Platinum, UltraPly Platinum, ReflexEON, UltraPly TPO	✓	✓				
UltraPly TPO XR			✓	✓	✓	✓
✓ = Acceptable for use						

C. Ballasted Systems



Ballasted systems are not allowed when the membrane and ballast is installed directly onto a hard surface, such as Dens Deck, OSB, gypsum or concrete.

Insulation fasteners / plates are not approved for use directly under a ballasted membrane system.

Firestone requires that a suitable insulation or coverboard be installed over any substrate that would damage the membrane. This includes, but is not limited to:

- Fasteners / plates used for insulation attachment
- Fasteners / plates used for existing membrane / insulation securement
- Substrates that are not smooth, flat, clean, free of sharp fins, or foreign materials that could damage the membrane

1. Ballast

- a) All ballast should be of adequate size and weight to provide proper protection against wind uplift. The building owner or his design professional is responsible for the ballast design and selection on a specific building. Firestone can assist with its Firestone Ballast Paver system in selection and design. Firestone does not certify or comment on stone ballast other than to state the requirements for warranty described in this Technical Database. Regarding size and roughness of stone ballast, refer to local building codes,

the ANSI/SPRI “Wind Design Standard for Ballasted Single-Ply Roofing Systems RP-4” or Factory Mutual Technical Advisory Bulletin 1-29 for information regarding stone ballast requirements on loose laid single-ply roofing systems.

- b) The weight of ballast must be considered when determining the structure’s ability to support the load of staged materials or the completed roof installation and other expected loads. Firestone takes no responsibility for making this structural analysis, but strongly recommends that a professional engineer or registered architect make this determination prior to the job start.
 - c) Install ballast materials on a daily basis as a maximum time frame. Failure to do so may cause damage to the system from wind or allow movement of the insulation.
 - d) Do not stock pile ballast materials.
2. Stone Ballast:
- a) Stone ballast should be smooth, water worn gravel with rounded edges and corners, relatively free of fractures, loam, sand, or other foreign substances and contain no more that 4% fines.
 - b) Unless otherwise designed, the minimum ballast coverage required by Firestone for warranty is 10 lb/ft² (48.8 kg/m²) using nominal ¾” to 1-1/2” (19.0 mm to 38.1 mm) diameter stone meeting ASTM D 448 size #4 using ASTM C-136 method of testing.
 - c) This rate may not provide adequate membrane coverage if stone larger than ASTM D 448 size #4 is used.

TABLE 1.09-5
MINIMUM COVERAGE REQUIREMENTS FOR VARIOUS BALLAST GRADATIONS

ASTM Size No.	Nominal Size	Minimum Acceptable Coverage
4 (Firestone Minimum)	¾” (19 mm) to 1-1/2” (38 mm)	10 lb/sq ft (48 kg/sq m)
357	¾” (19 mm) to 2” (51 mm)	10 lb/sq ft (48 kg/sq m)
3	1” (26 mm) to 2” (51 mm)	10 lb/sq ft (48 kg/sq m)
24	¾” (19 mm) to 2-1/2” (63 mm)	11 lb/sq ft (54 kg/sq m)
2	1-1/2” (38 mm) to 2-1/2” (63 mm)	13 lb/sq ft (63 kg/sq m)
1	1-1/2” (38 mm) to 3-1/2” (89 mm)	16 lb/sq ft (78 kg/sq m)

3. Concrete Pavers:
- a) The Firestone Roof Ballast Paver system consists of smooth trowel finished interlocking concrete pavers, and may be used, and should be applied at a rate of not less than 12 lb/ ft² (58.48 kg/m²). Maximum space between pavers should be ½” (13 mm).
 - b) Interlocking paving stones weighing a minimum of 10 lb/ft² (48.8 kg/m²), which have proven performance for wind and weather resistance, may be used. This system should have a minimum performance warranty from the paver manufacturer equal to the Firestone roof warranty.
 - c) Firestone Protection Mat or an additional layer of Firestone Membrane must be installed between the membrane and all pavers. The Firestone Protection Mat must be completely covered with pavers in order to prevent ultraviolet degradation of the mat.
4. Crushed Stone Ballast:
- a) Crushed stone ballast should be durable, free of excessive fractures, loam, sand or other foreign substance, meeting the following physical testing requirements:
 - b) Firestone Protection Mat or an additional layer of Firestone Membrane must be installed between the membrane and the crushed stone ballast. The Firestone Protection Mat must be completely covered with the crushed stone ballast in order to prevent ultraviolet degradation of the mat.
 - c) Specific Gravity: Minimum 2.40 Mg/cu m (ASTM C 127 test method)
 - d) Impact Resistance: Maximum 40% weight loss (ASTM C 535 and C 131 test methods)
 - e) Soundness: (ASTM C 88 test method)
 - f) Maximum 12% weight loss (with sodium sulfate)
 - g) Maximum 18% weight loss (with magnesium sulfate)

- h) Unless otherwise designed, the minimum ballast coverage required by Firestone for warranty is 10 lb/ ft² (48.8 kg/m²) using nominal ¾" to 1-1/2" (19 mm to 38 mm) diameter stone.

D. Mechanically Attached Systems

Within Firestone Specifications, reference is made to Firestone's Mechanically Attached Systems. Mechanically Attached TPO Systems by definition include:

- Batten in The Seam – **BITS**
- Mechanically Anchored System (Reinforced TPO Membrane) – **MAS**
- UltraPly TPO InvisiWeld induction welded mechanically attached - **IW**
- UltraPly TPO Reinforced Mechanically Anchored System – **R.M.A.**



Firestone recommends that when installing mechanically attached membranes over steel decks, the field attachment should run perpendicular the deck panels.

1. See The Firestone Attachment Guide for specific membrane layout requirements.
2. Due to the nature of mechanically attached roof systems, some fluttering or billowing of the membrane can be expected and may produce sound under certain conditions.
3. Firestone Batten Strips or Plates (appropriate for the system) must be used with Firestone fasteners to attach the Firestone roof system membrane.
4. Where the deck system will not provide a minimum fastener pullout resistance of 400 lb (1.8 kN), Firestone has designed a system of alternate fastener spacing to be used based on fastener pullout capacity.
5. Consult with local building, code and insurance officials or design professionals to determine if more stringent securements are required. Below is the minimum attachment requirement to receive a Firestone Warranty:

**TABLE 1.09-6
FASTENING RATES**

Min. Pullout Value	Fastener Spacing For Field	Fastener Spacing For Perimeter
1) 400 lbf or greater	12" o.c	12" o.c.
2) 300 lbf to 399 lbf	12"-6"-12" o.c.	12"-6"-12" o.c.
3) 200 lbf to 299 lbf	6" o.c.	6" o.c.
4) less than 200 lbf	This system is not applicable	

Min. Pullout Value	Fastener Spacing For Field	Fastener Spacing For Perimeter
1) 1.8 kN or greater	305 mm o.c	305 mm o.c.
2) 1.3 kN to 1.8kN	305-152-305 mm o.c.	305-152-305 mm o.c.
3) 0.9 kN to 1.3 kN	152 mm o.c.	152 mm o.c.
4) Less than 0.9 kN	This system is not applicable	

6. The fastener spacing in the above tables assumes that decking is dry and free of any deterioration. Firestone recommends that pullout testing be completed by the Firestone Licensed Applicator on all re-roof projects, regardless of deck type to confirm pullout resistance.
7. For decks other than those listed above, contact Firestone Roof System Solutions Group.



For retrofit of metal buildings, refer to the Metal Building Recover Design Guide. Direct attachment of Firestone Mechanically Attached roof systems to metals roofs (regardless of gauge) is strictly prohibited.

8. Perimeter Attachment Selection:
 - a) The Mechanically Attached Firestone roof system perimeter area must be attached in accordance with the Firestone Attachment Guide.
 - b) As an alternate to mechanical attachment, the perimeter area may be fully adhered.
 - (1) The area to be fully adhered must cover the same area as if the perimeters were mechanically attached, as indicated in the Firestone Attachment Guide.
 - (2) The perimeter area must be prepared in accordance with the substrate and insulation requirements of the Firestone Adhered roof system.
 - (3) The adhered perimeter area limit must be secured by and separated from the field of the roof by a continuous row of Firestone Batten Strips.

E. Membrane Lap Splicing (ReflexEON & UltraPly TPO Membrane up to 30-year Warranty)

1. Splice membrane by heat welding the side and end laps of thermoplastic membrane with a hot air welder.
2. If membrane thickness is greater than .045" (1.14 mm), T-joint patches must be installed at all intersections of field seams. Refer to Lap Splice Detail Section of this manual. For specific instructions, refer to Thermoplastic Single-Ply Application Guide.
3. Systems up to 20 Year warranty coverage may use ReflexEON or UltraPly TPO flashing with ReflexEON or UltraPly TPO QuickSeam products as appropriate. This detail must be finished off with a TPO QuickSeam T-Patch.
4. For a 20 or 25 year Red Shield Warranty. "T" joints must be sealed with Firestone membrane appropriate "T" Joint covers or unsupported flashing membrane.
5. For a 30-year Platinum Warranty. "T" joints must be sealed with respective Firestone ReflexEON "T" Joint or UltraPly TPO "T" Joint covers or unsupported flashing membrane
6. Refer to Firestone details regarding specific requirements.

F. Membrane Splicing (UltraPly TPO XR Membrane)

1. Splice membrane by heat welding the side and end butt of thermoplastic membrane with a hot air welder.
2. If membrane thickness is greater than .045" (1.14 mm), T-joint patches must be installed at all intersections of field seams. Refer to Lap Splice Detail Section of this manual. For specific instructions, refer to Single-Ply Application Guide.
 - a) Systems up to 20 Years may use UltraPly TPO flashing with UltraPly TPO QuickSeam. This detail must be finished off with a T-Patch.
 - b) UltraPly TPO: For a 20-year Red Shield Warranty. "T" joints must be sealed with Firestone UltraPly TPO "T" Joint covers or unsupported flashing membrane.
3. UltraPly TPO XR membranes side lap splicing is accomplished by welding the integral salvage edge to the adjacent sheet. In the absence of a salvage edge follow end splice procedure in #4.
4. End splices for up to 20-year Red Shield Warranty is done with a 8" (203.2 mm) strip of standard UltraPly TPO 96 or 120 membrane centered over the two, ¼" apart sheet ends and welded.

1.09 Flashings

A. Design considerations

1. Many factors affect the performance of the flashing system. Extended warranties may require special flashing applications and details. Design drawings for several common applications are available from the Firestone Technical Database Web Site. For additional assistance, contact Firestone Roof System Solutions Group.
2. A flashing is a roofing element used to prevent water from penetrating the exterior surface of a roof or to intercept and lead water off of it. Flashings divert the water to the membrane. The membrane then carries it to the roof drainage system. Typically a flashing intercepts water flowing down parapets, down walls of higher adjacent construction and down roof penetrations. There are four typical locations where a flashing is needed:
 - Terminations
 - Junctions
 - Projections
 - Joints

3. In any flashing detail, there are up to three different flashing components:

- Base flashing
- Counter-flashing
- Cap flashing

a) Base flashing

An extension of the roofing membrane or a different material that is bonded to the roof to form a waterproof joint. It extends upward along the vertical surface to divert water onto the membrane. The base flashing should reach a higher level than that reached by water on the roof. In some situations, water may have to be temporarily stored on the roof. This may occur during heavy rainfalls, where the drain size is inadequate, where local building regulations require controlled flow drains, or where ice and snow restrict drainage.

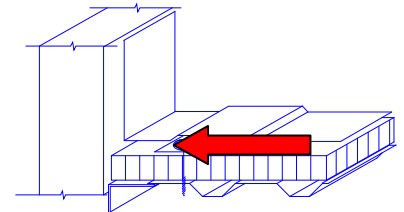

b) Counter-flashing

Counter-flashing is used, in some situations, to carry water onto the base flashing and the membrane. This may be the case where a wall rises above a roof surface. The counter flashing covers the vertical face of the base flashing. It provides protection for the base flashing and may serve to shed water. Where required, the counter-flashing is secured to the parapet or wall cladding.

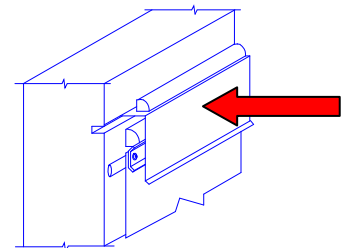

c) Cap flashing

Cap flashings are horizontal coverings for parapets and expansion joints. Cap flashing should be sloped toward the roof and secured to allow differential movement. Failure to provide for adequate flashing height at the design stage may result in serious problems that cannot be corrected subsequently.

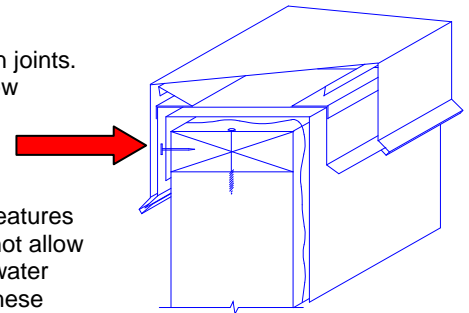

4. Limitations in flashing heights may be encountered. Existing building features (i.e., door or window locations, weeps or through-wall flashings) may not allow sufficient clearance to provide proper termination above the potential water level, additional insulation or other details. Detailed consideration of these conditions is critical to the integrity of the roofing system.

B. Wall/Curb Flashing Materials and Requirements

1. The following is a chart listing the flashing requirements for Firestone single-ply systems.
2. Refer to the Single-Ply Application Guide and detail drawings sections.
3. 25 and 30-year warranties may require special flashing applications.
4. All membrane base tie-ins must be attached to substrates which provide a minimum of 200 lbf (89 kN) force.

**TABLE 1.10-1
WALL/CURB FLASHING MATERIALS AND REQUIREMENTS**

	Detail	Detail Description		
ReflexEON & UltraPly Platinum .080" TPO Membranes	Wall Terminations	Firestone Termination Bar with AP Sealant applied along the caulk ledge and finished with a surface mounted or inserted counter flashings are to be used in accordance with current Firestone details.		
	Curbs	Curbs, longer than eight (8) feet on any side and expansion joints must be anchored using QuickSeam RPF Strip. Curbs must be flashed using minimum .060 UltraPly membrane.		
	Corners	Flashed using corner flashing and Inside/Outside corners		
	Roof Edges	5- 20 year	Any Firestone edge metal system, including contractor-fabricated Firestone metal installed in accordance with current Firestone details. As an alternate, QuickSeam 5" Flashing over ANSI/SPRI ES-1 rated metal edge, may also be used.	
		25 and 30-year	Firestone factory-fabricated metal edge system (AnchorGard, EdgeGard, or Firestone Coping). As an alternate, welded Firestone TPO coated metal Flashing over ANSI/SPRI ES-1 rated metal edge detail, may also be used.	
	Parapets	Firestone Coping System		
Penetrations	Flashed using QuickSeam Pipe Flashing, QuickSeam Penetration Pocket or per Firestone Details.			
ReflexEON & UltraPly TPO	All	5 – 20 year	Flashings may be sealed with TPO QuickSeam or by heat welding. Use standard UltraPly details. QuickSeam Primer required when using QuickSeam Flashing. Details may include TPO coated metal.	
		25 year	.060" Flashings may be sealed with Welded Details only. Details may include TPO coated metal.	
	Roof Edges	5- 20 year	Any Firestone edge metal system, including contractor-fabricated Firestone metal installed in accordance with current Firestone details As an alternate, QuickSeam 5" Flashing over ANSI/SPRI ES-1 rated metal edge, may also be used	
		25 year	Firestone factory-fabricated metal edge system (AnchorGard, EdgeGard, or Firestone Coping). As an alternate, welded Firestone TPO coated metal Flashing over ANSI/SPRI ES-1 rated metal edge detail, may also be used.	
	Parapets	Firestone Coping System		
UltraPly TPO XR	All	5- 20 year	Flashings may be sealed with TPO QuickSeam or by heat welding. Use standard UltraPly TPO details QuickSeam Primer required when using QuickSeam Flashing	
		25 year	UltraPly TPO XR 115 or standard UltraPly TPO, Welded Details only.	
	Roof Edges	5- 20 year	Any Firestone edge metal system, including contractor-fabricated Firestone metal installed in accordance with current Firestone details As an alternate, QuickSeam 5" Flashing over ANSI/SPRI ES-1 rated metal edge, may also be used	
		25-year	Firestone factory-fabricated metal edge system (AnchorGard, EdgeGard, or Firestone Coping). As an alternate, welded Firestone TPO coated metal Flashing over ANSI/SPRI ES-1 rated metal edge detail, may also be used.	
	Parapets	Firestone Coping System		

C. Penetrations (Pipes, Conduits, Etc.)

1. Pipe Flashings:
 - a) Whenever possible, all round rigid pipe penetrations ranging in size from 1" (25.4 mm) outside diameter to 6 ½" (165 mm) outside diameter should be flashed with Firestone Pre-molded Pipe Flashings. If it is not possible to fit a Pre-Molded Pipe/Conduit Flashing or Firestone Quickseam Flashing onto the pipe due to site conditions, the pipe should be covered with a field-fabricated flashing in accordance with Firestone Details.
2. Flexible penetration (electrical and braided cable, etc.):
 - a) Pre-molded and field-fabricated flashing must not be installed around flexible pipes or conduits. Flexible penetrations must be installed in a sheet metal gooseneck or other boxed out structure.

D. Penetration Pockets:

1. The following types of penetrations require the installation of a Firestone Penetration Pocket where ever possible:
 - a) Rigid pipes with an outside diameter less than 1" (25.4 mm) and up to 4" (102 mm).
 - b) Clusters of pipes.
 - c) Unusual shapes, e.g., structural beams, channels or angles.
2. A minimum clearance of 1" (25.4 mm) between penetrations, pipes, conduits, etc., and on all sides of the penetration pocket, is required to assure adequate space for the application of Single Ply QuickPrime Primer or UltraPly TPO QuickPrime LVOC Primer and Pourable Sealer around each penetration.

E. Curbs and Terminations:

1. All flashing terminations above the field of the roof membrane (except penetration pockets and Pre-Molded Firestone roof system Pipe Flashings) should provide a minimum design height of at least 8" (203.2 mm).
2. Minimum flashing height should be no lower than the potential water level that could be reached as a result of a deluging rain. Wherever a vertical termination height is 5" (127 mm) or less, a termination detail using a Firestone Termination Bar, that is subsequently counterflashed, is required. Do not flash over existing through-wall flashings, weep holes, scuppers and overflow scuppers.
3. Terminations must be made directly to a sound, watertight, rigid, vertical substrate. For retrofit conditions, existing loose flashing materials must be removed, or overlaid with 5/8" exterior grade plywood. Termination bars are not acceptable directly to gypsum or wooden substrates.
4. When using a surface-mounted termination, (i.e., termination bar, surface-mounted counterflashing) ensure a consistent seal at the wall interface. The surface above the termination must be waterproof.
5. Gypsum board, used as a substrate for flashings, must be moisture resistant exterior grade with laminated fiberglass facers and recommended for this application by the gypsum board manufacturer. Base tie-ins must be made into the deck because gypsum does not provide the required minimum fastener pullout resistance of 200 lbf (0.9 kN).
6. Stucco, cobblestone, textured masonry, corrugated metal panes or any uneven surface is not a suitable substrate to receive flashing. Such surfaces must be prepared to provide an acceptable substrate by attaching minimum 5/8" (15.8 mm) exterior grade or pressure treated plywood. Attach as required for structural integrity.
7. DensGlas Gold is not an acceptable substrate for any Firestone membrane wall flashing system.

F. Sheet Metal Work

1. Coping, gravel stops, Drain bars, counterflashings etc., must be supplied by Firestone. If Firestone is not able to supply a given sheet metal product or design, it must be installed per current Firestone details but will not included as part of the warranty.
2. It is the owner's responsibility to maintain non-Firestone sheet metal in a watertight condition.
3. Make these specifications available to the sheet metal fabricator/contractor.

4. Attachment
 - a) Counterflashings, copings, and other perimeter or penetration metal work must be properly fastened and sealed by the roofing contractor or others.
 - b) All sheet metal work not supplied by Firestone should be fabricated and installed in accordance with the most stringent requirements from one of the following organizations, The Sheet Metal and Air Conditioning Contractors National Association, Inc. (SMACNA), National Roofing Contractors Association (NRCA), ANSI/SPRI or Dade County.



Some specific roofing details in Firestone's Technical Specifications may exceed SMACNA recommendations. For such details, the Firestone requirements must be used.

Refer to ANSI/SPRI ES-1 for information on wind design information for metal edge treatments and performance criteria.

Extended wind speed warranties require enhanced edge details. Contact Firestone Roof System Solutions Group at Firestone for specific information.

5. All sheet metal work not supplied by Firestone should have a quality weather resistant coating that will not corrode or weather to the point of failure during the warranty period.
6. Metal work not in conformance with Firestone specifications and details or which compromises the integrity of the roof system may jeopardize issuance of the warranty for the entire project. Firestone does not warrant the performance of products Firestone does not supply.
7. UltraPly TPO may require the specific use of TPO coated metal.
8. UltraPly TPO XR requires special considerations, see specific details or contact your Firestone Technical Coordinator.

1.10 Walkways

A. Locations

1. Walkway systems must be installed on roofs:
 - Subjected to traffic more frequently than once per month
 - At all access points (ladders, hatches, doorways, etc.) to the roof
 - Around all serviceable rooftop units
2. If protection of the insulation system is required, additional measures must be specified (i.e., concrete pavers, pre-fabricated/elevated walkways).
3. The owner is responsible for maintaining walkways.

B. Walkway Material

1. For Thermoplastic single-ply systems, Firestone UltraPly TPO Premium Walkway Pads or X-Tred Walkway Pads are to be utilized in the areas indicated above. Each pad is to be installed in accordance with the installation instructions provided in the Technical Information Sheet for each product.
2. Firestone Red Shield Support System offers an engineered walkway system.
3. Walkways may be constructed using Firestone UltraPly TPO Premium Walkway Pads, X-Tred Walkway Pads or Pavers with sacrificial membrane layer.
4. Concrete pavers, with an additional layer of membrane installed beneath the paver for protection, may be substituted for walkway pads on ballasted and adhered systems. Consult details.
5. Special Requirements for Ballasted Systems: Walkways within 10' (3.04 m) of the edge of the roof must be concrete pavers over an additional layer of membrane.
6. Contact your Firestone Technical Coordinator regarding other materials designated as a walking surface.

1.11 Warranty

A. General

1. Consult this Single Ply Design Guide opening section: 1.01 General Design Criteria initial Design Considerations and Warranty requirements.
2. For all 30 year ReflexEON Platinum or UltraPly Platinum systems the installation must be either new or a complete tear off for all existing roofing. Any damaged roof system components must be repaired or replaced.
3. For new and replacement roofing, Firestone HD fasteners, or Polymer fasteners, if required, must be used for a 25 or 20 year Red Shield Warranty, when mechanically fastening insulation using fasteners and plates.
4. For Retrofit roof systems, Firestone HD fasteners, or Polymer fasteners, if required must be used for 15 -year or greater warranty, when mechanically fastening insulation using fasteners and plates.
5. Firestone roof system tie-ins to other roofing systems are not warranted by Firestone.
6. Failure of a flashing terminated to an intermediate element (e.g., metal flashing, insulation, surface treatment, etc.), which itself could fail and admit moisture beneath the membrane is beyond the limits of the Firestone warranty.

Upon Firestone's inspection and acceptance of the installed roof system, the requested warranty can be issued. Firestone's inspection is not intended as an inspection for benefit of the owner or design professional with respect to contract, building codes or compliance with specifications other than Firestone's. Warranted Firestone roof systems are to be installed only on commercial, industrial, institutional or multi-family commercial housing buildings in the United States and Canada. Issuance of a warranty for projects outside the US and Canada must be submitted to your Firestone Technical Coordinator for consideration prior to bidding. Individual residential construction does not qualify for a Firestone warranty. Only Firestone-supplied components are eligible to be covered as part of the Firestone Warranty.

**TABLE 1.12-1
MAXIMUM WARRANTY TERM THERMOPLASTIC SYSTEMS**

Thickness	Membrane	5-15 Year	20-Year	25-year	30-year
.080" (2.0mm)	ReflexEON Platinum UltraPly Platinum	YES	YES	YES	YES
.060" (1.52mm)	ReflexEON & UltraPly	YES	YES	YES	NO
.045" (1.14mm)	UltraPly TPO	YES	YES	NO	NO
.060" (1.52mm)	UltraPly TPO XR 115	YES	YES	NO	NO
.045" (1.14mm)	UltraPly TPO XR 100	YES	NO	NO	NO
.060" (1.52mm)	UltraPly TPO SA	YES	YES	YES	NO
.045" (1.14mm)	UltraPly TPO SA	YES	YES	NO	NO

7. It is the owner's responsibility to expose the membrane in the event that warranty service is required when access is impaired. Such impairment includes, but is not limited to:
 - Design features, such as window washer systems, which require the installation of traffic surface units in excess of 80 lb (36.3 kg) per unit
 - Any equipment, ornamentation, building service units and other roof top surfacing materials that are not defined as part of the membrane assembly
 - Intricately placed or multicolored ballast configurations
 - Individual pavers utilized as ballast, which weigh more than 80 lb (36.3 kg) per unit, unless otherwise required by Firestone for wind uplift resistance

- Interlocking paver systems that utilize mechanical clips, strapping, adhesive, etc.
- Rooftop equipment that does not provide Firestone with reasonable access to the membrane
- Severely ponded water, snow, ice, and other unrelated materials

The following charts show the types and minimum thickness of Firestone insulation acceptable for use as an immediate substrate for Firestone roof membranes in Firestone Red Shield warranties. Other approved insulations may be allowed below the immediate substrate insulation.

**TABLE 1.12-2
ACCEPTABLE INSULATIONS (IMMEDIATE SUBSTRATE) FOR SINGLE-PLY MEMBRANES**

System		Firestone ISO 95+ GL (flat or tapered)	Firestone Resista	Firestone HailGard	Firestone FiberTop	Firestone ISOGARD HD	DensDeck®* Products
The minimum thickness of Firestone insulation acceptable for use as an immediate substrate for Firestone roof system.		1.0" (25.4 mm)	1.0" (25.4 mm)	1.5" (38.1 mm)	½" (12.7 mm)	0.5" or 1.0" (12.7 or 25.4 mm)	¼" (6.3 mm)
Adhered		✓	✓	✓	✓	✓	✓
Ballasted		✓	✓	N/A	✓	N/A	N/A
Mechanically Attached		✓	✓	✓	✓	✓	✓
UltraPly TPO XR	Hot Asphalt	N/A	N/A	N/A	✓	N/A	✓
	XR Bonding Adhesive	N/A	N/A	✓	✓	✓	✓
	I.S.O Spray S Adhesive	✓	✓	✓	✓	✓	✓
	XR Stick	✓	✓	✓	✓	✓	✓
✓ =Acceptable							

NOTE: This chart is only a summary of the general warranty coverage.

**TABLE 1.12-3
ACCEPTABLE INSULATIONS FOR SINGLE-PLY MEMBRANES
20 or 25-Year Firestone Red Shield Warranties**

The minimum thickness of Firestone insulation acceptable for use as an immediate substrate for Firestone roof membranes in Firestone Red Shield warranties.

System		Firestone ISO 95+ (flat or tapered)	Firestone Resista	Firestone HailGard	Firestone FiberTop	Firestone ISOGARD HD	DensDeck®* Products
The minimum thickness of Firestone insulation acceptable for use as an immediate substrate for Firestone roof system.		1.0" (25.4 mm)	1.0" (25.4 mm)	1.5" (38.1 mm)	½" (12.7 mm)	1/2" or 1" (12.7 or 25.4mm)	¼" (6.3 mm)
Adhered		✓	✓	✓	N/A	✓	✓
Ballasted		✓	✓	N/A	N/A	N/A	N/A
Mechanically Attached		✓	✓	✓	N/A	✓	✓
UltraPly TPO XR	Hot Asphalt	N/A	N/A	N/A	N/A	N/A	✓
	I.S.O Spray S Adhesive	✓	✓	✓	✓	✓	✓
	XR Stick	✓	✓	✓	✓	✓	✓
	XR Bonding Adhesive	N/A	N/A	✓	N/A	N/A	✓
✓ =Acceptable							

* DensDeck® is a registered trademark of Georgia-Pacific Gypsum, LLC. Please consult www.gpsypsum.com for roofing systems application recommendations and guidelines.

TABLE 1.12-4
.080" ReflexEON Platinum & UltraPly Platinum
System Design Options & Requirements

	Basic Platinum	Puncture (P)	Puncture & Hail (PH)	Puncture & Wind (100 mph) (PW)	Puncture, Hail & Wind (PHW)
System Securement					
Wide Weld (Mech. Att. Battens)	✓			✓	
Fully Adhered (8' & 10' sheets w/5" Wide Weld Seams)	✓	✓	✓	✓	✓
Minimum Insulation					
ISO 95+ GL (1" minimum req.)	✓	✓		✓ (Mech. Att. 5' and 8' sheets Only)	
HailGard (1-1/2" minimum req.)	✓	✓	✓	✓	✓ (Fully Adhered Only)
ISOGARD HD (1/2" or 1")	✓	✓		✓ (Mech. Att. 5' and 8' sheets Only)	
Resista	✓	✓		✓ (Mech. Att. 5' and 8' sheets Only)	
DensDeck (¼" minimum req.)	✓	✓		✓ (Mech. Att. 5' and 8' sheets Only)	
Insulation Fastening					
HD Fasteners & Insulation Plates (Iso 95+ & DensDeck only)	✓	✓	✓	✓	
I.S.O. TwinPack or I.S.O.Stick	✓	✓	✓		
I.S.O. Fix	✓	✓	✓		
I.S.O SPRAY S	✓	✓	✓		
HailGard Fasteners (HailGard Only)	✓	✓	✓	✓	✓ (Fully Adhered Only)
Membrane Fastening					
Standard Specification (72 -90 mph Contact your Firestone Technical Coordinator)	✓	✓	✓		
100 mph Wind Design (Contact your Firestone Technical Coordinator for Review)				✓	✓
Roof Edge					
AnchorGuard (complet system)	✓	✓	✓	✓	✓
AnchorGuard (with field fab Una-Clad MetalOnly)	✓	✓	✓		
EdgeGuard+ (complete system only)	✓	✓	✓		
Firestone Coping (complete system	Una-Clad			✓	✓
✓ =Acceptable					

**TABLE 1.12-5
WALL/CURB FLASHING MATERIALS AND REQUIREMENTS**

WARRANTY TERM			
Single-Ply System	5, 10, and 15-Year	20 or 25-Year	30-Year
ReflexEON Platinum .080" (2.0 mm) & UltraPly Platinum .080" (2.0 mm)	One ply of ReflexEON or UltraPly TPO .080" or .060" membrane or membrane coated metal, consult details		
ReflexEON .060" (1.52 mm) UltraPly TPO .060" (1.52mm) TPO XR 115 .060" (1.52mm)	One ply of ReflexEON or UltraPly TPO minimum .060" membrane or membrane coated metal, consult details.		N/A
UltraPly TPO .045" (1.14mm) UltraPly TPO XR 100 .045" (1.14mm)	One ply of UltraPly TPO minimum .045" membrane or membrane coated metal, consult details.		N/A
UltraBlend*	.060" (1.52mm) Fully Adhered RubberGard EPDM or EcoWhite Membrane seamed to TPO with QuickSeam splice tape products. (up to 20 year only)		N/A
UltraPly TPO SA .045" (1.14mm)	.045" (1.14mm) Adhered TPO SA Membrane with heat welded seams (up to 20 year only)		N/A
UltraPly TPO SA .060" (1.52mm)	.060" (1.52mm) Adhered TPO SA Membrane with heat welded seams (up to 20 year only)		N/A
N/A = Not Applicable			

* UltraBlend refers to a system with TPO membrane in the field of the roof and RubberGard EPDM or EcoWhite EPDM membrane and/or QuickSeam products used as the wall/curb flashing materials.

**TABLE 1.12-6
FIRESTONE THERMOPLASTIC WARRANTY SUMMARY**

WARRANTY NAME	SPECIFICATION	ELIGIBLE CONTRACTOR	COVERAGE
Platinum PHW Puncture Hail and Wind	Firestone 80mil Platinum membrane, fully adhered to HailGard insulation	Red Shield	Repair leaks in the roof system caused by Firestone-supplied materials or the workmanship used to install them plus damage by puncture, hail, or winds up to 100 mph. No dollar limit to Firestone expenditures to honor the warranty. Warranty term: 30-years
Platinum PW Puncture and Wind	Firestone 80mil Platinum membrane, fully adhered to HailGard insulation or 8' sheets Mechanically Attached	Red Shield	Repair leaks in the roof system caused by Firestone-supplied materials or the workmanship used to install them plus damage by puncture or winds up to 100 mph. No dollar limit to Firestone expenditures to honor the warranty. Warranty term: 30-years
Platinum PH Puncture and Hail	Firestone 80mil Platinum membrane, fully adhered to HailGard or Dens-Deck, installed over ISO 95+ GL insulation	Red Shield	Repair leaks in the roof system caused by Firestone-supplied materials or the workmanship used to install them plus damage by puncture or hail. No dollar limit to Firestone expenditures to honor the warranty. Warranty term: 30-years
Platinum P Puncture	Firestone 80mil Platinum membrane, fully adhered to ISO 95+ GL insulation	Red Shield	Repair leaks in the roof system caused by Firestone-supplied materials or the workmanship used to install them plus damage by puncture. No dollar limit to Firestone expenditures to honor the warranty.

			Warranty term: 30-years
Platinum	Firestone 80mil Platinum membrane, fully adhered to ISO 95+ GL insulation	Red Shield	Repair leaks in the roof system caused by Firestone-supplied materials or the workmanship used to install them. No dollar limit to Firestone expenditures to honor the warranty. Warranty term: 30-years
White AcryliTop PC-100 Reflectance Warranty	Firestone 80mil Platinum EPDM, specifications for the term of 5 Year from date of installation	Red Shield	Provide the owner with replacement AcryliTop PC-100 Coating to repair the affected area should the reflectance rating fall below .50
AcryliTop PC-100 Coating Limited Warranty	Firestone 80mil Platinum EPDM or Thermoplastic specifications for the term requested	Red Shield	Provide the owner with replacement AcryliTop PC-100 Coating to repair the area should the coating come loose. Warranty term: Up to 10-years
Red Shield Limited Warranty	Firestone Thermoplastic specifications for the term requested	Red Shield	Repair leaks in the roofing system caused by Firestone-supplied materials or the workmanship used to install them. No dollar limit to Firestone expenditures to honor the warranty.
WARRANTY NAME	SPECIFICATION	ELIGIBLE CONTRACTOR	COVERAGE
Membrane-Only Warranty	Firestone Thermoplastic specifications for the term requested	Red Shield	Provide replacement membrane materials sufficient to replace any area of Firestone Roofing Membrane ("Membrane") which leaks as a result of ordinary exposure to the elements or any manufacturing defect in the Membrane. Prorated
Up to 20 Year Manufacturer's Insulation Warranty	Firestone Thermoplastic specifications for the term requested	Red Shield	Provide owner with free Firestone ISO 95+ to repair the affected roof area if the Firestone ISO 95+ warps, bows or destabilizes to the point of causing a roof leak as a result of any manufacturing defect in the ISO 95+
Up to 15 Year ISO 95+ Thermal Insulation Warranty	Firestone Thermoplastic specifications for the term requested	Red Shield	Provide replacement insulation should the Firestone ISO 95+ GL fail to retain 80% of its published R-value

This chart is only a summary of the general warranty coverage.

END OF SECTION