



FIVE STAR PRODUCTS, INC.

FiveStarProducts.com
(800) 243-2206

DESIGN-A-SPEC™ GUIDELINES FIVE STAR® FLUID GROUT 100

CONTENTS

▶	PART A - GENERAL CONDITIONS
▶	PART B - MATERIAL SPECIFICATIONS
▶	PART C - PREPARATION
▶	PART D - APPLICATION
▶	PART E - FINISHING AND CURING
▶	PART F - EXTREME WEATHER CONDITIONS

This document is provided for informational purposes only and as a general guideline for consideration by contractors and engineers. While every reasonable effort has been made to ensure that this information is accurate and authoritative, Five Star Products does not warrant the accuracy or completeness of this information, or for its appropriateness for any particular purpose. The user of this document remains solely responsible for the specification of all methods, materials and practices.

PART A - GENERAL CONDITIONS - CEMENTITIOUS GROUTING

1.01 SCOPE

The work covered by this document consists of furnishing all equipment, materials, labor and performing all operations required for the installation of precision nonshrink grouts as directed by the engineer or owner.

1.02 QUALITY ASSURANCE

- A. The manufacturer shall have been in the business of manufacturing similar products for over ten years, maintain a strict quality assurance program, offer technical services and provide a representative at the jobsite for product training, prior to product installation, upon written request.
- B. The contractor shall submit to the engineer or owner, at least three job references where the contractor has successfully completed similar applications.

1.03 DELIVERY, STORAGE AND HANDLING

- A. All materials shall be delivered to the jobsite in their original, unopened packages, clearly labeled with the manufacturer's identification, printed instructions and batch code.
- B. Store and condition the specified product in accordance with the appropriate product data sheet.
- C. For handling instructions, refer to the Material Safety Data Sheet.

1.04 PROJECT/SITE CONDITIONS

Refer to PART C - PREPARATION, ENVIRONMENTAL CONDITIONS, or contact the manufacturer directly for any physical or environmental limitations required by the product.

1.05 MEASUREMENT AND PAYMENT

- A. Measurement of the grouting work shall be on a cubic foot (liter) basis of material in place.
- B. Payment for the grouting work shall be at the unit price bid on a cubic foot (liter) basis. This payment shall constitute full compensation for all labor, materials, tools, equipment and other items as necessary to complete the work as described in the contract documents. Progress payments will be made on the percentage of the work satisfactorily completed during each payment period in accordance with the provisions of the contract documents.

PART B - MATERIAL SPECIFICATION - CEMENTITIOUS GROUT**2.01 MATERIALS**

- A. Nonshrink cementitious grout shall be a fluid consistency, pre-packaged, cement-based grout requiring only the addition of potable water. The manufacturer shall be ISO 9001 certified and have at least 10 years experience in the manufacture of precision cement-based grouts. The manufacturer shall offer technical services and provide a representative at the jobsite for product training prior to product installation upon five days advance notice.
- B. The grout material shall meet all the following typical performance criteria when cured at 73°F (23°C):
1. Grout shall not contain metallic aggregate, expansive cement, or gas generating additives such as aluminum powder.
 2. Grout shall contain an air release aggregate to generate positive expansion.
 3. Early Height Change, ASTM C 827 0.0 to 4.0%
 4. Hardened Height Change, ASTM C 1090 0.0 to 0.3%
 5. Effective Bearing Area 95%
 6. Compressive Strength, ASTM C 942

1 Day	3500 psi
7 Days	6500 psi
28 Days	8000 psi
 7. Bond Strength, ASTM C 882

28 Days	2000 psi (13.8 MPa)
---------	---------------------
 8. Consistency, ASTM C 939 20 – 30 seconds
 9. Working Time 30 minutes
 10. Application Temperature 40°F to 90°F (4°C to 32°C)
 11. Material Temperature 40°F to 90°F (4°C to 32°C)
 12. Meets performance requirements of ASTM C 1107-02, Grades A, B and C for 30 minutes at 40°F to 90°F (4°C to 32°C).
 13. Freeze Thaw Resistance ASTM C 666A 300 Cycles (less than 2% weight loss)

The data shown above reflect typical results based on laboratory testing under controlled conditions. Reasonable variations from the data shown above may result in the field. Test methods are modified where applicable.

- C. An acceptable product which meets these criteria is:

Five Star® Fluid Grout 100

As manufactured by Five Star Products, Inc., Shelton, CT 06824 (203) 336-7900.

- D. Subject to meeting the performance criteria stated above, other products may be formally submitted to the engineer for approval up to three days prior to the bid date. All requests for approval shall contain certified test data verifying conformance with this specification. Three references of successfully completed projects of similar nature and scope of the work detailed in this specification shall be provided, as well as a minimum ten year history of use in the industry. The testing laboratory shall certify to any modifications made to tests performed and provide details of modifications.

2.02 CLEARANCES

- A. For placement thicknesses less than one-half inch (13 mm) or greater than six inches (150 mm), contact the manufacturer. For depths greater than six inches (150 mm) refer to Aggregate Extension Section 2.03

2.03 AGGREGATE EXTENSION

- A. The grout may be used for preplaced aggregate grouting as stated in ACI Concrete Practice 304.1R-92. Aggregate should be a single size and a sample shall be submitted for approval.
- B. For pours greater than six inches (150 mm) in depth, the grout may be extended by the addition of clean, damp coarse aggregate according to the following guidelines:

<u>Depth of Pour</u> Inches (mm)	<u>Typical Extension</u> (Percentage by wt.)
6 + to 9 (150 – 225)	35% - 50%
9 + to 12 (225 – 350)	50% - 60%
12 + to 18 (225 – 450)	60% - 80%
18 + (450 +)	Contact Five Star

Coarse aggregate shall be clean and washed and conform to the requirements of ASTM C 33. Fluid consistency grouts should be mixed at less than fluid consistency (flowable) when extending with coarse aggregate.

PART C – PREPARATION - CEMENTITIOUS GROUTING

3.01 CONCRETE SURFACES

- A. Completely remove all loose, delaminated and weak concrete, oil, grease, laitance and other contaminants. Prepare concrete using acceptable mechanical means and concrete cleaners and degreasers as necessary to obtain clean, sound and rough concrete surfaces exposing coarse aggregate. A Concrete Surface Profile (CSP) of 8-10 in accordance with ICRI Technical Guideline 210.2R is recommended. Blow surfaces free of dust and debris using oil-free compressed air.
- B. Prior to placement, soak concrete surfaces thoroughly for a minimum of eight hours to an optimum 24 hours with potable water. Concrete shall be saturated and free of standing water at time of placement.

3.02 METAL SURFACES

- A. Where bond to metal surfaces is not required, coat with a bond breaker such as paste wax or duct tape.
- B. Where bond to metal surfaces is required, the surface shall be clean, free of oil, grease, rust and other contaminants. Sandblasting to a SSPC-SP6* commercial finish will optimize bond development of grout to steel.
- C. Provide 1/4 to 1/2 inch (6 to 12 mm) air relief holes where baseplate configuration and high spots will entrap air.
- D. When grouting skid mounted equipment or frames, provide a four to six inch diameter (100 to 150 mm) grout filling hole in the center of each bulkhead section.

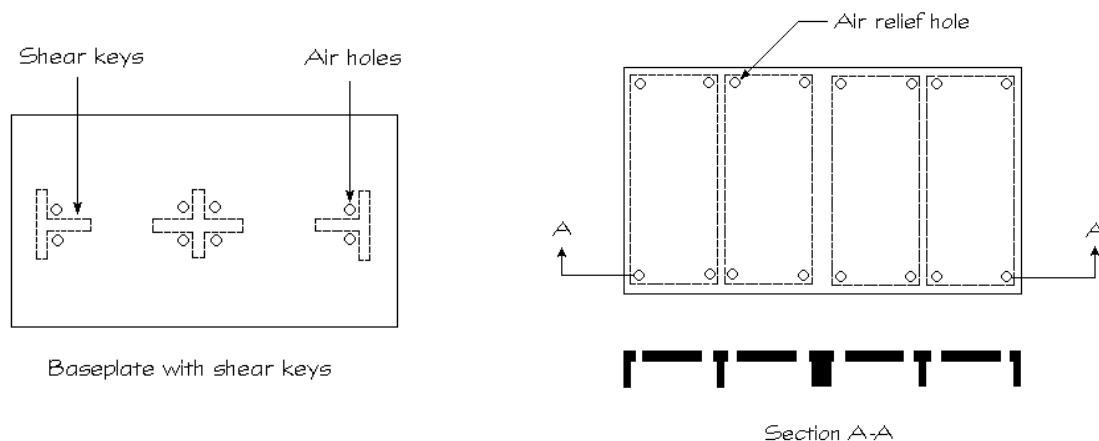

***SSPC-SP6**

Commercial blast cleaned surface is defined as one in which all oil, grease, dirt, mill scale, rust and old paint have been completely removed from the blast cleaned surface, except that slight streaks, or discolorations caused by rust stain, mill scale oxides, or slight tightly adherent residues of paint or coating may remain. If the surface is pitted, slight residues of rust or paint may remain in the bottom of the pits. The slight discolorations mentioned above are limited to one-third of every square inch.

3.03 FORMWORK

- A. Formwork shall be constructed of rigid nonabsorbent materials, securely anchored, watertight and strong enough to resist forces developed during grout placement.
- B. Formwork shall be constructed so that the grout is placed across the shortest distance whenever possible. The clearance between formwork and baseplate shall be sufficient to allow for headbox. The clearance for remaining sides shall be one to three inches (25 to 75 mm).
- C. Height of formwork shall extend a minimum of one inch (25 mm) above the bottom of the baseplate.
- D. All formwork shall be coated with a form release agent. Caution: Care should be taken not to contaminate grouting surfaces where bond is required.

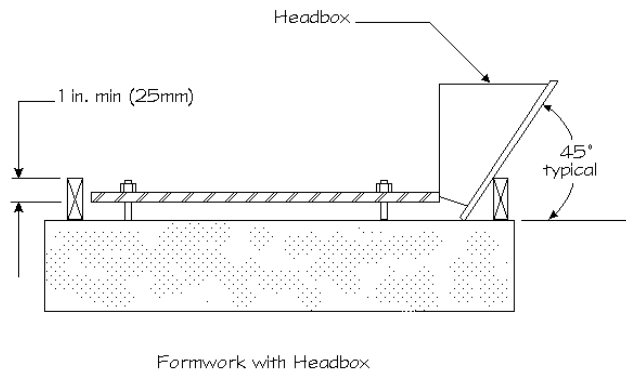

3.04 ENVIRONMENTAL CONDITIONS

- A. Condition and maintain all materials and surfaces that contact grout to between 40°F and 90°F (4°C and 32°C). Shade from direct sunlight as necessary.
[For detailed conditioning procedures for Cold Weather or Hot Weather Grouting, refer to PART F – EXTREME WEATHER CONDITIONS.]

3.05 CLEARANCES/EXTENSION

- A. All plates shall be set to final alignment before grouting using leveling devices such as shim packs, wedges, leveling nuts or jack screws. When shims and wedges are to remain in place, distance from edge of plate shall be a minimum of two inches (50 mm). Provide a minimum radius of two inches (50 mm) on all corners of shims and wedges.

[Clearances beneath baseplates are dependent on specified product, environmental conditions, obstructions and flow distance.]

[For pours greater than 6 inches (150 mm), coarse aggregate extension may be required. Refer to manufacturers' recommendations.]

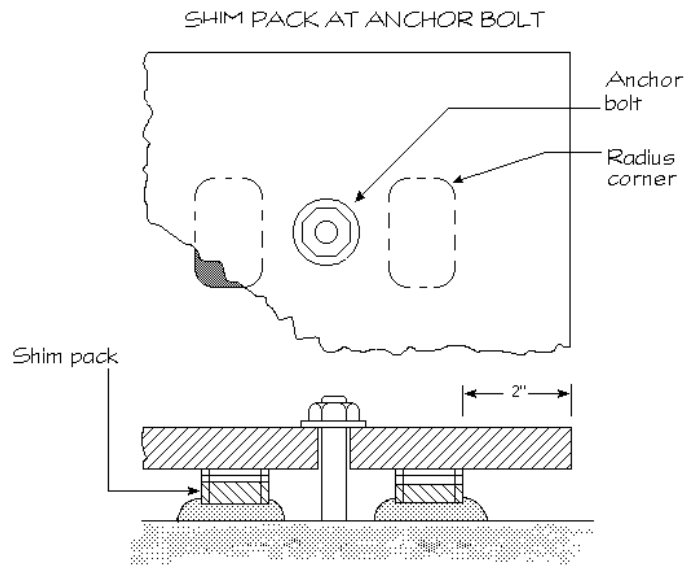

TYPICAL JACK SCREW DETAIL

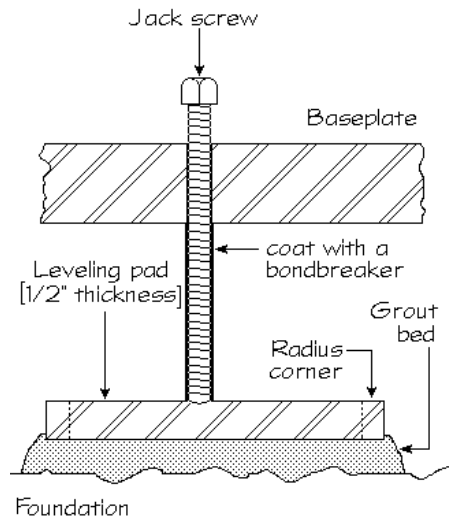

3.06 EQUIPMENT AND MATERIALS

- A. All necessary tools, equipment and materials shall be as close as possible to the area being grouted, such as mortar mixers, measuring containers, trowels and grout.
- B. Appropriate clothing and safety equipment shall be worn to avoid breathing dust and prevent eye and skin contact with both dry and mixed grout.
- C. Wheelbarrows, buckets, shovels and pumps shall be clean, dampened and readily available for transporting mixed grout.
- D. Provide headbox and plunger when pouring grout. Provide backboard, ram and hammer when dry-pack grouting.
- E. An ample source of potable water shall be available for preconditioning, mixing, cleaning and curing.

3.07 MIXING

[Select one of the following types of mixers, as appropriate.]

Mortar Mixer (Stationary Barrel with Moving Paddles)

- A. Provide necessary number of mortar mixers in good operating condition for uninterrupted placement. Mix enough grout to utilize one-half the maximum capacity of the mortar mixer.
- B. Pre-wet mortar mixer, empty excess water.
- C. Begin by mixing grout with 4.5 quarts potable water with 55 lb. bag. Mix for approximately two minutes. Add an additional 0.5 to 1.0 quarts and continue mixing for three minutes.
- D. If a fluid consistency is required, typically around 5½ quarts water (total) will allow for a fluid consistency.
- E. Do not mix more material than can be placed within the working time of the grout (30 minutes at 70°F). Do not retemper the mix by adding additional water.
- F. Transport mixed material by wheelbarrow or buckets, taking care not to allow material to segregate.
- G. For pours requiring aggregate extension, add clean, damp coarse aggregate meeting the requirements of ASTM C 33 before final water adjustment.

Ready-Mix Concrete Truck – Bulk Bags + Coarse Aggregate Extension

- A. **Verify working time of grout and water requirements under jobsite conditions before placement in concrete truck. CONTACT FIVE STAR PRODUCTS BEFORE COMMENCING WORK VIA READY MIX TRUCKS.**
- B. Mixing drum and mixing blades must be in good operating condition, predampened and excess water removed.
- C. First add clean, damp, coarse aggregate meeting the requirements of ASTM C 33 to drum.
- D. Add approximately 75% of premeasured potable water to mixing drum as predetermined by testing. Five gallons of this 75% shall be held back for hopper wash down. Water addition must be adjusted if wet aggregate is used or water is present in the drum.
- E. Add grout, with drum turning at a slow speed. Do not exceed half the capacity of drum or add more than 3 bulk bags per truck. Use the 5 gallons (19 liters) of held back water to wash down hopper and drum after loading. Mix thoroughly for approximately five minutes at slow speed to a uniform consistency.
- F. Reverse drum to check consistency. Add remaining water as needed, then mix to a uniform consistency. Do not exceed maximum allowable water content as stated on product packaging or add an amount that will cause segregation. Small bags of grout should be available to stiffen consistency if necessary.
- G. Position truck as close as possible to pour and promptly discharge from truck. When transporting mixed grout, take care not to allow grout to segregate.

REFERENCES

ACI 351.1R-99

“Grouting Between Foundations and Bases for Support of Equipment and Machinery”

PCA 1990

“Cementitious Grouts and Grouting”

PART D – APPLICATION - CEMENTITIOUS GROUTING

4.01 PLACEMENT PROCEDURES

POURING

- A. A headbox or similar device is required for a continuous pour to avoid air pockets under baseplate. All grouting shall take place from one side to the other, maintaining contact with the bottom of the plate at all times, maximizing effective bearing area (EBA).
- B. When pouring through grout holes, placement shall proceed continuously with a headbox until the grout has risen in the next hole. Maintain head pressure at initial hole so that grout stays in contact with the bottom of the baseplate at all times. Commence grouting at the next hole with an additional headbox. Continue process, alternating headboxes until grouting is complete.
- C. When pouring into the headbox, grout shall be introduced in a manner to avoid air entrapment. Care must be taken during grouting to keep the headbox at least half full of material to ensure even grout flow. If necessary to assist the flow, a plunger may be used. This procedure shall continue until the grout rises above the bottom edge of the baseplate on the opposite side.
- D. Throughout the pour, forms shall be constantly checked for leaks. All leaks shall be sealed immediately.

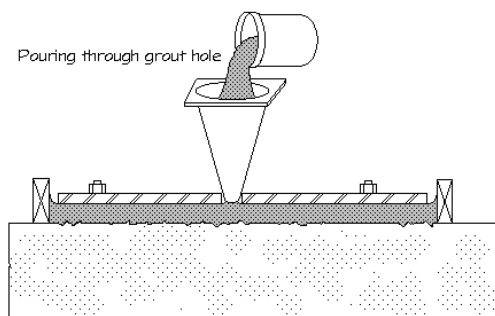
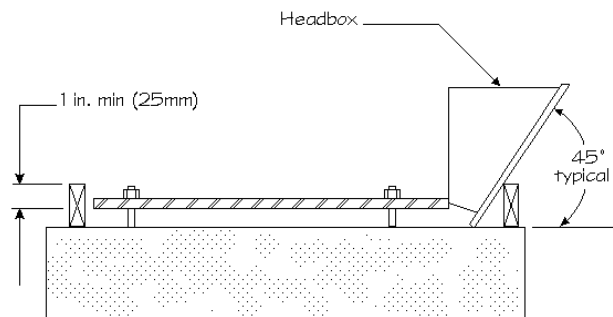

PART D – APPLICATION - CEMENTITIOUS GROUTING

4.01 PLACEMENT PROCEDURES PUMPING

- A. The type and size of pump and discharge line used are dependent on the parameters of each installation. Contact the pump and grout manufacturers for recommendations. The proposed pumping equipment and procedures shall be submitted for approval. Pump Five Star Fluid Grout 100 at less than fluid consistency.
- B. Pumping raises the grout temperature and shortens the working time while reducing its consistency. Keep mix temperature as cool as necessary, except in cold weather.
- C. The grout shall be mixed to a consistency that will not segregate while pumping.
- D. The grout shall be passed through a #4 screen prior to placement into the pump hopper.
- E. Before pumping, determine the working time under jobsite conditions. Pumpability shall be determined by field testing.
- F. The pump shall be positioned to minimize the pumping distance. Keep the discharge line as close to horizontal as possible. All hose connections must be watertight.
- G. Immediately prior to pumping, the pump and lines shall be primed with a priming slurry leaving hopper empty to prevent overwatering.
- H. Once the pumping has begun, it is important not to use any of the priming slurry from the discharge lines. Grout shall not be used until a uniform consistency is obtained at the discharge nozzle.
- I. Provide an adequate volume of mixed grout to keep the pump hopper at least half full. The grout shall be placed into pump hopper in a manner to prevent air entrapment.
- J. The discharge nozzle shall be withdrawn only while pumping, keeping it submerged within the grout at all times.
- K. When a pump is needed to transport grout and the nozzle cannot be inserted into the cavity being grouted, a headbox is required. The headbox will allow the pour to be continuous, avoiding air pockets under the plate. The grout shall be discharged from the nozzle into the headbox in a manner to avoid air entrapment. The headbox shall be kept at least half full at all times.
- L. All grouting shall take place from one side of the plate to the other. Maintain contact with the bottom of the plate at all times to maximize the effective bearing area (EBA).
- M. When pouring through grout holes, placement shall proceed continuously until the grout has risen in the next hole. Maintain head pressure at initial hole so that grout stays in contact with the bottom of the baseplate at all times. Commence grouting at the next hole with an additional headbox. Continue process, alternating head boxes until grouting is complete.

REFERENCE

ACI 304.2R-91
"Placing Concrete By Pumping Method"

PART E – FINISHING AND CURING - CEMENTITIOUS GROUTING

5.01 FINISHING

- A. Cut grout back from bottom of baseplate to the foundation at approximately a 45° angle or flush with baseplate as directed by the engineer. Formwork can be removed for cutback when grout offers stiff resistance, or when cut with a steel trowel, stands up without support. Finish exposed grout surfaces. Grout shall not be allowed to remain above the bottom edge of the baseplate.
- B. Proper grout shoulders

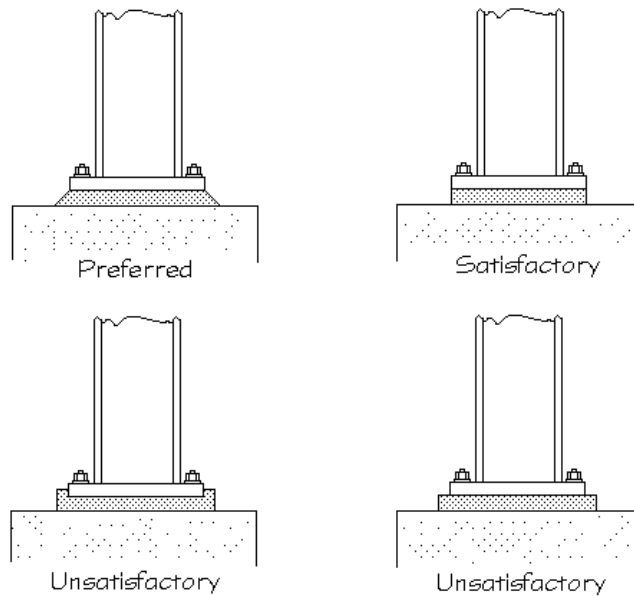

5.02 CURING

- A. Grout shall be wet cured for a minimum of three days, or coated with an approved curing compound after a minimum 24 hour wet cure. Grout shall be protected from excessive evaporation with wet rags prior to set.
- B. The grout shall be protected from wind, rain, freezing and vibration until a minimum compressive strength of 1000 psi (6.9 MPa) is achieved.

REFERENCES

ACI 351.1R-99
 "Grouting Between Foundations and Bases for Support of Equipment and Machinery"
 PCA 1990
 "Cementitious Grouts and Grouting"

PART F – EXTREME WEATHER CONDITIONS - CEMENTITIOUS GROUTING

6.01 COLD WEATHER GROUTING

[Low temperatures delay the set, increase working time and delay the strength development of cement-based products. The procedures below may compensate for these conditions.]

- A. Materials shall be conditioned as necessary so that the mixed grout is between 40°F and 80°F (4°C and 27°C). Due to the mass of palletized material, up to 72 hours of conditioning may be required. Store grout in an indoor or tarped and heated area when required.
- B. All surfaces in contact with grout must be preconditioned and maintained at a temperature between 40°F and 90°F (4°C and 32°C) for at least 24 hours.
- C. Heating shall be accomplished by indirect exposure. Heated enclosures must be windproof and weatherproof. Combustion heaters must be vented and shall not be permitted to heat and dry the concrete locally. *Caution: Exhaust gases may contaminate or cause carbonation within the enclosed environment.*
- D. Grout temperature shall be maintained above 40°F (4°C) until the grout reaches 1000 psi (6.9 MPa) or the required strength.
[Specify minimum required strength.]
- F. Gradually reduce temperature of grout to ambient temperature to avoid thermal shock.
[For low temperature conditions to 35°F (2°C), consider the use of Five Star® Instant Grout.]

REFERENCE

ACI 306R-88
"Cold Weather Concreting"

PART F – EXTREME WEATHER CONDITIONS - CEMENTITIOUS GROUTING

6.01 HOT WEATHER GROUTING

[High temperatures accelerate the set, decrease working time, and accelerate the strength gain of cement-based products. The procedures below may compensate for these conditions.]

- A. Materials should be pre-conditioned so that the grout mix temperature is between 50°F (10°C) and 95°F (35°C). Due to the mass of palletized material, up to 72 hours of pre-conditioning may be required. Store grout in a shaded area out of direct sunlight.
- B. All surfaces in contact with cement based grout shall be pre-conditioned and maintained below 95°F (35°C) for a minimum 24 hours. Pre soaking of surfaces, mixing equipment and wheelbarrows with cold or iced water will facilitate cooling of surfaces.
- C. Mix grout using cold or iced water. **Do not** put ice directly in with grout during mixing.
- D. Provide shading during grout placement and where feasible, place grout when temperatures are decreasing, at night or early morning. Provide protection from excessive wind to reduce rapid drying and evaporation of water from exposed grout surfaces.
- E. Begin wet cure immediately after grout takes initial set and continuously wet cure all exposed grout surfaces using wet rags, burlap or burlene. Place plastic sheeting over material used for wet cure to ensure continuous wet cure. Monitor condition of material used for wet cure to ensure drying does not occur.
- F. After a minimum 24 hour continuous wet cure, continue wet cure for an additional 48 hours or coat all exposed grout surfaces with an approved curing compound meeting the water retention requirements of ASTM C 309.

REFERENCE

ACI 305R-91
"Hot Weather Concreting"