



FIVE STAR PRODUCTS, INC.

FiveStarProducts.com
(800) 243-2206

DESIGN-A-SPEC™ GUIDELINES FIVE STAR® HYBRID GROUT

CONTENTS

▶	PART A - GENERAL CONDITIONS
▶	PART B - MATERIAL SPECIFICATIONS
▶	PART C - PREPARATION
▶	PART D - APPLICATION
▶	PART E - FINISHING AND CURING
▶	PART F - EXTREME WEATHER CONDITIONS

This document is provided for informational purposes only and as a general guideline for consideration by contractors and engineers. While every reasonable effort has been made to ensure that this information is accurate and authoritative, Five Star Products does not warrant the accuracy or completeness of this information, or for its appropriateness for any particular purpose. The user of this document remains solely responsible for the specification of all methods, materials and practices.

PART A - GENERAL CONDITIONS - CEMENTITIOUS GROUTING

1.01 SCOPE

The work covered by this document consists of furnishing all equipment, materials, labor and performing all operations required for the installation of nonshrink hybrid grouts as directed by the engineer or owner.

1.02 QUALITY ASSURANCE

- A. The manufacturer shall have been in the business of manufacturing similar products for over twenty years, maintain a strict quality assurance program, offer technical services and provide a representative at the jobsite for product training, prior to product installation, upon written request.
- B. The contractor shall submit to the engineer or owner, at least three job references where the contractor has successfully completed similar applications.

1.03 DELIVERY, STORAGE AND HANDLING

- A. All materials shall be delivered to the jobsite in their original, unopened packages, clearly labeled with the manufacturer's identification, printed instructions and batch code.
- B. Store and condition the specified product in accordance with the appropriate product data sheet.
- C. For handling instructions, refer to the Safety Data Sheet.

1.04 PROJECT/SITE CONDITIONS

Refer to PART C - PREPARATION, ENVIRONMENTAL CONDITIONS, or contact the manufacturer directly for any physical or environmental limitations required by the product.

1.05 MEASUREMENT AND PAYMENT

- A. Measurement of the grouting work shall be on a cubic foot (liter) basis of material in place.
- B. Payment for the grouting work shall be at the unit price bid on a cubic foot (liter) basis. This payment shall constitute full compensation for all labor, materials, tools, equipment and other items as necessary to complete the work as described in the contract documents. Progress payments will be made on the percentage of the work satisfactorily completed during each payment period in accordance with the provisions of the contract documents.

PART B - MATERIAL SPECIFICATION - CEMENTITIOUS GROUT**2.01 MATERIALS**

- A. Nonshrink hybrid grout shall be a highly flowable, pumpable consistency, cement-based grout requiring only the addition of potable water. The manufacturer shall be ISO 9001 certified and have at least 20 years experience in the manufacture of nonshrink cement-based grouts. The manufacturer shall offer technical services and provide a representative at the jobsite for product training prior to product installation upon five days advance notice.
- B. The grout shall not contain metallic aggregate, expansive cement, or gas generating additives such as aluminum powder. The grout shall contain an air release additive to generate positive expansion. The grout shall meet all the following typical performance criteria when cured at the following temperatures:

	35°F (2°C)	72°F (22°C)	100°F (38°C)*
Compressive Strength, ASTM C 942 (C109 Restrained): psi (MPa)			
8 Hour	-	4,000 (27.6)	5,000 (34.5)
1 Day	2,000 (13.8)	7,500 (51.7)	8,000 (55.2)
7 Days	8,000 (55.2)	13,000 (89.6)	13,000 (89.6)
28 Days	12,000 (82.7)	16,500 (113.8)	17,000 (117.2)
Bond Strength, ASTM C 882, 28 Days, concrete failure; psi (MPa)	4,000 (27.6)	4,000 (27.6)	4,000 (27.6)
Early Height Change, ASTM C 827	0.0 to 2.0%	0.0 to 2.0%	0.0 to 2.0%
Hardened Height Change, ASTM C 1090	0.0 to 0.2%	0.0 to 0.2%	0.0 to 0.2%
Effective Bearing Area, ASTM C 1339	≥ 95%	≥ 95%	≥ 95%
Flow, ASTM C 1339; seconds, 1" height	≤ 60	≤ 60	≤ 60
Consistency Flow Test, inches (mm) 2x4 in.(50x100 mm) cylinder	8-12 (200-300)	8-12 (200-300)	8-12(200-300)
Freeze/Thaw ASTM C 666, Durability Factor	≥ 95%	≥ 95%	≥ 95%

	35°F (2°C)	72°F (22°C)	100°F (38°C)*
Chloride Permeability, ASTM C 1202 28 days; rating (coulombs)	Very low (<1,000)	Very low (<1,000)	Very low (<1,000)
Modulus of Elasticity ASTM C 469 / 28 Days 3x6 in. (75x150mm) cylinder, Neat, psi (GPa)	-	4.5 x 10 ⁶ (31.0)	-

*100°F (38°C) properties are tested under controlled laboratory conditions. It is recommended that Hot Weather Grouting procedures (Part F Section 6.01) be followed during placement at elevated temperatures.

The data shown above reflect typical results based on laboratory testing under controlled conditions. Reasonable variations from the data shown above may result in the field. Test methods are modified where applicable.

- C. An acceptable product which meets these criteria is:

Five Star® Hybrid Grout

As manufactured by Five Star Products, Inc., Shelton, CT 06484 (203) 336-7900.

- D. Subject to meeting the performance criteria stated above, other hybrid grouts may be formally submitted to the engineer for approval up to three days prior to the bid date. All requests for approval shall contain certified test data verifying conformance with this specification. Three references of successfully completed projects of similar nature and scope of the work detailed in this specification shall be provided, as well as a minimum ten year history of use in the industry. The testing laboratory shall certify to any modifications made to tests performed and provide details of modifications.

2.02 CLEARANCES

- A. Placement thicknesses should be $\frac{3}{4}$ to 6 inches (19 to 150 mm). For depths greater than six inches (150 mm) refer to Aggregate Extension Section 2.03

2.03 AGGREGATE EXTENSION

- A. For pours greater than six inches (150 mm) in depth, the grout may be extended by the addition of clean, damp coarse aggregate according to the following guidelines:

<u>Depth of Pour</u> Inches (mm)	<u>Typical Extension</u> (Percentage by wt.)
6 + to 9 (150 – 225)	35%
9 + to 12 (225 – 350)	50%
12 + to 18 (225 – 450)	60%
18 + (450 +)	Contact Five Star Products

Coarse aggregate shall be clean and washed and conform to the requirements of ASTM C 33.

PART C – PREPARATION - CEMENTITIOUS GROUTING

3.01 CONCRETE SURFACES

- A. Completely remove all loose, delaminated and weak concrete, oil, grease, laitance and other contaminants. Prepare concrete using acceptable mechanical means and concrete cleaners and degreasers as necessary to obtain clean, sound and rough concrete surfaces exposing coarse aggregate. A Concrete Surface Profile (CSP) of 8-10 in accordance with ICRI Technical Guideline 310.2R* is recommended. Blow surfaces free of dust and debris using oil-free compressed air.
- B. Prior to placement, soak concrete surfaces thoroughly for a minimum of eight hours to an optimum 24 hours with potable water. Concrete shall be clean, saturated and free of standing water at time of placement.

3.02 METAL SURFACES

- A. Where bond to metal surfaces is not required, coat with a bond breaker such as paste wax or duct tape.
- B. Where bond to metal surfaces is required, the surface shall be clean, free of oil, grease, rust and other contaminants. Sandblasting to a SSPC-SP6** commercial finish will optimize bond development of grout to steel.
- C. Provide 1/4 to 1/2 inch (6 to 12 mm) air relief holes where baseplate configuration and high spots will entrap air.
- D. When grouting skid mounted equipment or frames, provide a four to six inch diameter (100 to 150 mm) grout filling hole in the center of each bulkhead section.

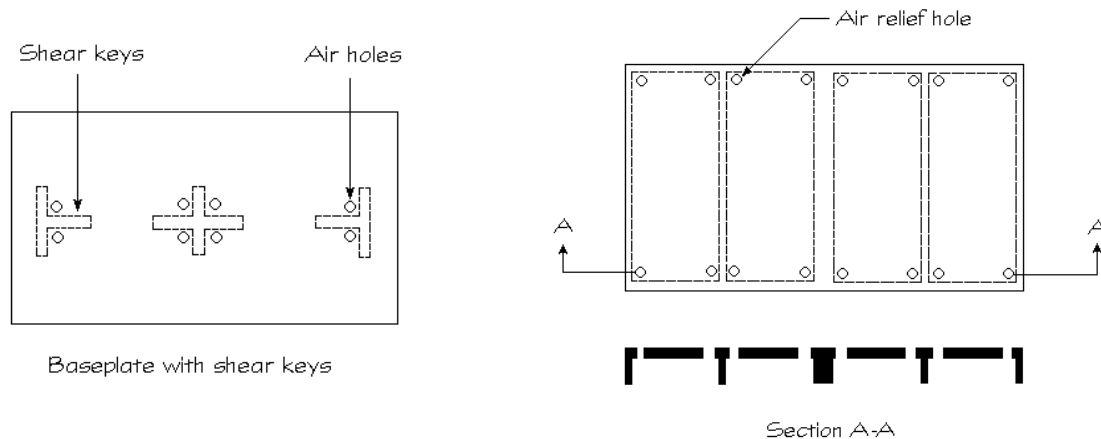

*ICRI Technical Guideline 310.2R Selecting and Specifying Concrete Surface Preparation

**SSPC-SP6

Commercial blast cleaned surface is defined as one in which all oil, grease, dirt, mill scale, rust and old paint have been completely removed from the blast cleaned surface, except that slight streaks, or discolorations caused by rust stain, mill scale oxides, or slight tightly adherent residues of paint or coating may remain. If the surface is pitted, slight residues of rust or paint may remain in the bottom of the pits. The slight discolorations mentioned above are limited to one-third of every square inch.

3.03 FORMWORK

- A. Formwork shall be constructed of rigid nonabsorbent materials, securely anchored, watertight and strong enough to resist forces developed during grout placement.
- B. Formwork shall be constructed so that the grout is placed across the shortest distance whenever possible. The clearance between formwork and baseplate shall be sufficient to allow for headbox. The clearance for remaining sides shall be one to three inches (25 to 75 mm) depending upon application requirements.
- C. Height of formwork shall extend a minimum of one inch (25 mm) above the bottom of the baseplate.
- D. All formwork shall be coated with a form release agent, wax or oil. Caution: Care should be taken not to contaminate grouting surfaces where bond is required.

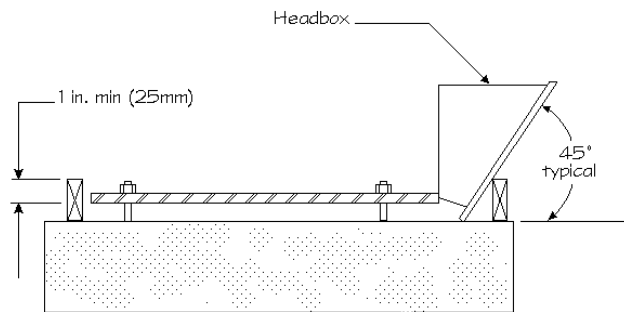

Formwork with Headbox

3.04 ENVIRONMENTAL CONDITIONS

- A. Condition and maintain all materials and surfaces that contact grout to between 35°F and 100°F (2°C and 38°C). Shade from direct sunlight as necessary.
[For detailed conditioning procedures for Cold Weather or Hot Weather Grouting, refer to PART F – EXTREME WEATHER CONDITIONS.]

3.05 LEVELING DEVICES

- A. All plates shall be set to final alignment before grouting using leveling devices such as shim packs, wedges, leveling nuts or jack screws. When shims and wedges are to remain in place, distance from edge of plate shall be a minimum of two inches (50 mm). Provide a minimum radius of two inches (50 mm) on all corners of shims and wedges. Sharp 90° corners on shim can cause grout cracking.
- B. Grease or isolate anchor bolts and leveling devices to prevent grout bond as necessary. Grout cracking at anchor bolt locations is often caused by grout bonded to anchor bolts.

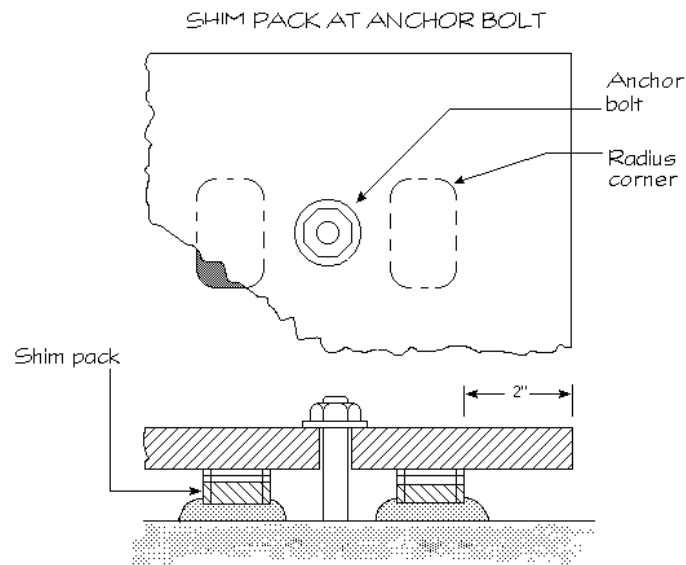

TYPICAL JACK SCREW DETAIL

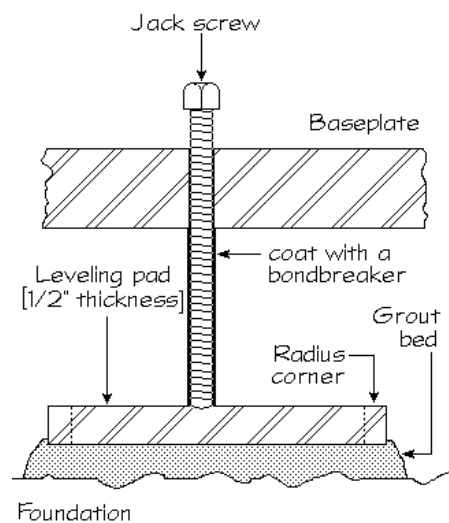

3.06 EQUIPMENT AND MATERIALS

- A. All necessary tools, equipment and materials shall be as close as possible to the area being grouted, such as mortar mixers, measuring containers, trowels and grout.
- B. Appropriate clothing and safety equipment shall be worn to avoid breathing dust and prevent eye and skin contact with both dry and mixed grout.
- C. Wheelbarrows, buckets, shovels and pumps shall be clean, dampened and readily available for transporting mixed grout.
- D. Provide headbox and plunger when pouring grout.
- E. An ample source of potable water shall be available for preconditioning, mixing, cleaning and curing.

3.07 MIXING

[Select one of the following types of mixers, as appropriate.]

Mortar Mixer (Stationary Barrel with Moving Paddles)

- A. Due to the nature of this material, an electric mortar mixer is not recommended (use gas, diesel or hydraulic mixers).
- B. Provide necessary number of mortar mixers in good operating condition for uninterrupted placement. Mix enough grout to utilize one-half the maximum capacity of the mortar mixer.
- B. Pre-wet mortar mixer, empty excess water.
- C. Start by adding 6.9 lbs (3.3 qts / 3.13 L) per bag of potable water to mixer. Add grout slowly while mixing and mix for approximately two minutes.
- D. Add additional water as needed up to a max of 0.60 lbs (0.29 qts / 0.27 L) per bag for a max total of 7.5 lbs (3.6 qts / 3.4 L) per bag and continue to mix for two to three minutes to achieve maximum flow.
- E. Do not mix more material than can be placed within the working time of the grout (30 minutes at 70°F/21°C). Do not retemper the mix by adding additional water.
- F. Transport mixed material by wheelbarrow, buckets, or pumping.
- G. For pours requiring aggregate extension, add clean, damp coarse aggregate meeting the requirements of ASTM C 33 after final water adjustment.

Drill and Paddle (Single Bag Mix Only)

- A. Use a heavy-duty power drill, shear mixing paddle and 7-gallon pail.
- B. Start by adding 6.9 lbs of water (3.3 qts / 3.13 L) to the pail. Add grout SLOWLY being careful not to overwhelm the drill.
- C. Mix for two minutes until all material is fully wet and incorporated.
- D. Add additional water as needed up to a max of 0.60 lbs (0.29 qts / 0.27 L) per bag for a max total of 7.5 lbs (3.6 qts / 3.4 L) per bag and continue to mix for two to three minutes to achieve maximum flow.

REFERENCES

ACI 351.1R-99

“Grouting Between Foundations and Bases for Support of Equipment and Machinery”

PCA 1990

“Cementitious Grouts and Grouting”

PART D – APPLICATION - CEMENTITIOUS GROUTING

4.01 PLACEMENT PROCEDURES

POURING

- A. A headbox or similar device is required for a continuous pour to avoid air pockets under baseplate. All grouting shall take place from one side to the other, maintaining contact with the bottom of the plate at all times, maximizing effective bearing area (EBA).
- B. When pouring through grout holes, placement shall proceed continuously with a headbox until the grout has risen in the next hole. Maintain head pressure at initial hole so that grout stays in contact with the bottom of the baseplate at all times. Commence grouting at the next hole with an additional headbox. Continue process, alternating headboxes until grouting is complete.
- C. When pouring into the headbox, grout shall be introduced in a manner to avoid air entrapment. Care must be taken during grouting to keep the headbox at least half full of material to ensure even grout flow. If necessary to assist the flow, a plunger may be used. This procedure shall continue until the grout rises above the bottom edge of the baseplate on the opposite side.
- D. Throughout the pour, forms shall be constantly checked for leaks. All leaks shall be sealed immediately.

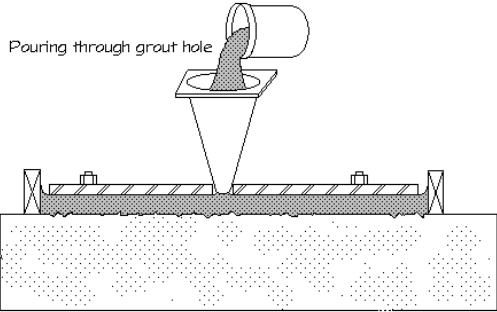
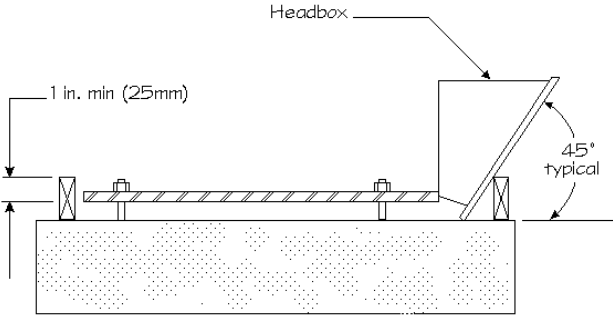

PART D – APPLICATION - CEMENTITIOUS GROUTING

4.01 PLACEMENT PROCEDURES PUMPING

- A. The type and size of pump and discharge line used are dependent on the parameters of each installation. Contact the pump and grout manufacturers for recommendations. The proposed pumping equipment and procedures shall be submitted for approval. Pump the grout at less than fluid consistency.
- B. Pumping raises the grout temperature and shortens the working time while reducing its consistency. Keep mix temperature as cool as necessary, except in cold weather.
- C. The grout shall be mixed to a consistency that will not segregate while pumping.
- D. The grout shall be passed through a #4 screen prior to placement into the pump hopper.
- E. Before pumping, determine the working time under jobsite conditions. Pumpability shall be determined by field testing.
- F. The pump shall be positioned to minimize the pumping distance. Keep the discharge line as close to horizontal as possible. All hose connections must be watertight.
- G. Immediately prior to pumping, the pump and lines shall be primed with a priming slurry leaving hopper empty to prevent overwatering.
- H. Once the pumping has begun, it is important not to use any of the priming slurry from the discharge lines. Grout shall not be used until a uniform consistency is obtained at the discharge nozzle.
- I. Provide an adequate volume of mixed grout to keep the pump hopper at least half full. The grout shall be placed into pump hopper in a manner to prevent air entrapment.
- J. The discharge nozzle shall be withdrawn only while pumping, keeping it submerged within the grout at all times.
- K. When a pump is needed to transport grout and the nozzle cannot be inserted into the cavity being grouted, a headbox is required. The headbox will allow the pour to be continuous, avoiding air pockets under the plate. The grout shall be discharged from the nozzle into the headbox in a manner to avoid air entrapment. The headbox shall be kept at least half full at all times.
- L. All grouting shall take place from one side of the plate to the other. Maintain contact with the bottom of the plate at all times to maximize the effective bearing area (EBA).
- M. When pouring through grout holes, placement shall proceed continuously until the grout has risen in the next hole. Maintain head pressure at initial hole so that grout stays in contact with the bottom of the baseplate at all times. Commence grouting at the next hole with an additional headbox. Continue process, alternating head boxes until grouting is complete.

REFERENCE

ACI 304.2R-91
"Placing Concrete By Pumping Method"

PART E – FINISHING AND CURING - CEMENTITIOUS GROUTING

5.01 FINISHING

- A. Grout should require almost no finishing and will basically self-level. If specified, cut grout back from bottom of baseplate to the foundation at approximately a 45° angle or flush with baseplate as directed by the engineer when grout has reached initial set. Formwork can be removed for cutback when grout offers stiff resistance, or when cut with a steel trowel, stands up without support. Grout shall not be allowed to remain above the bottom edge of the baseplate.
- B. Proper grout shoulders:

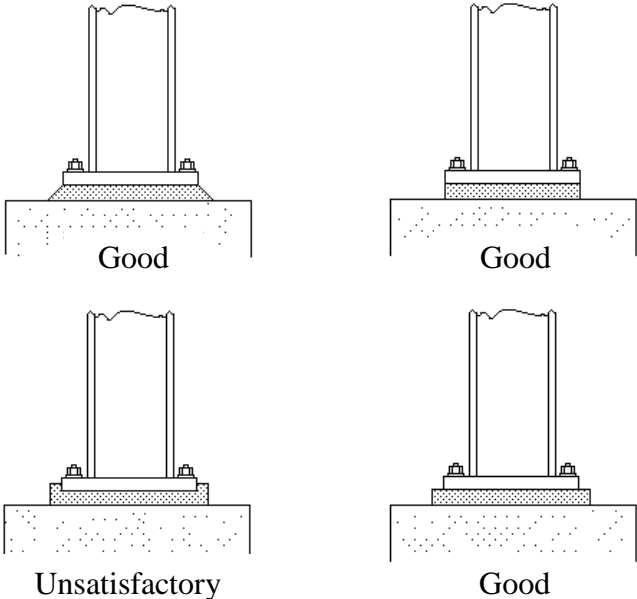

5.02 CURING

- A. Grout shall be wet cured for a minimum of three days, or coated with an approved curing compound after a minimum 24 hour wet cure. Grout shall be protected from excessive evaporation with wet rags prior to set.
- B. The grout shall be protected from wind, rain, freezing and vibration until a minimum compressive strength of 1,000 psi (6.9 MPa) is achieved.

REFERENCES

ACI 351.1R-99
"Grouting Foundations and Bases for Support of Equipment and Machinery"
PCA 1990
"Cementitious Grouts and Grouting"

PART F – EXTREME WEATHER CONDITIONS - CEMENTITIOUS GROUTING

6.01 COLD WEATHER GROUTING

[Low temperatures delay the set, increase working time and delay the strength development of cement-based products. The procedures below may compensate for these conditions.]

- A. Materials shall be conditioned as necessary so that the mixed grout is approximately 50°F-70°F (10°C-21°C). Due to the mass of palletized material, up to 72 hours of conditioning may be required. Store grout in an indoor or tarped and heated area when required.
- B. All surfaces in contact with grout must be preconditioned and maintained at a temperature between 35°F and 95°F (2°C and 35°C) for at least 24 hours.
- C. Heating shall be accomplished by indirect exposure. Heated enclosures must be windproof and weatherproof. Combustion heaters must be vented and shall not be permitted to heat and dry the concrete locally. *Caution: Exhaust gases may contaminate or cause carbonation within the enclosed environment.*
- D. Grout temperature shall be maintained at 35°F (2°C) or above until the grout reaches 1,000 psi (6.9 MPa) or the required strength.
- E. Gradually reduce temperature of grout to ambient temperature to avoid thermal shock.

REFERENCE

ACI 306R-88
"Cold Weather Concreting"

PART F – EXTREME WEATHER CONDITIONS - CEMENTITIOUS GROUTING

6.01 HOT WEATHER GROUTING

[High temperatures accelerate the set, decrease working time, and accelerate the strength gain of cement-based products. For placement temperatures over 95°F (35°C), the procedures below may compensate for these conditions.]

- A. Materials should be pre-conditioned so that the grout mix temperature is approximately 60°F-80°F (16°C-27°C). Due to the mass of palletized material, up to 72 hours of pre-conditioning may be required. Store grout in a shaded area out of direct sunlight.
- B. All surfaces in contact with cement based grout shall be pre-conditioned and maintained at or below 95°F (35°C) for a minimum 8 hours. Pre-soaking of surfaces, mixing equipment and wheelbarrows with cold or iced water will facilitate cooling of surfaces.
- C. Mix grout using cold or iced water. **Do not** put ice directly in with grout during mixing.
- D. Provide shading during grout placement and where feasible, place grout when temperatures are decreasing, at night or early morning. Provide protection from excessive wind to reduce rapid drying and evaporation of water from exposed grout surfaces.
- E. Begin wet cure immediately after grout takes initial set and continuously wet cure all exposed grout surfaces using wet rags, burlap or burlene. Place plastic sheeting over material used for wet cure to ensure continuous wet cure. Monitor condition of material used for wet cure to ensure drying does not occur.
- F. After a minimum 24 hour continuous wet cure, continue wet cure for an additional 48 hours or coat all exposed grout surfaces with an approved curing compound meeting the water retention requirements of ASTM C 309.

REFERENCE

ACI 305R-91
"Hot Weather Concreting"