



# FIVE STAR PRODUCTS, INC.

FiveStarProducts.com

(800) 243-2206

## DESIGN-A-SPEC™ GUIDELINES

# FIVE STAR® PILE JACKET GROUT HP

## CONTENTS

▶	<b>PART A - GENERAL CONDITIONS</b>
▶	<b>PART B - MATERIAL SPECIFICATIONS</b>
▶	<b>PART C - PREPARATION</b>
▶	<b>PART D - APPLICATION</b>
▶	<b>PART E - FINISHING AND CURING</b>

This document is provided for informational purposes only and as a general guideline for consideration by contractors and engineers. While every reasonable effort has been made to ensure that this information is accurate and authoritative, Five Star Products, Inc. does not warrant the accuracy or completeness of this information, or for its appropriateness for any particular purpose. The user of this document remains solely responsible for the specification of all methods, materials and practices.

## **PART A - GENERAL CONDITIONS**

### **1.01 SCOPE**

The work covered by this document consists of furnishing all materials and performing all operations required for pile repair / encapsulation using fiberglass pile jackets and moisture insensitive epoxy grout.

If it is determined that structural repairs to the pile are needed they must be performed in conjunction with the repairs described in this document. These repairs can include, but are not limited to, chipping out loose concrete, exposing rebar, cleaning rebar, replacing or adding rebar and filling the repaired area with grout.

### **1.02 QUALITY ASSURANCE**

The manufacturer shall be ISO 9001 certified and have a 15 year history of use in the manufacture of epoxy grout systems. The manufacturer shall provide on site technical service at no cost to the engineer or contractor when sufficient advance notice is provided.

### **1.03 DELIVERY, STORAGE AND HANDLING**

- A. All materials shall be delivered to the jobsite in their original, unopened packages, clearly labeled with the product identification, printed instructions and batch code.
- B. Store and condition the fiberglass jackets and pile jacket grout at 60°F to 80°F (16°C to 27°C) for at least 24 hours prior to use. Refer to the product data sheet for more information.
- C. For handling instructions, refer to the Safety Data Sheet.

### **1.04 PROJECT / SITE CONDITIONS**

- A. Refer to Part C – PREPARATION, ENVIRONMENTAL CONDITIONS, or contact the manufacturer directly for any physical or environmental limitations required by the product.

### **1.05 MEASUREMENT AND PAYMENT**

- A. Measurement for pile repair / encapsulation shall be on a linear foot / cubic foot basis of material in place.
- B. Payment for pile repair / encapsulation shall be at the unit price bid on a linear foot/cubic foot basis. This payment shall constitute full compensation for all labor, materials, tools, equipment and other items as necessary to complete the work bid. Progress payments may be made on the percentage of work satisfactorily completed during each payment period in accordance with the contract provisions.

## PART B - MATERIAL SPECIFICATIONS

### 2.01 MATERIALS (EPOXY GROUT)

A. The pile encapsulation epoxy grout material shall be 100% solids, premeasured, pre-packaged epoxy system containing thermosetting epoxy resins, expansive additives and inert fillers. The material shall be nonshrink and suitable for placement underwater via pouring or pumping. The manufacturer shall have at least 10 years experience in the manufacture of epoxy grout systems and be ISO 9001 certified. The manufacturer shall offer technical services and provide a representative at the job site for product training prior to product installation.

B. The pile repair/encapsulation material shall meet the following performance criteria at 70°F (21°C):

	<b>Dry</b>	<b>Wet</b>
1. Compressive Strength ASTM C 579 B	psi (MPa)	psi (MPa)
1 Day	2,000 (13.8)	1,200 (8.27)
7 Days	10,000 (68.9)	5,000 (34.5)
28 Days	11,500 (79.3)	8,800 (60.7)
2. Tensile Strength, ASTM C 307 (7 days)	2,300 (15.9)	1,500 (10.3)
3. Bond to Concrete, ASTM C 882 (7 days)	3,500 (24.1)	1,500 (10.3)
4. Linear Shrinkage ASTM C 531	0.01%	0.01%
5. Water Absorption ASTM C 413	0.0%	0.0%
6. Working Time	90 minutes	90 minutes

C. An acceptable product that meets this criteria is:

#### **Five Star® Pile Jacket Grout HP**

As manufactured by Five Star Products, Inc. Shelton, CT 06484 (203) 336-7900.

## 2.02 AGGREGATE REDUCTION

Do not reduce aggregate loading beyond manufacturer's recommendations.

## 2.03 CLEARANCES

- A. The grout shall be placed from ½ to 6 inches (12 mm to 150 mm) around piles when used with a jacket retainer system.
- B. The maximum annular area of grout around piles shall be 6 inches.

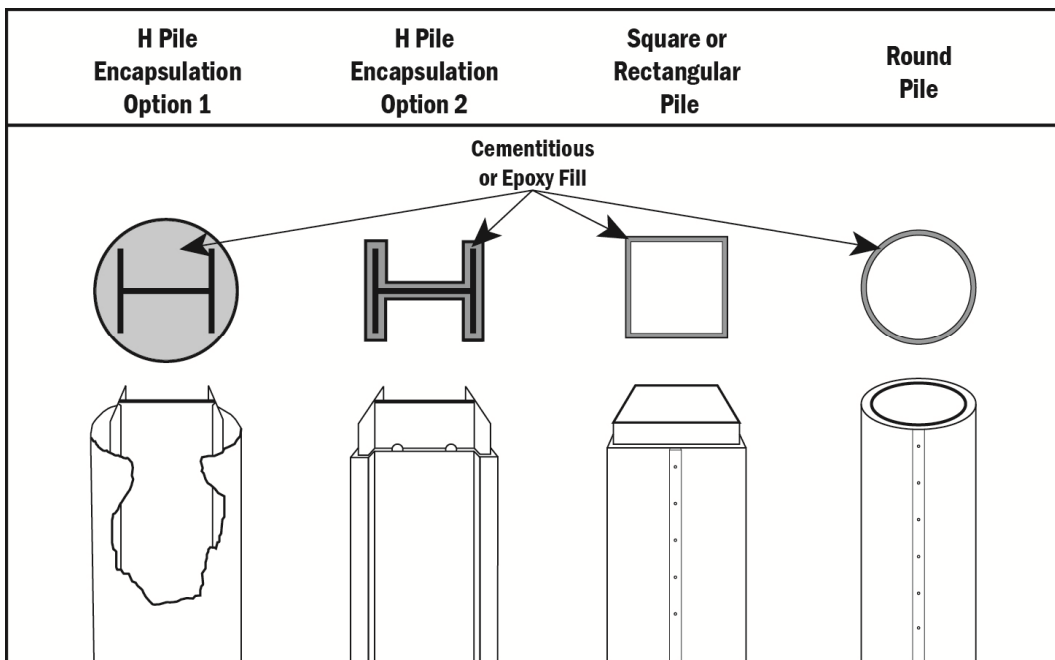

**Diagram A: Examples of pile jackets**

## PART C – PREPARATION

### 3.01 CONCRETE SURFACES

- A. Completely remove all loose, delaminated and weak concrete, oil, grease, laitance, marine growth and other contaminants. Prepare concrete using acceptable mechanical means and concrete cleaners and degreasers as necessary to obtain clean, sound and rough surfaces. Coarse aggregate shall be exposed.
- B. All cracks shall be brought to the attention of the engineer and a determination made of whether the cracks are subject to movement. The cracks shall be repaired as directed prior to installation of fiberglass jacket and epoxy grout.
- C. For more detailed information, refer to the following publication: "Guide for Surface Preparation for the Repair of Deteriorated Concrete Resulting from Reinforcing Steel Corrosion", Guideline No. 03730, prepared by the Technical Guidelines Committee of ICRI, March 1995.

### 3.02 REINFORCEMENT

- A. All reinforcing steel that has lost bond with the concrete or has more than one-half of its circumference exposed shall be undercut by at least 3/4 inch (18 mm) or two times the maximum aggregate size.

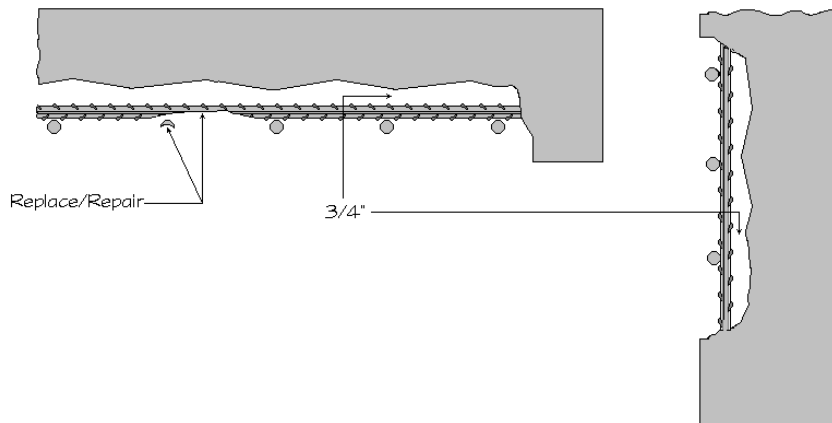

**Diagram D: Reinforcement Profile Example**

- B. If more than 20% of the diameter of a reinforcing bar has been deteriorated, the bar may require replacement or will need to be spliced as directed by the engineer.
- C. All reinforcement shall be rigidly secured and supported.
- D. All exposed reinforcing steel shall be free of all loose scale, rust, oxidation and other contaminants. Blast steel to an SSPC – SP6 commercial finish or better. Exposed reinforcing steel may be sealed or primed if a delay occurs between surface preparation and epoxy grout placement.

### 3.03 MIXING

#### **Mortar Mixer (Stationary Barrel Mixer with Moving Paddles)**

- A. Provide an adequate number of mortar mixers in good operating condition for uninterrupted placement. Do not exceed one-half the maximum capacity of the mortar mixer. A concrete mixer (spinning barrel mixer) is not recommended for mixing epoxy grout.
- B. Pour all Component B (hardener) into the pail containing Component A (resin). Mix thoroughly for 2 minutes by hand with paddle or slow speed mixer to avoid air entrapment. Pour mixed liquids into the mortar mixer. While mixing, slowly Component C (aggregate) and mix until aggregate is completely wet.
- C. Do not mix more material than can be placed within the working time of the grout.
- D. Pour the mixed grout into a suitable wheelbarrow or carrier to transport it to the work site.

## **PART D – APPLICATION**

### **4.01 Pumping**

- A. A peristaltic type pump is recommended for pumping epoxy grout. When using any other type of pump, consult epoxy grout manufacturer first to ensure the epoxy grout is pumpable with another type of pump.
- B. Prime pump and lines with a suitable primer that will not contaminate epoxy grout. Ensure material used for priming is discarded and not used for jacket filling.
- C. Attach the pump hose to the bottom port and commence pumping. For tremie pumping, insert hose into jacket to bottom and commence pumping. Keep pump hose submerged in epoxy grout and slowly raise pump hose as jacket fills with epoxy grout.
- D. When the grout in the jacket rises to the level of the next port stop the pump, remove the hose and close the port with a plug. Then attach the hose to the next higher port and continue pumping. Repeat this until the jacket is full of grout.
- E. When the jacket is full, the top of the jacket can be topped off with additional grout placed by hand or by a later placement of a suitable marine mastic such as Five Star® Splash Zone™.

- F. Do not mix more material than can be placed within the working time of the grout.
- G. All tools and equipment may be cleaned with high pressure water and a strong detergent prior to hardening. Sand may be used as an abrasive to aid clean up.

#### **4.02 Pouring**

- A. Use a headbox or ramp at top of jacket opening to facilitate pouring of epoxy grout into jacket.
- B. Mixing and pouring of epoxy grout should be a continuous process to minimize air entrapment. Headbox or ramp used for pouring may be moved or alternated from side to side to also help reduce air entrapment.
- C. Continue pouring epoxy grout until jacket is full. Grout level may be topped off using additional material placed by hand or by a later placement of a suitable marine mastic such as Five Star® Splash Zone™.
- D. Do not mix more material than can be placed in the working time of the epoxy grout.
- E. All tools and equipment may be cleaned with high pressure water and a strong detergent prior to hardening. Sand may be used as an abrasive to aid clean up.

### **PART E – FINISHING AND CURING**

#### **5.01 FINISHING**

- A. Prior to hardening, epoxy grout can be finished with a solvent wiped steel trowel. Maintaining a sufficient solvent coat is important as epoxy grout will adhere to a dry trowel.
- B. Epoxy grouts cannot be trimmed after set except by mechanical means. Final level in the forms should be brought to the finished elevation before curing.

#### **5.02 CURING**

- A. Protect the grout from temperatures below 40°F (4°C) for 24 hours or until required minimum compressive strength is achieved.

