



FIVE STAR PRODUCTS, INC.

www.fivestarprouducts.com

(800) 243-2206

DESIGN-A-SPEC™ GUIDELINES FIVE STAR SP EPOXY GROUT

CONTENTS

▶	PART A - GENERAL CONDITIONS
▶	PART B - MATERIAL SPECIFICATIONS
▶	PART C - PREPARATION
▶	PART D - APPLICATION
▶	PART E - FINISHING AND CURING
▶	PART F - EXTREME WEATHER CONDITIONS

This document is provided for informational purposes only and as a general guideline for consideration by contractors and engineers. While every reasonable effort has been made to ensure that this information is accurate and authoritative, Five Star Products does not warrant the accuracy or completeness of this information, or for its appropriateness for any particular purpose. The user of this document remains solely responsible for the specification of all methods, materials and practices.

PART A - GENERAL CONDITIONS - EPOXY GROUTING

1.01 SCOPE

The work covered by this document consists of furnishing all equipment, materials, labor and performing all operations required for the installation of precision nonshrink grouts as directed by the engineer or owner.

1.02 QUALITY ASSURANCE

- A. The manufacturer shall have been in the business of manufacturing similar products for over ten years, maintain a strict quality assurance program, offer technical services and provide a representative at the jobsite for product training, prior to product installation, upon written request.
- B. The contractor shall submit to the engineer or owner, at least three job references where the contractor has successfully completed similar applications.

1.03 DELIVERY, STORAGE AND HANDLING

- A. All materials shall be delivered to the jobsite in their original, unopened packages, clearly labeled with the manufacturer's identification, printed instructions and batch code.
- B. Store and condition the specified product in accordance with the appropriate product data sheet.
- C. For handling instructions, refer to the Material Safety Data Sheet.

1.04 PROJECT/SITE CONDITIONS

Refer to PART C - PREPARATION, ENVIRONMENTAL CONDITIONS, or contact the manufacturer directly for any physical or environmental limitations required by the product.

1.05 MEASUREMENT AND PAYMENT

- A. Measurement of the grouting work shall be on a cubic foot (liter) basis of material in place.
- B. Payment for the grouting work shall be at the unit price bid on a cubic foot (liter) basis. This payment shall constitute full compensation for all labor, materials, tools, equipment and other items as necessary to complete the work as described in the contract documents. Progress payments will be made on the percentage of the work satisfactorily completed during each payment period in accordance with the provisions of the contract documents.

PART B - MATERIAL SPECIFICATIONS - EPOXY GROUT

2.01 MATERIALS

- A. Nonshrink epoxy grout shall be a 100% solids, very high strength, high performance, pre-packaged system containing thermosetting epoxy resins, expansive additives and inert fillers. The manufacturer shall be ISO 9001 certified and have at least 10 years experience in the manufacture of nonshrink epoxy grouts. The manufacturer shall offer technical services and provide a representative at the jobsite for product training prior to product installation upon five days advance notice.
- B. The grout material shall meet all the following typical performance criteria when post cured at 70°F (21°C):

1. Compressive Strength, ASTM C 579 B*

UNIT TYPE	STANDARD GRADE Comp. Strength psi (MPa)	PUMP GRADE Comp. Strength psi (MPa)
1 Day	16,500 (113.8)	16,500 (113.8)
7 Day	17,500 (120.7)	17,500 (120.7)
28 Days	20,000 (138.0)	20,000 (138.0)

2. Height Change, ASTM C 827

70°F (21°C)	Positive Expansion	Positive Expansion
	95%	95%

3. Effective Bearing Area 95%

95%

4. Tensile Strength, ASTM C 307

70°F (21°C)	2,000 psi (13.8 MPa)	2,300 psi (15.9 MPa)

5. Creep, ASTM C 1181

1 Year, 400 psi (2.8 MPa), 140°F (60°C)	0.5 x 10 ⁻³ in/in	1.0 x 10 ⁻³ in/in

6. Flexural Strength,

ASTM C 580	5,000 psi (34.5 MPa)	5,500 psi (37.95 MPa)

7. Bond to Concrete,

ASTM C 882	Concrete Failure	Concrete Failure

8. Coefficient of Expansion,

ASTM C 531	16 x 10 ⁻⁶ in/in/°F (28.8 x 10 ⁻⁶ mm/mm/°C)	17 x 10 ⁻⁶ in/in/°F (30.6 x 10 ⁻⁶ mm/mm/°C)

*Rate of loading 0.25 inches per minute.

The data shown above reflect typical results based on laboratory testing under controlled conditions.

Reasonable variations from the data shown above may result in the field. Test methods are modified where applicable.

- C. An acceptable product which meets these criteria is:

Five Star® SP Epoxy Grout

As manufactured by Five Star Products, Inc., Shelton, CT 06484 (203) 336-7900.

- D. Subject to meeting the performance criteria stated above, other products may be formally submitted to the engineer for approval up to three days prior to the bid date. All requests for approval shall contain certified test data verifying conformance with the specification. Three references of successfully completed projects of similar nature and scope of the work detailed in this specification shall be provided as well as a minimum ten year history of use in the industry. The testing laboratory shall certify to any modifications made to the test performed and provide details of modifications.

2.02 AGGREGATE REDUCTION

- A. Aggregate content of the epoxy grout shall not be reduced.
B. Where aggregate sources other than those from grout manufacturer are allowed, grout manufacturer must specify type of aggregate allowed and amount per mix. Test data must be provided for aggregate sources other than grout manufacturer.

2.03 CLEARANCES

- A. The grout shall be placed from one to four inches (25 mm to 100 mm) in depth. For baseplate clearances less than one inch (25 mm) or greater than four inches (100 mm), contact the manufacturer.

PART C – PREPARATION - EPOXY GROUTING

3.01 CONCRETE SURFACES

- A. Concrete surfaces shall be a minimum 28 days old, dimensionally stable, free of oil, grease, laitance and other contaminants. Mechanically roughen surfaces to obtain clean, sound concrete by acceptable mechanical means, exposing coarse aggregate. Use tools such as pneumatic chipping guns for mechanical surface preparation. Do not use jack hammers to prepare concrete surfaces.
- B. Prior to placement, concrete surfaces shall be visibly dry and blown free of dust and debris using oil-free compressed air.

3.02 METAL SURFACES

- A. Where bond to metal surfaces is not required, coat with a bond breaker such as paste wax or duct tape.
- B. Where bond to metal or primed surfaces is required, the surface shall be clean, free of oil, grease, rust and other contaminants. Sandblasting to a SSPC-SP6* commercial finish will optimize bond development of epoxy to steel.
- C. To prevent oxidation steel surfaces should be coated with an acceptable epoxy primer when grout is not placed within 12 hours of sandblasting. Steel primer must be epoxy based and approved by the grout manufacturer.
- D. Equipment and baseplates should be grouted within the open time of the steel primer as recommended by the primer manufacturer. If open time is exceeded, primer surfaces should be sanded or abraded prior to grouting and wiped with a solvent coated rag.

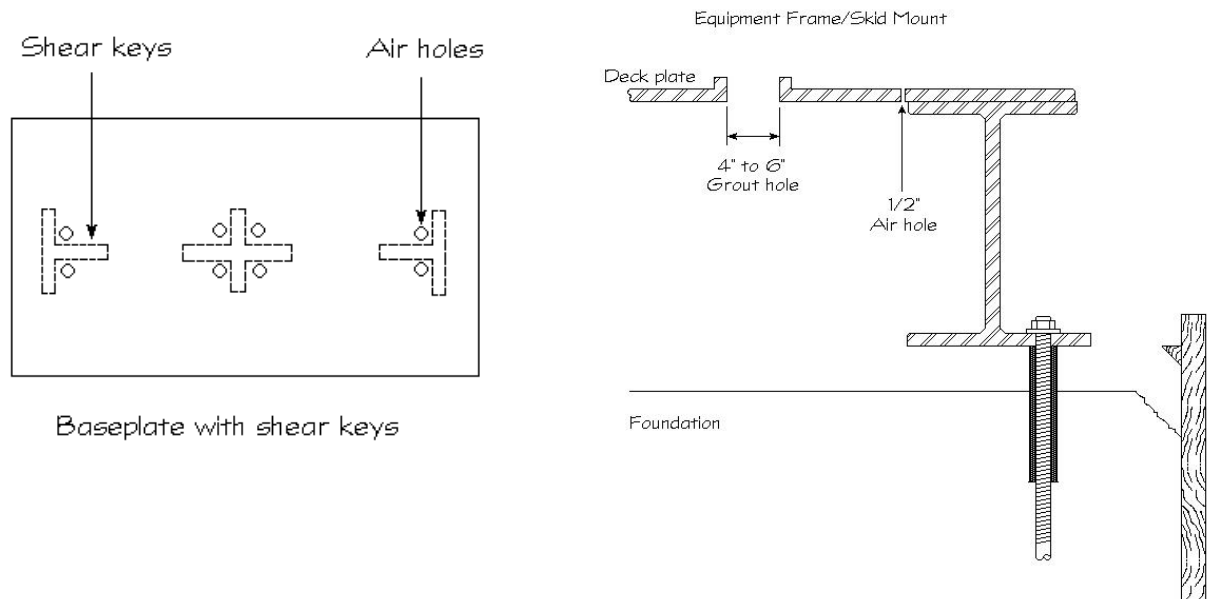

*SSPC-SP6

Commercial blast cleaned surface is defined as one in which all oil, grease, dirt, mill scale, rust and old paint have been completely removed from the blast cleaned surface, except that slight streaks, or discolorations caused by rust stain, mill scale oxides, or slight tightly adherent residues of paint or coating may remain. If the surface is pitted, slight residues of rust or paint may remain in the bottom of the pits. The slight discolorations mentioned above are limited to one-third of every square inch.

3.03 SKID MOUNTED EQUIPMENT

- A. Jack screws or similar device should be used to level baseplates. Jack screws should have a steel bearing plate and should not bear directly on concrete surfaces. Bearing plates should have rounded edges to reduce stress concentrations in grout.
- B. Jack screw bearing plates should be a minimum ½ inch thick. Jack screws must be coated with a suitable bond breaker to allow removal after grout has cured. Jack screws should remain in place for 72 hours prior to removal.
- C. When shims are used to level baseplates, they must have rounded corners to reduce stress concentrations and cracking in epoxy grout. Shims may be left in place or isolated for future removal.
- D. Anchor bolts and sleeves should be wrapped and sealed using Dux-Seal or similar material from grout bonding to anchor bolt and filling anchor bolt sleeve. Where sleeves are present, sleeves should be completely dry and free of water.
- E.

TYPICAL JACK SCREW DETAIL

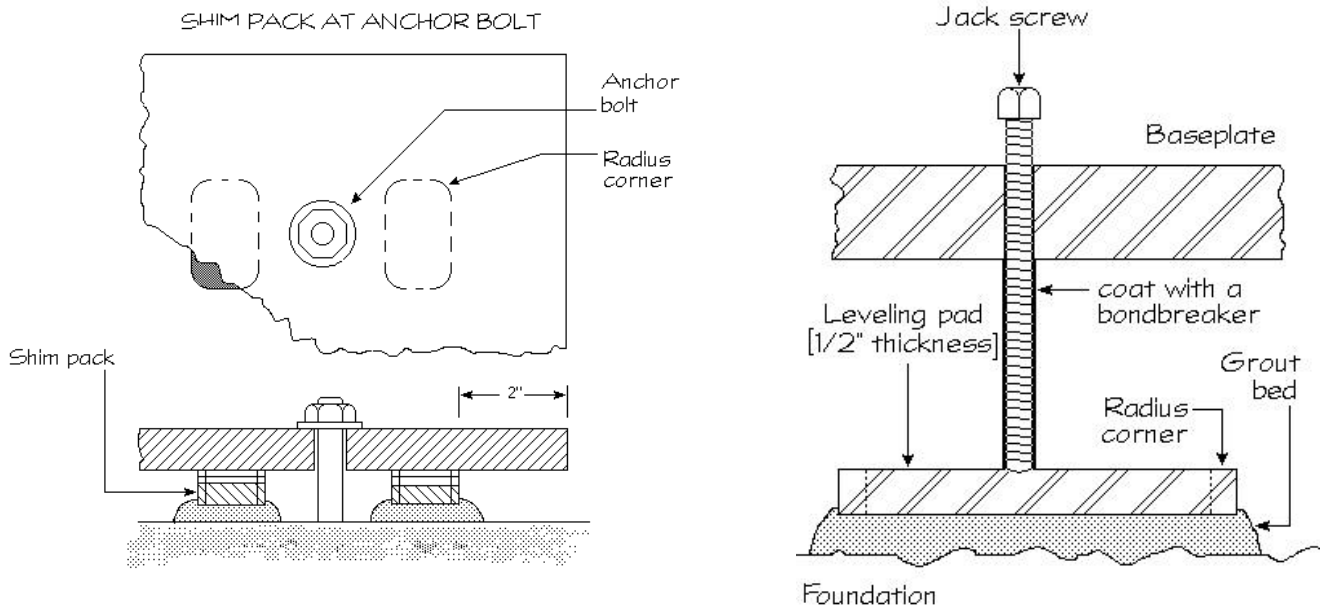

3.04 FORMWORK

- A. Formwork shall be constructed of rigid nonabsorbent materials, securely anchored, caulked liquid tight and strong enough to resist forces developed during grout placement. Chamfer edges shall be built into forms before grout placement.
- B. Formwork shall be constructed so that grout is placed across the shortest distance whenever possible. The clearance between formwork and baseplate shall be sufficient to allow for headbox. The clearance for remaining sides shall be one to three inches (25 to 75 mm).

Epoxy grout shoulders should not exceed 3 inches without additional mechanical anchoring.

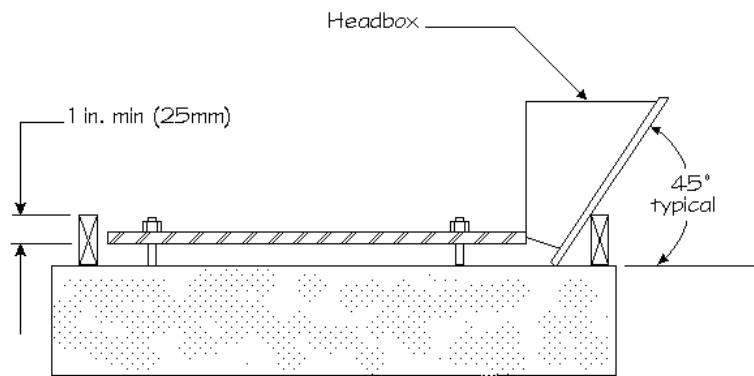

- C. Height of formwork shall extend a minimum of one inch (25 mm) above bottom edge of the baseplate. Grout forms shall have one inch (25 mm) chamfer strips at all vertical corners and top edges of grout shoulders.

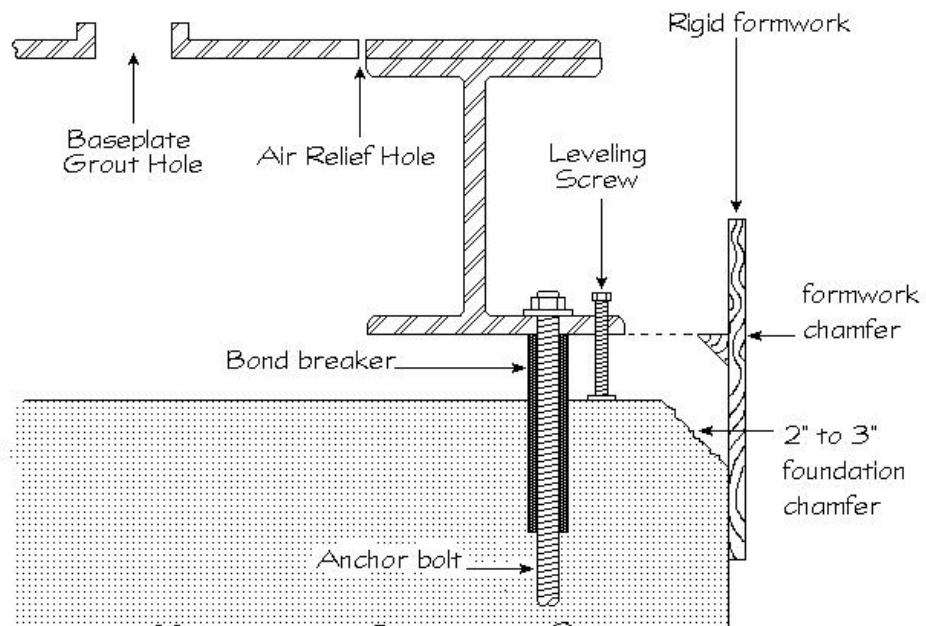

- D. All formwork shall be coated with a bond breaker such as two coats of paste wax or polyethylene. Form release oil is not acceptable. Caution: Care should be taken not to contaminate grouting surfaces where bond is required.

3.05 ISOLATION JOINTS

- A. Isolation joints are recommended for most epoxy grout pours. Joint material may be closed cell Styrofoam, redwood or butyl rubber waxed or coated to prevent bond. Joints should be spaced typically on 4 to 6 foot centers depending upon equipment footprint and layout. Calculate volume of epoxy grout to be placed and ensure pour volume between joints does not exceed manufacturer's recommendations.
- B. Joint material may be removed after grout cures and areas filled with a suitable joint filler.

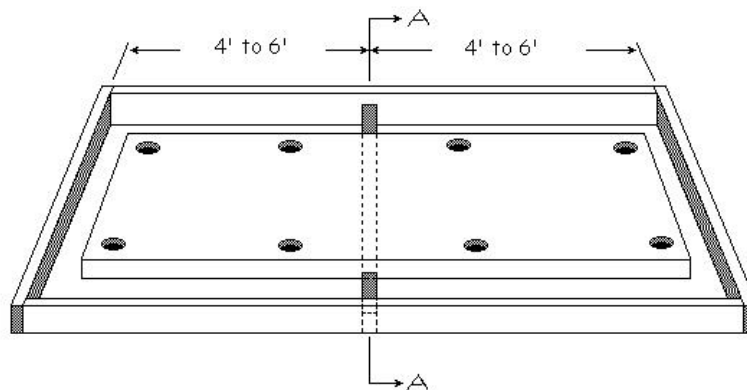

3.06 SHOULDERS

- A. Unconfined epoxy grout shoulders can result in tensile stresses, edge lifting and cracking in epoxy grout and concrete foundation. To minimize this, unconfined epoxy grout shoulders should be kept to 3 inches maximum wherever possible.
- B. Pinning of epoxy grout shoulders is recommended. Pins should be placed on approximately 8 to 10 inch centers and typically are #6 or #8 rebar grouted in place using Five Star RS Anchor Gel or similar adhesive. Pins should extend out of concrete foundation a maximum $2/3$ depth of the grout.
- C. Larger shoulders may be overlaid with Five Star Structural Concrete. Area between epoxy grout and Structural Concrete may be treated as a joint and filled accordingly.

3.07 ENVIRONMENTAL CONDITIONS

- A. Condition and maintain materials to between 70°F and 80°F (21°C and 27°C) and all surfaces that contact grout to between 60°F and 90°F (15°C and 32°C). Shade from direct sunlight as necessary.
[For detailed conditioning procedures for Cold Weather or Hot Weather Grouting, refer to PART F – EXTREME WEATHER CONDITIONS.]

3.08 CLEARANCES

- A. Epoxy grout shall be placed from 1 to 4 inches in depth. Volume of grout placed shall not exceed manufacturer's recommendations

3.09 EQUIPMENT AND MATERIALS

- A. All necessary tools, equipment and materials shall be as close as possible to the area being grouted, such as mixers, trowels and grout. Provide an adequate number of mixers, in good operating condition, for uninterrupted placement. Equipment shall be clean and dry.
- B. Appropriate clothing and safety equipment shall be worn to avoid breathing dust and prevent eye and skin contact with components and mixed grout.
- C. Wheelbarrows and buckets shall be clean and available for transporting mixed grout.
- D. Provide headbox and plunger when pouring grout.
- E. An appropriate material shall be available for clean up. Refer to data sheet of the grout specified.

3.10 MIXING

Mortar Mixer (Stationary Barrel with Moving Paddles)

- A. Always use at least one-half the capacity of mixer when mixing grout.
- B. Combine Component A (resin) and Component B (hardener) by pouring Component B (hardener) into pail containing Component A (resin). Mix thoroughly by hand with a paddle or by slow speed mixer until a uniform color is obtained (no streaks); avoid air entrapment. Immediately pour all mixed liquids into mortar mixer. While mixing at a slow speed (approximately 20RPM), slowly add Component C (aggregate) without delay and mix only until aggregate is completely wet.
- C. Do not mix more material than can be placed within the working time of the grout.

PART D – APPLICATION - EPOXY GROUTING

4.01 PLACEMENT PROCEDURES

POURING

- A. Grout must be placed without interruption. Should a delay occur beyond the working time of the material, all equipment used in mixing and placing the epoxy grout, shall be cleaned.
- B. A headbox or similar device is required for a continuous pour to avoid air pockets under the baseplate. All grouting shall be placed from one side to the other, maintaining contact with the bottom of the baseplate at all times, maximizing effective bearing area (EBA).
- C. When installing grout under long baseplates, start pouring from one end across the short dimension and work down the longer side as the material fills under the baseplate.
- D. When pouring through grout holes, placement shall proceed continuously with a headbox until the grout has risen in the next hole. Maintain head pressure at initial hole so that grout stays in contact with the bottom of the baseplate at all times. Commence grouting at the next hole with an additional headbox. Continue process, alternating headboxes until grouting is complete.
- E. When pouring, the headbox shall be kept at least half full and filled in a manner to avoid air entrapment. If necessary to assist the flow, a plunger may be used. This procedure shall continue until the grout rises above the bottom edge of the baseplate on the opposite side.
- F. Throughout the pour, forms shall be constantly checked for leaks. All leaks shall be sealed immediately.
- G. If two or more layers are necessary, rake or scarify the surface of the initial pour. The surface temperature of the initial pour shall have cooled to 90°F (32°C) maximum prior to placing additional layers. Additional layers shall be placed within 24 hours.

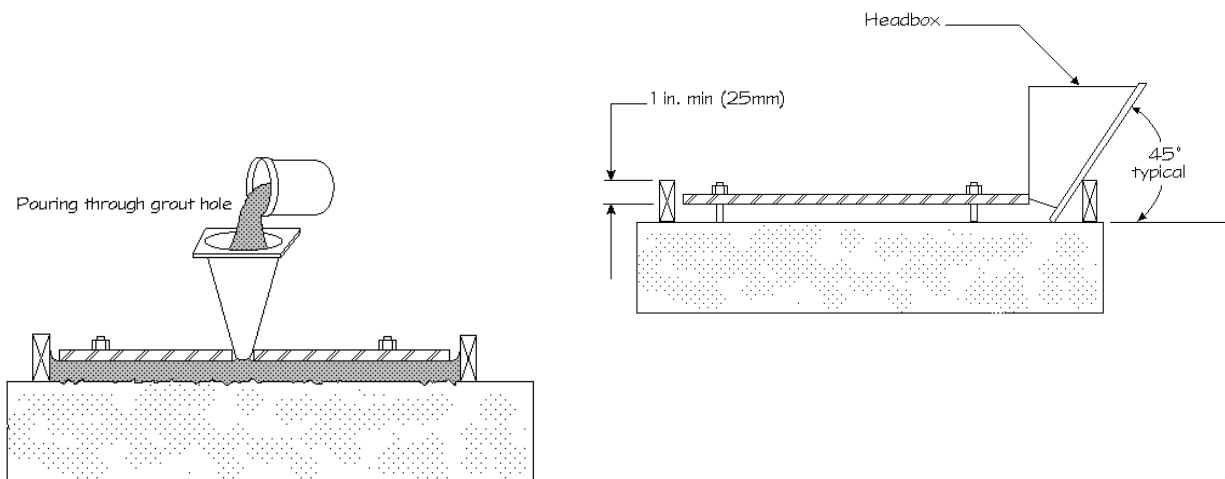

PART E – FINISHING AND CURING - EPOXY GROUTING

5.01 FINISHING

- A. Prior to hardening, epoxy grout can be finished with a solvent wiped steel trowel. Maintaining a sufficient solvent coat is important as epoxy grout will adhere to dry trowel.
- B. Joint materials may be removed after the grout has cured and filled with a flexible compound.
- C. Epoxy grouts cannot be trimmed after set except by mechanical means. Final level in the forms should be brought to the finished elevation before hardening.

5.02 CURING

- A. Protect grout from temperature extremes, rain and water after placement. Do not wet cure epoxy grout.
- B. The grout shall be protected from temperatures below 45°F (7°C) until required minimum compressive strength is achieved.
- C. In-service operation may begin immediately after minimum required grout strength and modulus have been achieved.

REFERENCES

ACI 351.1-R93
"Grouting for Support of Equipment and Machinery"

PIP/API RP-686
Machinery Installation Mounting Plate Grouting

API 610
Centrifugal Pumps for Petroleum, Heavy Duty Chemical and Gas Industry Services

PART F – EXTREME WEATHER CONDITIONS - EPOXY GROUTING

6.01 COLD WEATHER GROUTING

[Low temperatures decrease flow, delay set and strength development of epoxy products. The procedures below may compensate for these conditions.]

- A. All epoxy grout components (resin, hardener and aggregate) shall be pre-conditioned so that placed grout is between 70°F and 90°F (21°C and 32°C). Due to the mass of palletized material (aggregate component), up to 72 hours of pre-conditioning may be required. Store epoxy grout components in an enclosed, warm or heated area where necessary.
- B. Indirect heating of surfaces (steel, concrete) will also help compensate for cold temperatures. During mixing, the barrel of the mortar mixer may be heated using an appropriate heater to keep the grout mix temperature within an acceptable range.
- C. When necessary, heating shall be accomplished by indirect exposure. Heated enclosures must be windproof and weatherproof. Heaters shall not be permitted to unevenly heat concrete. *Caution: Exhaust gases of unvented heaters may contaminate or cause carbonation of concrete within the enclosed environment.*
- D. Grout temperature shall be maintained above 50°F (16°C) until grout reaches required strength.
[Specify minimum required strength.]
- E. Gradually allow grout temperature to cool to ambient to avoid thermal shock.

REFERENCES

ACI 351.1 - R93

"Grouting for Support of Equipment and Machinery"

PIP/API RP-686

Machinery Installation Mounting Plate Grouting

API 610

Centrifugal Pumps for Petroleum, Heavy Duty Chemical and Gas Industry Services

PART F – EXTREME WEATHER CONDITIONS - EPOXY GROUTING

6.01 HOT WEATHER GROUTING

[High temperatures accelerate set, decrease working time, and accelerate strength gain of epoxy products. The procedures below may compensate for these conditions.]

- A. All epoxy grout components (resin, hardener and aggregate) should be pre-conditioned so that the mixed material is between 60°F and 90°F (16°C and 32°C). Due to the mass of palletized material (aggregate) up to 72 hours of pre-conditioning may be required. Store all epoxy grout components in a cool, shaded area out of direct sunlight.
- B. All surfaces, equipment and tools in contact with epoxy grout should be shaded and kept at temperatures between 60°F and 90°F (16°C and 32°C). **Do not** use water to cool surfaces or equipment in contact with epoxy grout.
- C. Shade application area from direct sunlight and where feasible, place epoxy grout when temperatures are decreasing, at night or during early morning.
- D. Place epoxy grout immediately after mixing, do not allow epoxy grout to sit for extended periods of time in buckets or wheelbarrows.
- E. Maintain shading of application area for 24 hours after placement.

REFERENCES

ACI 351.1 - R93
"Grouting for Support of Equipment and Machinery"

PIP/API RP-686
Machinery Installation Mounting Plate Grouting

API 610
Centrifugal Pumps for Petroleum, Heavy Duty Chemical and Gas Industry Services