

# Grout Headbox & Plunger

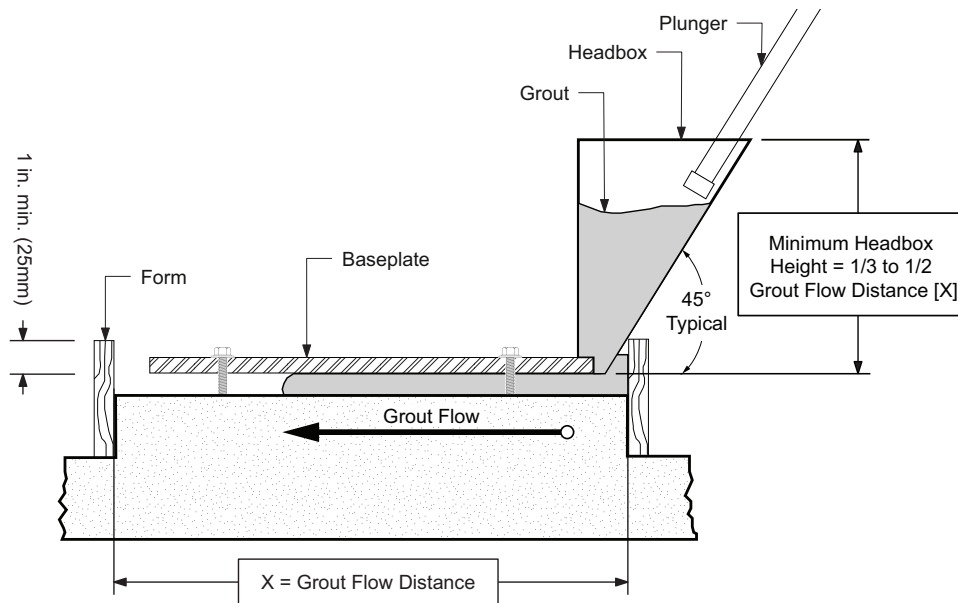

**A headbox is required for a continuous pour to avoid air pockets** under the baseplate and will improve grout flow significantly. When a headbox is used and hydraulic head pressure is the means of flowing grout into place, **the minimum height of the headbox should be from 1/3 to 1/2 the distance the grout must flow.**

**When pouring into a headbox,** grout shall be introduced in a manner to avoid air entrapment. Fill the headbox to the maximum height and allow the grout to flow down under the baseplate. Care must be taken during grouting to keep the headbox at least half full of material to ensure even grout flow.

**To prevent trapping of air under baseplate,** the level of grout in the headbox must never fall below the top of the baseplate. This procedure is repeated until the grout moves completely under the baseplate, pushing air out in front of it, and rising above the bottom of the baseplate on the far side.

**When the baseplate is long** and the headbox is less than the full length of the baseplate, begin grouting at one end of the long side. When the grout front reaches the far side, begin sliding the headbox down the length of the baseplate, keeping pace with the advancing grout front until the baseplate is completely grouted.

**To increase the rate of flow from a headbox,** manually apply pressure in addition to the hydraulic head by using a plunger. A plunger is a tool, usually fabricated on the job site, made from two pieces of wood nailed together to form a T. The stem is the plunger handle, and the cross-bar which is just slightly smaller than the width of the headbox, applies the pressure.

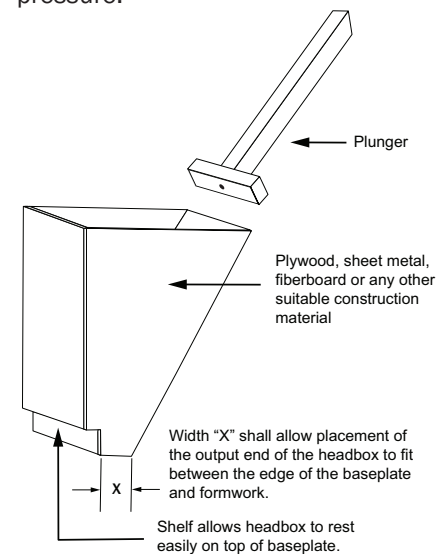

*For large, repetitive, or unique grouting applications, specially designed headboxes may be utilized.*



FIVE STAR TECHNICAL BULLETINS ARE PROVIDED FOR INFORMATIONAL PURPOSES ONLY AND SHOULD BE USED AS GENERAL GUIDELINES FOR CONSIDERATION BY CONTRACTORS AND ENGINEERS. WHILE EVERY REASONABLE EFFORT HAS BEEN MADE TO ENSURE THIS INFORMATION IS ACCURATE AND AUTHORITATIVE, FIVE STAR PRODUCTS DOES NOT WARRANT THE ACCURACY OR COMPLETENESS OF THIS INFORMATION, OR ITS APPROPRIATENESS FOR ANY PARTICULAR PURPOSE. THE USER OF THESE DOCUMENTS REMAINS SOLELY RESPONSIBLE FOR THE SPECIFICATION OF ALL METHODS, MATERIALS AND PRACTICES.