

FRY REGLET

SPRINGLOK FLASHING INSTALLATION INSTRUCTIONS

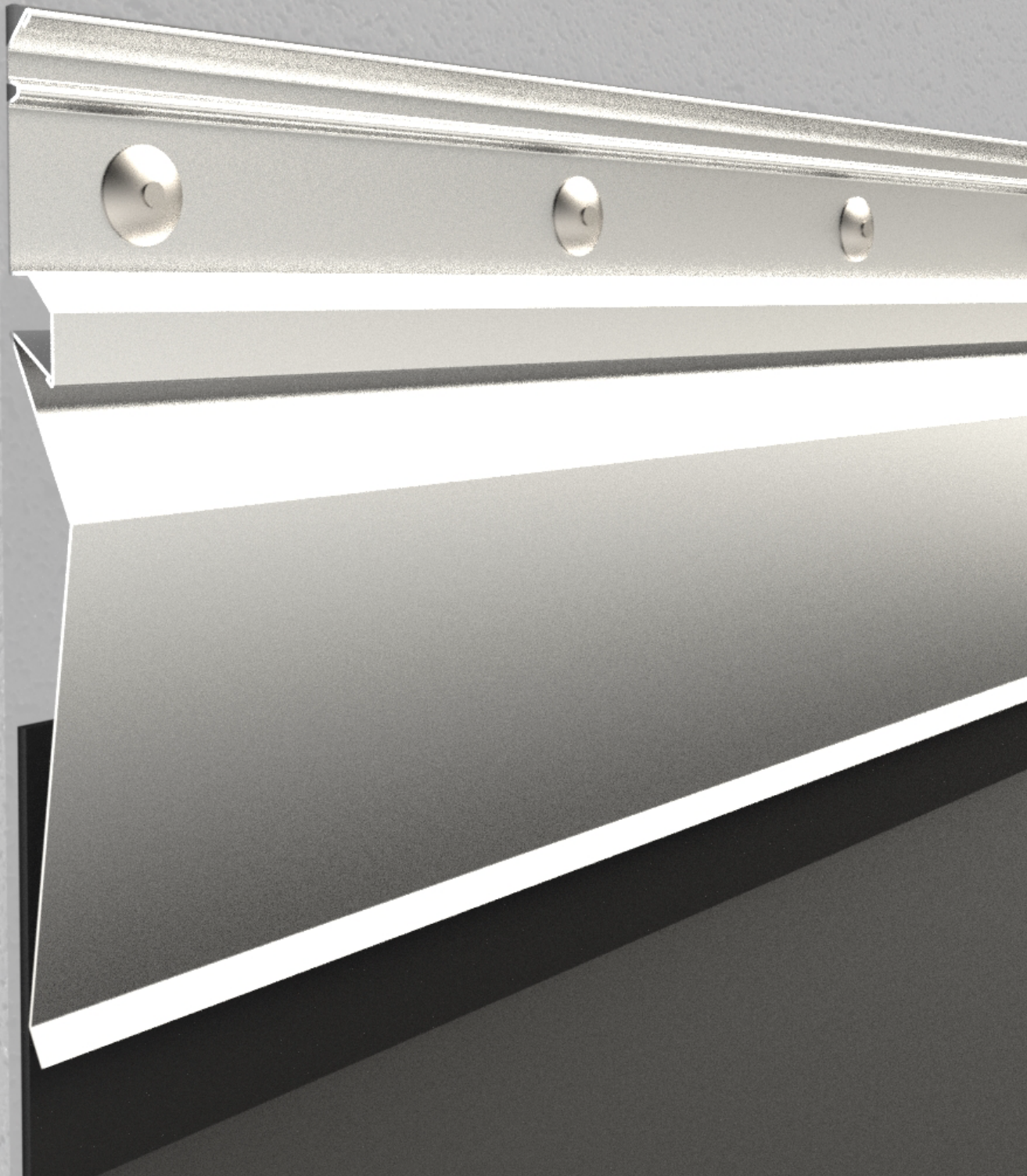

Fry Reglet Springlok® Flashing System

Type: CO-Concrete

7/09-2

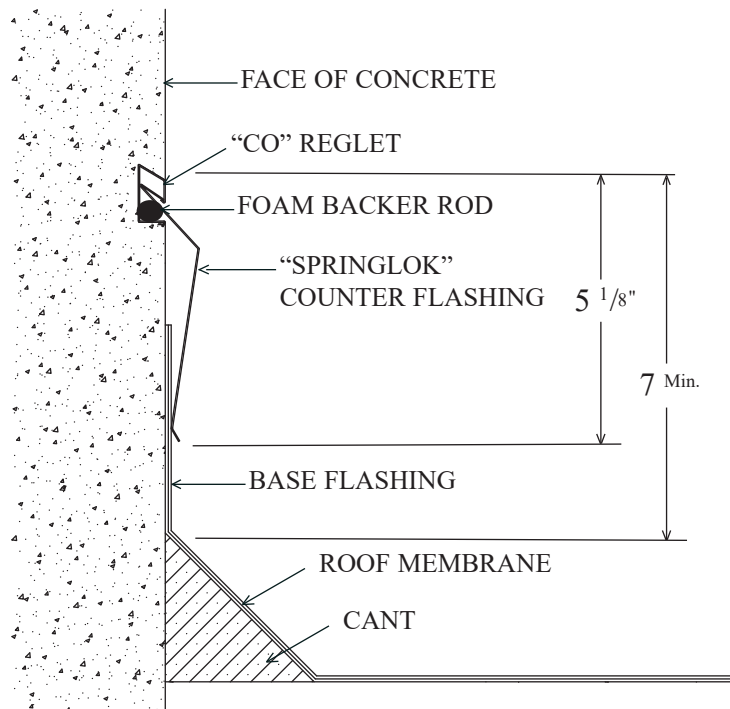

NOTE:

- 1). Lap adjacent lengths of counter flashing 3"

Description: Reglet & counter flashing system (2 piece, spring-action type). Available in copper, stainless steel, aluminum & galvanized steel.

Application: CAST-IN-PLACE CONCRETE. Not recommended for tilt-up construction (requires special provisions to ensure proper alignment between concrete panels).

Special Features: Factory-provided removable foam insert protects slot from obstruction during concrete pours.

Installation

General: 1). Install to heights on drawings; 2). Install reglets, then counter flashings; 3) See instructions titled *Factory-Fabricated Corners* and *Lap Joint & End Cap Erection*.

Reglets: 1). Install before pouring concrete; 2). Install factory fabricated inside & outside corners before installing straight lengths; 3). Fasten straight lengths to forms 16" o.c. max. using staples, screws or wire ties; 4). Make sure that reglets are right side up and that removable foam inserts are in place; 5). For proper alignment use factory provided clips at all joints; 6). Fasten reglets tight to forms to prevent leakage of wet concrete into slots; 7). After removal of forms, remove inserts before installing counter flashings.

Counter Flashings: 1). Verify that counter flashing is not bent or deformed, and that horizontal

Fry Reglet Corp / 12342 Hawkins Street, Santa Fe Springs, CA 90670 / 562.903.9500 / fax 562.944.4707
1377 Stonefield Court, Alpharetta, GA 30004 / 770.521.9660 / fax 770.521.9034

IMPORTANT NOTICE: Information contained herein is believed to be reliable, but no representation, guarantees or warranties of any kind are made as to its accuracy, suitability for particular applications or the results to be obtained therefrom. Before using, user shall determine products suitability for users intended use and shall assume all risk and liability in connection therewith. FRY REGLET DISCLAIMS ALL WARRANTIES, EXPRESS OR IMPLIED, INCLUDING BUT NOT LIMITED TO ANY IMPLIED WARRANTIES OF MERCHANTABILITY OR FITNESS FOR A PARTICULAR USE.

Fry Reglet Springlok® Flashing System

Type: CO-Concrete

7/09-3

Installation - cont.

dimension, measured from face of wall to apex of “V” shape of flashing, is 3/4” (dimension “A”); 2). Install factory mitered inside and outside corners before installing straight lengths; 3). remove foam inserts from reglets; 4). Maintaining constant horizontal pressure against face of wall, apply upward pressure with palm of hand until flashing snaps into reglet; 5). Lap 3” min.

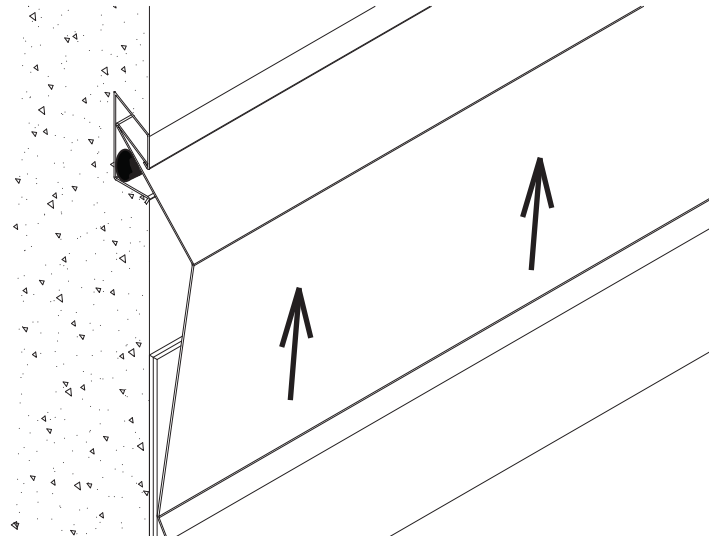

Counter Flashing Removal: 1). Insert putty knife at one end of counter flashing between counter flashing and reglet; 2). Apply slight pressure against counter flashing to force it away from face of reglet; 3). Press down on counter flashing to slide it out from under reglet.

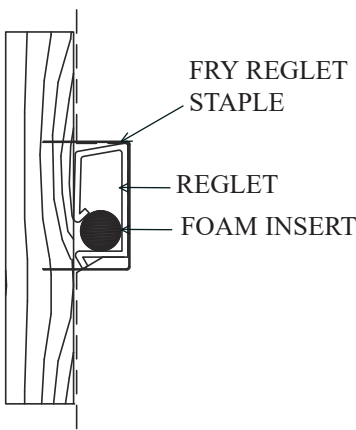

Staples

After removal of forms, cut exposed ends of staples flush with face of concrete.

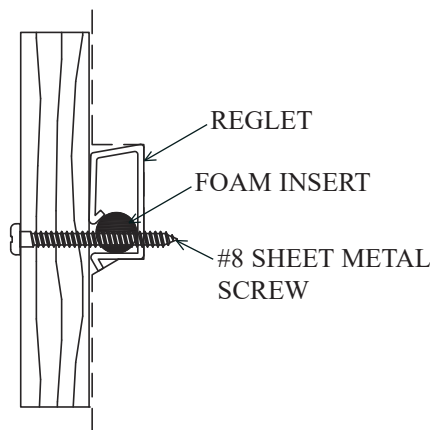

Screws

Carefully align and drill 1/4” screw holes in forms. Drive screws through holes to engage rear face of reglet. Tighten to secure reglet tight to forms. Remove screws prior to removing forms.

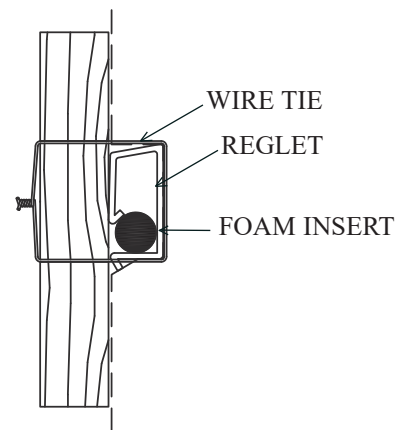

Wire Ties

Carefully align and drill holes for wire ties. Slip wire through holes and around rear face of reglet. Twist ends to secure reglet tight to forms. Cut ties prior to removing forms, cut exposed ends flush with face of concrete.

Fry Reglet Corp / 12342 Hawkins Street, Santa Fe Springs, CA 90670 / 562.903.9500 / fax 562.944.4707
1377 Stonefield Court, Alpharetta, GA 30004 / 770.521.9660 / fax 770.521.9034

IMPORTANT NOTICE: Information contained herein is believed to be reliable, but no representation, guarantees or warranties of any kind are made as to its accuracy, suitability for particular applications or the results to be obtained therefrom. Before using, user shall determine products suitability for users intended use and shall assume all risk and liability in connection therewith. FRY REGLET DISCLAIMS ALL WARRANTIES, EXPRESS OR IMPLIED, INCLUDING BUT NOT LIMITED TO ANY IMPLIED WARRANTIES OF MERCHANTABILITY OR FITNESS FOR A PARTICULAR USE.

Fry Reglet Springlok® Flashing System

Type: MA-Masonry

7/09-4

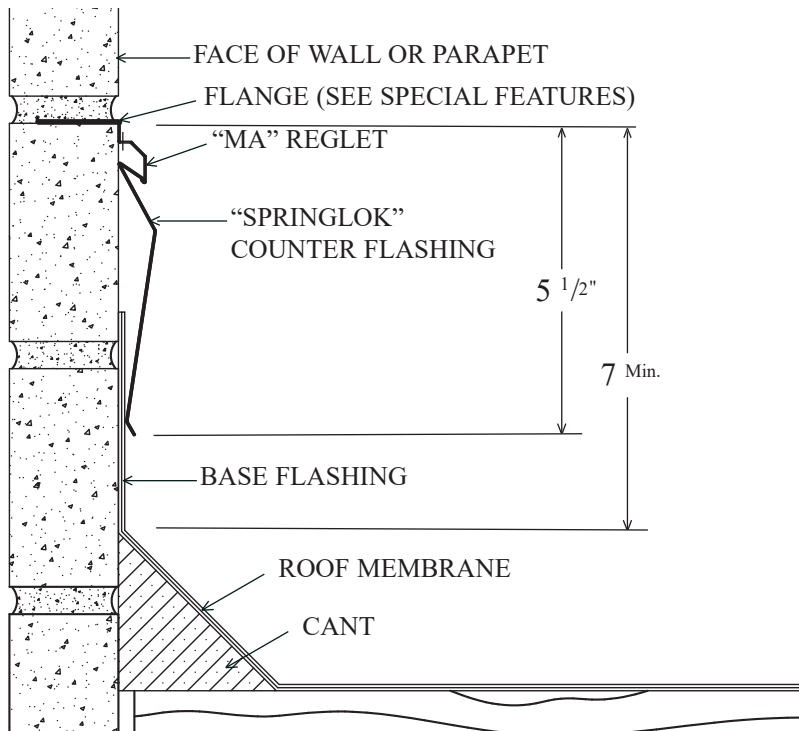

NOTE:

- 1). Lap adjacent lengths of reglet 1”.
- 2). Lap adjacent lengths of counter flashing 3”.

Description: Reglet & counter flashing system (2 piece, spring-action type). Reglet with 1-1/2” flange and counter flashing are available in copper, stainless steel, aluminum & galvanized steel. Reglet with 4” flange is available in copper, stainless steel, aluminum & galvanized steel.

Application: BRICK or CONCRETE MASONRY UNIT (CMU).

Special Features: Reglet is available with 1-1/2” horizontal flange (Reglet Type MA-1.5) for brick and 4” horizontal flange (Reglet Type MA-4) for CMU.

Installation

NOTE: FOR SAW-CUT INSTALLATIONS REFER TO PAGE 7/09-6

General: 1). Install to heights on drawings; 2). Install reglets, then counter flashings; 3) See instructions titled *Factory-Fabricated Corners* and *Lap Joint & End Cap Erection*.

Reglets: 1). Install factory fabricated inside & outside corners before installing straight lengths; 2). Make sure that reglets are right side up, tight to face of wall and fully supported at edge; 3). Embed in mortar between courses; 4). Lap ends 1” at stamped offset.

Counter Flashings: 1). Verify that counter flashing is not bent or deformed, and that horizontal

Fry Reglet Corp / 12342 Hawkins Street, Santa Fe Springs, CA 90670 / 562.903.9500 / fax 562.944.4707
1377 Stonefield Court, Alpharetta, GA 30004 / 770.521.9660 / fax 770.521.9034

IMPORTANT NOTICE: Information contained herein is believed to be reliable, but no representation, guarantees or warranties of any kind are made as to its accuracy, suitability for particular applications or the results to be obtained therefrom. Before using, user shall determine products suitability for users intended use and shall assume all risk and liability in connection therewith. FRY REGLET DISCLAIMS ALL WARRANTIES, EXPRESS OR IMPLIED, INCLUDING BUT NOT LIMITED TO ANY IMPLIED WARRANTIES OF MERCHANTABILITY OR FITNESS FOR A PARTICULAR USE.

Type: MA-Masonry

Installation - cont.

dimension, measured from face of wall to apex of “V” shape of flashing, is 3/4” (dimension “A”); 2). Install factory mitered inside and outside corners before installing straight lengths; 3). Maintaining constant horizontal pressure against face of wall, apply upward pressure with palm of hand until flashing snaps into reglet; 4). Lap 3” min.

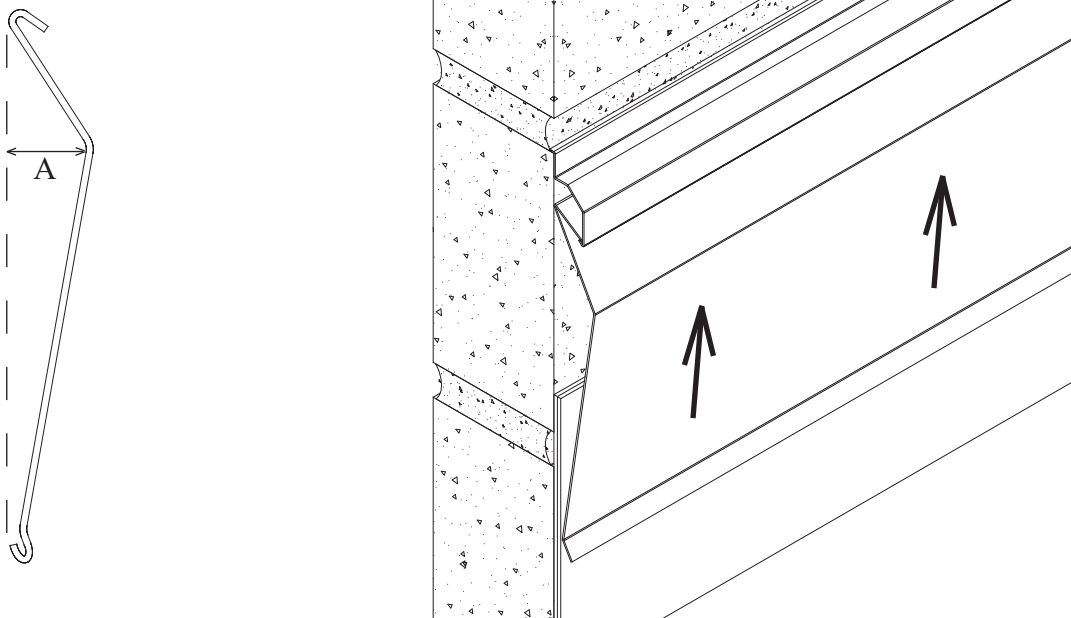

Counter Flashing Removal: 1). Insert putty knife at one end of counter flashing between counter flashing and reglet; 2). Apply slight pressure against counter flashing to force it away from face of reglet; 3). Press down on counter flashing to slide it out from under reglet.

Fry Reglet Springlok® Flashing System

Type: MA-Masonry Saw-Cut Installation

7/09-6

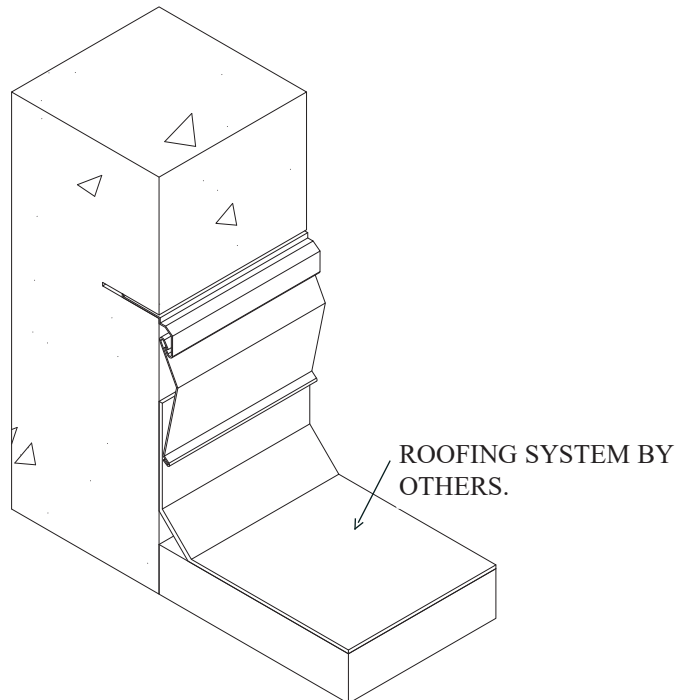
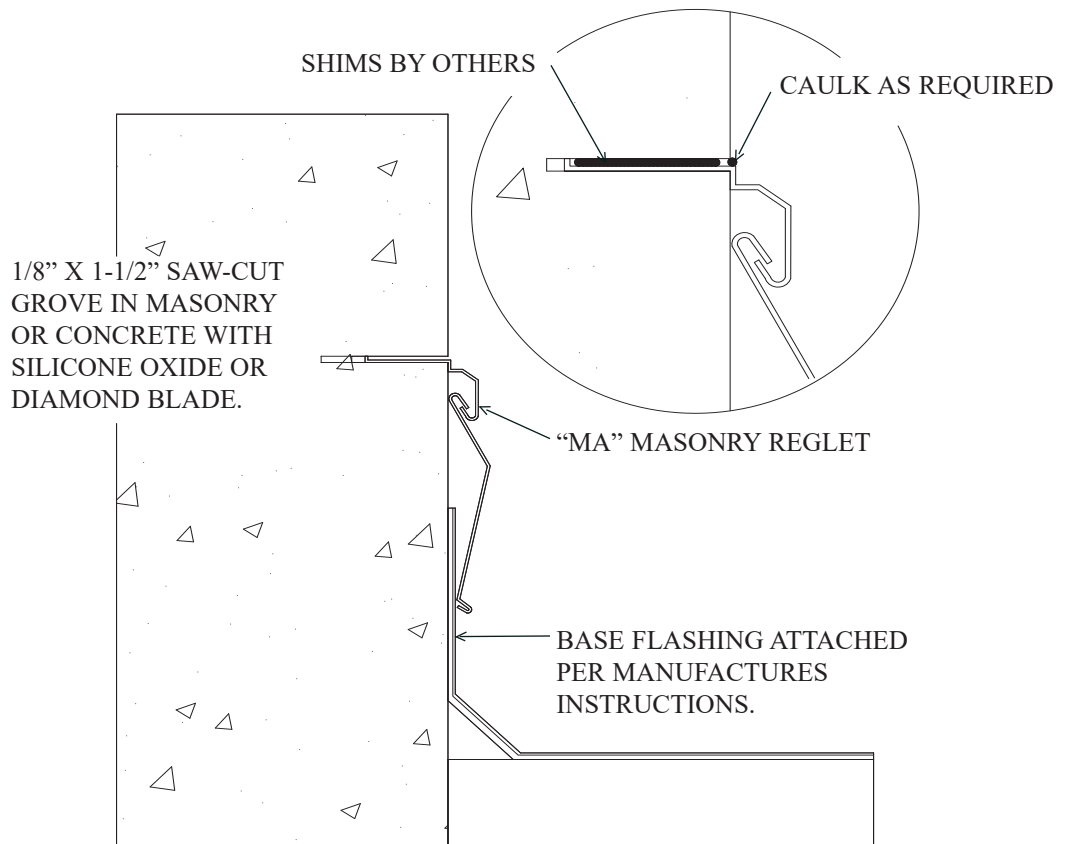

Fry Reglet Corp / 12342 Hawkins Street, Santa Fe Springs, CA 90670 / 562.903.9500 / fax 562.944.4707
1377 Stonefield Court, Alpharetta, GA 30004 / 770.521.9660 / fax 770.521.9034

IMPORTANT NOTICE: Information contained herein is believed to be reliable, but no representation, guarantees or warranties of any kind are made as to its accuracy, suitability for particular applications or the results to be obtained therefrom. Before using, user shall determine products suitability for users intended use and shall assume all risk and liability in connection therewith. FRY REGLET DISCLAIMS ALL WARRANTIES, EXPRESS OR IMPLIED, INCLUDING BUT NOT LIMITED TO ANY IMPLIED WARRANTIES OF MERCHANTABILITY OR FITNESS FOR A PARTICULAR USE.

Fry Reglet Springlok® Flashing System

Type: SM-Surface Mount

7/09-7

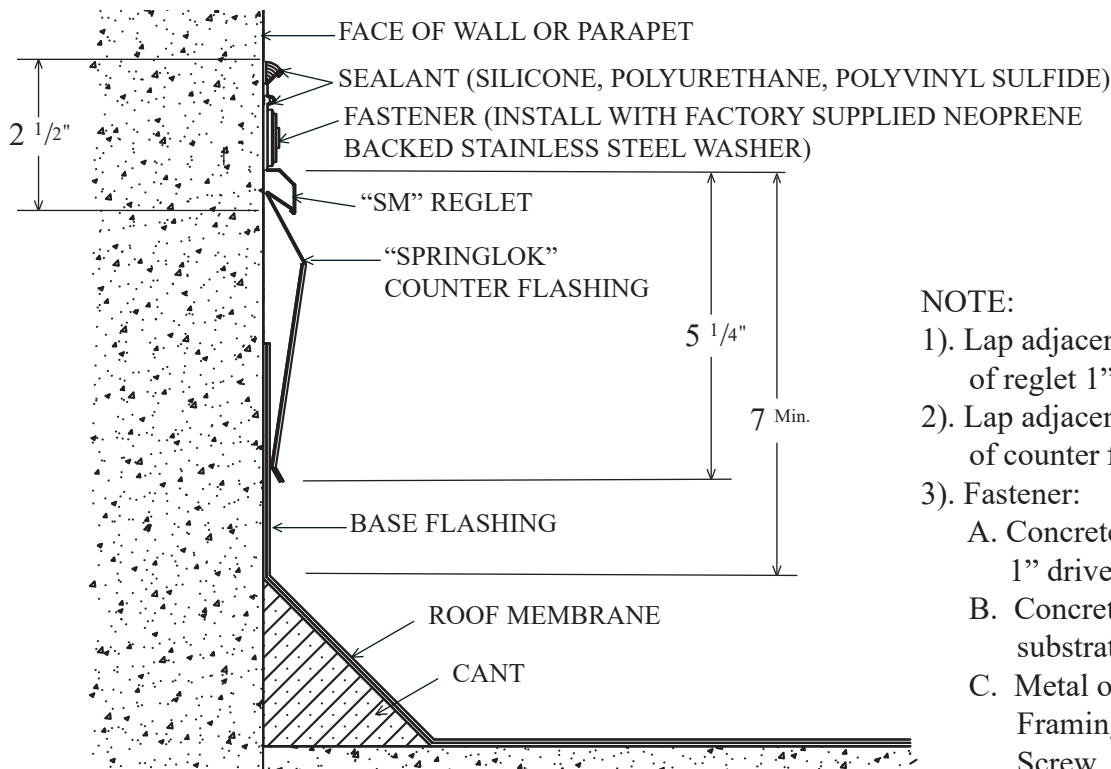

NOTE:

- 1). Lap adjacent lengths of reglet 1”.
- 2). Lap adjacent lengths of counter flashing 3”.
- 3). Fastener:
 - A. Concrete substrate only: 1” drive pin.
 - B. Concrete, brick or CMU substrate: rawl lite spike.
 - C. Metal or Wood Framing: #8 x 1” Tek Screw

Description: Reglet & counter flashing system (2 piece, spring-action type). Available in copper, stainless steel, aluminum & galvanized steel.

Application: SURFACE MOUNT (pre-cast concrete, tilt-up concrete and retrofit applications over concrete, brick and CMU). Requires sealant (silicon, polyurethane, or polyvinyl sulfide).

Special Features: Reglet supplied with neoprene-faced stainless steel washer for proper fastening.

Installation

General: 1). Install to heights on drawings; 2). Clean substrate thoroughly before installing flashing system; 3). Seal substrate before installing flashing system; 4). Install reglets, then counter flashings; 5) See instructions titled *Factory-Fabricated Corners* and *Lap Joint & End Cap Erection*.

Reglets: 1). Install factory fabricated inside & outside corners before installing straight lengths; 2). Place sealant in groove on rear face; 3). Place fastener through factory-drilled slot, and fasten in place; 4). Make sure that reglets are right side up; 5). Protect from damage during fastening; 6). Lap ends 1” at stamped offset; 7). Seal groove between top of reglet and wall; 8). Seal all laps.

Counter Flashings: 1). Verify that counter flashing is not bent or deformed, and that horizontal

Fry Reglet Corp / 12342 Hawkins Street, Santa Fe Springs, CA 90670 / 562.903.9500 / fax 562.944.4707
1377 Stonefield Court, Alpharetta, GA 30004 / 770.521.9660 / fax 770.521.9034

IMPORTANT NOTICE: Information contained herein is believed to be reliable, but no representation, guarantees or warranties of any kind are made as to its accuracy, suitability for particular applications or the results to be obtained therefrom. Before using, user shall determine products suitability for users intended use and shall assume all risk and liability in connection therewith. FRY REGLET DISCLAIMS ALL WARRANTIES, EXPRESS OR IMPLIED, INCLUDING BUT NOT LIMITED TO ANY IMPLIED WARRANTIES OF MERCHANTABILITY OR FITNESS FOR A PARTICULAR USE.

Fry Reglet Springlok® Flashing System

Type: SM-Surface Mount

7/09-8

Installation - cont.

dimension, measured from face of wall to apex of “V” shape of flashing, is 3/4” (dimension “A”); 2). Install factory mitered inside and outside corners before installing straight lengths; 3). Maintain constant horizontal pressure against face of wall, apply upward pressure with palm of hand until flashing snaps into reglet; 4). Lap 3” min.

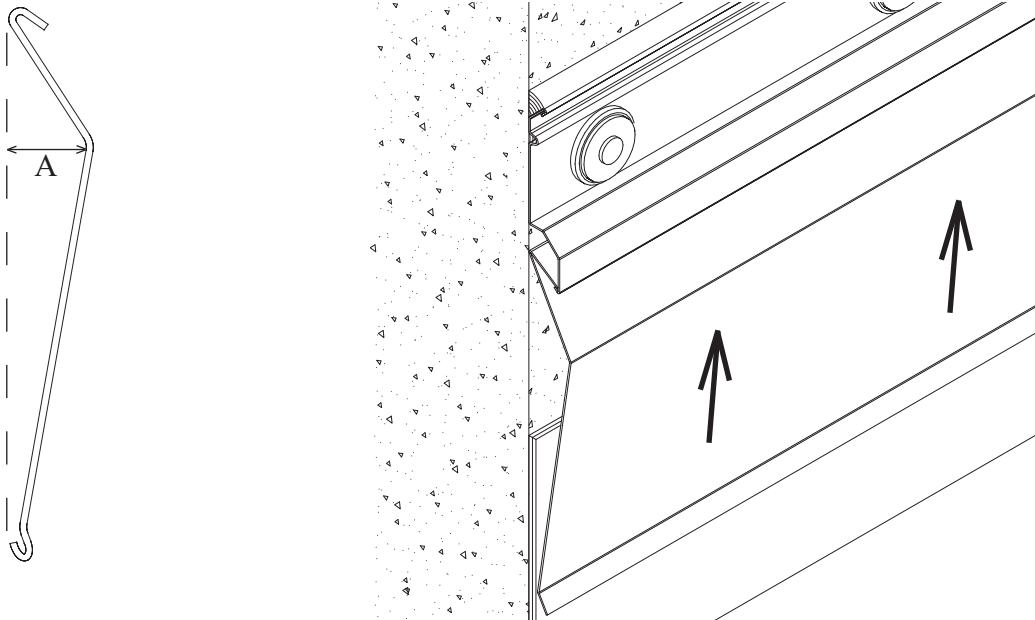

Counter Flashing Removal: 1). Insert putty knife at one end of counter flashing between counter flashing and reglet; 2). Apply slight pressure against counter flashing to force it away from face of reglet; 3). Press down on counter flashing to slide it out from under reglet.

Fry Reglet Corp / 12342 Hawkins Street, Santa Fe Springs, CA 90670 / 562.903.9500 / fax 562.944.4707
1377 Stonefield Court, Alpharetta, GA 30004 / 770.521.9660 / fax 770.521.9034

IMPORTANT NOTICE: Information contained herein is believed to be reliable, but no representation, guarantees or warranties of any kind are made as to its accuracy, suitability for particular applications or the results to be obtained therefrom. Before using, user shall determine products suitability for users intended use and shall assume all risk and liability in connection therewith. FRY REGLET DISCLAIMS ALL WARRANTIES, EXPRESS OR IMPLIED, INCLUDING BUT NOT LIMITED TO ANY IMPLIED WARRANTIES OF MERCHANTABILITY OR FITNESS FOR A PARTICULAR USE.

Type: ST-Stucco (With Counter Flashing Backer Board)

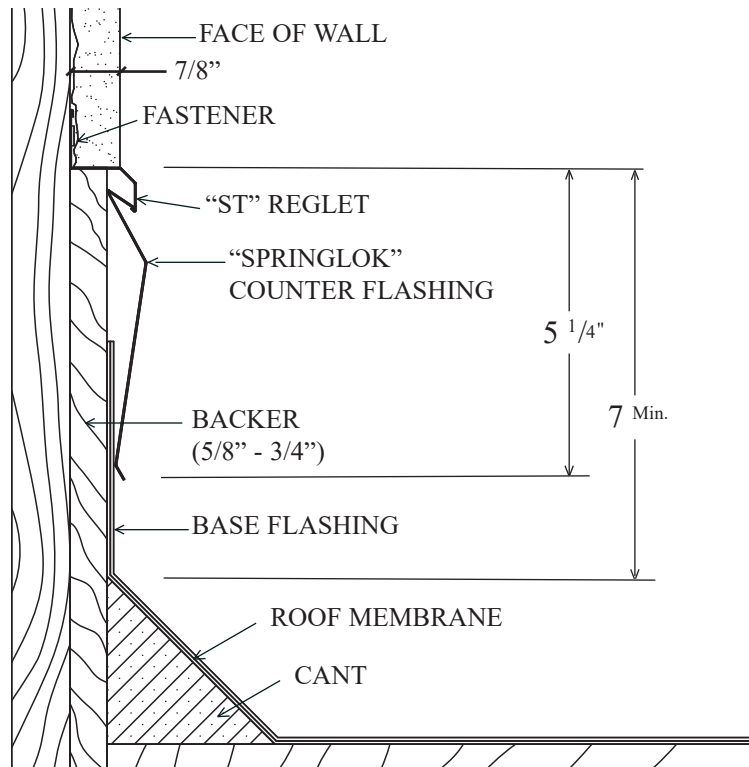

NOTE:

- 1). Lap adjacent lengths of reglet 1”.
- 2). Lap adjacent lengths of counter flashing 3”.
- 3). Fastener:
 - A. Concrete substrate only: 1” drive pin.
 - B. Concrete, brick or CMU substrate: rawl lite spike.
 - C. Metal or Wood Framing: #8 x 1” Tek Screw

Description: Reglet & counter flashing system (2 piece, spring-action type). Available in copper, stainless steel, aluminum & galvanized steel.

Application: Stucco. *Requires backer board.*

Installation

General: 1). Install to heights on drawings; 2). Install reglets, then counter flashings; 3). Install backer board to heights indicated for reglets before installing reglets; 4). Secure backer boards in place with approved fasteners; 5) See instructions titled *Factory-Fabricated Corners and Lap Joint & End Cap Erection*.

Reglets: 1). Install factory fabricated inside & outside corners before installing straight lengths; 2). Install reglets before lathing; 3). Make sure that reglets are right side up; 5). Be sure to install lathing and membrane so they will be able to lap vertical flange; 5). Install horizontal flange tight to top of backer board; 6). Lap ends 1” at stamped offset.

Counter Flashings: 1). Verify that counter flashing is not bent or deformed, and that horizontal

Type: ST-Stucco (With Counter Flashing Backer Board)

Installation - cont.

dimension, measured from face of wall to apex of “V” shape of flashing, is 3/4” (dimension “A”); 2). Install factory mitered inside and outside corners before installing straight lengths; 3). Maintain constant horizontal pressure against face of wall, apply upward pressure with palm of hand until flashing snaps into reglet; 4). Lap 3” min.

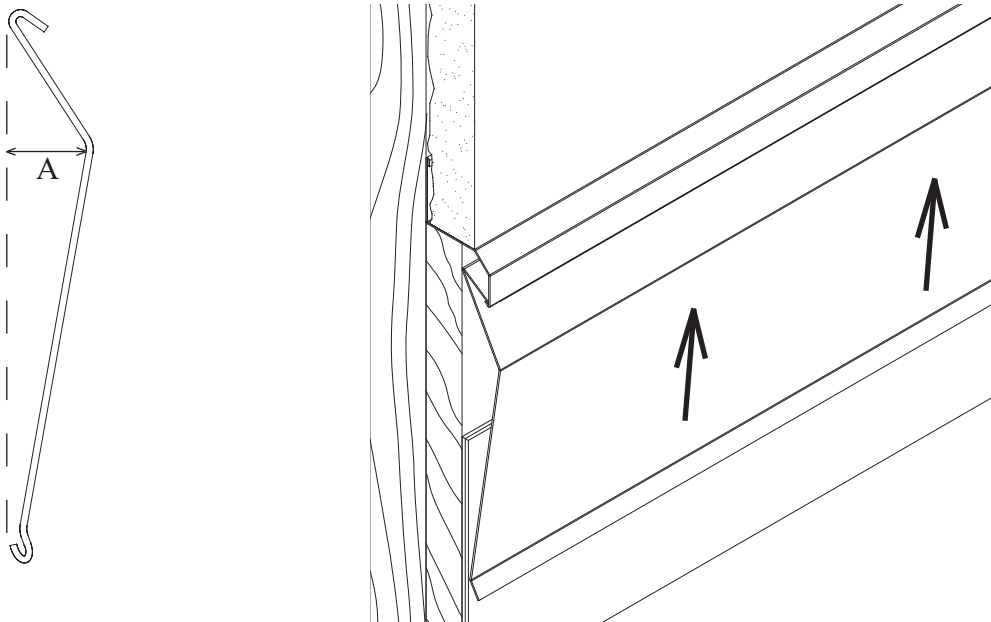

Counter Flashing Removal: 1). Insert putty knife at one end of counter flashing between counter flashing and reglet; 2). Apply slight pressure against counter flashing to force it away from face of reglet; 3). Press down on counter flashing to slide it out from under reglet.

Type: STX - Stucco (Backer Board NOT Required)

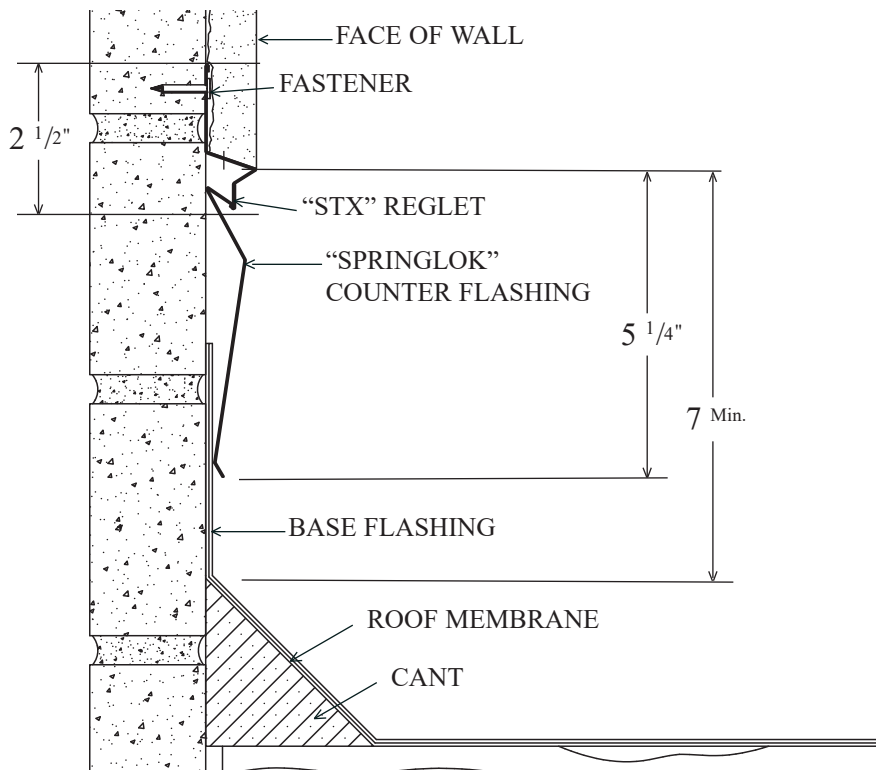

NOTE:

- 1). Lap adjacent lengths of reglet 1”.
- 2). Lap adjacent lengths of counter flashing 3”.
- 3). Fastener:
 - A. Concrete substrate only: 1” drive pin.
 - B. Concrete, brick or CMU substrate: rawl lite spike.
 - C. Metal or Wood Framing: #8 x 1” Tek Screw

Description: Reglet & counter flashing system (2 piece, spring-action type). Available in copper, stainless steel, aluminum & galvanized steel.

Application: Stucco.

Installation

General: 1). Install to heights on drawings; 2). Install reglets, then counter flashings.

Reglets: 1). Install factory fabricated inside & outside corners before installing straight lengths; 2). Install reglets before lathing; 3). Make sure that reglets are right side up; 4). Be sure to install lathing and membrane so they will be able to lap vertical flange; 5). Lap ends 1” at stamped offset.

Counter Flashings: 1). Verify that counter flashing is not bent or deformed, and that horizontal

Type: STX - Stucco (Backer Board NOT Required)

Installation - cont.

dimension, measured from face of wall to apex of “V” shape of flashing, is 3/4” (dimension “A”); 2). Install factory mitered inside and outside corners before installing straight lengths; 3). Maintain constant horizontal pressure against face of wall, apply upward pressure with palm of hand until flashing snaps into reglet; 4). Lap 3” min.

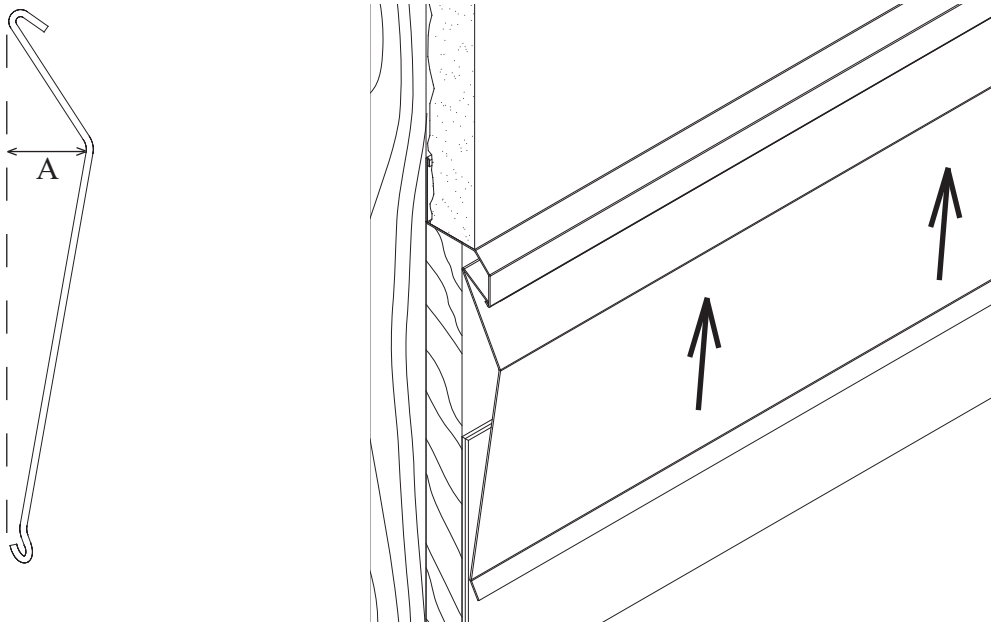

Counter Flashing Removal: 1). Insert putty knife at one end of counter flashing between counter flashing and reglet; 2). Apply slight pressure against counter flashing to force it away from face of reglet; 3). Press down on counter flashing to slide it out from under reglet.

Fry Reglet Springlok® Flashing System Factory Fabricated Corners

7/09-13

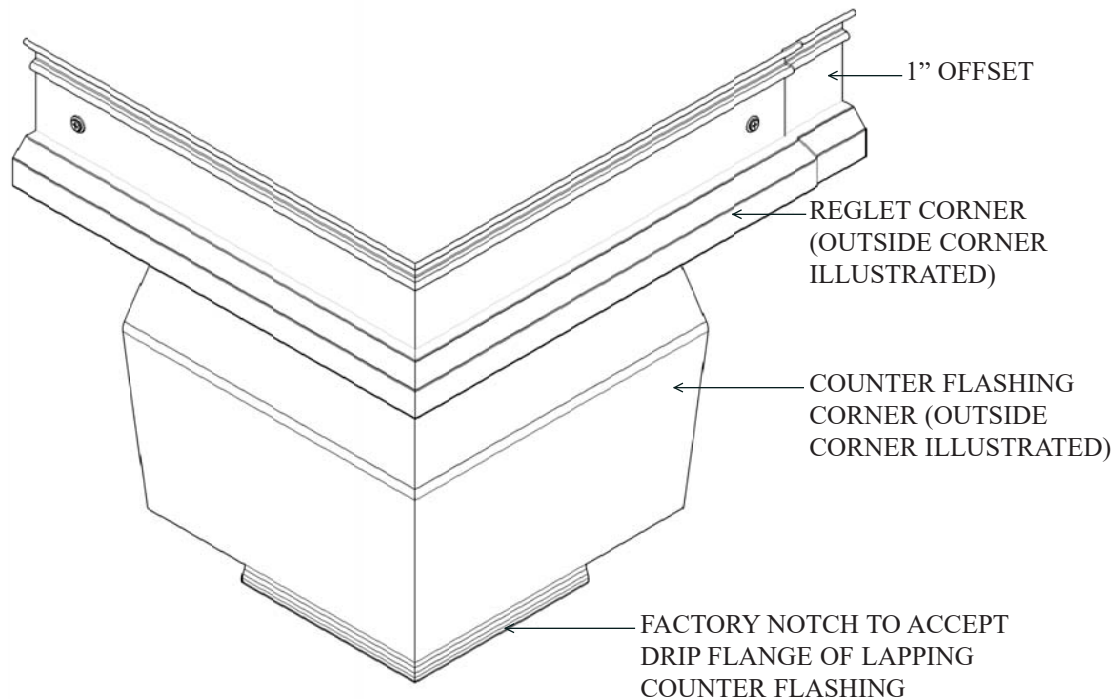

“SM” REGLET ILLUSTRATED

Description: Mitered & factory-welded inside & outside corners. Available for all system types (CO, MA, ST, SM & STX). Available in copper, stainless steel galvanized steel. ***Not available in aluminum.***

Aluminum Systems: When installing aluminum straight lengths, use stainless steel corners.

Application: All Systems & All Corners (Inside & Outside). Type SM outside corner only is shown above.

90- Degree Corners: Standard for all Springlok® Flashing Systems.

Acute & Obtuse Intersections: Available by special order.

Installation

General: 1). Install at all corners; 2). Install to heights on drawings; 3). Install prior to installing straight lengths.

Reglets: 1). Install in accordance with procedures recommended for particular system.

Counter Flashings: 1). Install in accordance with procedures recommended for particular system.

Fry Reglet Corp / 12342 Hawkins Street, Santa Fe Springs, CA 90670 / 562.903.9500 / fax 562.944.4707
1377 Stonefield Court, Alpharetta, GA 30004 / 770.521.9660 / fax 770.521.9034

IMPORTANT NOTICE: Information contained herein is believed to be reliable, but no representation, guarantees or warranties of any kind are made as to its accuracy, suitability for particular applications or the results to be obtained therefrom. Before using, user shall determine products suitability for users intended use and shall assume all risk and liability in connection therewith. FRY REGLET DISCLAIMS ALL WARRANTIES, EXPRESS OR IMPLIED, INCLUDING BUT NOT LIMITED TO ANY IMPLIED WARRANTIES OF MERCHANTABILITY OR FITNESS FOR A PARTICULAR USE.

Fry Reglet Springlok® Flashing System Factory Fabricated Corners

7/09-14

Installation - cont.

2). Secure overlapping straight length to leg of counter flashing corner with pop rivet (or screw), as shown.

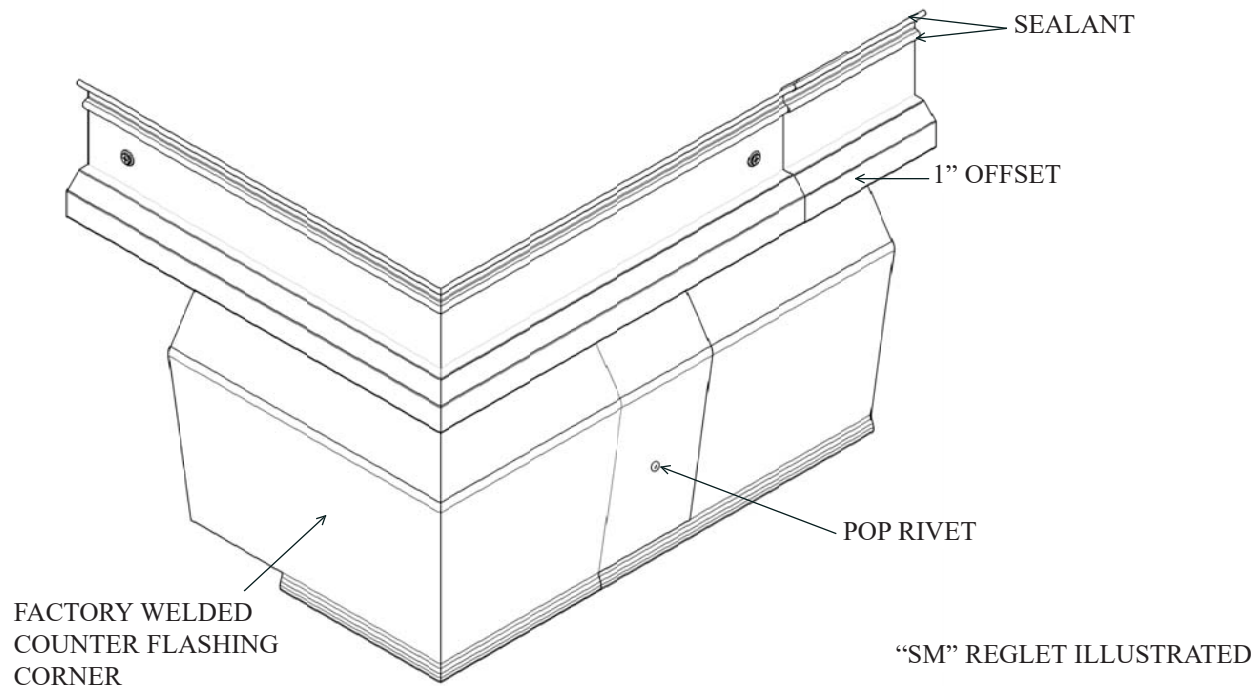
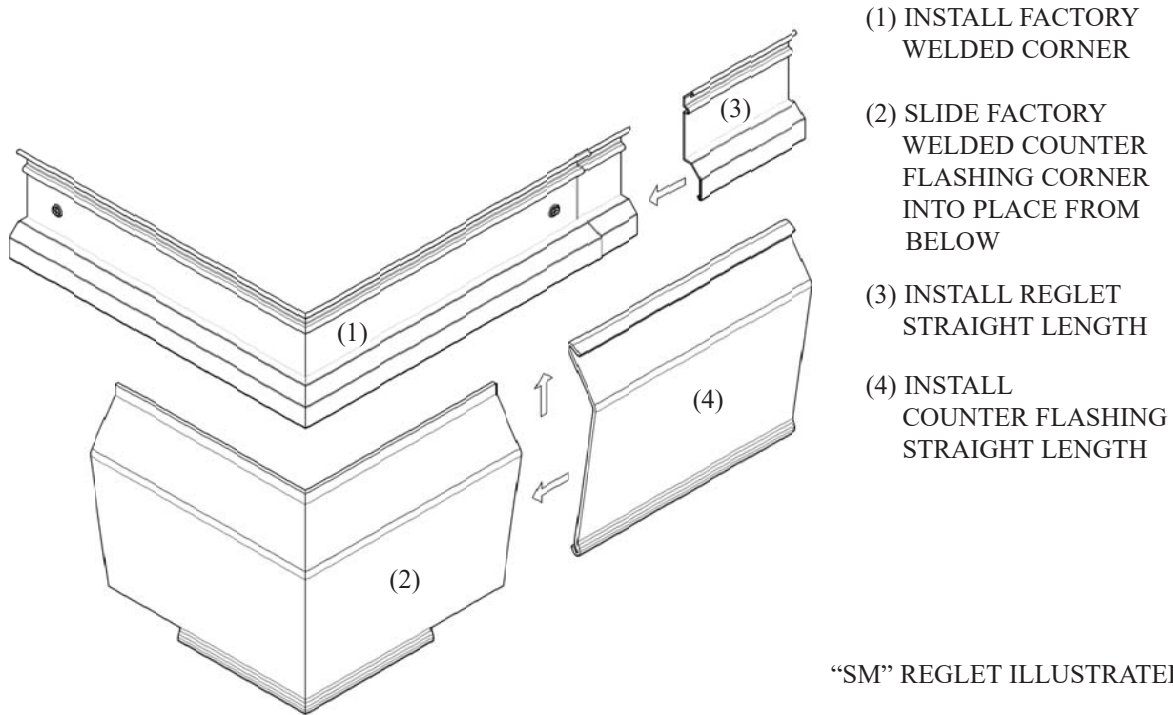

Fry Reglet Corp / 12342 Hawkins Street, Santa Fe Springs, CA 90670 / 562.903.9500 / fax 562.944.4707
1377 Stonefield Court, Alpharetta, GA 30004 / 770.521.9660 / fax 770.521.9034

IMPORTANT NOTICE: Information contained herein is believed to be reliable, but no representation, guarantees or warranties of any kind are made as to its accuracy, suitability for particular applications or the results to be obtained therefrom. Before using, user shall determine products suitability for users intended use and shall assume all risk and liability in connection therewith. FRY REGLET DISCLAIMS ALL WARRANTIES, EXPRESS OR IMPLIED, INCLUDING BUT NOT LIMITED TO ANY IMPLIED WARRANTIES OF MERCHANTABILITY OR FITNESS FOR A PARTICULAR USE.

Fry Reglet Springlok® Flashing System Lap Joint

7/09-15

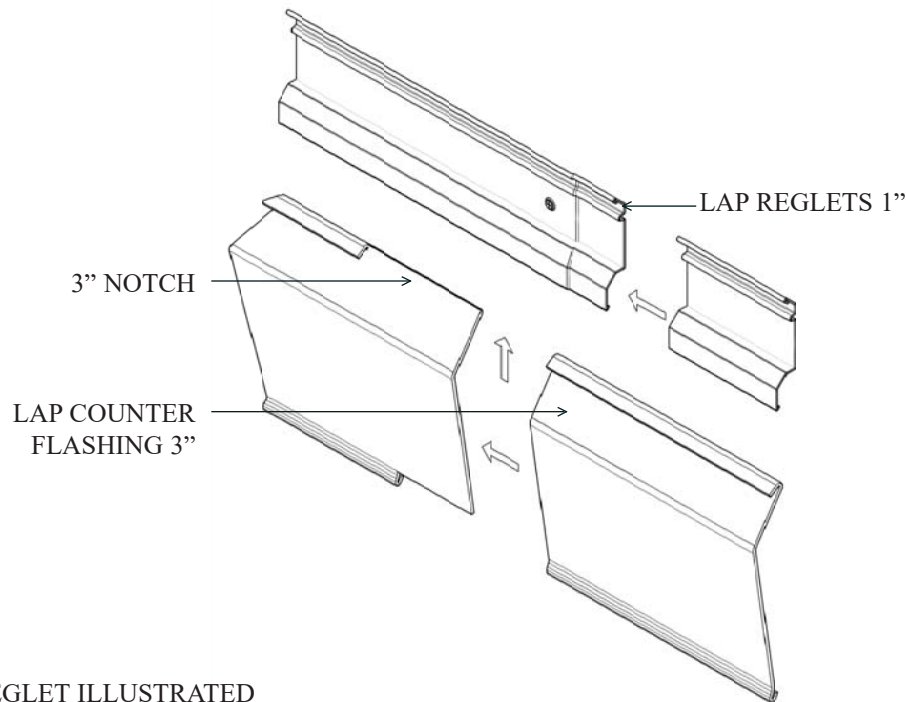

“SM” REGLET ILLUSTRATED

Description: For all systems, counter flashings are supplied with a 3” notch. The lap joint is field-assembled using this notch, and, in reglet types MA, SM, ST & STX, a 1” stamped offset. Type CO reglet has no offset; it forms a tight-fitting butt joint. When installing Type CO reglets, only the counter flashings laps.

Application: All joints between straight lengths.

Erection

General: 1). When trimming reglet and counter flashing straight lengths to fit, do not cut ends that have been factory formed for lapping; 2). The offset (in reglet lengths) and notch (in counter flashing lengths) are located at the right end.

Reglets: 1). Carefully install so that overlapping end fits securely over offset; 2). Seal all laps.

Counter Flashings: 1). Carefully install so that overlapping end fits securely into notch; Seal all laps.

Fry Reglet Corp / 12342 Hawkins Street, Santa Fe Springs, CA 90670 / 562.903.9500 / fax 562.944.4707
1377 Stonefield Court, Alpharetta, GA 30004 / 770.521.9660 / fax 770.521.9034

IMPORTANT NOTICE: Information contained herein is believed to be reliable, but no representation, guarantees or warranties of any kind are made as to its accuracy, suitability for particular applications or the results to be obtained therefrom. Before using, user shall determine products suitability for users intended use and shall assume all risk and liability in connection therewith. FRY REGLET DISCLAIMS ALL WARRANTIES, EXPRESS OR IMPLIED, INCLUDING BUT NOT LIMITED TO ANY IMPLIED WARRANTIES OF MERCHANTABILITY OR FITNESS FOR A PARTICULAR USE.

Fry Reglet Springlok® Flashing System End Cap

7/09-16

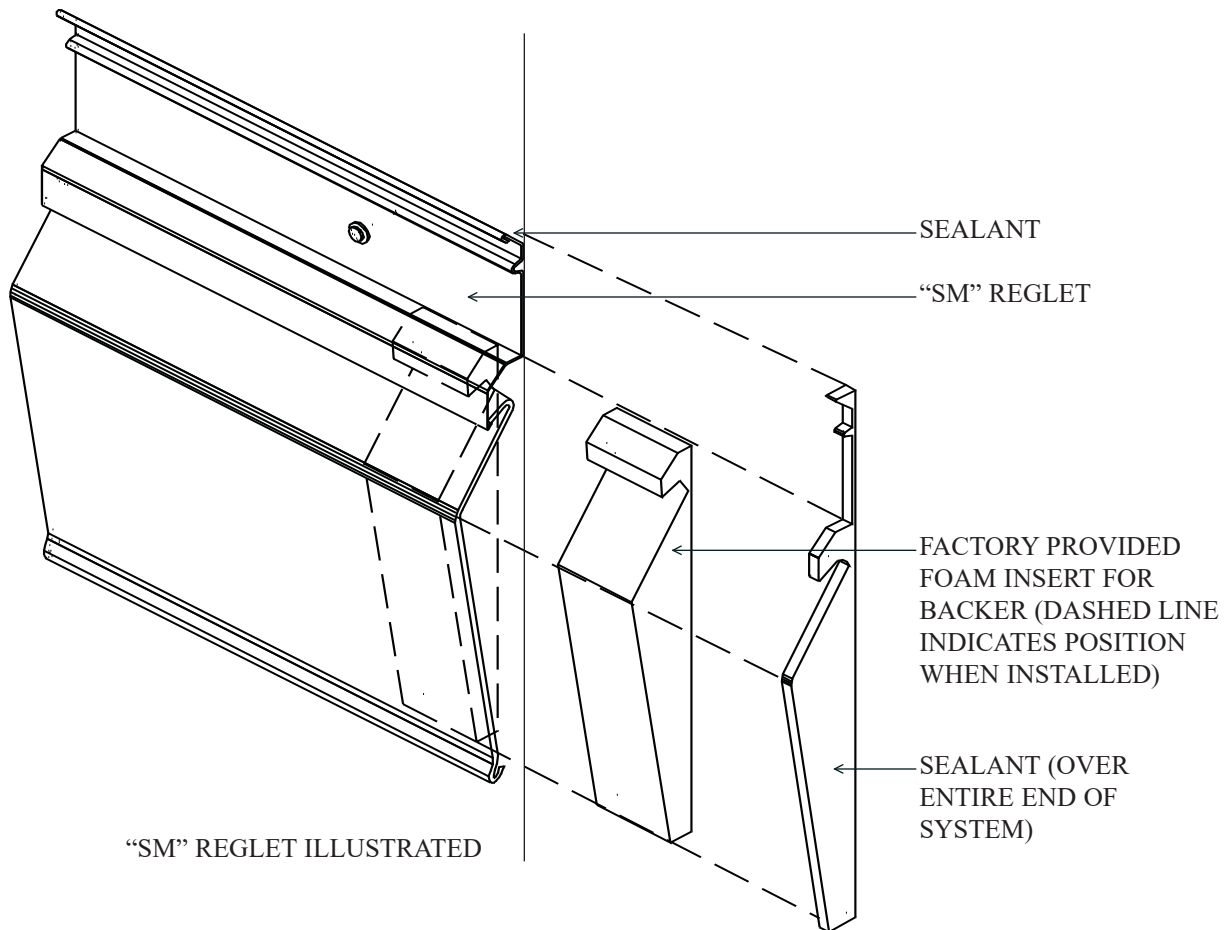

Description: The end-cap is field-erected using a factory-provided foam insert. This insert is available for all systems. It functions as a backer for sealant.

Application: All Systems, where reglet and flashing system is terminated or is discontinuous. Requires sealant (silicon, polyurethane, or polyvinyl sulfide).

Installation

General: 1). Insert factory-provided 1” wide foam insert into space behind flashing system at end of flashing system; 2). Exposed face of foam insert should be 1/8” - 1/4” inside end of flashing system; 3). Make sure that insert is snugly in place, and fills gap behind both counter flashing and reglet; 4). Using foam insert as sealant backer, thoroughly seal end of run, making sure that entire exposed end of flashing system is sealed.

Fry Reglet Corp / 12342 Hawkins Street, Santa Fe Springs, CA 90670 / 562.903.9500 / fax 562.944.4707
1377 Stonefield Court, Alpharetta, GA 30004 / 770.521.9660 / fax 770.521.9034

IMPORTANT NOTICE: Information contained herein is believed to be reliable, but no representation, guarantees or warranties of any kind are made as to its accuracy, suitability for particular applications or the results to be obtained therefrom. Before using, user shall determine products suitability for users intended use and shall assume all risk and liability in connection therewith. FRY REGLET DISCLAIMS ALL WARRANTIES, EXPRESS OR IMPLIED, INCLUDING BUT NOT LIMITED TO ANY IMPLIED WARRANTIES OF MERCHANTABILITY OR FITNESS FOR A PARTICULAR USE.

Fry Reglet Springlok® Flashing System Windlok Clip & Vinylok Flashing Retainer

7/09-17

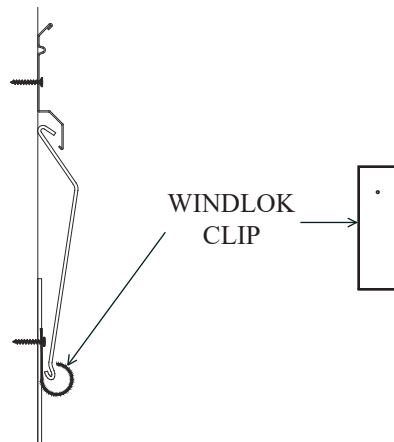

Windlok Clip

Description: Pre-drilled 1- 1/4" X 2- 1/2" metal strap designed to improve flashing performance during high winds by locking in place lower edge of flashing. Suitable for use with all system types (CO, MA, SM, ST & STX). Available in stainless steel.

Application: HIGH WIND CONDITIONS.

Spacing: Windlok Clip is not continuous. Install 30" O.C. max. along length of counter flashing, 6" max. from counter flashing ends.

Installation

General: 1). Install reglets to heights on drawings; 2). Measuring from lower edge of reglet, carefully establish the line where lower edge of counter flashing will be (after counter flashing is installed; 3). Before installing counter flashing, fasten Windlok Clips to wall or parapet with approved fasteners through pre-drilled holes, making sure that fasteners are located 1- 1/2" to 1- 3/4" above this line; 4). After counter flashing is installed, bend lower edge of Windlok Clip tightly up and around lower edge of counter flashing to secure this edge in place.

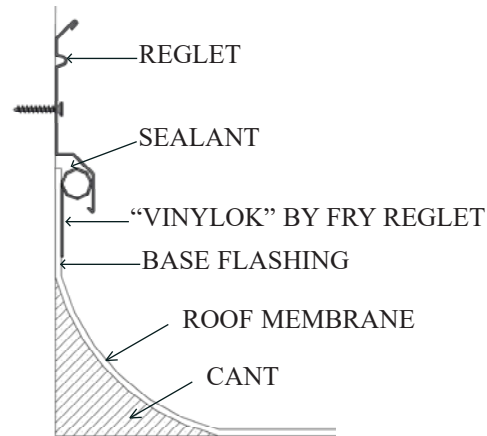

Vinylok Flashing Retainer

Description: Extruded polyvinyl chloride insert designed to secure base flashing in reglet where available height is limited and Springlok® Flashing System counter flashing is not feasible. Suitable for use with system types (MA, SM, ST & STX) only.

Application: AT BULKHEAD DOORS AND OTHER CONDITIONS WHERE HEIGHT RESTRICTIONS PROHIBIT USE OF METAL SPRINGLOK® FLASHING SYSTEM COUNTER FLASHINGS.

Installation

General: 1). Install flashing (composition base flashing or other) fully into reglet; 2). Install continuous length of Vinylok Flashing Retainer up into reglet opening between flashing and reglet lip, bulb-end first with "tail" against flashing; 3). Carefully press into place, making sure that flashing and Vinylok Flashing retainer are fully inserted in reglet opening.

Fry Reglet Corp / 12342 Hawkins Street, Santa Fe Springs, CA 90670 / 562.903.9500 / fax 562.944.4707
1377 Stonefield Court, Alpharetta, GA 30004 / 770.521.9660 / fax 770.521.9034

IMPORTANT NOTICE: Information contained herein is believed to be reliable, but no representation, guarantees or warranties of any kind are made as to its accuracy, suitability for particular applications or the results to be obtained therefrom. Before using, user shall determine products suitability for users intended use and shall assume all risk and liability in connection therewith. FRY REGLET DISCLAIMS ALL WARRANTIES, EXPRESS OR IMPLIED, INCLUDING BUT NOT LIMITED TO ANY IMPLIED WARRANTIES OF MERCHANTABILITY OR FITNESS FOR A PARTICULAR USE.