



We
protect
what
matters
most™

A Guide to Cold Storage Roof System Design

Prepared by GAF Technical Services
June, 2020

Table of Contents

Page

Introduction

About GAF	2
About Cold Storage Buildings	2
Important Considerations	3

Guarantee Program

Guarantee Lengths	4
-------------------	---

Fundamentals of Moisture Control

Vapor Drive	7
Condensation Control	8
Air Leakage vs. Vapor Diffusion	8

Cold Storage Design Considerations

Basic Concept of Cold Storage Design	10
Design Considerations	10
Building Location	12
Design Values	13
Roof Insulation	13
Thermal Shorts/Thermal Bridging	13
Expansion and Contraction	14
Temperature Pull Down	15
Air Leakage and Water Vapor Movement	15
Vapor Retarder Perm Ratings	16

Application Guidelines for Roof Systems on Cold Storage Buildings

17

Roofing Details

Cold to Warm Transition Detail	18
Coated Metal Roof Edge Detail	19
Gravel Stop Coated Metal Roof Edge Detail	20
Gravel Stop Metal Roof Edge With Cover Tape Detail	21
Metal Roof Edge With Cover Tape Detail	22
Snap On Fascia Detail	23
Gutter With Coated Metal Roof Edge	24
Gutter With Metal Roof Edge and Cover Tape Detail	25
Wall Flashing With Counterflashing Detail	26
Wall/Curb Flashing with Termination Bar Detail	27
Through Wall Scupper With Coated Metal	28
Factory Fabricated Expansion Joint - Flat Type (TPO Only)	29
Premolded Vent Boot Flashing Detail	30

Introduction

Thank you for consulting A Guide to Cold Storage Roof System Design. You can find further information at www.gaf.com, or contact GAF Technical Support Services at 800-766-3411.

This Guide serves as a supplement to the EverGuard® TPO/PVC Adhered Roofing System Overview & General Requirements Manual, EverGuard® TPO/PVC Mechanically Attached Roofing System Overview & General Requirements Manual and Drill-Tec™ RhinoBond® Attachment System Overview & General Requirements Manual.

About GAF

Founded in 1886, GAF is the largest roofing manufacturer in North America.

As the industry leader, GAF proudly offers a comprehensive portfolio of award-winning, innovative roofing products for both steep-slope and commercial properties. Supported by an extensive national network of factory-certified contractors, GAF has built its reputation – and its success – on its steadfast commitment to Advanced Quality, Industry Expertise, and Solutions Made Simple.

GAF offers all major low-slope roofing technologies, including repair and maintenance products and roof restoration systems, as well as new roofing systems (BUR, modified bitumen, TPO, PVC, and liquid-applied roofing membranes). GAF has developed single-ply, asphaltic and liquid-applied membranes with excellent durability to meet the most rigorous industry standards.

For more information, visit www.gaf.com.

About Cold Storage Buildings

GAF defines cold storage as a building or portion of a building or structure designed to promote extended shelf life of products or commodities and typically has year-round temperatures below 50° F (10° C). It is the responsibility of the design professional to specify the cold storage building type and its roofing system.

Extremes in internal temperature and humidity are often associated with cold storage, freezer buildings, and food processing plants. What makes these types of buildings unusual is that the marked difference in vapor pressure between the building interior and the exterior can cause a pronounced vapor drive through the roof assembly. This can result in a significant build-up of condensation within the roof assembly and/or inside the building if the roofing system is not properly designed and installed, which can lead to severe deterioration of both the roof assembly itself and the structural deck.

Important Considerations

The purpose of this Guide is to provide important considerations for roofing systems installed over cold storage buildings.

This Guide serves as a supplement to the EverGuard® TPO/PVC Adhered Roofing System Overview & General Requirements Manual, EverGuard® TPO/PVC Mechanically Attached Roofing System Overview & General Requirements Manual, and Drill-Tec™ RhinoBond® Attachment System Overview & General Requirements Manual.

This Guide contains the latest information relating to the application of GAF's EverGuard® TPO/PVC Adhered Roofing Systems, EverGuard® TPO/PVC Mechanically Attached Roofing Systems, and Drill-Tec™ RhinoBond® Attachment Systems over cold storage buildings and is based on our experience in commercial roofing industry. It has been prepared as a general guide to assist architects, engineers, general contractors, project managers, roofing contractors, and owners in the use of our roofing systems.

GAF manufactures and sells roofing materials and does not practice architecture or engineering. GAF is not responsible for the performance of its products when damage to its products is caused by such things as improper building design, construction flaws, or defects in workmanship.

The design responsibility remains with the architect, engineer, roofing contractor, or owner. These guidelines should not be construed as being all-inclusive, nor should they be considered as a substitute for good application practices. Please consult your design professional for more information.

The guidelines contained herein are for information purposes only, and are not intended as a substitute for independent evaluation by the building owner or its consultants to determine with certainty whether a particular roofing system is suitable for the specific needs of a cold storage building. GAF makes no representation or warranty (express or implied) as to the suitability of its roofing systems for cold storage buildings.

Under no circumstances shall GAF have any liability for expenses arising out of or associated with the pre-existing presence of asbestos-containing materials or any other allegedly hazardous substances or materials upon the roof to which the new GAF roofing materials are being applied.

Information contained in this Guide is presented in good faith and, to the best of GAF's knowledge, does not infringe upon any patents, foreign or domestic.

As a part of its continuing efforts to improve the performance of its products, GAF periodically makes changes to its products and application specifications. The Company reserves the right to change or modify, at its discretion, any of the information, requirements, specifications, or policies contained herein. This Guide supersedes all catalogs and previous manuals.

Guarantee Program

GAF offers roof guarantees for a fee for approved roofing system specifications when installed by GAF Factory-Certified Low-Slope Roofing Contractors in accordance with the terms and conditions set forth in the EverGuard® TPO/PVC Adhered Roofing System Overview & General Requirements Manual, EverGuard® TPO/PVC Mechanically Attached Roofing System Overview & General Requirements Manual, and Drill-Tec™ RhinoBond® Attachment Systems, provided that all standard requirements for guarantee issuance are met.

GAF's limited warranties and system guarantees do not cover damages resulting from vapor drive through or condensation within the roof assembly unless specifically provided through an air barrier/vapor seal addendum. This addendum can be obtained for eligible projects for a fee. Contact GAF for requirements and complete coverage.

All guaranteed roofing systems must be flashed in accordance with published GAF flashing requirements and details. All GAF insulation, fasteners, pre-flashed details, expansion joint covers, cements, coatings, and accessory products as job-appropriate are required for guarantees unless otherwise approved in writing by a Field Services Manager or Director prior to installation.

GAF will be the sole judge as to whether a guarantee will be issued to cover any proposed or completed roof. The issuance of a guarantee and its effectiveness is contingent upon payment of GAF's guarantee fee and payment in full to contractors and materials suppliers.

GAF has no obligation to issue a roofing guarantee on any roof. Any inspection conducted by GAF in connection with the issuance or administration of the guarantee is **solely** for the benefit of GAF and does not constitute a waiver of any terms or conditions in the guarantee. In the event that a roof system does not conform to GAF's standards and a guarantee is not issued, no portion of the guarantee fee is refundable.

GAF will not accept Notices of Award of Contract that indicate that the owner or architect has the option to accept or reject the guarantee upon completion of the roof.

GAF is not responsible for consequential damages in case of roof system failure. GAF has no control over a building's contents, type, quantity, positioning, or protection.

Requirements for Diamond Pledge™ Guarantee Coverage

Cold storage buildings require proper design, quality materials, and good workmanship under close supervision. Proper roofing system design and selection requires careful consideration of factors specific to cold storage. Materials should be compatible with each other. Only properly trained and professionally equipped roofing contractors experienced in the installation of TPO and PVC roofing application should install these systems over cold storage buildings. The coordination and cooperation of the general, roofing, and other relevant contractors will contribute to a successful installation.

GAF will issue a guarantee only for roofing systems applied by a GAF Factory-Certified Low-Slope Roof Contractor. The roofing system must be installed in accordance to the shop drawings reviewed by GAF. There must be no deviations made without prior written consent by GAF.

At the completion of the roofing system installation, an inspection will be conducted by a GAF Field Service Representative to determine the roofing system was been installed in accordance with GAF's specifications and construction details.

A continuous and uninterrupted vapor retarder/air barrier system must encompass the building envelope to prevent warm, moisture-laden air from entering the roof assembly at the perimeter and penetrations. There should be vapor retarder/air barrier continuity from one surface to another, i.e., roof-to-wall, wall-to-floor. With freezer buildings, the vapor retarder located below the floor slab should be sealed at the floor-to-wall interface to prevent air leakage.

Temperature pull-down must be followed to minimize construction moisture problems.

For further information on guarantee requirements and for approval of modifications to published specifications, consult with GAF at 800-766-3411.

Guarantees Lengths

GAF offers an extensive selection of roof guarantees to meet the needs of most building owners. The following guarantees are available for use with selected EverGuard® TPO/PVC Roofing Systems when installed by an eligible GAF Factory-Certified Low-Slope Roofing Contractor. **The maximum roof system guarantee length for cold storage buildings is 20 years.**

GAF's guarantee does not cover damage resulting from any third-party products or systems which are attached to or through GAF's EverGuard® TPO, EverGuard Extreme® TPO or EverGuard® PVC membranes. See guarantee for complete coverage and restrictions.

Available Guarantee Coverage for TPO and PVC Installations on Cold Storage Buildings

System Attachment	Maximum Guarantee Length	TPO	PVC
Adhered	20 yr.	<ul style="list-style-type: none"> ▪ EverGuard® 60 and 80 mil (Smooth) ▪ EverGuard® 60 and 80 mil (Fleece) ▪ EverGuard Extreme® 60, 70 and 80 mil (Smooth) ▪ EverGuard Extreme® 60, 70 and 80 mil (Fleece) 	<ul style="list-style-type: none"> ▪ EverGuard® 60 and 80 mil (Smooth) ▪ EverGuard® 60 and 80 mil (Fleece) ▪ EverGuard® KEE 50, 60 and 80 mil (Smooth) ▪ EverGuard® KEE 50, 60 and 80 mil (Fleece)
Mechanically Attached	20 yr.	<ul style="list-style-type: none"> ▪ EverGuard® 60 and 80 mil (Smooth) ▪ EverGuard Extreme® 60, 70 and 80 mil (Smooth) 	<ul style="list-style-type: none"> ▪ EverGuard® 60 and 80 mil (Smooth) ▪ EverGuard® KEE 50, 60 and 80 mil (Smooth)
Drill-Tec™ RhinoBond® Attachment	20 yr.	<ul style="list-style-type: none"> ▪ EverGuard® 60 and 80 mil (Smooth) ▪ EverGuard Extreme® 60, 70 and 80 mil (Smooth) 	<ul style="list-style-type: none"> ▪ EverGuard® 60 and 80 mil (Smooth) ▪ EverGuard® KEE 50, 60 and 80 mil (Smooth)

The following requirements and restrictions apply:

1. Available for new and tear-off systems only. Not available for recover systems.
2. **Minimum 2 layers of insulation are required.** For adhered membrane roofing systems, the top layer of insulation must be adhered and must be an approved cover board.
3. Best roofing practices must be followed. Building envelope specifications provided by the designer for sealing of all penetrations and roof-to-wall interfaces must be followed.
4. EverGuard® TPO accessories must be used with EverGuard® TPO systems only.
5. EverGuard Extreme® TPO accessories must be used with EverGuard Extreme® TPO systems only.
6. EverGuard® PVC accessories must be used with EverGuard® PVC systems only.
7. An inspection will be required after all work is completed.
8. For additional information on cold storage installations, please consult GAF Technical Services.

Fundamentals of Moisture Control

There are design considerations that are unique to cold storage buildings. In order to understand some of the important design concerns, it helps to be familiar with the following moisture control fundamentals:

- Vapor drive
- Condensation control
- Air leakage vs. vapor diffusion

One of the primary purposes of a building envelope is to keep moisture out of a building. What makes this difficult is that it comes in many forms and can take many paths into a building. Building designers need to account for bulk water, capillary water, air-transported moisture, and water vapor, and defend against each of these in different ways.

Bulk water (i.e., rain and snow) is kept out of buildings with roof membranes and wall cladding systems. Capillary water is primarily a ground-based issue involving water moving into and through the building envelope via capillary action. Foundation waterproofing and water barrier layers or components are used to prevent this intrusion. Air-transported water, as the name implies, is carried into or out of a building by air that infiltrates or passes through the building envelope. Water vapor enters or exits a building by the process of diffusion through the building envelope materials.

There is one simple rule that defines how heat, air, and moisture move—the second law of thermodynamics. In terms of building and roofing science, this means:

- Hot moves to cold
- Moist moves to dry
- High pressure moves to low pressure

Heat, moisture, and pressure always equalize when possible.

Vapor drive

For conventional buildings, warm, moist inside air moves outward during the colder winter months. Therefore, the direction of the vapor drive is from the interior to the exterior.

Cold storage buildings commonly are maintained at temperatures that are considerably lower than the exterior temperature. So for cold storage buildings, the warm, moist outside air moves inward. This is especially the case in southern climates, and is generally true for most geographic locations in the US for most months of the year. Therefore, the direction of the vapor drive is from the exterior to the interior.

Condensation control

A common way to control or minimize condensation problems in a roofing assembly is to use a vapor retarder. Vapor retarders help reduce water vapor diffusion into a roof system. The most familiar use of vapor retarders are in buildings located in colder climates and for buildings with high interior humidity levels, such as swimming pools, museums and data centers. For these scenarios, the most effective location for a vapor retarder is directly above the roof deck and below the roof insulation layer(s), or in some cases, directly above a rigid board (e.g., gypsum board) that is secured to the roof deck. In other words, the vapor retarder is installed on the warm side (in winter) of the insulation.

For cold storage buildings, the same principal applies. Because the vapor drive is from the exterior to the interior, however, the vapor retarder is located on the outside of the insulation. Most commonly, the roof membrane serves as the vapor retarder. This is certainly the case for cold storage buildings located in very warm climates, and is true for most geographic locations in the US for most months of the year.

Air leakage vs. vapor diffusion

Air-transported moisture is a bigger issue than vapor diffusion, because of the comparative amount of moisture transported during each process.

The National Research Council Canada collected research data that illustrated how even small openings can affect overall air leakage performance. For example, only about 1/3 of a quart of water will diffuse through a continuous 4 ft. by 8 ft. sheet of gypsum during a one-month period even though gypsum board has a very high permeance.

However, if there is a 1-square-inch hole in this same sheet of gypsum, about 30 quarts of water can pass through the opening as a result of air leakage. This relationship is illustrated in Figure 1. This example illustrates that air leakage can cause more moisture-related problems than vapor diffusion.

Accordingly, it is critical that vapor retarder systems be continuous when used in cold storage buildings. Laps, penetrations and the roof-to-wall interfaces should be sealed to prevent air leakage because discontinuity will lead to condensation problems. Again, most commonly, the roof membrane serves as the vapor retarder.

Another way of looking at it is that a vapor retarder is also serving as an air barrier because it is installed to block the passage of air.

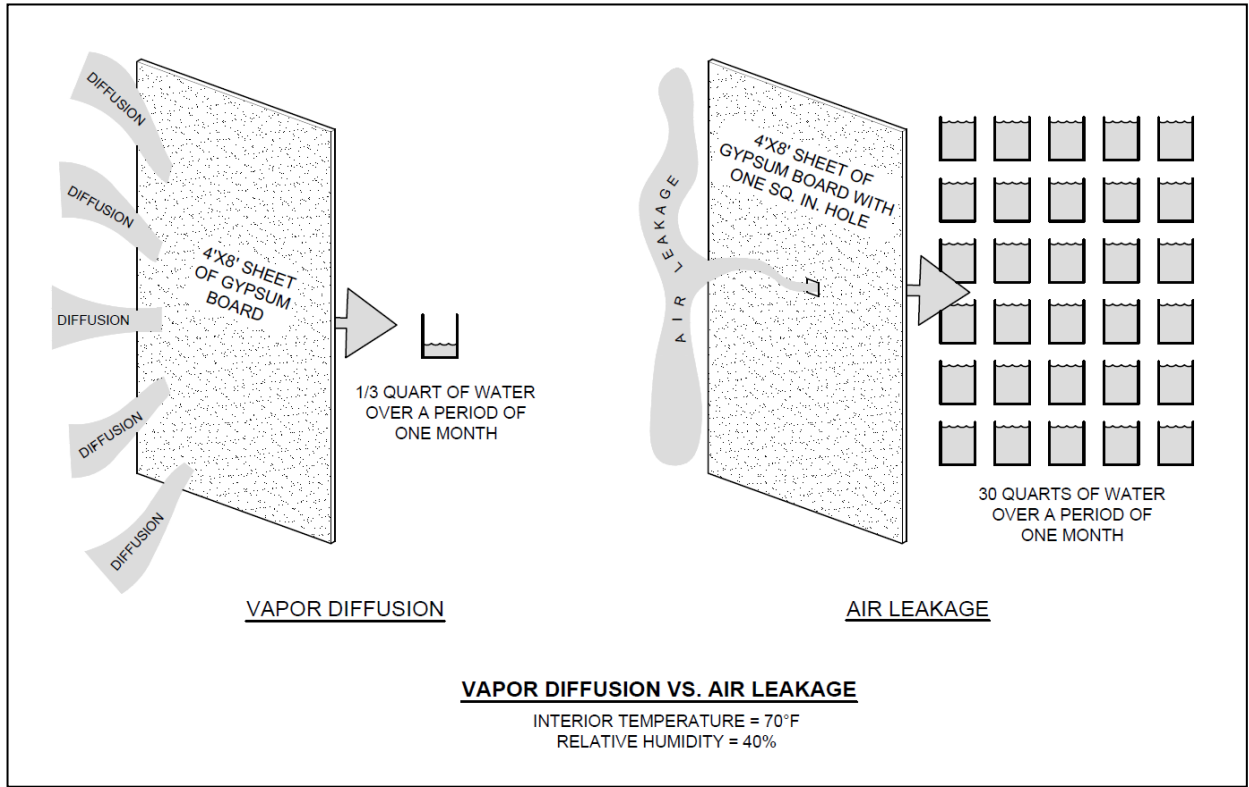

Figure 1: Air leakage vs. vapor diffusion
 (Source: Building Science Corporation)

Cold Storage Design Considerations

GAF does not practice architecture or engineering. This section is provided for guidance purposes only based on GAF's experience in the commercial roofing industry. However, there are many factors that may affect roof design, including specific job site conditions, local building codes, building use, etc., which must be taken into account. GAF recommends consultation with a design professional to determine specific roofing needs and requirements for each particular project.

Proper roofing system design and selection requires the consideration of many factors. Although GAF's expertise is in materials manufacturing, and not in engineering, architecture, or specialized roof consulting, GAF has decades of extensive experience in the practical aspects of roofing. Our experience suggests that careful consideration of the following will help provide a fundamentally sound basis for design and selection of EverGuard® single-ply roofing systems.

Basic Concepts of Cold Storage Design

GAF defines cold storage as a building or portion of a building or structure designed to promote extended shelf life of products or commodities and typically has year-round temperatures below 50° F (10° C). There are other terms used to describe cold storage and they are typically categorized by the range at which the interior temperature is held. Other terms for cold storage may include: coolers, chill coolers, refrigerated warehouses, freezers, or blast freezers.

A cold storage building should have an uninterrupted, continuous building envelope with these attributes:

- Adequate insulation to maintain interior temperature and minimize thermal loss
- Compensation for thermal expansion and contraction
- Control of air and water vapor movement

There are several ways to achieve these objectives. The following are commonly used methods in cold storage design:

- Exterior Envelope System Method
- Interior Envelope System Method
- Building-In-A-Building Method

Exterior Envelope System Method: This method entails a vapor retarder system located on the exterior side of the building’s structural system. The vapor retarder system “encapsulates” the building by being located on the outside of the exterior walls’ insulation layer, under the floor and over the roof’s insulation layer. See Figure 2 for a conceptual depiction of this method.

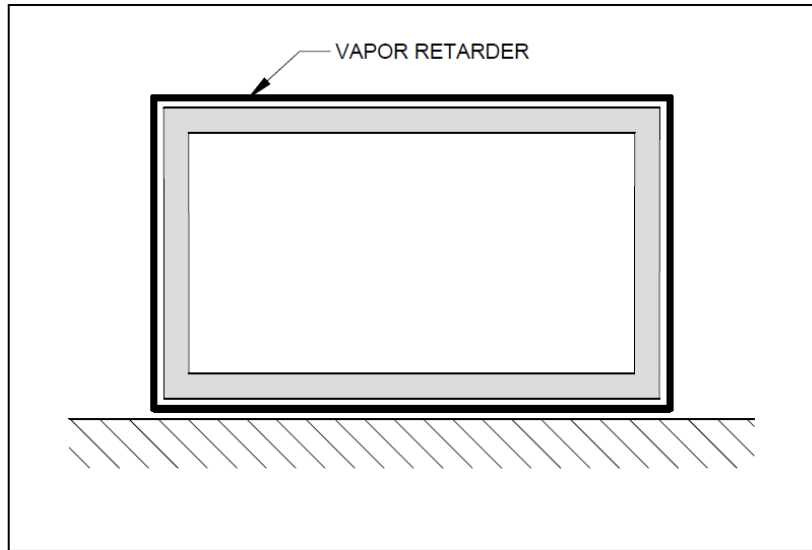

Figure 2: Conceptual Diagram of “Exterior Envelope System Method”

Interior Envelope System Method: This method entails a vapor retarder system located on the interior side of the structural system. In this scenario, the vapor retarder system is located under the roof deck, inside the exterior walls and above the floor. See Figure 3 for a conceptual depiction of this method.

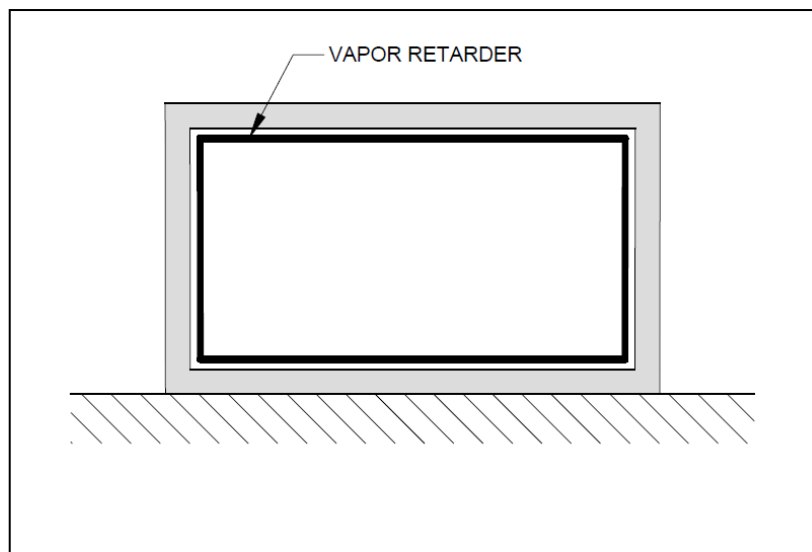

Figure 3: Conceptual Diagram of “Interior Envelope System Method”

Building-In-A-Building Method: This method entails constructing a cold storage structure within a building's enclosure, i.e., a building within a building. The insulation and vapor retarder system then may be applied to the outside of the inner structure's envelope. See Figure 4 for a conceptual depiction of this method.

With this solution, the outer building envelope structure provides a more constant temperature around the cold storage structure and eliminates exposure to the sun's heat. It should be noted that the roof system on the outer building is not to be considered a "roof over a cold storage building" because the interior space beneath it is normally conditioned.

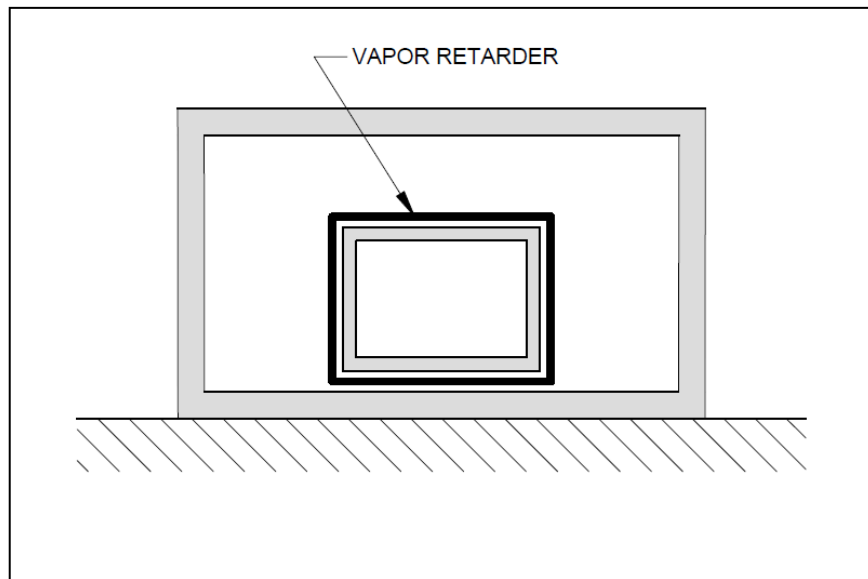

Figure 4: Conceptual Diagram of "Building-In-A-Building Method"

Design Considerations

The design and construction of cold storage buildings requires special attention to the following relevant design considerations:

- Building location
- Design values
- Roof insulation
- Thermal shorts/thermal bridging
- Expansion and contraction
- Temperature Pull Down
- Air leakage and water vapor movement
- Vapor retarder perm ratings

Building Location

The climate in which a cold storage building is located is a factor in determining where to install the vapor retarder.

In warm climates, the prevailing vapor drive direction is inward. Under these conditions, the most effective location for a vapor retarder is outside the insulation, i.e., the warm side of the insulation. In many cases, the roof membrane serves as the vapor retarder.

In moderate climates (e.g., Nashville and Kansas City), the vapor drive may be in either direction and the location of the vapor retarder/air barrier depends on a time-temperature pressure relationship. It is up to the designer to determine the appropriate location for a vapor retarder.

In cold climates, the vapor drive will be reversed when the outside temperature is colder than the interior temperature. Also, there is less concern with condensation issues, because with cooler temperatures, the amount of moisture is relatively small and vapor pressure differences may be insignificant. Again, it is up to the designer to determine the appropriate location for a vapor retarder.

Design Values

A designer may choose to perform a dew-point or hygrothermal analysis to confirm the design of a cold storage's envelope. Design values are needed for the following:

- Interior dry bulb temperature
- Interior relative humidity
- Exterior dry bulb temperature

Designers should keep in mind that the values used for design relative humidity and design interior temperature are theoretical constant values based upon design assumptions. These design values should be based upon conservative assumptions of probable conditions.

Roof Insulation

Insulation plays a critical role in the building envelope performance of a cold storage building. In order to minimize the potential for condensation, appropriate amounts of insulation should be used. Insulation type and R-value selection are affected by numerous factors, such as cost, desired energy efficiency, suitable material properties, interior design temperatures, and climatic conditions.

The following table offers suggestions for minimum R-values for roof insulation in cold storage buildings. These R-values are based on the "Energy Modeling Guideline for Cold Storage and Refrigerated Warehouse Facilities" issued by the International Association for Cold Storage Construction and the International Association of Refrigerated Warehouses. However, it is the designer's responsibility to determine the appropriate amount of roof insulation.

Suggested Minimum R-values for Roof Insulation*

Cold Storage Type	Interior Temperature Range °F (°C)	Minimum R-value for Roof Insulation
Coolers	40 to 50 (4.4 to 10)	30 to 35
Chill Coolers	25 to 35 (-3.8 to 1.6)	35 to 40
Holding Freezers	-10 to -20 (-23.3 to -28.9)	45 to 50
Blast Freezers	-40 to -50 (-40 to -45.5)	50 to 60

*2018 edition of the American Society of Heating, Refrigerating and Air-Conditioning Engineers' ASHRAE Handbook—Refrigeration

The type of insulation used should be suitable and compatible for use in a cold storage building. A commonly used insulation type is closed-cell foam insulation, such as GAF EnergyGuard™ polyiso insulation. Additionally, roof penetrations, such as mechanical curbs or roof hatches, should be appropriately insulated and sealed.

Cold storage buildings with insulated suspended ceilings may be problematic, because it is difficult to make the insulation—as well as the vapor retarder—uninterrupted and continuous. Attics with floor insulation may also be a concern for the same reason.

Thermal Shorts/Thermal Bridging

Designers should pay close attention to thermal shorts and thermal bridging when designing roofing systems over cold storage buildings.

To reduce the effects of thermal shorts, roof insulation should be installed in at least two layers with offset joints to minimize air leakage and movement.

To reduce the effects of thermal bridging, the roof membrane and upper layer(s) of rigid board insulation should be adhered. Mechanical fasteners as the securement method for a roof membrane or the upper layer(s) of rigid board insulation allows thermal bridging to occur and is less energy efficient.

When the substrate is a steel roof deck, the first layer of insulation (i.e., the layer in direct contact with the roof deck) may be mechanically attached. Subsequent layers should be installed with adhesives.

Expansion and Contraction

Accommodation should be made for thermal movement in cold storage buildings. Building movement may lead to tearing of or damage to a vapor retarder or a roofing system.

Pipes in roofs and walls may move due to thermal expansion and contraction, as well as vibration, so it is important to select pipe penetration flashings that can accommodate movement, such as pre-manufactured flashing boots.

Temperature Pull Down

The American Society of Heating, Refrigerating and Air-Conditioning Engineers (ASHRAE) offers the following temperature pull down considerations for cold storage buildings in the 2018 edition of the ASHRAE Handbook—Refrigeration, Chapter 24:

“Because of the low temperatures in freezer facilities, contraction of structural members in these spaces will be substantially greater than in any surrounding ambient or cooler facilities. Therefore, contraction joints must be properly designed to prevent structural damage during facility pulldown.

The first stage of temperature reduction should be from ambient down to 35°F at whatever rate of reduction the refrigeration system can achieve.

The room should then be held at that temperature until it is dry. Finishes are especially subject to damage when temperatures are lowered too rapidly. Portland cement plaster should be fully cured before the room is refrigerated.

If there is a possibility that the room is airtight (most likely for small rooms, 20 by 20 ft maximum), swinging doors should be partially open during pulldown to relieve the internal vacuum caused by the cooling of the air, or vents should be provided. Permanent air relief vents are needed for continual operation of defrosts in small rooms with only swinging doors. Both conditions of possible air heating during defrost and cooling should be considered in design of air vents and reliefs.

The concrete slab will contract during pulldown, causing slab/ wall joints, contraction joints, and other construction joints to open. At the end of the holding period (i.e., at 35°F), any necessary caulking should be done.

An average time for drying is 72 h. However, indicators that may be used include watching the rate of frost formation on the coils or measuring the rate of moisture removal by capturing the condensation during defrost.

After the refrigerated room is dry, the temperature can then be reduced again at whatever rate the refrigeration equipment can achieve until the operating temperature is reached. Rates of 10°F per day have been used in the past, but if care has been taken to remove all the construction moisture in the previous steps, faster rates are possible without damage.”

Air Leakage and Water Vapor Movement

Problems occur when there are paths for air and water vapor movement within the building envelope. It is imperative that the vapor retarder and roof system be continuous, tied to the wall air barrier, and completely sealed at:

- Laps and seams
- Roof penetrations, i.e., pipes, structural members, mechanical curbs, roof hatches, etc.
- Roof-to-wall interface/intersections

It is also advisable to limit the number of penetrations through the roof assembly.

If the roof membrane is not serving as the vapor retarder, avoid attaching the roof system through the vapor retarder with mechanical fasteners.

Special attention should be paid to steel roof decks which are used in many cold storage buildings. It is challenging to seal steel roof decks at walls and penetrations. Also, deck flutes can serve as “conduits” or pathways through which air and air-transported moisture flow. To minimize these effects, flutes may be filled with closed-cell spray polyurethane foam at walls and penetration locations.

Vapor Retarder Perm Ratings

Vapor retarders are typically membranes with relatively low permeance values, but not all vapor retarders are equal. There are three classes of vapor retarder materials, as shown in Figure 5.

Class	Definition
I	0.1 perm or less
II	Greater than 0.1 perm to less than 1.0 perm
III	Greater than 1.0 perm to less than 10 perm

Figure 5: Three classes of vapor retarders

Most roof membranes are Class I vapor retarders. Perm ratings for single-ply membranes range from 0.03 to 0.06 perms. An example of a Class II vapor retarder is asphalt felts, which have perm ratings ranging from 0.3 to 0.8 perms. Examples of Class III vapor retarders are latex or acrylic paint.

GAF recommends that Class I vapor retarders be used on cold storage buildings.

It is important to note that these are material ratings; the full system needs to be designed and installed correctly for proper functionality.

Application Guidelines for Roof Systems on Cold Storage Buildings



If a single-ply roof system is used as a vapor retarder for a cold storage building, GAF recommends an adhered attachment method to minimize thermal bridging and to maximize the energy efficiency of the installed roof. Refer to the EverGuard® TPO/PVC Adhered Roofing System Overview & General Requirements Manual for design considerations and application guidelines. This guide supplements that manual.

However, experience has shown mechanically attached and Drill-Tec™ RhinoBond® attached roofing systems have been successful when used with cold storage buildings where the membrane serves as the air barrier system. Refer to the EverGuard® TPO/PVC Mechanically Attached Roofing System Overview & General Requirements Manual and Drill-Tec™ RhinoBond® Attachment System Overview & General Requirements Manual for design considerations and application guidelines. This guide supplements those manuals.

Below are additional guidelines for projects involving roof systems over cold storage buildings:

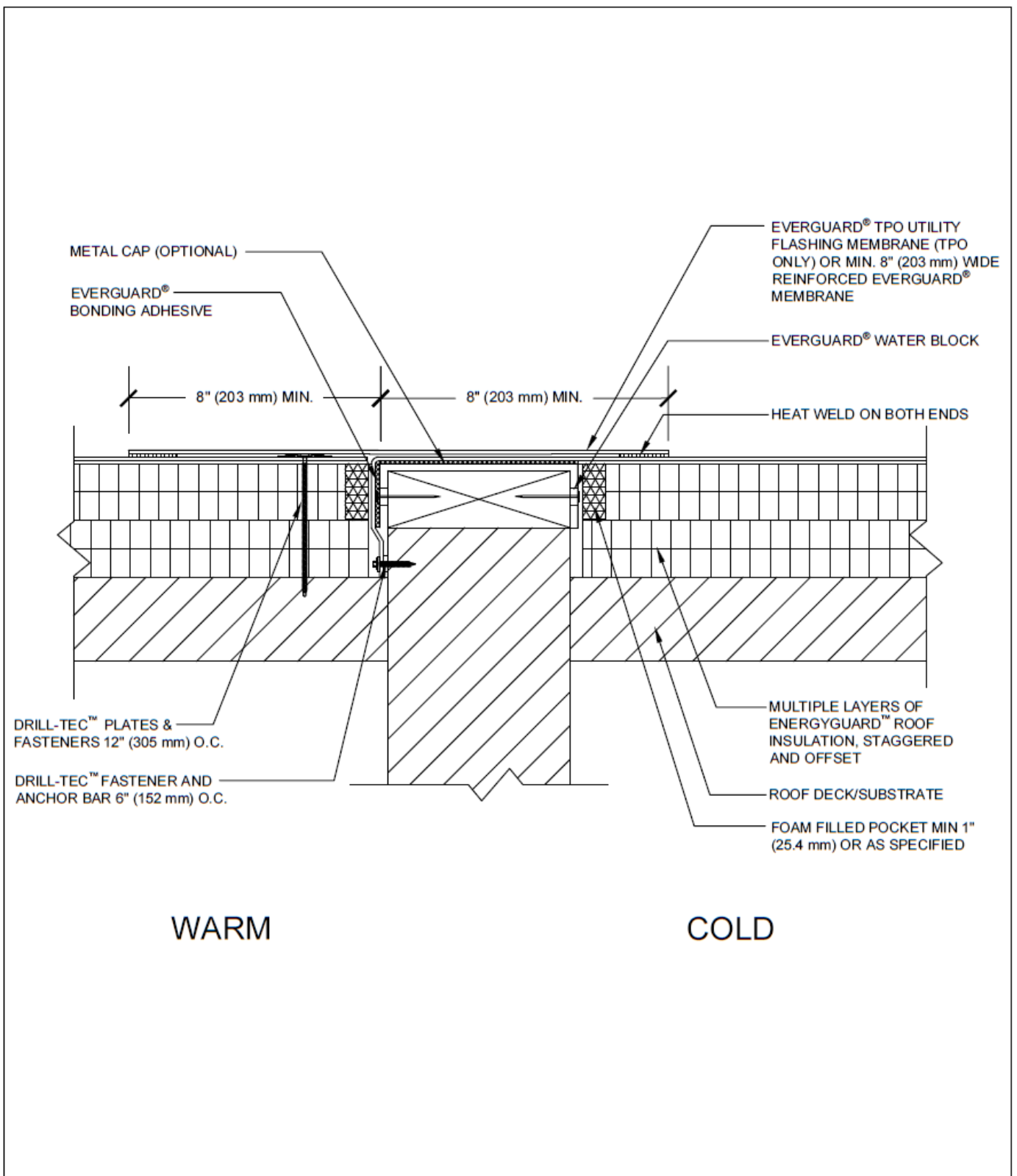
- 1) For adhered attachment systems:
 - a) It is highly recommended that the first layer of insulation is mechanically attached over steel decks and subsequent layers of insulation are secured with adhesive to prevent the thermal bridging of the fasteners.
 - b) Insulation boards installed in multiple layers must have the joints between boards staggered in all directions a minimum of 6" (152 mm) between layers. Maximum board size is 4'x4' (1.22 m x 1.22 m) when adhering the top layer.
- 2) For mechanically attached and Drill-Tec™ RhinoBond® attachment systems, install insulation boards with long joints and end joints in a continuous straight line in order to create a grid fastening pattern. Multiple layers of insulation are to be staggered.
- 3) The top layer of insulation boards shall be held back from all penetrations a minimum of 1" (25.4 mm) for the addition of closed-cell spray polyurethane foam to fill this gap. This includes parapet walls, expansion joints, curbs, pipes, roof drains, etc. This can easily be accomplished by standing a 2x wood lumber on its side (on all straight runs) when the insulation is installed and then pulling out the wood to install the foam to the height of the insulation.
- 4) Prior to installing perimeter edge metal, the gap at the insulation to wood nailer interface should be filled in with closed-cell spray polyurethane foam. This gap should be filled to the height of the insulation and wood nailer.





 <p>www.gaf.com 1 Campus Drive, Parsippany, NJ 07054</p>	 <p>FIELD OF ROOF SERIES</p>	<p>DRAWING #</p> <p>130</p>	<p>COLD TO WARM TRANSITION DETAIL</p>	<p>THIS DETAIL APPLIES TO:</p> <p>Adhered Systems Mechanically Attached Systems RhinoBond® Systems</p>
	<p>COLD STORAGE DETAILS</p>	<p>SCALE</p> <p>N.T.S.</p>		<p>REVISION DATE</p> <p>6-1-20</p>

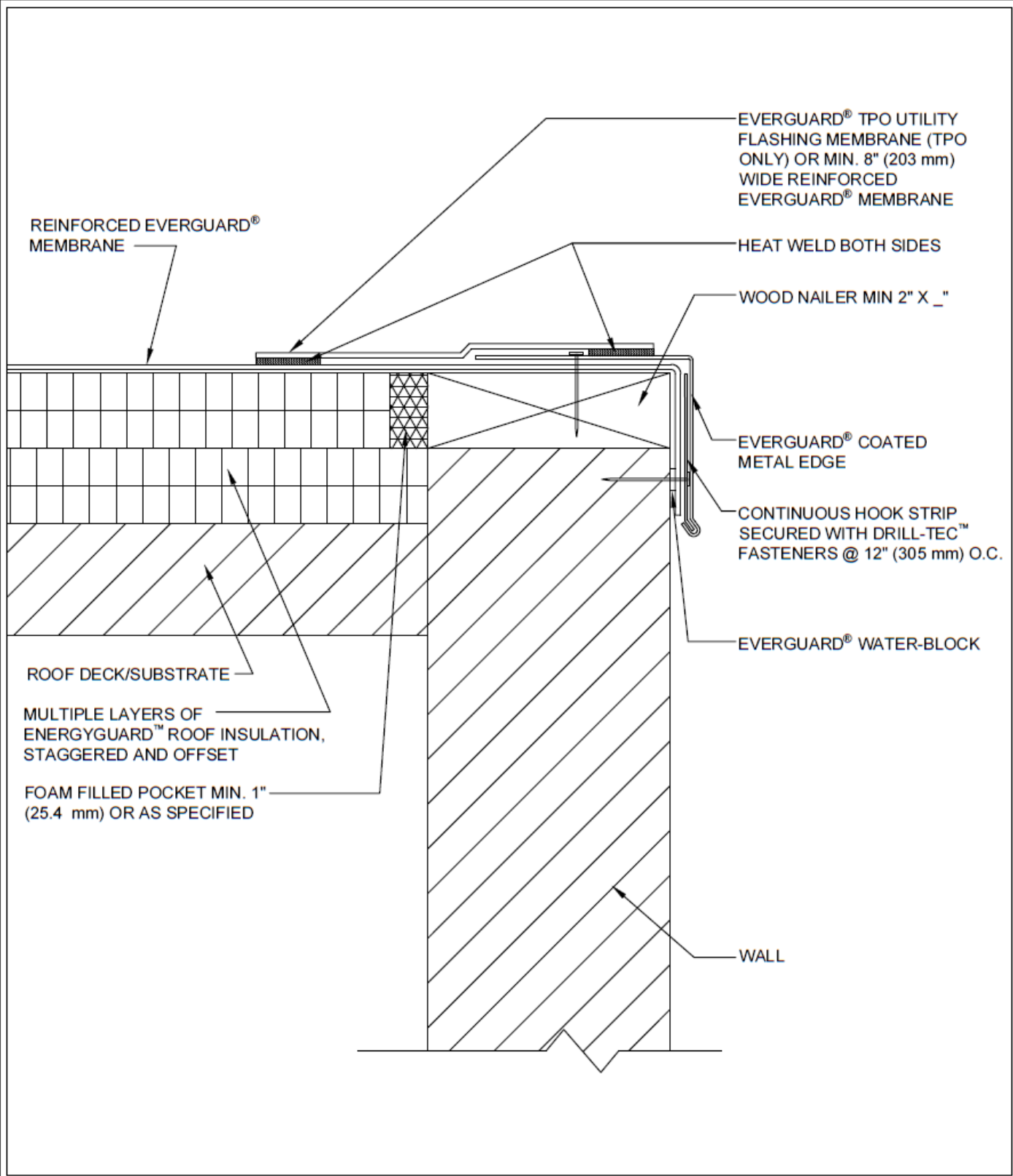

Published 6/2020

Cold Storage Guide

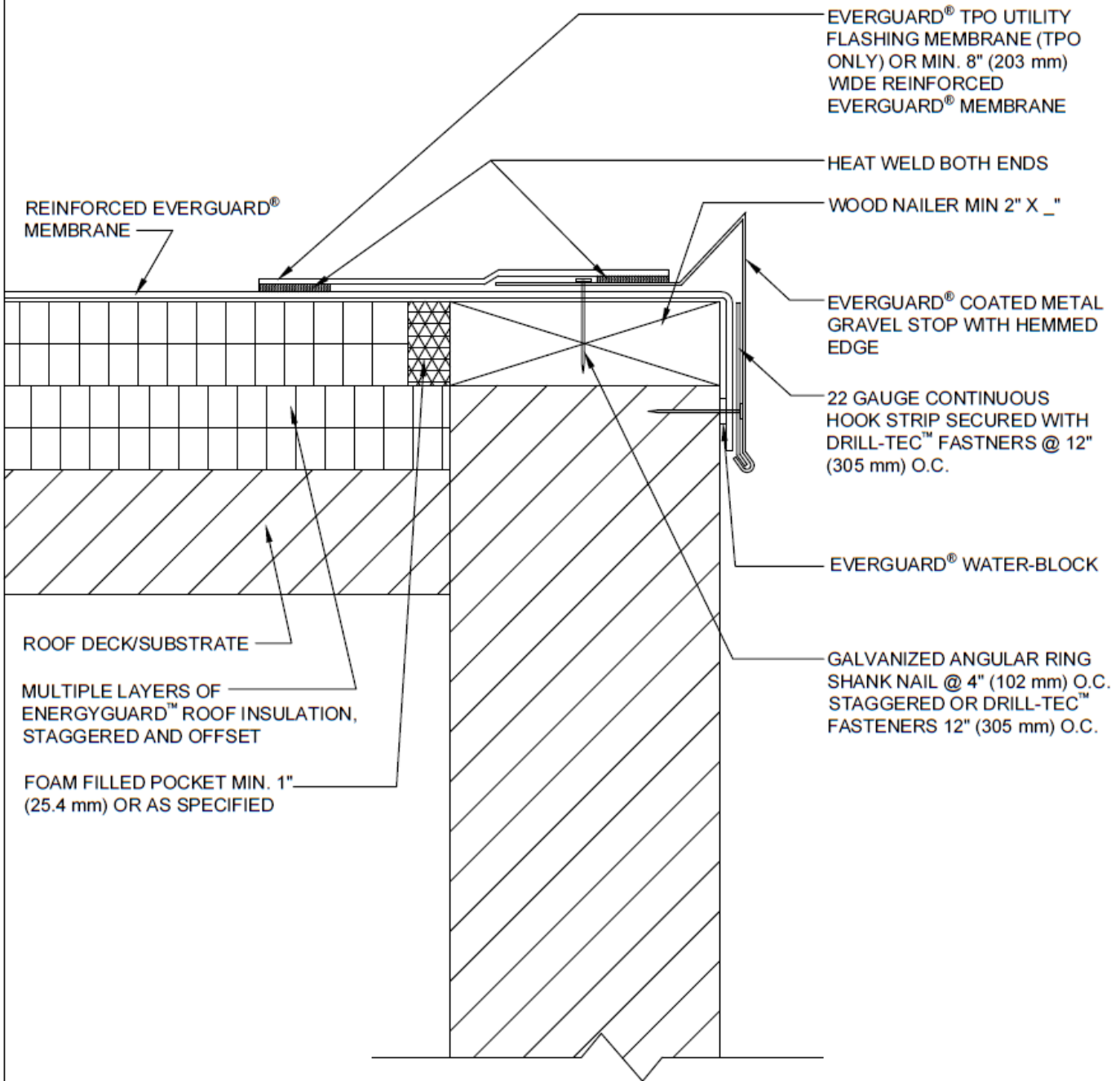

 www.gaf.com 1 Campus Drive, Parsippany, NJ 07054	 SINGLE-PLY ROOFING SYSTEMS ROOF EDGE SERIES	DRAWING #	COATED METAL ROOF EDGE DETAIL	THIS DETAIL APPLIES TO: Adhered Systems Mechanically Attached Systems RhinoBond® Systems
		201		
COLD STORAGE DETAILS		SCALE	6-1-20	
		N.T.S.		



 www.gaf.com 1 Campus Drive, Parsippany, NJ 07054	 ROOF EDGE SERIES	DRAWING#	GRAVEL STOP COATED METAL ROOF EDGE DETAIL	THIS DETAIL APPLIES TO:
		202B		Adhered Systems Mechanically Attached Systems RhinoBond® Systems
COLD STORAGE DETAILS		SCALE		REVISION DATE
		N.T.S.		6-1-20

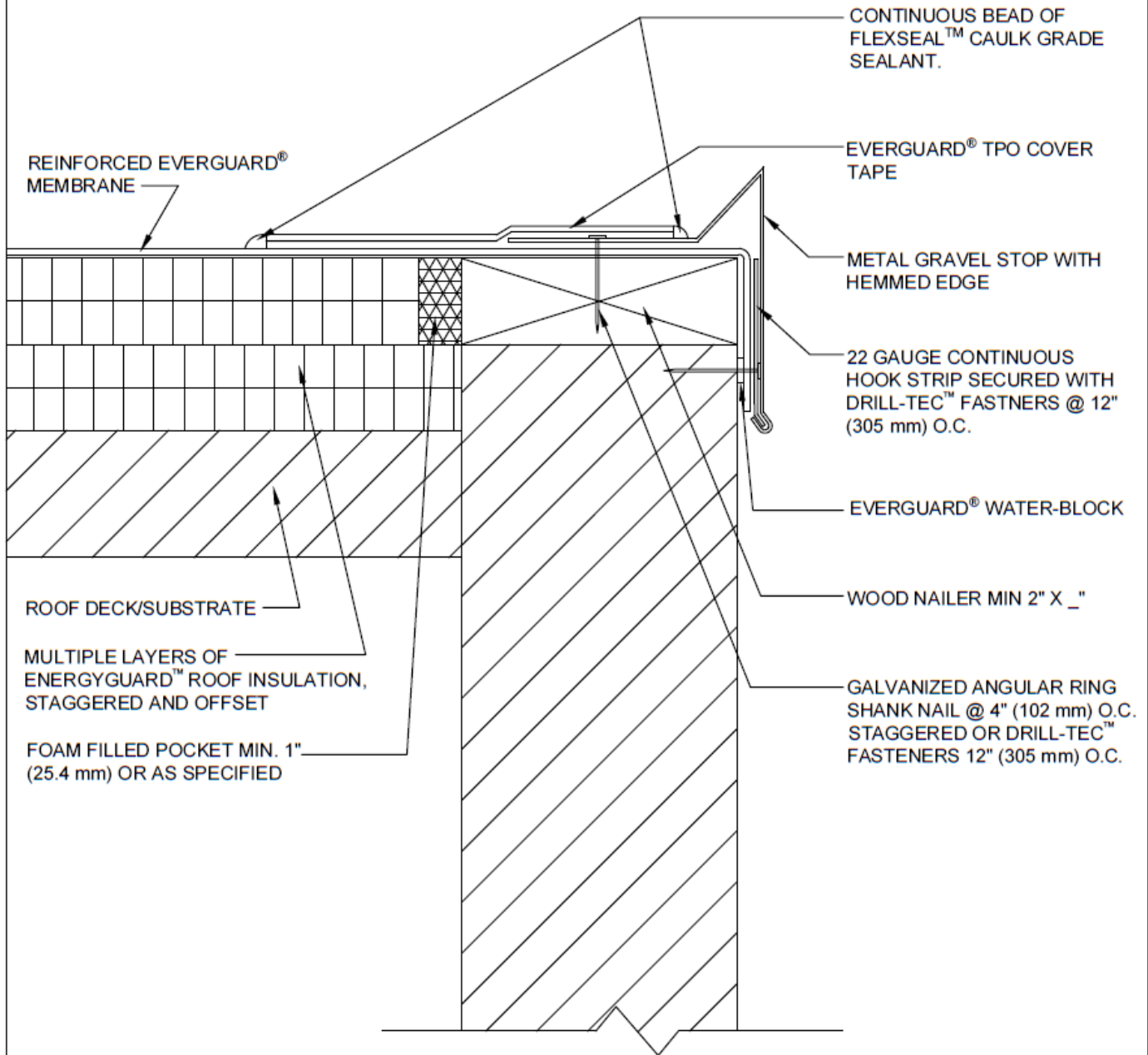

Published 6/2020

Cold Storage Guide



NOTE:

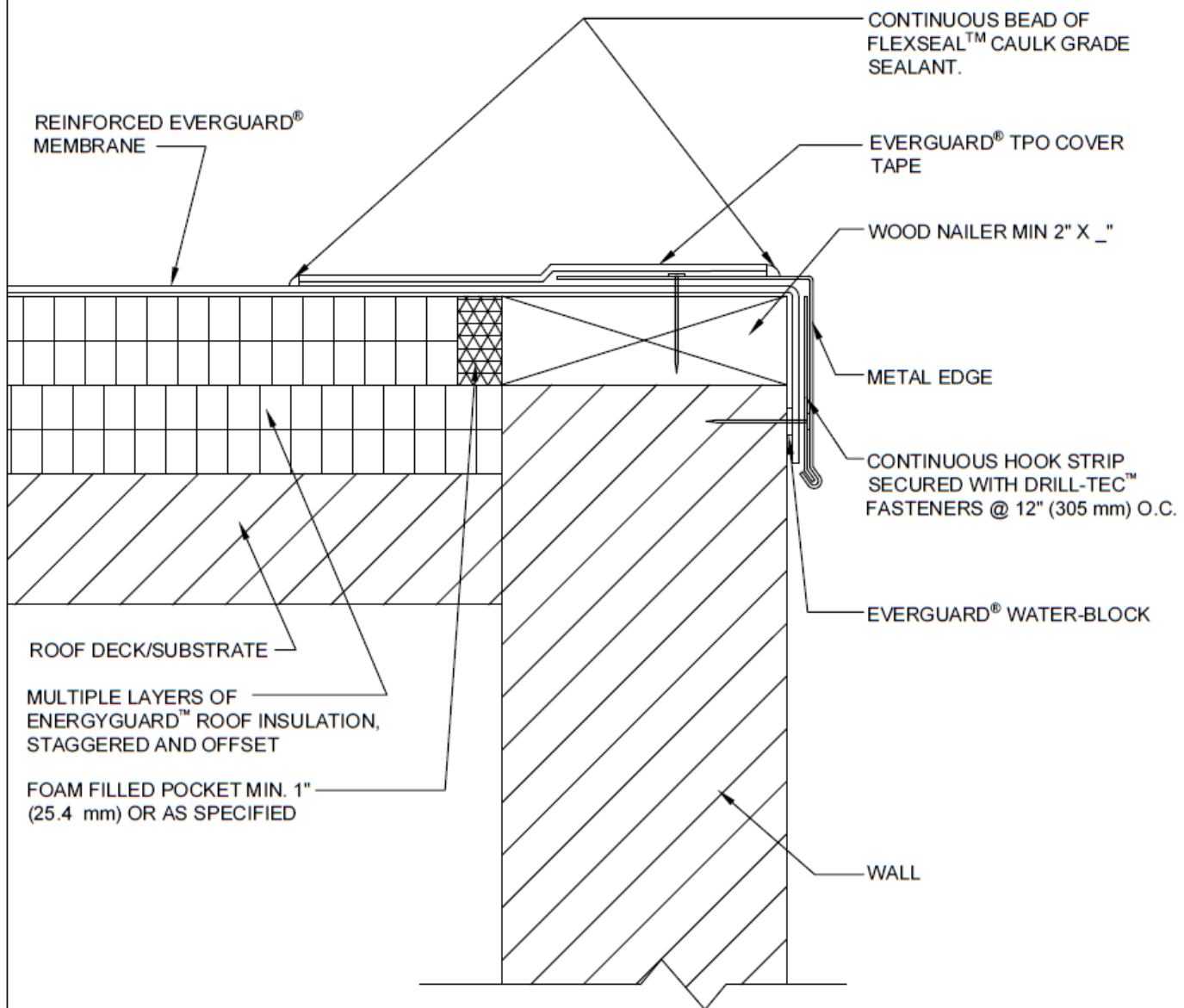

1. CLEAN METAL AND MEMBRANE WITH EVERGUARD® TPO SEAM CLEANER AND ALLOW TO DRY. ONCE DRY, PRIME METAL AND MEMBRANE WITH EVERGUARD® TPO PRIMER BEFORE INSTALLING EVERGUARD® TPO COVER TAPE.

 www.gaf.com 1 Campus Drive, Parsippany, NJ 07054	 ROOF EDGE SERIES	DRAWING# 202C	GRAVEL STOP METAL ROOF EDGE WITH COVER TAPE DETAIL	THIS DETAIL APPLIES TO: Adhered Systems Mechanically Attached Systems RhinoBond® Systems
	COLD STORAGE DETAILS	SCALE N.T.S.		REVISION DATE 6-1-20



NOTE:



1. CLEAN METAL AND MEMBRANE WITH EVERGUARD® TPO SEAM CLEANER AND ALLOW TO DRY. ONCE DRY, PRIME METAL AND MEMBRANE WITH EVERGUARD® TPO PRIMER BEFORE INSTALLING EVERGUARD® TPO COVER TAPE.

 www.gaf.com 1 Campus Drive, Parsippany, NJ 07054	 ROOF EDGE SERIES	DRAWING # 203C	METAL ROOF EDGE WITH COVER TAPE DETAIL	THIS DETAIL APPLIES TO: Adhered Systems Mechanically Attached Systems RhinoBond® Systems
	COLD STORAGE DETAILS	SCALE N.T.S.		REVISION DATE 6-1-20

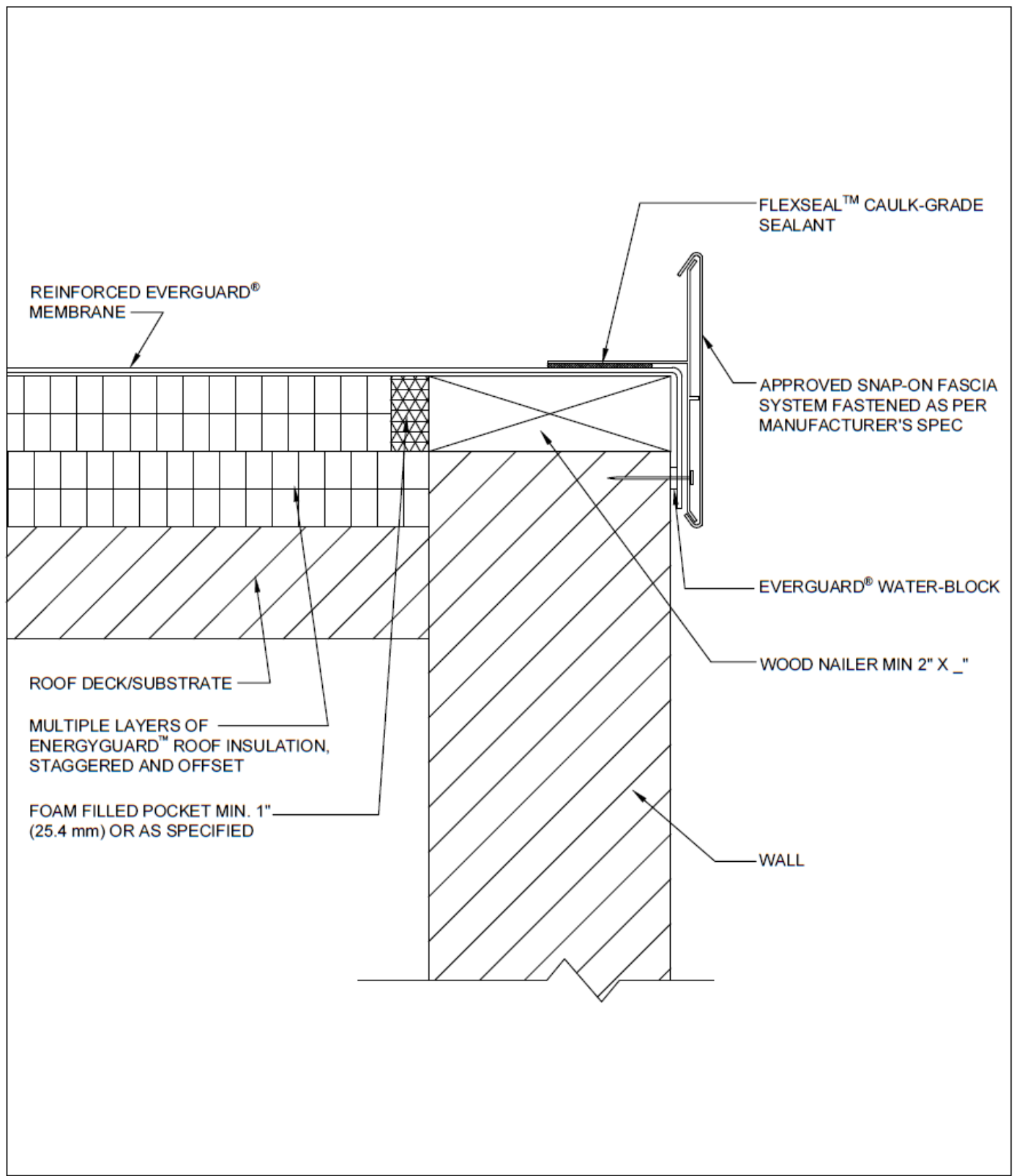

Published 6/2020

Cold Storage Guide

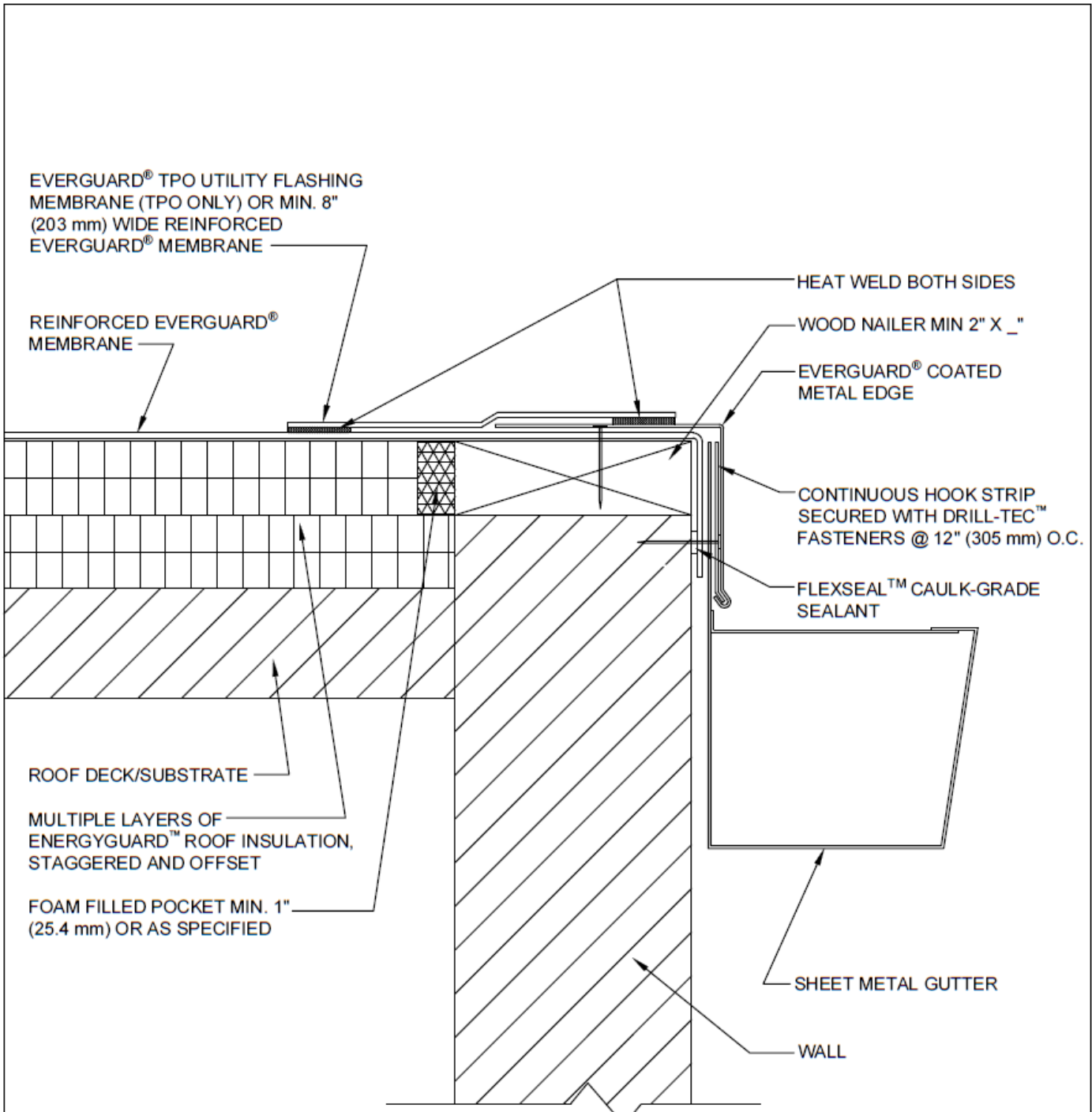

 www.gaf.com 1 Campus Drive, Parsippany, NJ 07054	 ROOF EDGE SERIES	DRAWING# 205B	SNAP ON FASCIA DETAIL	THIS DETAIL APPLIES TO: Adhered Systems Mechanically Attached Systems RhinoBond® Systems
	COLD STORAGE DETAILS	SCALE N.T.S.		REVISION DATE 6-1-20



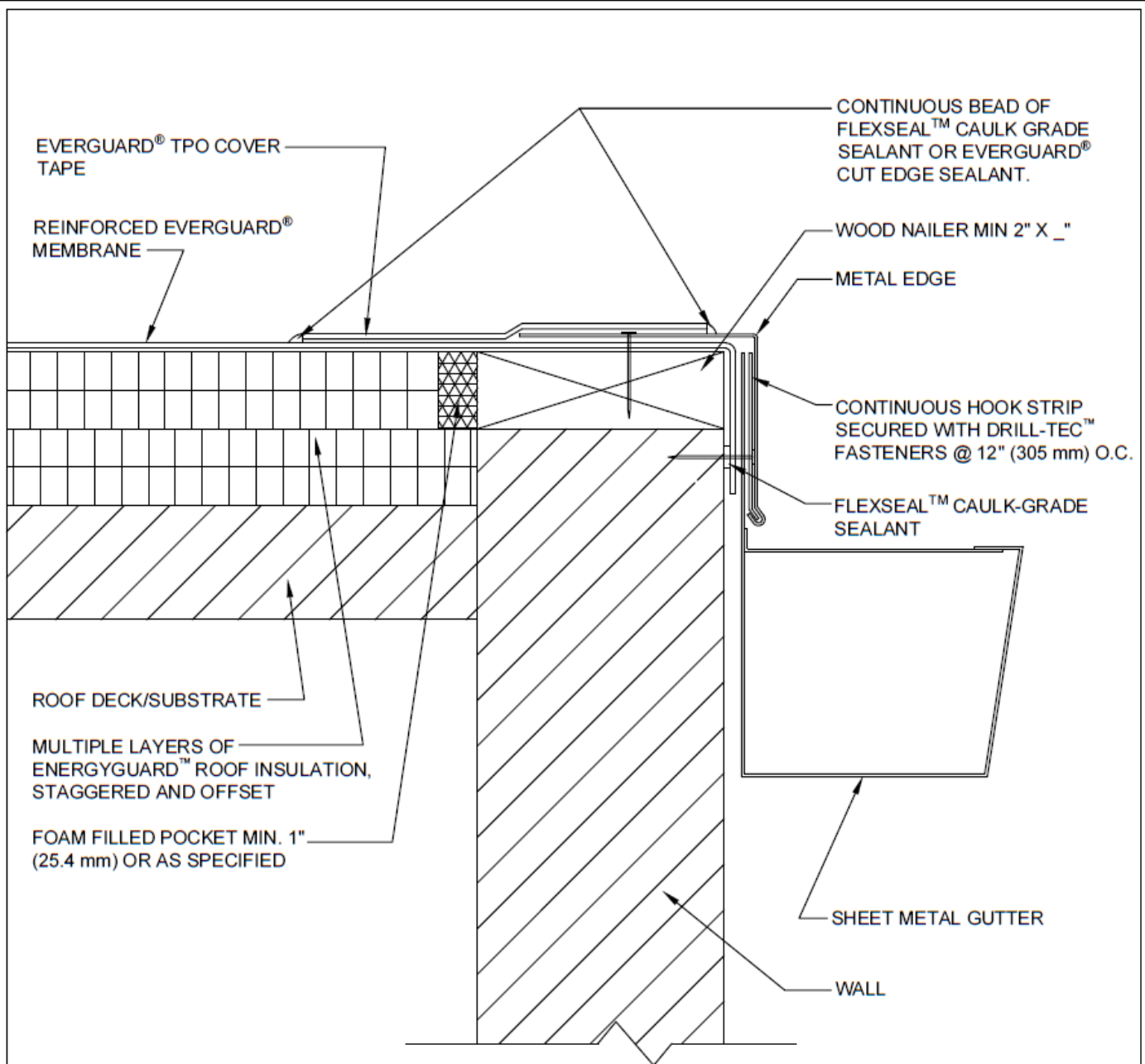

 <small>www.gaf.com 1 Campus Drive Parsippany, NJ 07054</small>	 ROOF EDGE SERIES	DRAWING #	GUTTER WITH COATED METAL ROOF EDGE	THIS DETAIL APPLIES TO:
		211B		Adhered Systems Mechanically Attached Systems RhinoBond® Systems
COLD STORAGE DETAILS		SCALE		REVISION DATE
		N.T.S.		6-1-20

Published 6/2020
Cold Storage Guide



NOTE:

1. CLEAN METAL AND MEMBRANE WITH EVERGUARD® TPO SEAM CLEANER AND ALLOW TO DRY. ONCE DRY, PRIME METAL AND MEMBRANE WITH EVERGUARD® TPO PRIMER BEFORE INSTALLING EVERGUARD® TPO COVER TAPE.

 www.gaf.com 1 Campus Drive, Parsippany, NJ 07054	 ROOF EDGE SERIES	DRAWING# 211C	GUTTER WITH METAL ROOF EDGE AND COVER TAPE DETAIL	THIS DETAIL APPLIES TO: Adhered Systems Mechanically Attached Systems RhinoBond® Systems
	COLD STORAGE DETAILS	SCALE N.T.S.		REVISION DATE 6-1-20

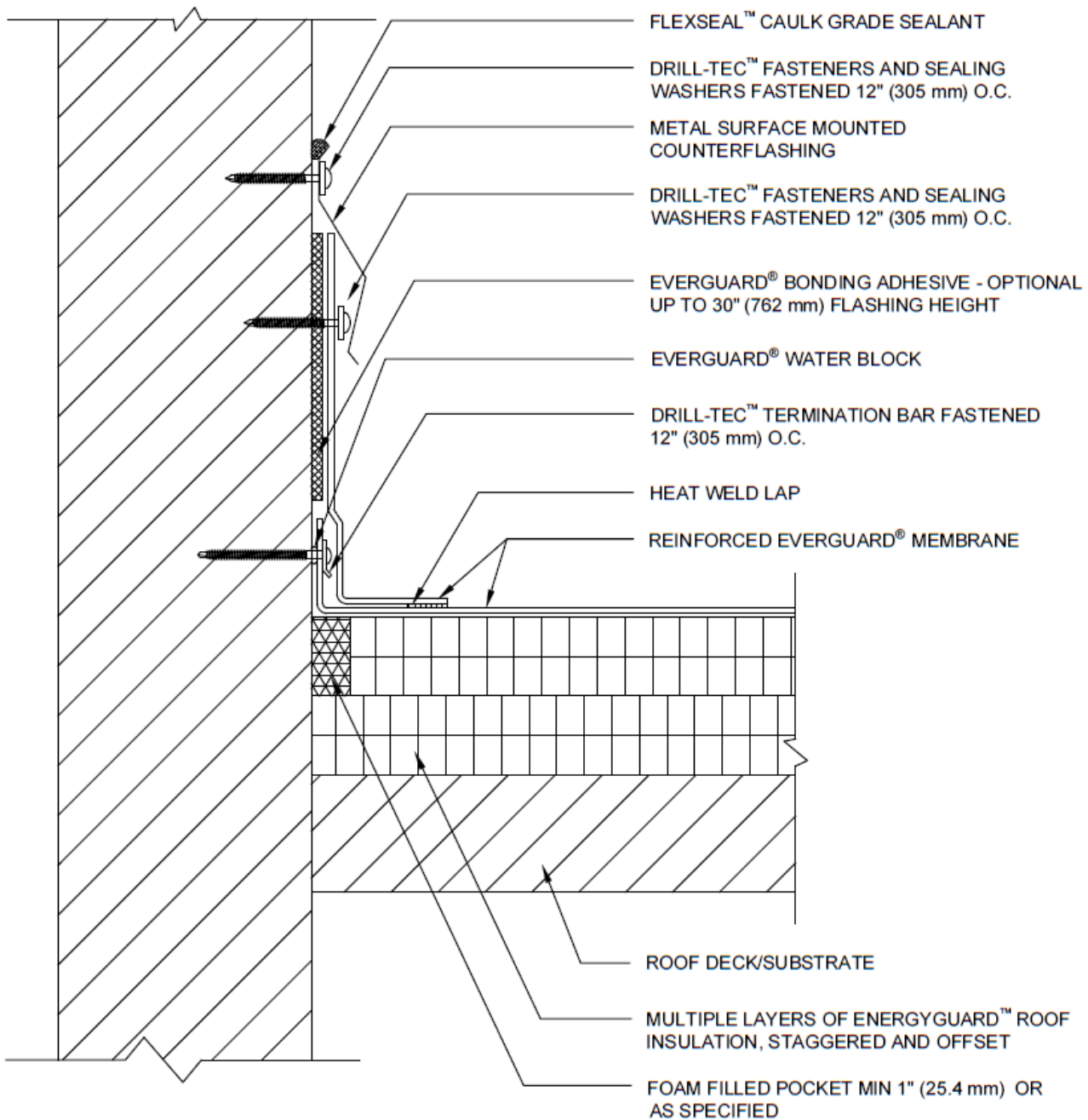

EverGuard
SINGLE-PLY ROOFING SYSTEMS
PARAPET WALL &
CURB SERIES
COLD STORAGE
DETAILS

DRAWING #
301B
SCALE
N.T.S.

WALL FLASHING WITH COUNTERFLASHING DETAIL

THIS DETAIL APPLIES TO:
Adhered Systems
Mechanically Attached Systems
RhinoBond® Systems

REVISION DATE
6-1-20

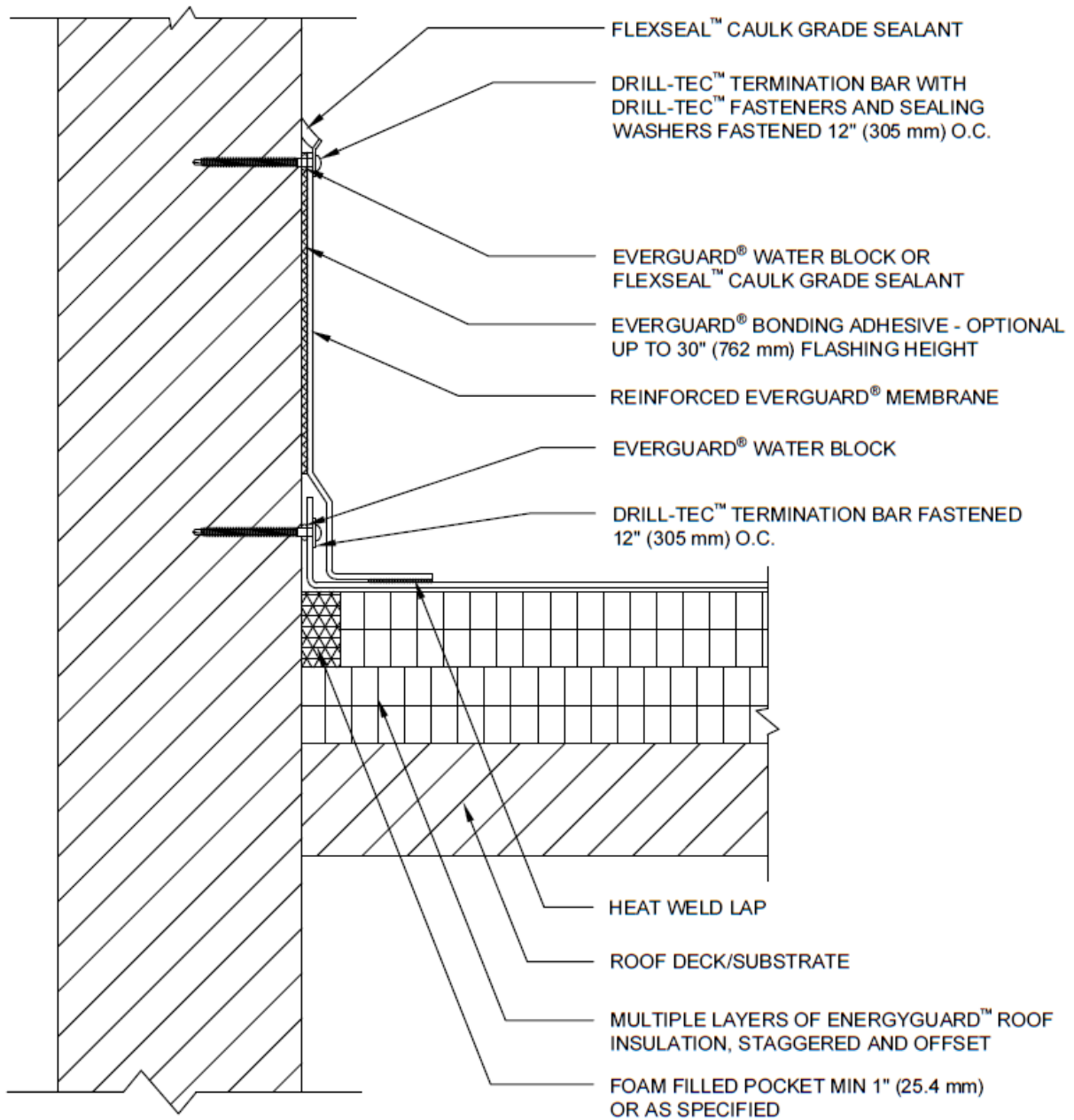

EverGuard
MULTI-PLY ROOFING SYSTEMS
PARAPET WALL &
CURB SERIES

COLD STORAGE
DETAILS

DRAWING #

302B

SCALE
N.T.S.

WALL/CURB FLASHING WITH TERMINATION BAR DETAIL

THIS DETAIL APPLIES TO:
Adhered Systems
Mechanically Attached Systems
RhinoBond® Systems

REVISION DATE
6-1-20

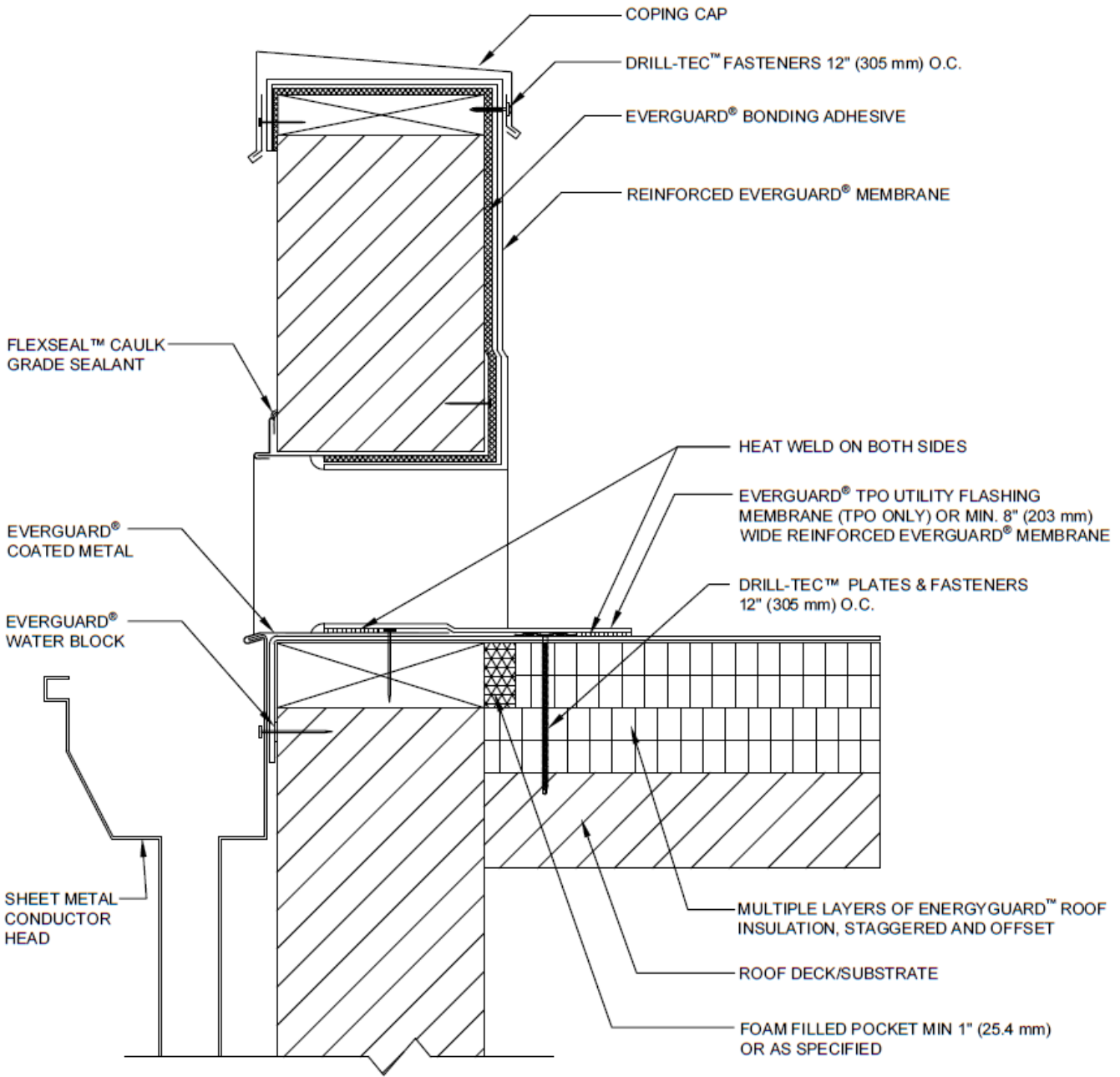

Published 6/2020

Cold Storage Guide



PARAPET WALL & CURB SERIES

COLD STORAGE DETAILS

DRAWING #

324B

SCALE
N.T.S.

THROUGH WALL SCUPPER WITH COATED METAL

THIS DETAIL APPLIES TO:
Adhered Systems
Mechanically Attached Systems
RhinoBond® Systems

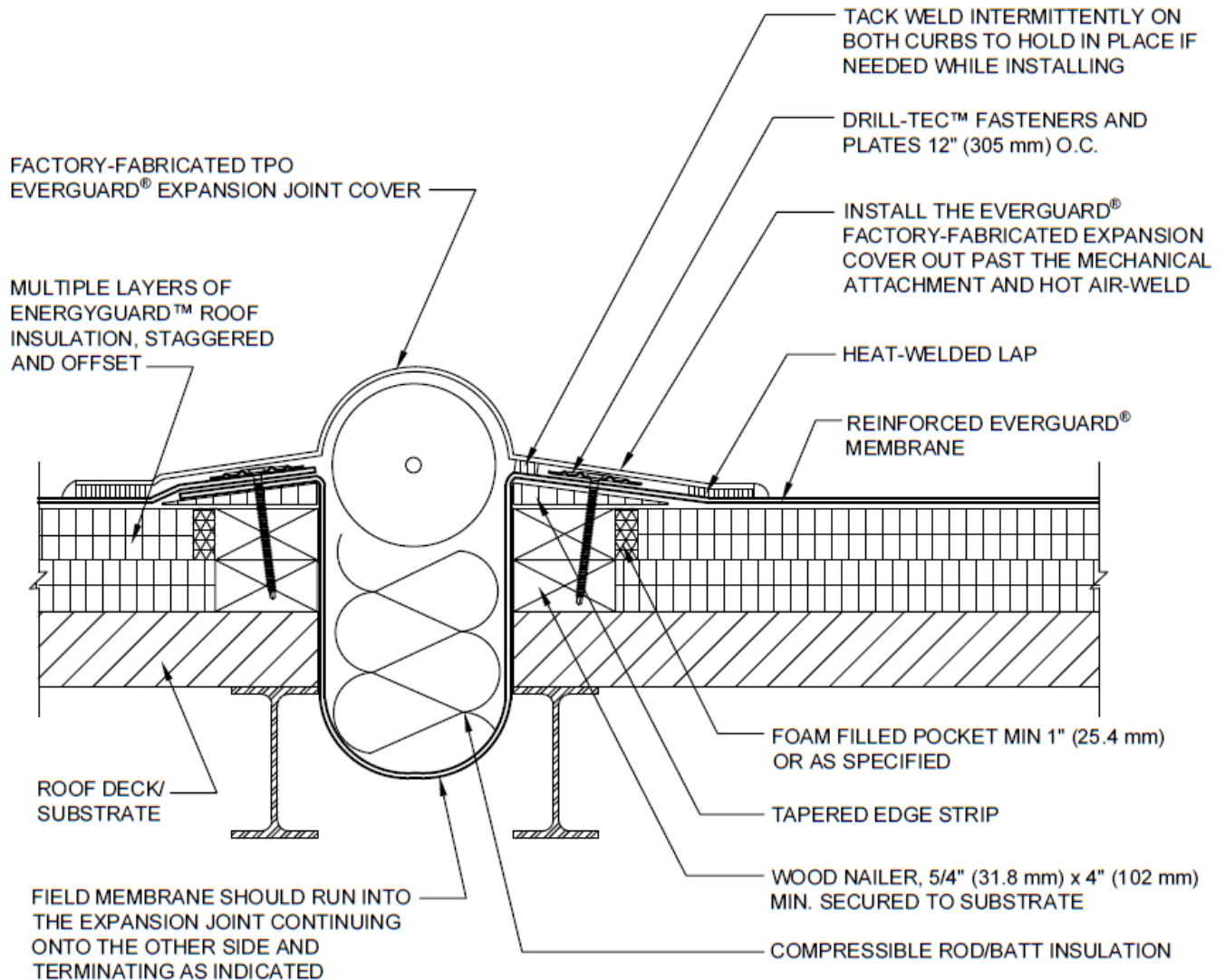

REVISION DATE
6-1-20



FIELD MEMBRANE SHOULD RUN INTO THE EXPANSION JOINT CONTINUING ONTO THE OTHER SIDE AND TERMINATING AS INDICATED

NOTE:

1. SEE EVERGUARD® DETAIL 330 FOR LAP APPLICATION.

 www.gaf.com 1 Campus Drive, Parsippany, NJ 07054	 EXPANSION JOINT SERIES	DRAWING # 401D	FACTORY FABRICATED EXPANSION JOINT DETAIL - FLAT TYPE	THIS DETAIL APPLIES TO: Adhered Systems Mechanically Attached Systems RhinoBond® Systems
	COLD STORAGE DETAILS	SCALE N.T.S.	TPO ONLY	

ALTERNATE INSTALLATION
[12" (305 mm) OR MORE OF INSULATION]

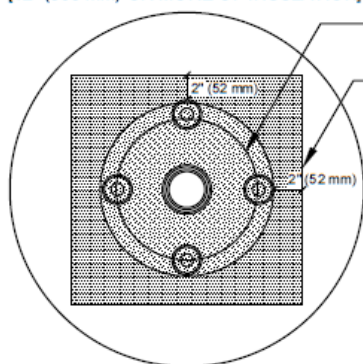

SEE NOTE #3

EVERGUARD® PREMOLDED VENT BOOT

TARGET MADE FROM
EVERGUARD® MEMBRANE

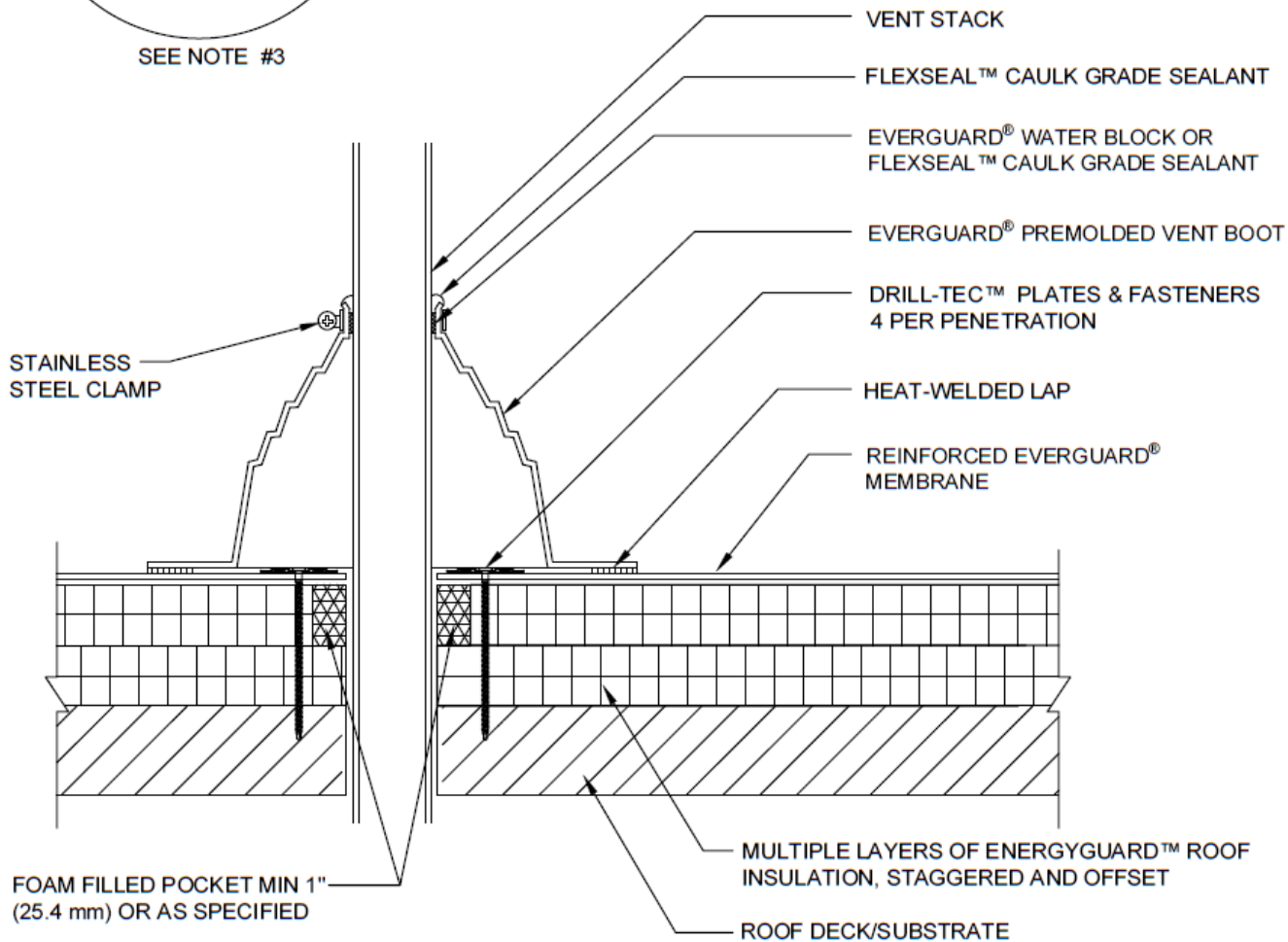

FOAM FILLED POCKET MIN 1"
(25.4 mm) OR AS SPECIFIED

NOTE:

1. DO NOT CUT SIDE OF PREMOLDED BOOT. IT MUST BE PULLED OVER VENT PIPE.
2. IF THE PLATES AND FASTENERS INTRUDE INTO BOOT FLANGE AREA, THEN A TARGET MUST FIRST BE INSTALLED OVER PLATES AND FASTENERS BEFORE BOOT INSTALLATION.



EverGuard
SINGLE-PLY ROOFING SYSTEMS
ROOF PENETRATION
SERIES

DRAWING #
506B

**PREMOLDED VENT BOOT
FLASHING DETAIL**

THIS DETAIL APPLIES TO:
Adhered Systems
Mechanically Attached Systems
RhinoBond® Systems

www.gaf.com
1 Campus Drive,
Parsippany, NJ 07054

COLD STORAGE
DETAILS

SCALE
N.T.S.

REVISION DATE
6-1-20

Published 6/2020

Cold Storage Guide