

# Perimeter Edge Metal



## Description:

EverGuard® PVC Drip Edge and EverGuard® TPO Drip Edge are specifically designed to simplify the installation process by using an EverGuard®-coated metal cover that you can weld membrane directly to, making installation easier and faster. This ensures compatibility with roof membrane, creates quick-to-ship convenience, and allows for economical pricing—helping you simplify projects and work efficiently.

- Sizes range from 2.5" (64 mm) – 10" (254 mm) face heights to accommodate multiple nailers and wall requirements.
- Covers are manufactured in 24 ga. galvanized steel.
- Factory-fabricated miters provide a cleaner, more aesthetically pleasing appearance. This eliminates the need for field fabrication, providing time and labor savings.

## Features and Benefits:

- The concealed splice-plate design helps prevent water migration under the cover and provides proper spacing for thermal movement of the fascia material.

## Codes/Testing Compliance:

- Evaluated in accordance with ANSI/SPRI ES-1, which is a requirement of IBC Section 1504.5 for roof system metal edge securement.

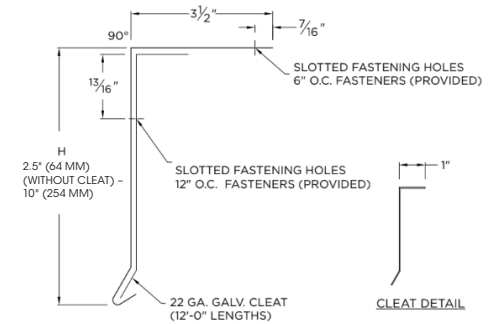

## Product Specifications

<b>STANDARD SIZES</b>	2.5" (64 mm) - 10" (254 mm)
<b>LENGTH</b>	12' (3.65 m)
<b>MATERIALS</b>	24 ga. galvanized steel with PVC or TPO coating
<b>FINISHES</b>	White, Gray, Tan
<b>PRE-PUNCHED HOLES</b>	Cleat: 12" (305 mm) o.c. Cover: 6" (152 mm) o.c.



Visit [gaf.com/PerimeterEdgeMetal](https://gaf.com/PerimeterEdgeMetal)

We protect what matters most™

