

EverGuard® TPO and EverGuard Extreme® TPO



Heat-Weldable Cover Tape

Description:

Increase efficiency when covering metal edges with factory-built EverGuard® and EverGuard Extreme® TPO Heat-Weldable Cover Tape. This single-ply roofing system accessory provides roofing contractors with an effective, easy-to-install component. GAF manufactures these and other accessories from its proven, durable EverGuard® and EverGuard Extreme® TPO single-ply reinforced membrane. GAF TPO accessories can help you reduce installation costs, risk of leaks, and callbacks, while helping you create a uniform look.

Application:

Clean and prime metal with EverGuard® TPO Primer. Allow primer to dry or flash off. Apply the self-adhering side to the metal and the heat-weldable side to the roofing membrane. See published application and specifications manual for detailed instructions.

Product Information:

EverGuard® and EverGuard Extreme® TPO Heat-Weldable Cover Tape is constructed from EverGuard® or EverGuard Extreme® reinforced 45-mil membrane. One package contains two 100' long, 6" wide rolls with a 3" self-adhered area and a 3" heat-weldable area.

Specifications	TPO Heat-Weldable Cover Tape	
Roll length	100'	
Roll width	6"	
Shipping Specifications		
Rolls per box	2	
Weight per box	34 lb. / 15.42 kg	
Boxes per pallet	27	
Product SKUs	EverGuard® TPO	EverGuard Extreme® TPO
	85P8920	85P8776

Code Approvals		
■ UL Listed Accessory	■ Texas Department of Insurance	
■ State of Florida Approved*	■ Miami-Dade County Approved*	
■ ICC-ES		

*EverGuard® TPO only

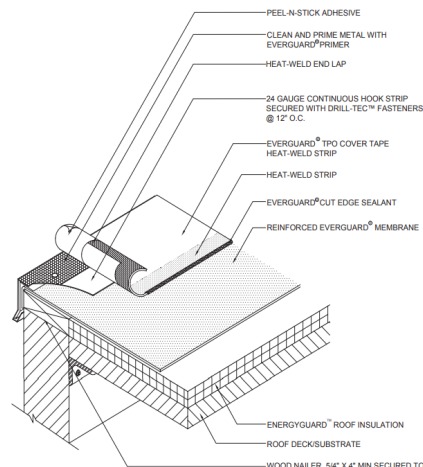

NOTE
 1. TPO COVER TAPE ONLY TO BE USED WITH TPO MEMBRANE SYSTEMS.
 2. CLEAN METAL AND MEMBRANE WITH EVERGUARD® TPO CLEANER AND LET DRY.
 3. PRIME THE METAL ONLY WITH EVERGUARD® TPO PRIMER. DO NOT SPILL PRIMER ON WELDED SEAM AREA.
 4. HOT-AIR WELD THE MEMBRANE TO MEMBRANE AREA USING EITHER A ROBOTIC OR HAND WELDER TO SPEC.



Visit gaf.com

For additional information, contact GAF Technical Support at **1-800-766-3411** or technicalquestions@gaf.com

We protect what matters most™

