

Installation Guide for M-Weld Gravel Stop MB Fascia Type B

For Built Up and Modified Roofs

1 CAMPUS DRIVE, PARSIPPANY, NJ 07054 USA
973-628-3000
WWW.GAF.COM

The GAF logo consists of the letters "GAF" in a bold, white, sans-serif font, centered within a solid red square.

Install Guide for
M-Weld Gravel Stop
MB Fascia Type B
 (For Build Up or Modified Roofs)



ANSI/SPRI/FM4435/ES-1 TESTED

NOTES:
 #1 - Isolate all metal parts from ACQ treated wood or other galvanically incompatible material with appropriate membrane material.
 #2 - Appliance attachments, such as lightning rods, signs, or antennae that penetrate the edge system, induce a galvanic reaction, or otherwise compromise the effectiveness of the roof edge system, shall be eliminated or isolated to prevent problems per ANSI/SPRI/FM4435/ES-1. Lightning protection systems for example must not be directly affixed to the product provided by OMG. Consult OMG for alternative attachment suggestions.

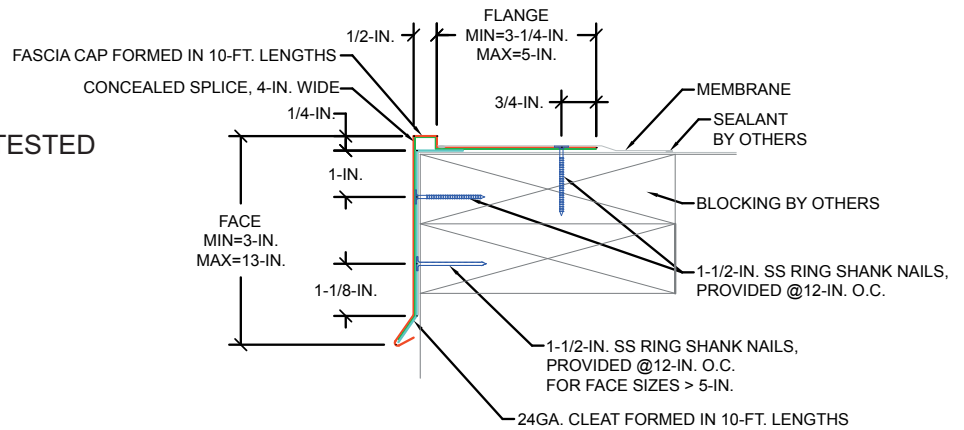

FOR MASONRY APPLICATIONS, PLEASE CONTACT US.
 CONTACT US FOR APPROPRIATE RECOMMENDATIONS NEEDED TO MEET/EXCEED
 ANSI/SPRI/FM4435/ES-1 DESIGN CRITERIA

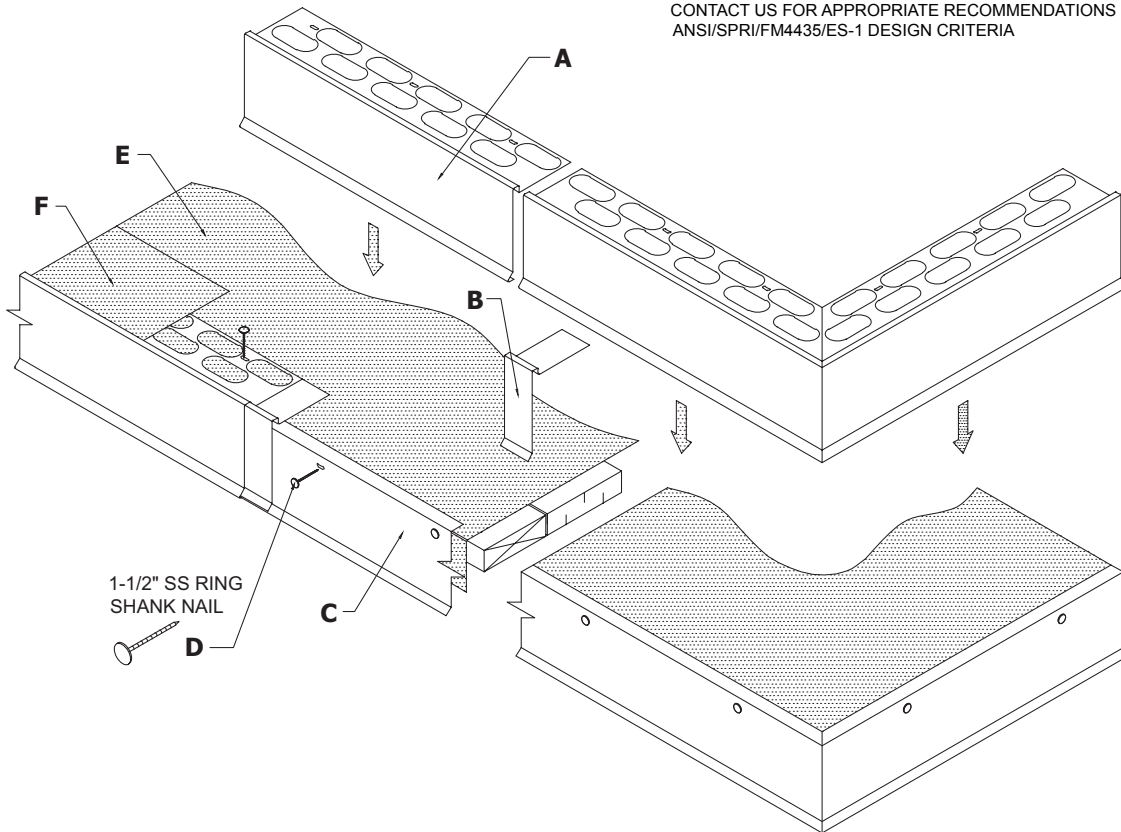

A. Formed Fascia Cover
 10'-0" Lengths

B. Concealed Joint Splice
 4" Lengths

C. Galvanized Steel Anchor Cleat
 10'-0" Lengths

D. 1-1/2" SS Ring Shank Nail
 at 12" o.c. (6" from ends)
 (Included & Required)

E. Base Ply
 (By Installer)

F. Strip-In or Cap Sheet
 (By Installer)

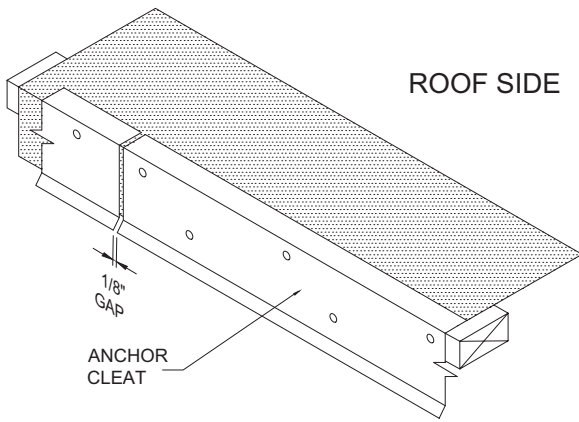

STEP 1: Installing Anchor Cleat

Place the top lip of the continuous anchor cleat squarely on the top edge of the base ply and treated wood nailing plate. Press cleats securely in position and nail through the pre-punched holes with 1-1/2" ss ring shank nails provided. For miter application, fit into corner as required to maintain a continuous anchor cleat line. Then nail at a min. 6" in each direction from the corner or closer at special conditions. Maintain a 1/8" gap between adjacent cleat pieces.

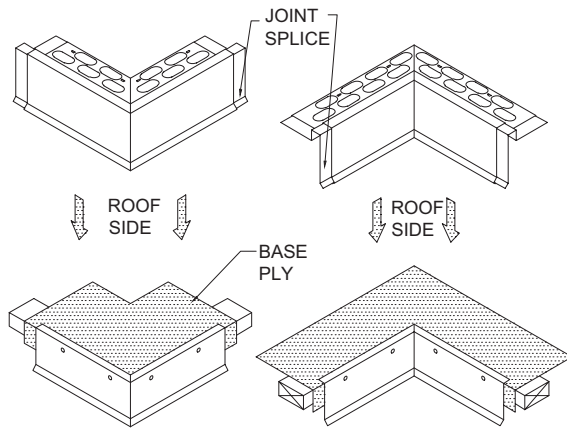

STEP 2: Installing Fascia Miters

Locate the miters and concealed joint splices for the appropriate corners. Place a concealed joint splice under each end of the miter sections. Install the miter by hooking the drip of the fascia miter onto the drip of the cleat and rotate back onto the roof. Fasten with 1-1/2" ss ring shank nails provided in pre-punched holes.

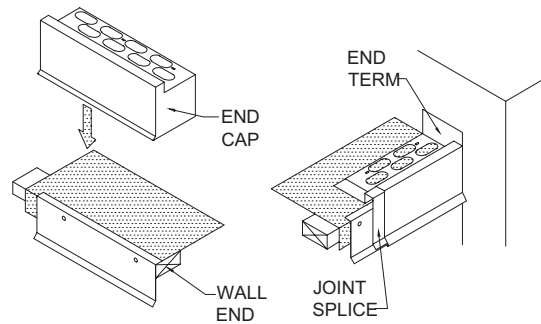

STEP 3: Installing Fascia End Caps and End Terms

Install the fascia end caps and end terms by hooking the drip of the fascia onto the drip of the cleat and rotate back onto the roof. Fasten with 1-1/2" ss ring shank nails provided in pre-punched holes.

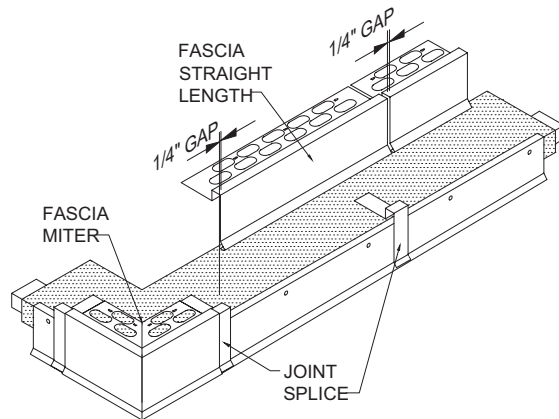

STEP 4: Installing Fascia Straight Lengths

Place a concealed joint splice in the opposite end of the installed miter or end cap. Install the fascia by hooking the drip of the fascia onto the drip of the cleat and rotate back onto the roof. Fasten with 1-1/2" ss ring shank nails provided in pre-punched holes. **Allow a 1/4" gap between fascia sections for thermal expansion.** Consider lengths of all straight pieces prior to cutting to avoid creating relatively short sections of fascia adjacent to full length sections.

Note: There should be a joint splice at every joint.

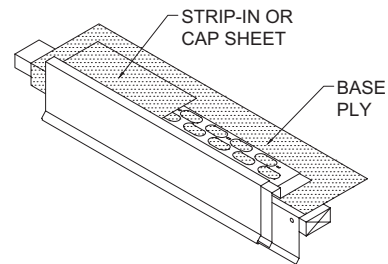

STEP 5: Installing Strip-In or Cap Sheet

Install strip-in ply or cap sheet per roofing manufacturer's instructions.