

**GAF**

We  
protect  
what  
matters  
most™

Version  
2.0

# UNITED COATINGS™ LIQUID-APPLIED ROOFING

## Application & Specifications Manual



[gaf.com](http://gaf.com)

# United Coatings™ Liquid-Applied Roofing

Application & Specifications Manual

## TABLE OF CONTENTS

<b>Welcome</b>	3
<b>Section 1: Guides</b>	
Product Guide	6
Cleaner & Primer Guide	8
Seam Treatment Guide	9
Guarantee/Warranty	10
<b>Section 2: Substrate Preparation</b>	
General Substrate Conditions	12
Moisture Survey	12
<b>Repair</b>	
Damaged Substrate Treatment: Metal	13
Damaged Substrate Treatment: Non-Metal	14
<b>Cleaning Procedures</b>	
Treatment	15
<b>General Substrate Preparation</b>	
Metal	16
Spray Polyurethane Foam	19
TPO	20
PVC & Hypalon®	21
EPDM	22
Smooth & Granulated Asphaltic	23
Structural Concrete	24
<b>Adhesion Testing</b>	
Field Peel Adhesion	25
<b>Section 3: Quick Spec Directory</b>	
<b>Roof Mate™</b>	<b>27</b>
Roof Mate™ over Metal	28
Roof Mate™ over TPO	29
Roof Mate™ over PVC	30
Roof Mate™ over Hypalon®	31
Roof Mate™ over EPDM	32
Roof Mate™ over Smooth Asphaltic	33
Roof Mate™ over Granulated Asphaltic	34
Roof Mate™ over Structural Concrete	35
Roof Mate™ over Corrugated Structural Transite Panels	36
<b>Unisil II</b>	<b>37</b>
Unisil II over Metal	38
Unisil II over PVC	39
Unisil II over Hypalon®	40
Unisil II over EPDM	41
Unisil II over Smooth Asphaltic	42
Unisil II over Granulated Asphaltic	43
Unisil II over Structural Concrete	44
Unisil II over Corrugated Structural Transite Panels	45
Unisil II over Spray Polyurethane Foam	46
Unisil II over Aged TPO	47
<b>Unisil HS II</b>	<b>48</b>
Unisil HS II over Metal	49
Unisil HS II over PVC	50
Unisil HS II over Hypalon®	51
Unisil HS II over EPDM	52
Unisil HS II over Smooth Asphaltic	53
Unisil HS II over Granulated Asphaltic	54
Unisil HS II over Structural Concrete	55
Unisil HS II over Corrugated Structural Transite Panels	56
Unisil HS II over Spray Polyurethane Foam	57
Unisil HS II over Aged TPO	58
<b>Elastuff® 101 With Elastuff® 103</b>	<b>59</b>
Elastuff® 101 with Elastuff® 103 over Metal	60
Elastuff® 101 with Elastuff® 103 over Smooth Asphaltic	61
Elastuff® 101 with Elastuff® 103 over Granulated Asphaltic	62
Elastuff® 101 with Elastuff® 103 over Structural Concrete	63
Elastuff® 101 with Elastuff® 103 over Corrugated Structural Transite Panels	64
Elastuff® 101 with Elastuff® 103 over Spray Polyurethane Foam	65

# TABLE OF CONTENTS

<b>Surface Seal SB</b>	<b>66</b>
Surface Seal SB over Metal	67
Surface Seal SB over EPDM	68
Surface Seal SB over Smooth Asphaltic	69
Surface Seal SB over Granulated Asphaltic	70
Surface Seal SB over Structural Concrete	71
<b>Diathon®</b>	<b>72</b>
Diathon® over Spray Polyurethane Foam	73
<b>Kymax™ + United Coatings™</b>	<b>74</b>
Roof Mate™ and Kymax™ over Metal	75
Roof Mate™ and Kymax™ over TPO	76
Roof Mate™ and Kymax™ over PVC	77
Roof Mate™ and Kymax™ over Hypalon®	78
Roof Mate™ and Kymax™ over EPDM	79
Roof Mate™ and Kymax™ over Smooth & Granulated Asphaltic	80
Roof Mate™ and Kymax™ over Structural Concrete & Corrugated Structural Transite Panels	81
Kymax™ Logo Work	82
Kymax™ Metal Restoration	83
<b>Roofshield® I.S.</b>	<b>84</b>
Roofshield® I.S. over TPO (RST Sprayer)	85
Roofshield® I.S. over TPO (CJ Sprayer)	86
Roofshield® I.S. over PVC (RST Sprayer)	87
Roofshield® I.S. over PVC (CJ Sprayer)	88
Roofshield® I.S. over Hypalon® (RST Sprayer)	89
Roofshield® I.S. over Hypalon® (CJ Sprayer)	90
Roofshield® I.S. over EPDM (RST Sprayer)	91
Roofshield® I.S. over EPDM (CJ Sprayer)	92
Roofshield® I.S. over Granulated Asphaltic (RST Sprayer)	93
Roofshield® I.S. over Granulated Asphaltic (CJ Sprayer)	94
Roofshield® I.S. over Structural Concrete (RST Sprayer)	95
Roofshield® I.S. over Structural Concrete (CJ Sprayer)	96
Roofshield® I.S. over Corrugated Structural Transite Panel (RST Sprayer)	97
Roofshield® I.S. over Corrugated Structural Transite Panel (CJ Sprayer)	98
Roofshield® I.S. over Metal (RST Sprayer)	99
Roofshield® I.S. over Metal (CJ Sprayer)	100
<b>Section 4: Care &amp; Preventative Maintenance</b>	
Overview	102
General Care & Preventative Maintenance Recommendations	102
Semi-Annual Inspections	103
Inspection Checklist	105
Roof Specific Leak Investigation	106
Emergency Repairs	106
Roof Alterations	107
<b>Section 5: Architectural Detail Drawings</b>	
LAR-106A Seam Flashing – Ribbed Panels	110
LAR-106B Seam Flashing – Corrugated Panels	110
LAR-106C Seam Flashing – Standing Seam Panels	111
LAR-106D Seam Flashing – J Panels	111
LAR-106E Seam Flashing – Ribbed J-Panels	112
LAR-110 Ridge Cap (Elevated)	112
LAR-202 Metal Roof Edge Fascia Cap	113
LAR-302 Wall Flashing- Over Non Metal Systems	113
LAR-303 General Equipment Curb Flashing	114
LAR-307 Skylight Curb	114
LAR-309 HVAC Curb/Scuttle Hatch Flashing	115
LAR-401 Control Joint - Concrete Deck	115
LAR-502 Pipe Flashing - Over Sprayed Polyurethane Foam	116
LAR-503 Pipe Flashing	116
LAR-506 Penetration Pocket - Double Penetration	117
LAR-510 Fabric Reinforced Drain	117
LAR-512 New Installation Drain Sump Flashing - Over Sprayed Polyurethane Foam	118
LAR-517 Flush Skylight	118

## WELCOME

Thank you for consulting Version 2.0 of the United Coatings™ Liquid-Applied Roofing Application & Specifications Manual. This manual contains the latest information relating to the application of GAF's United Coatings™ Liquid-Applied roofing systems, and is based on our years of experience in the commercial roofing field. It has been prepared as a general guide to assist architects, engineers, roofing contractors, and owners in the use of our liquid-applied coating systems. You can find further information at [www.gaf.com](http://www.gaf.com), or contact GAF at (800-766-3411).

## ABOUT GAF

As North America's largest roofing manufacturer, GAF proudly offers a comprehensive portfolio of award-winning, innovative roofing products for both residential and commercial properties. Supported by an extensive national network of certified contractors, GAF has built its reputation—and its success—on its steadfast commitment to Advanced Quality, Industry Expertise, and Solutions Made Simple.

GAF offers all major low-slope roofing technologies, including repair and maintenance products and roof restoration systems, as well as new roofing systems (BUR, modified bitumen, TPO, PVC, and liquid-applied systems). GAF has developed single-ply and asphaltic membranes with excellent durability and high reflectivity to meet the most rigorous industry standards while helping commercial property owners and designers reduce energy consumption.

For more information about GAF, visit us at [www.gaf.com](http://www.gaf.com).

## SERVICES

- GAF has a network of field representatives to supply and inspect its quality roofing systems throughout North America.
- GAF has a network of distributors to supply its quality roof systems throughout North America.
- Our GAF Technical Support Services allows you to contact us directly to speak with a representative about specifications, applications, code approvals, and product information. The GAF Technical Support Services number is 800-766-3411.
- Architectural Information Services (AIS) is a specification service that allows you to specify an approved GAF roofing systems based on your specific roofing needs and we will send you a general specification for that roofing system, including product description, application method, and detail drawings based on the information you provided. The phone number for AIS is 800-522-9224.
- Our Tapered Design Group (TDG) is one of the many services available to our customers to help reduce their hassles. We provide tapered insulation take-offs for architects, contractors, and distributors nationwide. Just send your roof plans and specifications to [tdg@gaf.com](mailto:tdg@gaf.com). The phone number for TDG is 800-766-3411.
- Our CARE (Center for the Advancement of Roofing Excellence) program trains industry professionals in proper roofing techniques. Professional, educational programs geared specifically to the roofing industry - given by experts in the roofing industry.
- Visit GAF on the web at [www.gaf.com](http://www.gaf.com) for extensive product information, specifications, and technical literature.

## DISCLAIMER

- GAF manufactures and sells roofing materials and does NOT practice architecture or engineering. GAF is NOT responsible for the performance of its products when damage to its products is caused by such things as improper building design or construction flaws.
- The design responsibility remains with the architect, engineer, roofing contractor, or owner, and construction details illustrated and described herein are furnished solely for guidance purposes. These guidelines should not be construed as being all-inclusive, nor should they be considered a substitute for good application practices.
- Under no circumstances does GAF have any liability for costs or expenses arising out of or associated with the pre-existing presence of asbestos-containing materials or any other allegedly hazardous substances or materials on the roof to which the new GAF roofing materials are being applied.
- Information contained in this manual is presented in good faith and, to the best of GAF's knowledge, does not infringe upon any patents, foreign or domestic.
- As a part of its continuing efforts to improve the performance of its products, GAF periodically makes changes to its products and application specifications. The Company reserves the right to change or modify, at its discretion, any of the information, requirements, specifications or policies contained herein. This manual supersedes all catalogs and previous manuals.

## GENERAL DESIGN CONSIDERATIONS

### HOW TO DETERMINE IF A ROOF IS A GOOD CANDIDATE FOR COATING

#### When installed on a new roof, a roof coating should:

- Be a component part of the roofing system. This will ensure compatibility with the system and enhance overall performance of the system.
- Be installed after the roof has weathered as necessary. Weathering periods may vary depending upon the type of system to which the coating will be applied. Use of a primer may also be required for certain substrates to ensure adequate adhesion.

#### When installed on an existing roof, a roof coating should:

- Be compatible with the existing roof.
- Help extend the remaining service life of the existing roof. Although a coating cannot add life back to a roof already beyond its service life, it can prevent a roof from aging as quickly as it would without the coating.
- Only be applied to a roof that drains properly. Some coatings may be adversely affected by the presence of ponding water. Therefore, areas of the existing roof that pond water should be repaired prior to coating.
- Only be applied to non-leaking roofs. While coatings may help seal some pinhole leaks not visible to the naked eye, they will not generally find and repair existing leaks. Accordingly, existing roof leaks will need to be identified and repaired prior to coating. Allow repairs to fully dry prior to coating.

# SECTION 1

## Guides

## Product Guide

Type	Product	Description	Base/Cure	VOC (g/L)	% Solids by Volume
Primers & Cleaner	Acrylex 400 Primer	Water-Based Acrylic Primer For Metal	Water-Based	<100	36
	CleanAct Rinsable Primer	Water-Based Rinsable Primer For EPDM	Water-Based	n/a	n/a
	Epoxy Primer	Water-Based Epoxy Primer For Concrete and Porous Substrates	Water-Based	<120	10.4
	Lock-Down Primer	Moisture-Cure Urethane Primer For Corrosion Protection On Metal Surfaces	Solvent Based/ Moisture-Cure	<420	55
	SureBond Primer	Water-Based Acrylic Primer For Chalky Surfaces	Water-Based	<200	23
	TPO Red Primer	Solvent-Based Primer For TPO Roofs	Solvent-Based	<100	1
	UniBase Primer	Water-Based Acrylic Penetrating Primer and Asphalt Bleed Blocker	Water-Based	<50	40
	Unisil Primer (Part A & B)	High Build Water-Based Epoxy Primer For Concrete and Porous Substrates	Water-Based	<100	42
	UniTile LV Sealer (Part A & B)	Solvent-Based Epoxy Penetrating Primer For Sealing Porous Surfaces	Two-Part	<420	53
	XR-2000 Primer	Water-Based Acrylic Primer For Kynar Coated Metal	Water-Based	<170	40
	United Cleaning Concentrate (UCC)	Water-Based Roof, Wall and Deck Surface Cleaner	Water-Based	n/a	n/a
	FireOut™ Fire Barrier Coating	Water-Based Coating For Wood Decks	Water-Based	<50	73
	United Coatings™ Acron 60 Roof Coating	Water-Based Acrylic Coating For Spray Polyurethane Foam	Water-Based	<50	60
	United Coatings™ Diathon® Base Roof Coating	Water-Based Acrylic Base Coat For Spray Polyurethane Foam	Water-Based	<50	51
	United Coatings™ Diathon® DS Roof Coating	Water-Based Acrylic Top Coat For Spray Polyurethane Foam	Water-Based	<50	60
	Roof Coatings	United Coatings™ Diathon® HT Roof Coating	High Tensile Water-Based Top Coat For Spray Polyurethane Foam	Water-Based	<50
United Coatings™ Diathon® OS Roof Coating		Quick Set Water-Based Top Coat For Spray Polyurethane Foam	Water-Based	<50	53
United Coatings™ Diathon® Roof Coating		Water-Based Acrylic Top Coat For Spray Polyurethane Foam	Water-Based	<50	53
United Coatings™ Elastuff® 101 Base Roof Coating		Aromatic Polyurethane Base Coat	Solvent Based/ Moisture-Cure	<250	80
United Coatings™ Elastuff® 103 Roof Coating (Part A & B)		Aliphatic Polyurethane Top Coat	Two-Part	<250	58
United Coatings™ EnergyCote™ Roof Coating		Water-Based Touch-Up Coating For EnergyCap Membranes	Water-Based	<50	51
United Coatings™ FireShield® MB Roof Coating		Acrylic Coating with Fire-Retardants	Water-Based	<50	48
United Coatings™ Kymax™ Coating		PVDF Fluoropolymer Top Coat	Water-Based	<250	36
United Coatings™ Roof Mate™ Base Coating		Water-Based Acrylic Base Coat	Water-Based	<50	51
United Coatings™ Roof Mate™ Coating		Water-Based Acrylic Top Coat	Water-Based	<50	53
United Coatings™ Roof Mate™ HT Coating		High Tensile Water-Based Acrylic Top Coat	Water-Based	<50	52

## Product Guide (continued)

Type	Product	Description	Base/Cure	VOC (g/L)	% Solids by Volume
Roof Coatings (Cont.)	United Coatings™ Roof Mate™ MB Plus Coating	Bleed Blocking Water-Based Acrylic Coating	Water-Based	<50	54
	United Coatings™ Roof Mate™ OS Coating	Quick Set Water-Based Acrylic Coating	Water-Based	<50	53
	United Coatings™ Roof Mate™ TCM Coating	Water-Based Acrylic Coating	Water-Based	<50	58
	United Coatings™ Roof Mate™ WOB Coating	Water-Based Coating Without Biocides	Water-Based	<50	58
	United Coatings™ Roofshield® Coating	Water-Based Acrylic Coating	Water-Based	<50	58
	United Coatings™ Roofshield® I.S.	Water-Based Acrylic Coating	Water-Based	<50	54
	United Coatings™ Surface Seal SB Roof Coating	Solvent-Based Thermoplastic Coating	Solvent-Based	<450	50
	United Coatings™ Unisil HS II Roof Coating	High Solids Silicone Coating	Moisture-Cure	<50	96
	United Coatings™ Unisil II Roof Coating	Solvent-Based Silicone Coating	Solvent-Based	<250	68
	United Coatings™ Acrysheen Sealer	Water-Based Penetrating Sealer	Water-Based	<100	18
	United Coatings™ Aquathon® Wall Coating	Water-Based Coating For Masonry Walls	Water-Based	<50	55
	United Coatings™ CanyonTone™ Clear Wall Coating	Clear Coat For Concrete, Brick, and Masonry Walls	Water-Based	<25	5
	United Coatings™ CanyonTone™ Stain	For Concrete, Brick, and Masonry Walls	Water-Based	<100	24
	United Coatings™ Elastuff® 120 Coating - Part A Mastic	Two-Part Urethane Coating	Two-Part	<508	100
United Coatings™ Elastuff® 120 Coating Part B Mastic	Two-Part Urethane Coating	Two-Part	<508	100	
United Coatings™ Elastuff® 120 Coating Part B Roller Grade	Two-Part Urethane Coating	Two-Part	<25	100	
United Coatings™ Elastuff® 120 Coating Part B Spray Grade	Two-Part Urethane Coating	Two-Part	<25	100	
United Coatings™ Rhino Top Smooth Coating	Water-Based Epoxy Modified Coating	Water-Based	<250	34	
United Coatings™ Rhino Top Textured Coating	Water-based epoxy modified textured coating	Water-Based	<100	41	
Architectural & Wall	FlexSeal™ Caulk Grade Sealant	Elastomeric Sealant	Solvent-Based	<300	75
	FlexSeal™ Sealant	Self-Leveling Elastomeric Sealant	Solvent-Based	<300	66
	United Coatings™ PMMA Flashing Resin	Two-part PMMA Flashing	Two-Part	<25	58
	United Coatings™ PMMA Fleece	Non-Woven, Needle-Punched Polyester Fabric Reinforcement	n/a	n/a	n/a
	United Coatings™ Roof Mate™ Butter Grade Flashing	Water-Based Acrylic Flashing	Water-Based	<50	58
	United Coatings™ Roof Mate™ Fabric	Non-Woven Stitch-Bond Polyester Reinforcement	n/a	n/a	n/a
	United Coatings™ Roof Mate™ Liquid Fabric	High Strength Water-Based Acrylic Flashing	Water-Based	<50	55
	United Coatings™ Roof Mate™ Spray Grade Flashing	Sprayable Water-Based Acrylic Flashing	Water-Based	<50	56
	United Coatings™ Roof Mate™ WOB Flashing	Water-Based Flashing Without Biocides	Water-Based	<60	58
	United Coatings™ UniCap Fastener Cover	Self-Adhering Aluminum Caps For Fasteners	n/a	n/a	n/a
	United Coatings™ Unisil Fiber Bulking Agent	Glass Fiber Bulking Agent	n/a	n/a	n/a
	United Coatings™ Unisil Silicone Flashing	Silicone Sealant	Moisture-Cure	<50	95
	United Coatings™ UniTape Seam Tape	Self-Adhering Woven Polyester Seam Tape	n/a	n/a	n/a
	Flashing, Sealants & Accessories	United Coatings™ Roof Mate™ MB Plus Coating	Bleed Blocking Water-Based Acrylic Coating	Water-Based	<50
United Coatings™ Roof Mate™ OS Coating		Quick Set Water-Based Acrylic Coating	Water-Based	<50	53
United Coatings™ Roof Mate™ TCM Coating		Water-Based Acrylic Coating	Water-Based	<50	58
United Coatings™ Roof Mate™ WOB Coating		Water-Based Coating Without Biocides	Water-Based	<50	58
United Coatings™ Roofshield® Coating		Water-Based Acrylic Coating	Water-Based	<50	58
United Coatings™ Roofshield® I.S.		Water-Based Acrylic Coating	Water-Based	<50	54
United Coatings™ Surface Seal SB Roof Coating		Solvent-Based Thermoplastic Coating	Solvent-Based	<450	50
United Coatings™ Unisil HS II Roof Coating		High Solids Silicone Coating	Moisture-Cure	<50	96
United Coatings™ Unisil II Roof Coating		Solvent-Based Silicone Coating	Solvent-Based	<250	68
United Coatings™ Acrysheen Sealer		Water-Based Penetrating Sealer	Water-Based	<100	18
United Coatings™ Aquathon® Wall Coating		Water-Based Coating For Masonry Walls	Water-Based	<50	55
United Coatings™ CanyonTone™ Clear Wall Coating		Clear Coat For Concrete, Brick, and Masonry Walls	Water-Based	<25	5
United Coatings™ CanyonTone™ Stain		For Concrete, Brick, and Masonry Walls	Water-Based	<100	24
United Coatings™ Elastuff® 120 Coating - Part A Mastic		Two-Part Urethane Coating	Two-Part	<508	100
United Coatings™ Elastuff® 120 Coating Part B Mastic	Two-Part Urethane Coating	Two-Part	<508	100	
United Coatings™ Elastuff® 120 Coating Part B Roller Grade	Two-Part Urethane Coating	Two-Part	<25	100	
United Coatings™ Elastuff® 120 Coating Part B Spray Grade	Two-Part Urethane Coating	Two-Part	<25	100	
United Coatings™ Rhino Top Smooth Coating	Water-Based Epoxy Modified Coating	Water-Based	<250	34	
United Coatings™ Rhino Top Textured Coating	Water-based epoxy modified textured coating	Water-Based	<100	41	
FlexSeal™ Caulk Grade Sealant	Elastomeric Sealant	Solvent-Based	<300	75	
FlexSeal™ Sealant	Self-Leveling Elastomeric Sealant	Solvent-Based	<300	66	
United Coatings™ PMMA Flashing Resin	Two-part PMMA Flashing	Two-Part	<25	58	
United Coatings™ PMMA Fleece	Non-Woven, Needle-Punched Polyester Fabric Reinforcement	n/a	n/a	n/a	
United Coatings™ Roof Mate™ Butter Grade Flashing	Water-Based Acrylic Flashing	Water-Based	<50	58	
United Coatings™ Roof Mate™ Fabric	Non-Woven Stitch-Bond Polyester Reinforcement	n/a	n/a	n/a	
United Coatings™ Roof Mate™ Liquid Fabric	High Strength Water-Based Acrylic Flashing	Water-Based	<50	55	
United Coatings™ Roof Mate™ Spray Grade Flashing	Sprayable Water-Based Acrylic Flashing	Water-Based	<50	56	
United Coatings™ Roof Mate™ WOB Flashing	Water-Based Flashing Without Biocides	Water-Based	<60	58	
United Coatings™ UniCap Fastener Cover	Self-Adhering Aluminum Caps For Fasteners	n/a	n/a	n/a	
United Coatings™ Unisil Fiber Bulking Agent	Glass Fiber Bulking Agent	n/a	n/a	n/a	
United Coatings™ Unisil Silicone Flashing	Silicone Sealant	Moisture-Cure	<50	95	
United Coatings™ UniTape Seam Tape	Self-Adhering Woven Polyester Seam Tape	n/a	n/a	n/a	



## Cleaner & Primer Guide\*

Substrate		Recommend UCC**	United Coatings™					Elastuff®	
			Roof Mate™	RoofShield® I.S.	Diathon®	Surface Seal (Solvent)	Unisil II (Solvent)		Unisil HS II
Metal	Rusty Metal	Yes	Acrylex 400	Acrylex 400	n/a	Lock-Down Primer	No Primer	Lock-Down Primer	
	Severe Rusty Metal	Yes	Lock-Down Primer	Lock-Down Primer	n/a	Lock-Down Primer	No Primer	Lock-Down Primer	
	Kynar Coated Metal	Yes	XR-2000	n/a	n/a	n/a	XR-2000	n/a	
	Residual Asphalt	Yes	UniBase (or RM Base or MB Plus)	Roof Mate™ MB Plus	n/a	Unisil Primer	Unisil Primer	Unisil Primer	No Primer
	Smooth Asphaltic	Yes	RM Base (or MB Plus)	n/a	n/a	Unisil Primer	Unisil Primer	Unisil Primer	No Primer
Asphaltic (BUR, SBS, APP)	Granulated Asphaltic	Yes	UniBase (or RM Base or MB Plus)	Roof Mate™ MB Plus	n/a	Unisil Primer	Unisil Primer	Unisil Primer	No Primer
	TPO (new or aged)	Yes	TPO Red Primer	Unisil Primer	n/a	n/a	TPO Red Primer	TPO Red Primer	n/a
Single-Ply	PVC (aged)	Yes	Unisil Primer	Unisil Primer	n/a	n/a	Unisil Primer	Unisil Primer	n/a
	Hypalon® (aged)	Yes	No Primer	Unisil Primer	n/a	n/a	No Primer	Unisil Primer	n/a
EPDM	EPDM	No	CleanAct	CleanAct and TPO Red Primer	n/a	CleanAct	CleanAct	CleanAct and Unisil Primer	n/a
	SPF	No	n/a	n/a	No Primer	n/a	No Primer	No Primer	No Primer
Structural Concrete	Structural Concrete	Yes	Epoxy Primer	Epoxy Primer	n/a	UniTile LV Sealer	Unisil Primer	Unisil Primer	UniTile LV Sealer
	DensDeck & Securock	No	n/a	n/a	n/a	n/a	n/a	n/a	n/a
Other	Plywood	No	n/a	n/a	n/a	n/a	n/a	n/a	n/a
	ISO	No	n/a	n/a	n/a	n/a	n/a	n/a	n/a
Existing Acrylic Coating	Existing Acrylic Coating	Yes	No Primer	No Primer	No Primer	n/a	No Primer	Unisil Primer	n/a
	Existing Silicone Coating	Yes	n/a	n/a	n/a	n/a	No Primer	n/a	n/a
Corrugated Structural Transite Panels	Yes	Epoxy Primer	Epoxy Primer	n/a	UniTile LV Sealer	Unisil Primer	Unisil Primer	Unisil Primer	UniTile LV Sealer

\* Adhesion Test is required. If less than 2.0 lb/in, a primer may promote adhesion.

Refer to the Adhesion section within this manual

\*\* GAF United Cleaning Concentrate

# Liquid-Applied Seam Treatment Guide

Substrate		Roof Mate™	Diathon®	Surface Seal	Unisil II	Unisil HS II	Elastuff®	RoofShield I.S.	
		PRODUCT OPTIONS (CHOOSE ONE)							
Metal	Horizontal Seams	Butter Grade Flashing w/Roof Mate™ Fabric	N/A	FlexSeal™ w/Roof Mate™ Fabric	Unisil Flashing Grade w/ Roof Mate™ Fabric	Unisil Flashing Grade w/ Roof Mate™ Fabric	Elastuff® 101 w/Roof Mate™ Fabric	Butter Grade Flashing w/Roof Mate™ Fabric	
		Liquid Fabric**			Unisil w/Roof Mate™ Fabric	Unisil HS w/Roof Mate™ Fabric		Liquid Fabric**	
		Roof Mate™ Seam Tape or UniTape			Butter Grade Flashing w/Roof Mate™ Fabric	Roof Mate™ Seam Tape or UniTape		Roof Mate™ Seam Tape or UniTape	Roof Mate™ Seam Tape or UniTape
					Liquid Fabric**				
	Vertical Seams [Overlap and Trapezoidal seams MUST be treated; other types can forgo treatment if the seal/tape is intact or if the seam is double locked.]	Butter Grade Flashing	N/A	FlexSeal™	Unisil Flashing Grade	Unisil Flashing Grade	Elastuff® 101	Butter Grade Flashing	
		Liquid Fabric**			Unisil w/Unisil Fibers	Unisil HS w/Unisil Fibers		Liquid Fabric**	
Roof Mate™ Seam Tape or UniTape	Butter Grade Flashing	Roof Mate™ Seam Tape or UniTape			Roof Mate™ Seam Tape or UniTape	Roof Mate™ Seam Tape or UniTape			
	Liquid Fabric**								
Single-Ply	TPO [Limited and Emerald projects may forgo fabric at tight seams; loose seams require 3-coursing]	Butter Grade Flashing w/Roof Mate™ Fabric	N/A	N/A	Unisil Flashing Grade w/ Roof Mate™ Fabric	Unisil Flashing Grade w/ Roof Mate™ Fabric	N/A	Butter Grade Flashing w/Roof Mate™ Fabric	
		Roof Mate™ Seam Tape or UniTape			Unisil w/Roof Mate™ Fabric			Unisil HS II w/Roof Mate™ Fabric	Roof Mate™ Seam Tape or UniTape
	PVC or Hypalon® [Limited and Emerald projects may forgo fabric at tight seams; loose seams require 3-coursing]	Butter Grade Flashing w/Roof Mate™ Fabric	N/A	N/A	Unisil Flashing Grade w/ Roof Mate™ Fabric	Unisil Flashing Grade w/ Roof Mate™ Fabric	N/A	Butter Grade Flashing w/Roof Mate™ Fabric	
		Roof Mate™ Seam Tape or UniTape			Unisil w/Roof Mate™ Fabric	Unisil HS w/Roof Mate™ Fabric		Roof Mate™ Seam Tape or UniTape	
	Butter Grade Flashing w/Roof Mate™ Fabric				Roof Mate™ Seam Tape or UniTape				
	Roof Mate™ Seam Tape or UniTape								
EPDM [Limited and Emerald projects may forgo fabric at tight seams; loose seams require 3-coursing]	Butter Grade Flashing w/Roof Mate™ Fabric	N/A	FlexSeal™ w/Roof Mate™ Fabric	Unisil Flashing Grade w/ Roof Mate™ Fabric	Unisil Flashing Grade w/ Roof Mate™ Fabric	N/A	Butter Grade Flashing w/Roof Mate™ Fabric		
	Roof Mate™ Seam Tape or UniTape			Unisil w/Roof Mate™ Fabric	Unisil HS w/Roof Mate™ Fabric		Roof Mate™ Seam Tape or UniTape		
Butter Grade Flashing w/Roof Mate™ Fabric				Roof Mate™ Seam Tape or UniTape					
Roof Mate™ Seam Tape or UniTape									
Asphaltic	Smooth Asphaltic [Limited and Emerald projects may forgo fabric at tight seams; loose seams require 3-coursing]	Butter Grade Flashing w/Roof Mate™ Fabric	N/A	FlexSeal™ w/Roof Mate™ Fabric	Unisil Flashing Grade w/ Roof Mate™ Fabric	Unisil Flashing Grade w/ Roof Mate™ Fabric	Elastuff® 101 w/Roof Mate™ Fabric	N/A	
					Unisil w/Roof Mate™ Fabric	Unisil HS w/Roof Mate™ Fabric			
	Butter Grade Flashing w/Roof Mate™ Fabric	N/A			FlexSeal™ w/Roof Mate™ Fabric	Unisil Flashing Grade w/ Roof Mate™ Fabric	Unisil Flashing Grade w/ Roof Mate™ Fabric	Elastuff® 101 w/Roof Mate™ Fabric	Butter Grade Flashing w/Roof Mate™ Fabric
						Unisil w/Roof Mate™ Fabric	Unisil HS w/Roof Mate™ Fabric		
Spray Polyurethane Foam	N/A	No Treatment	N/A	No Treatment	No Treatment	No Treatment	No Treatment	N/A	
	Structural Concrete [Structural joints to be treated with backer rod and compatible sealant, then coated over with products listed here.]	Butter Grade Flashing w/Roof Mate™ Fabric	N/A	FlexSeal™ & Fabric	Unisil Flashing Grade w/ Roof Mate™ Fabric	Unisil Flashing Grade w/ Roof Mate™ Fabric	Elastuff® 101 w/Roof Mate™ Fabric	Butter Grade Flashing w/Roof Mate™ Fabric	
		Roof Mate™ Seam Tape or UniTape			Unisil w/Roof Mate™ Fabric	Unisil HS w/Roof Mate™ Fabric		Roof Mate™ Seam Tape or UniTape	
Butter Grade Flashing w/Roof Mate™ Fabric	N/A				FlexSeal™ & Fabric	Unisil Flashing Grade w/ Roof Mate™ Fabric	Unisil Flashing Grade w/ Roof Mate™ Fabric	Elastuff® 101 w/Roof Mate™ Fabric	Butter Grade Flashing w/Roof Mate™ Fabric
Roof Mate™ Seam Tape or UniTape		Unisil w/Roof Mate™ Fabric	Unisil HS w/Roof Mate™ Fabric	Roof Mate™ Seam Tape or UniTape					
		Butter Grade Flashing w/Roof Mate™ Fabric	N/A	FlexSeal™ & Fabric		Unisil w/Roof Mate™ Fabric	Unisil HS w/Roof Mate™ Fabric	Elastuff® 101 w/Roof Mate™ Fabric	Butter Grade Flashing w/Roof Mate™ Fabric
Roof Mate™ Seam Tape or UniTape	Unisil w/Roof Mate™ Fabric	Unisil HS w/Roof Mate™ Fabric			Roof Mate™ Seam Tape or UniTape				

\*\*Fabric is REQUIRED for Emerald Pledge™ Limited Warranties & Diamond Pledge™ ND L Roof Guarantees.

## Warranty Guide

		Emerald Pledge™ <sup>1</sup>			Diamond Pledge™ <sup>1</sup>		
		10 yr	15 yr	20 yr <sup>2</sup>	10 yr	15 yr	20 yr <sup>2</sup>
<b>UNITED COATINGS: Who can offer?</b>							
	Retail Customer	No			No		
	Authorized Contractors	Yes for Metal, No for Non-Metal			No		
	Master & Master Select Contractors	Yes			Yes		
	Premium Contractors	Yes			Yes		
<b>Requirements</b>							
	Moisture Survey for Non-Metal Roofs	Yes			Yes		
	Pre-Inspection/Approval	Yes, for jobs over 20k sq.ft.			Yes, for jobs over 20k sq.ft.		
	Interim Inspection	Yes, for jobs over 10k sq.ft.			Yes		
	Final Inspection	Yes			Yes		
	Maintenance Program	Yes			Yes		
	Transferrable	No			Yes		
	Warranty Registration	Yes			Yes		
<b>Coverage</b>							
	Manufacturing Defects	Yes			Yes		
	Ordinary Wear & Tear	Yes			Yes		
	Workmanship	No			Yes		
<b>Remedy</b>							
	Materials	Yes			Yes		
	Labor	Yes			Yes		

**NOTES:**

1. For Emerald Pledge™ Limited Warranties and Diamond Pledge™ NDL Roof Guarantees, products must be applied per specifications by contractors certified with GAF at the appropriate level. Other requirements and restrictions may apply. Contact GAF at 1-800-ROOF-411 for more information.
2. Pre-approval required for all 20-year Warranties/Guarantees by Field Services Director (or higher).

# **SECTION 2**

## Substrate Preparation

## GENERAL SUBSTRATE CONDITIONS

Preparation of the roof substrate is the responsibility of the installer, who must address and correct all of the conditions listed in this section.

- Examine substrates to receive new roofing. If any questions arise regarding the compatibility of United Coatings™ products with an existing substrate, installer shall prepare test patches to check adhesion.
- Do not proceed with the installation of the United Coatings™ coating system until compatibility and adhesion of United Coatings™ coating system has been verified by test patches and other preparatory work has been completed and unsatisfactory conditions have been corrected.
- Roof must have positive drainage. Substrate should not pond water for more than 48 hours after precipitation stops. GAF defines “ponding” as water that does not drain or dissipate from the roof surface within 48 hours after precipitation ends. Ponding can also result from other water sources, including improperly piped air conditioning condensate and steam condensate lines.
- Protect adjacent surfaces that will not be coated.
- Do not apply liquid-applied roofing products to surfaces unacceptable to GAF, or under inclement environmental conditions.
- Substrates must be clean, completely dry, and free of any debris before application of any liquid-applied products.
- United Coatings™ liquid-applied roofing products should not be used on heavy-traffic bearing substrates. If foot traffic is expected, a rooftop walkway system approved by GAF must be used.

Always contact GAF’s Technical Support Services at 800-766-3411 for questions regarding suitable substrates, materials for test patches, or if you require additional information.

## PROPER PREPARATION FOR ROOF TYPES

To ensure proper coating application, the existing roof membrane must be thoroughly cleaned. All dust, chalking film, bitumen exudate, greases or oils, and other loose debris should be removed prior to coating. Use caution when pressure washing to preserve the integrity of the existing roof membrane and to avoid damage to membrane seams (especially adhered seams). Allow roof to dry completely prior to priming and coating; depending on type of existing substrate and coating to be applied, use of a primer may be required. Any required roof or flashing repairs should be completed and allowed to adequately cure where necessary. Refer to specific sections of this manual for more information on roof preparation.

While rusted metal roofs can be coated, additional measures may be required. If the roof is affected by “white rust” (i.e., zinc or aluminum), it can be coated after cleaning. However, if the roof is affected by “red rust,” the rust must either be removed or treated with corrosion inhibiting primer. Additionally, all rusted fasteners should also be removed or treated with a corrosion inhibiting primer.

## WHAT IS BENEATH THE EXISTING ROOF SURFACE?

In membrane roof system, there is typically a layer of insulation beneath the membrane. If the roof has ever experienced leaks, it is possible that there are areas of wet insulation in the existing roofing system. All wet roof insulation must be removed and replaced prior to coating. While certain areas of wet insulation may be noticeable simply by walking on them, a moisture survey is recommended to more accurately determine areas of wet insulation.

Metal roofs are typically installed over a solid roof deck or over purlins and insulation. Examining the underside of the roof deck can reveal areas of wet insulation, deteriorated deck or other damage that needs to be repaired prior to coating.

## MOISTURE SURVEY

It is the responsibility of the roofing contractor to determine the suitability of any substrate to receive a GAF roof system. Roof moisture surveys are a common tool used to assist with this determination.

**In order to be eligible to receive a NDL Diamond Pledge™ roof guarantee, GAF requires that all liquid-applied applications receive a moisture survey to determine if moisture is present.**

- If the roof contains more than 25% moisture, then a liquid-applied application is not an option and a complete tear-off is required.

A roof **moisture survey** may include one of the following ways to determine if moisture is present in the existing roofing system: **IR scan, nuclear scan, core cuts\* and portable devices to indicate moisture. GAF reserves the right to determine the type of survey required.**

\*A minimum of three [3] core cuts for the first 100 squares and one [1] core cut per additional 100 squares are required to verify existing roof conditions are acceptable and/or to determine where moisture is present.

## REPAIR

Inspect and make all necessary repairs to damaged substrates. Refer to the Damaged Substrate Treatment section below for substrate-specific information.

Damaged Substrate Treatment: Metal	
Areas of Concern	Treatment
<b>Rust Areas</b>	<ul style="list-style-type: none"> <li>Severely damaged or rusted seams and/or fasteners must be replaced.</li> <li>Roof panels that are corroded to the point that they have holes must be replaced.</li> <li>Light rust areas must be treated to prevent further deterioration of metal panels. Surface should not have more than 20% rust.</li> </ul>
<b>Fasteners</b>	<ul style="list-style-type: none"> <li>All fasteners must be retightened or replaced as necessary. All stripped fasteners must be replaced with new larger fasteners.</li> <li>All deteriorated and missing fasteners must be replaced.</li> <li>All fasteners must be fully encapsulated with flashing grade coating or United Coatings™ UniCap Fastener Covers (refer to Product Data Sheets for specific application requirements).</li> </ul>
<b>Dented / Damaged Panels</b>	<ul style="list-style-type: none"> <li>Dents must be mechanically removed to the maximum extent possible.</li> <li>Cover damaged/broken ribs with a sheet metal cap and seal with flashing grade prior to fastening the cap with fasteners.</li> <li>Severely damaged roof panels must be replaced.</li> </ul>
<b>Excessive Gaps</b>	<ul style="list-style-type: none"> <li>Seal cracks, joints, penetrations, and curbs with appropriate materials as recommended.</li> <li>Contact GAF Technical Support Services for more information.</li> </ul>
<b>Seams</b>	<ul style="list-style-type: none"> <li>Repair all seams as needed. Refer to the <b>Seam Treatment Guide</b> for specific guidance.</li> <li>Contact GAF Technical Support Services for more information.</li> </ul>
<b>Open Ridge Vents</b>	<ul style="list-style-type: none"> <li>Replace or install sheet metal caps over the open ridge vents if rust is present on the inside and/or roof is located in a harsh environment (e.g., salt water areas).</li> <li>Do not seal weep holes on vents.</li> </ul>

## Damaged Substrate Treatment: Non-Metal

Substrate	Treatment
TPO	<ul style="list-style-type: none"> <li>Any areas where TPO has torn, cracked, and/or buckled must be repaired using compatible materials.</li> <li>Any wet insulation must be replaced.</li> <li>Allow at least 48 hours drying time after the cleaning process before application of liquid-applied products.</li> </ul>
PVC or Hypalon®	<ul style="list-style-type: none"> <li>Any areas where PVC or Hypalon® has torn, cracked, and/or buckled must be repaired using compatible materials.</li> <li>Any wet insulation must be replaced.</li> <li>Allow at least 48 hours drying time before application of liquid-applied products.</li> </ul>
Spray Polyurethane Foam	<ul style="list-style-type: none"> <li>All areas where the urethane foam has degraded must be scarified and re-foamed to create a smooth, workable substrate.</li> <li>Any areas where foam is wet/damaged must be removed and re-foamed.</li> </ul>
EPDM	<ul style="list-style-type: none"> <li>Any areas where EPDM has torn, cracked, and/or buckled must be repaired using compatible materials.</li> <li>Any wet insulation must be replaced.</li> </ul>
Mineral & Granule Surfaced BUR or Modified Bitumen (SBS & APP) OR Smooth Surfaced BUR or Modified Bitumen (SBS & APP)	<ul style="list-style-type: none"> <li>Any areas where asphaltic membranes have blistered, buckled, become wet and/or damaged must be removed and repaired using compatible materials.</li> <li>New BUR or modified bitumen repair materials must be allowed to weather at least 30 days before applying liquid-applied products.</li> <li>All areas where BUR or modified bitumen surfaces have significantly cracked (gaps 1/16" [1.6 mm] or greater in width and/or depth) must be repaired using flashing grade coating to create a smooth, workable substrate.</li> <li>Allow flashing grade coating at least 24 hours drying time before application of liquid-applied products. Areas with thicker applications may require additional drying time.</li> <li>Contact GAF for coating solutions for gravel surfaced roofs.</li> </ul>
Corrugated Structural Transite Panels	<ul style="list-style-type: none"> <li>All large or excessive gaps (greater than 1/4" [6 mm]) between roof panels must be filled or made flush with closed-cell foam strips or polyurethane foam to pre-fill voids.</li> <li>All fasteners must be retightened or replaced as necessary. All stripped fasteners must be replaced with larger fasteners.</li> <li>All deteriorated or missing fasteners must be replaced.</li> <li>All fasteners must be fully encapsulated with flashing grade or UniCap Fastener Covers.</li> <li>Repair all horizontal seams as necessary. Refer to the Seam Treatment Guide for specific guidance.</li> <li>Many of these panels can contain asbestos. Refer to the Environmental Considerations in the Cleaning Procedures section for further information.</li> </ul>
Wood OSB/Plywood/Tongue & Groove	<ul style="list-style-type: none"> <li>Any areas where substrate is rotten, wet and/or damaged must be removed and repaired using similar products.</li> <li>All large or excessive gaps (greater than 1/4" [6mm]) existing between roof panels and/or penetrations must be filled with flashing grade coating to create to a smooth, workable surface on the substrate.</li> <li>All fasteners must be retightened or replaced as necessary. All stripped fasteners must be replaced with larger fasteners.</li> <li>All deteriorated and missing fasteners must be replaced. All fasteners must be fully encapsulated with flashing grade.</li> </ul>
Structural Concrete	<ul style="list-style-type: none"> <li>All large or excessive gaps (greater than 1/4" [6 mm]) must be repaired using high-quality concrete grout. Grout must fully cure before applying liquid-applied products.</li> <li>Correct areas of ponding water.</li> </ul>

## CLEANING PROCEDURES

Treatment	
<b>General Surface Prep</b>	<ul style="list-style-type: none"> <li>Clean and prepare surfaces to receive liquid-applied roofing products. Remove all dirt, dust, loose and flaking particles, grease, oil, laitance, pollution fallout, and other contaminants that may interfere with proper adhesion.</li> <li>Use a stiff bristle push broom and/or pressure washing for cleaning and surface preparation.</li> <li>When encountering roof substrates that have living organisms such as algae, mold or fungus, <u>a sterilant such as 3:1 bleach solution</u> must be used to kill and remove these organisms during the roof cleaning.</li> </ul>
<b>Pressure Washing</b>	<ul style="list-style-type: none"> <li>Substrate must be pressure-washed with water and/or approved cleaner. Refer to the <i>Cleaner &amp; Primer Guide</i> for specific substrates and cleaning requirements.</li> <li>A minimum working pressure of 2,000 psi is to be used to remove all dirt, dust, chalking and waste products (oil, oil-based roof cements, solvents, grease, animal fats, etc.).</li> <li>Concrete, EPDM, and metal substrates should use a minimum working pressure of 3,000 psi.</li> <li>Care should be taken not to damage the roof surface or inject water into the substrate during washing.</li> <li>Allow at least 48 hours for drying time before the application of liquid-applied products.</li> </ul>
<b>Important! Environmental Considerations</b>	<ul style="list-style-type: none"> <li>Corrugated or structural transite panels are likely to contain significant amounts of asbestos, which may be released during pressure-washing. Asbestos dust is an extreme health hazard and a known carcinogen. It is the Installer's responsibility to check with state and local agencies regarding proper disposal, as well as the proper protection for workers exposed to this material.</li> <li>Roof wash-off catchment systems should be in place when required. Be sure to follow state and local requirements for roof-wash off catchments during the cleaning process.</li> </ul>



## GENERAL SUBSTRATE PREPARATION

Substrate Preparation: Metal	
Areas of Concern	Preparation
<b>Crickets</b>	<ul style="list-style-type: none"> <li>• Sheet metal crickets must be installed according to manufacturer's specifications.</li> <li>• New crickets must be sealed with FlexSeal™ Sealant under the flanges prior to mechanically fastening to the curb unit and metal roof panel.</li> <li>• Stitch-screw cricket flanges to the curb unit and metal roof panel while the FlexSeal™ Sealant is still wet using fasteners.</li> </ul>
<b>Ponding Water Areas</b>	<ul style="list-style-type: none"> <li>• Make every effort to eliminate all ponding water areas prior to coating application.</li> <li>• Treat ponding water areas which cannot be eliminated with Flex-Seal™ Sealant prior to application of other coatings.</li> </ul>
<b>Residual Asphalt</b>	<ul style="list-style-type: none"> <li>• Remove any existing asphaltic roof coating.</li> <li>• Any residual asphalt must be coated with the recommended coating/primer for the specific system (see Cleaner &amp; Primer Guide).</li> </ul>
<b>Pre-Finished Metal Panels</b>	<ul style="list-style-type: none"> <li>• If roof panel surfaces are known or suspected to contain Kynar-500, other fluoropolymers, or silicone, test patches must be prepared with and without the use of a recommended primer (see Cleaner &amp; Primer Guide). Based on test patch adhesion results, Installer should apply primer on pre-finished metal panels per specifications.</li> </ul>
<b>Pitch Pans</b>	<ul style="list-style-type: none"> <li>• Pitch pans must be capped with sheet metal to allow for proper sealing with United Coatings™ products. Contact GAF's Technical Support Services for more information.</li> </ul>
<b>Neoprene Pipe Boots</b>	<ul style="list-style-type: none"> <li>• Install neoprene boots prior to performing flashing work for certain types of pipe penetrations. Neoprene boots first must be sealed to the roof using a bead of FlexSeal™ Sealant prior to mechanically fastening.</li> </ul>
<b>Condensate Lines</b>	<ul style="list-style-type: none"> <li>• Condensate lines should be installed from the HVAC units to gutters as part of the overall roofing contract. The type of piping used for condensate lines may vary depending on local building codes.</li> <li>• Condensate lines must be securely fastened to panel ribs.</li> </ul>
<b>Gutter Straps</b>	<ul style="list-style-type: none"> <li>• All gutter straps that are fastened above roof panels must be fully encapsulated with the recommended coating, including the fasteners.</li> </ul>
<b>Gutters</b>	<ul style="list-style-type: none"> <li>• Trowel or brush apply FlexSeal™ Sealant to the interior or exterior gutter incorporating 12 inches (305 mm) of the recommended fabric at all gutter seams.</li> </ul>
<b>Cinch Straps at Panel End Laps</b>	<ul style="list-style-type: none"> <li>• Re-tighten cinch straps as necessary.</li> <li>• Surround each strap and fastener head with a bead of FlexSeal™ Sealant.</li> <li>• Fully inject FlexSeal™ Sealant into the cinch strap water channel, then seal the entire lap, strap, and fastener heads with a minimum 12 inch (305 mm) width of FlexSeal™ Sealant. Feather the FlexSeal™ Sealant out. Fabric is not required.</li> </ul>

## Substrate Preparation: Metal (Cont'd.)

Areas of Concern	Preparation
<b>Ridge Caps</b>	<ul style="list-style-type: none"> <li>• All ridge caps must be flashed with the recommended coating and fabric.</li> <li>• All voids and open areas in the ridge cap must be filled with polyurethane foam prior to application of the coating and fabric.</li> <li>• For metal "Z" closures which are located within 2 inches (51 mm) of the ridge cap edge, remove all exposed sealant and apply a liberal bead of the recommended seam coating to all sides of the "Z" closure where they intersect with both the roof panel and ridge cap.</li> </ul>
<b>Rakes</b>	<ul style="list-style-type: none"> <li>• All fixed rake details for the roof must be sealed with a minimum 12 inch (305 mm) width of the recommended coating and fabric. Embed the fabric between two layers of the coating, extending 6" (152 mm) up the vertical and 6" (152 mm) onto the base.</li> <li>• If fixed rake metal is fastened to the top of roof panel ribs and extends back onto the roof, trim off any excess metal and follow horizontal seam flashing procedures.</li> <li>• All voids and open areas must be filled with polyurethane foam prior to application of the coating and fabric.</li> </ul>
<b>Parapet Walls</b>	<ul style="list-style-type: none"> <li>• All parapet wall details within the roof system must be sealed with a minimum 12 inch (305 mm) width of the recommended coating and fabric. Embed the fabric between two layers of the coating, extending 6" (152 mm) up the vertical and 6" (152 mm) onto the base.</li> <li>• If parapet wall flashing metal is fastened to the top of roof panel ribs and extends back onto the roof, trim off any excess metal and follow horizontal seam flashing procedures.</li> <li>• All voids and open areas must be filled with polyurethane foam prior to application of the recommended coating and fabric.</li> <li>• Fabric must be cut around all fasteners so it lies flat. United Coatings™ UniCap fastener covers can alternatively be used.</li> </ul>
<b>Standing Seam Panels</b>	<ul style="list-style-type: none"> <li>• Contact GAF's Technical Support Services at 800-766-3411.</li> </ul>
<b>Curb Flashings</b>	<ul style="list-style-type: none"> <li>• All curb flashings, including cricket details, must be sealed with a minimum 12 inch (305 mm) width of the recommended coating and fabric. Embed the fabric between two layers of the coating, extending 6" (152 mm) up the vertical and 6" (152 mm) onto the base.</li> <li>• Encapsulate all fasteners using the recommended coating. Do not bridge fasteners.</li> <li>• The fabric must be cut around all fasteners so the fabric lies flat.</li> </ul>
<b>Penetrations</b>	<ul style="list-style-type: none"> <li>• The recommended coating and fabric must be applied around the base of all penetrations. Embed the minimum 12 inch (305 mm) width fabric between two layers of the coating, extending 6" (152 mm) up the vertical and 6" (152 mm) onto the base.</li> <li>• Cut the fabric to accommodate the shape of the penetration avoiding wrinkles.</li> </ul>
<b>Skylights</b>	<ul style="list-style-type: none"> <li>• Curb skylights must be treated in the same fashion as curb flashings.</li> <li>• After flashing work has been completed and the coating has cured, treat deteriorated fiberglass skylight panels with United Coatings™ Acrysheen Sealer.</li> </ul>

## Substrate Preparation: Metal (Cont'd.)

	Areas of Concern	Preparation
<b>VERTICAL SEAMS</b>	<b>Ribbed Seam</b>	<ul style="list-style-type: none"> <li>All ribbed panel vertical seams must be sealed with the recommended seam coating. Feather the coating until seams are no longer visible while brushing in the direction parallel to the seam.</li> </ul>
	<b>Standing Seam</b>	<ul style="list-style-type: none"> <li>All standing vertical seams must be sealed with a 1/2 inch (12 mm) bead of the recommended seam coating. Feather the coating until seams are no longer visible while brushing in the direction parallel to the seam.</li> </ul>
	<b>Standing "T" Seam</b>	<ul style="list-style-type: none"> <li>Both vertical seams of the standing "T" must be flashed with a 1/2 inch (12 mm) bead of the recommended seam coating and brushed into the seams.</li> </ul>
	<b>Inverted "J" Seam</b>	<ul style="list-style-type: none"> <li>In snowy climates and/or when roof leaks are suspected, re-crimping the short leg of the seam all the way under the horizontal portion of the inverted "J" seam is required. Brush or trowel-apply the recommended seam coating over the newly created single lock vertical seam. Portable seamers may be used to perform the re-crimping.</li> </ul>
	<b>Corrugated Seam</b>	<ul style="list-style-type: none"> <li>All corrugated panel vertical seams must be sealed with the recommended seam coating system. Feather the coating until seams are no longer visible while brushing in the direction parallel to the seam.</li> </ul>
	<b>Batten Seam</b>	<ul style="list-style-type: none"> <li>Both vertical seams of the batten must be flashed with a 1/2 inch (12 mm) bead of the recommended seam coating. Feather the coating until seams are no longer visible while brushing in the direction parallel to the seam.</li> </ul>
<b>HORIZONTAL SEAMS</b>	<b>Horizontal Seam</b>	<ul style="list-style-type: none"> <li>All seams must be reinforced with either fabric between two layers of the recommended coating or Roof Mate™ Liquid Fabric.</li> <li>The coating must be feathered at least 1 inch (25 mm) beyond each side of the 6 inch (152 mm) width to allow water to flow over the seam.</li> <li>Fabric must be cut around all fasteners so it lies flat.</li> <li>For ribbed roof panels, the fabric must be applied over panel ribs in continuous lengths. A minimum 2 inch (51 mm) overlap is required for all splices in fabric.</li> <li>Horizontal seams must be secured with fasteners on the high side of every other corrugation, spaced no more than 12 inches (305 mm) on center.</li> <li>The horizontal seam must be made flush by installing two fasteners per flute.</li> </ul>

## Substrate Preparation: Spray Polyurethane Foam (SPF)

Areas of Concern	Treatment
<b>Parapet Walls/Curb/ Penetration Flashings</b>	<ul style="list-style-type: none"> <li>• SPF is self-flashing and should be adhered to all adjacent surfaces.</li> <li>• Repair any minor separations from shrinkage with the specified flashing grade and fabric if necessary.</li> </ul>
<b>Skylights</b>	<ul style="list-style-type: none"> <li>• Curb skylights must be treated in the same fashion as curb flashings.</li> <li>• After flashing work has been completed and the coating has cured, treat deteriorated fiberglass skylight panels with United Coatings™ Acrysheen Sealer.</li> </ul>
<b>Gutters</b>	<ul style="list-style-type: none"> <li>• Trowel or brush apply FlexSeal™ Sealant to the interior or exterior gutter incorporating 12 inches (305 mm) of the recommended fabric at all gutter seams.</li> </ul>
<b>Pitch Pans</b>	<ul style="list-style-type: none"> <li>• Pitch pans must be capped with sheet metal to allow for proper sealing with United Coatings™ products.</li> <li>• Contact GAF Technical Support Services for more information.</li> </ul>
<b>Condensate Lines</b>	<ul style="list-style-type: none"> <li>• Condensate lines must be installed from HVAC units to gutters as part of the overall drainage system. The type of piping used for condensate lines may vary depending on local building codes.</li> <li>• Condensate lines must be securely fastened to the roof.</li> </ul>

## Substrate Preparation: TPO

Areas of Concern	Treatment
<b>Parapet Walls/ Curb Flashings</b>	<ul style="list-style-type: none"> <li>• Repair all open seams and any loose or failed terminations with in-kind materials welded in place prior to application of the recommended coating and fabric.</li> <li>• All parapet wall details within the roof system must be sealed with a minimum 12 inch (305 mm) width of the recommended coating and fabric. Embed the fabric between two layers of the coating, extending 6" (152 mm) up the vertical and 6" (152 mm) onto the base.</li> <li>• All curb flashings, including cricket details, must be sealed with a minimum 12 inch (305 mm) width of the recommended coating and fabric. Embed the fabric between two layers of the coating, extending 6" (152 mm) up the vertical and 6" (152 mm) onto the base.</li> <li>• Encapsulate all fasteners using the recommended coating. Do not bridge fasteners.</li> <li>• Fabric must be cut around all fasteners so it lies flat.</li> </ul>
<b>Penetrations</b>	<ul style="list-style-type: none"> <li>• The recommended coating and fabric must be applied around the base of all penetrations. Embed the minimum 12 inch (305 mm) width fabric between two layers of the coating, extending 6" (152 mm) up the vertical and 6" (152 mm) onto the base.</li> <li>• Cut the fabric to accommodate the shape of the penetration, avoiding wrinkles.</li> </ul>
<b>Skylights</b>	<ul style="list-style-type: none"> <li>• Curb skylights must be treated in the same fashion as curb flashings.</li> <li>• After flashing work has been completed and the coating has cured, treat deteriorated fiberglass skylight panels with United Coatings™ Acrysheen Sealer.</li> </ul>
<b>Gutters</b>	<ul style="list-style-type: none"> <li>• Trowel or brush apply FlexSeal™ Sealant to the interior or exterior gutter incorporating 12 inches (305 mm) of the recommended fabric at all gutter seams.</li> </ul>
<b>Pitch Pans</b>	<ul style="list-style-type: none"> <li>• Pitch pans must be capped with sheet metal to allow for proper sealing with United Coatings™ products.</li> <li>• Contact GAF Technical Support Services for more information.</li> </ul>
<b>Condensate Lines</b>	<ul style="list-style-type: none"> <li>• Condensate lines must be installed from HVAC units to gutters as part of the overall drainage system. The type of piping used for condensate lines may vary depending on local building codes.</li> </ul>

## Substrate Preparation: PVC & Hypalon®

Areas of Concern	Treatment
<b>Parapet Walls/ Curb Flashings</b>	<ul style="list-style-type: none"> <li>• Repair all open seams and any loose or failed terminations with in-kind materials prior to application of the recommended coating and fabric.</li> <li>• All parapet wall details within the roof system must be sealed with a minimum 12 inch (305 mm) width of the recommended coating and fabric. Embed the fabric between two layers of the coating, extending 6" (152 mm) up the vertical and 6" (152 mm) onto the base.</li> <li>• All curb flashings, including cricket details, must be sealed with a minimum 12 inch (305 mm) width of the recommended coating and fabric. Embed the fabric between two layers of the coating, extending 6" (152 mm) up the vertical and 6" (152 mm) onto the base.</li> <li>• Encapsulate all fasteners using the recommended coating. Do not bridge fasteners.</li> <li>• Fabric must be cut around all fasteners so it lies flat.</li> </ul>
<b>Penetrations</b>	<ul style="list-style-type: none"> <li>• The recommended coating and fabric must be applied around the base of all penetrations. Embed the minimum 12 inch (305 mm) width fabric between two layers of the coating, extending 6" (152 mm) up the vertical and 6" (152 mm) onto the base.</li> <li>• Cut the fabric to accommodate the shape of the penetration, avoiding wrinkles.</li> </ul>
<b>Skylights</b>	<ul style="list-style-type: none"> <li>• Curb skylights must be treated in the same fashion as curb flashings.</li> <li>• After flashing work has been completed and the coating has cured, treat deteriorated fiberglass skylight panels with United Coatings™ Acrysheen Sealer.</li> </ul>
<b>Gutters</b>	<ul style="list-style-type: none"> <li>• Trowel or brush apply FlexSeal™ Sealant to the interior or exterior gutter incorporating 12 inches (305 mm) of the recommended fabric at all gutter seams.</li> </ul>
<b>Pitch Pans</b>	<ul style="list-style-type: none"> <li>• Pitch pans must be capped with sheet metal to allow for proper sealing with United Coatings™ products.</li> <li>• Contact GAF Technical Support Services for more information.</li> </ul>
<b>Condensate Lines</b>	<ul style="list-style-type: none"> <li>• Condensate lines must be installed from HVAC units to gutters as part of the overall drainage system. The type of piping used for condensate lines may vary depending on local building codes.</li> </ul>

## Substrate Preparation: EPDM

Areas of Concern	Treatment
<b>Parapet Walls/ Curb Flashings</b>	<ul style="list-style-type: none"> <li>• Repair all open seams and any loose or failed terminations with in-kind materials welded in place prior to application of the recommended coating and fabric.</li> <li>• All parapet wall details within the roof system must be sealed with a minimum 12 inch (305 mm) width of the recommended coating and fabric. Embed the fabric between two layers of the coating, extending 6" (152 mm) up the vertical and 6" (152 mm) onto the base.</li> <li>• All curb flashings, including cricket details, must be sealed with a minimum 12 inch (305 mm) width of the recommended coating and fabric. Embed the fabric between two layers of the coating, extending 6" (152 mm) up the vertical and 6" (152 mm) onto the base.</li> <li>• Encapsulate all fasteners using the recommended coating. Do not bridge fasteners.</li> <li>• Fabric must be cut around all fasteners so it lies flat.</li> </ul>
<b>Penetrations</b>	<ul style="list-style-type: none"> <li>• The recommended coating and fabric must be applied around the base of all penetrations. Embed the minimum 12 inch (305 mm) width fabric between two layers of the coating, extending 6" (152 mm) up the vertical and 6" (152 mm) onto the base.</li> <li>• Cut the fabric to accommodate the shape of the penetration, avoiding wrinkles.</li> </ul>
<b>Skylights</b>	<ul style="list-style-type: none"> <li>• Curb skylights must be treated in the same fashion as curb flashings.</li> <li>• After flashing work has been completed and the coating has cured, treat deteriorated fiberglass skylight panels with United Coatings™ Acrysheen Sealer.</li> </ul>
<b>Gutters</b>	<ul style="list-style-type: none"> <li>• Trowel or brush apply FlexSeal™ Sealant to the interior or exterior gutter incorporating 12 inches (305 mm) of the recommended fabric at all gutter seams.</li> </ul>
<b>Pitch Pans</b>	<ul style="list-style-type: none"> <li>• Pitch pans must be capped with sheet metal to allow for proper sealing with United Coatings™ products.</li> <li>• Contact GAF Technical Support Services for more information.</li> </ul>
<b>Condensate Lines</b>	<ul style="list-style-type: none"> <li>• Condensate lines must be installed from HVAC units to gutters as part of the overall drainage system. The type of piping used for condensate lines may vary depending on local building codes.</li> </ul>

## Substrate Preparation: Smooth & Granulated Surfaced Asphaltic

Areas of Concern	Treatment
<p><b>Parapet Walls/ Curb Flashings</b></p>	<ul style="list-style-type: none"> <li>• Repair all open seams and any loose or failed terminations with in-kind materials welded in place prior to application of the recommended coating and fabric.</li> <li>• All parapet wall details within the roof system must be sealed with a minimum 12 inch (305 mm) width of the recommended coating and fabric. Embed the fabric between two layers of the coating, extending 6" (152 mm) up the vertical and 6" (152 mm) onto the base.</li> <li>• All curb flashings, including cricket details, must be sealed with a minimum 12 inch (305 mm) width of the recommended coating and fabric. Embed the fabric between two layers of the coating, extending 6" (152 mm) up the vertical and 6" (152 mm) onto the base.</li> <li>• Encapsulate all fasteners using the recommended coating. Do not bridge fasteners.</li> <li>• Fabric must be cut around all fasteners so it lies flat.</li> </ul>
<p><b>Penetrations</b></p>	<ul style="list-style-type: none"> <li>• The recommended coating and fabric must be applied around the base of all penetrations. Embed the minimum 12 inch (305 mm) width fabric between two layers of the coating, extending 6" (152 mm) up the vertical and 6" (152 mm) onto the base.</li> <li>• Cut the fabric to accommodate the shape of the penetration, avoiding wrinkles.</li> </ul>
<p><b>Skylights</b></p>	<ul style="list-style-type: none"> <li>• Curb skylights must be treated in the same fashion as curb flashings.</li> <li>• After flashing work has been completed and the coating has cured, treat deteriorated fiberglass skylight panels with United Coatings™ Acrysheen Sealer.</li> </ul>
<p><b>Gutters</b></p>	<ul style="list-style-type: none"> <li>• Trowel or brush apply FlexSeal™ Sealant to the interior or exterior gutter incorporating 12 inches (305 mm) of the recommended fabric at all gutter seams.</li> </ul>
<p><b>Pitch Pans</b></p>	<ul style="list-style-type: none"> <li>• Pitch pans must be capped with sheet metal to allow for proper sealing with United Coatings™ products.</li> <li>• Contact GAF Technical Support Services for more information.</li> </ul>
<p><b>Condensate Lines</b></p>	<ul style="list-style-type: none"> <li>• Condensate lines must be installed from HVAC units to gutters as part of the overall drainage system. The type of piping used for condensate lines may vary depending on local building codes.</li> </ul>



## Substrate Preparation: Structural Concrete

Areas of Concern	Treatment
<b>Parapet Walls</b>	<ul style="list-style-type: none"> <li>• Repair all cracked, spalled and open concrete holes with an in-kind cementitious patch. Repair any loose or failed seams in concrete with similar materials as originally used. This is commonly a polyurethane sealant with a closed cell polyethylene backer rod.</li> <li>• All parapet wall details within the roof system must be sealed with a minimum 12 inch (305 mm) width of the recommended coating and fabric. Embed the fabric between two layers of the coating, extending 6" (152 mm) up the vertical and 6" (152 mm) onto the base.</li> <li>• Fabric must be cut around all fasteners so it lies flat.</li> </ul>
<b>Curb Flashings</b>	<ul style="list-style-type: none"> <li>• All curb flashings, including cricket details, must be flashed with at least a 12 inch (305 mm) width of the recommended coating and fabric.</li> <li>• Encapsulate all fasteners using the recommended coating. Do not bridge fasteners.</li> <li>• Fabric must be cut around all fasteners so it lies flat.</li> </ul>
<b>Penetrations</b>	<ul style="list-style-type: none"> <li>• The recommended coating and fabric must be applied around the base of all penetrations. Embed the minimum 12 inch (305 mm) width fabric between two layers of the coating, extending 6" (152 mm) up the vertical and 6" (152 mm) onto the base.</li> <li>• Cut the fabric to accommodate the shape of the penetration, avoiding wrinkles.</li> </ul>
<b>Skylights</b>	<ul style="list-style-type: none"> <li>• Curb skylights must be treated in the same fashion as curb flashings.</li> <li>• After flashing work has been completed and the coating has cured, treat deteriorated fiberglass skylight panels with United Coatings™ Acrysheen Sealer.</li> </ul>
<b>Gutters</b>	<ul style="list-style-type: none"> <li>• Trowel or brush apply FlexSeal™ Sealant to the interior or exterior gutter incorporating 12 inches (305 mm) of the recommended fabric at all gutter seams.</li> </ul>
<b>Pitch Pans</b>	<ul style="list-style-type: none"> <li>• Pitch pans must be capped with sheet metal to allow for proper sealing with United Coatings™ products.</li> <li>• Contact GAF Technical Support Services for more information.</li> </ul>
<b>Condensate Lines</b>	<ul style="list-style-type: none"> <li>• Condensate lines must be installed from HVAC units to gutters as part of the overall drainage system. The type of piping used for condensate lines may vary depending on local building codes.</li> </ul>

## ADHESION TESTING

Adhesion testing is generally performed to verify the suitability of a substrate to receive a liquid-applied coating system. It is the responsibility of the roofing contractor to determine the suitability of the substrate prior to the application of a liquid-applied coating system, as well as whether priming is required.

When adhesion tests are conducted:

- Test patches shall be labeled and photographed to document adhesion results.
- Installers may consult with GAF's Technical Support Services at 800-766-3411 concerning all adhesion test results.

GAF recommends the following test method:

Test Method: Field Peel Adhesion	
<b>Overview</b>	ASTM D903 "Peel Adhesion" is found in all roof coating standards and is especially well suited to field testing with elastomeric materials. Primers and enamels may also be evaluated by a similar test, ASTM D3359 called "Tape Adhesion." It may also be important to run the test wet to determine "wet adhesion."
<b>Preparation</b>	<ul style="list-style-type: none"> <li>• Make a mock-up of the intended coating system on the existing roof surface.</li> <li>• Duplicate any mechanical surface preparation.</li> <li>• Simulate cleaners and power washing.</li> <li>• A worn Scotch-Brite® cleaning pad makes a good power washing simulation.</li> <li>• Prime as specified.</li> <li>• Apply a layer of the specified coating to the substrate.</li> <li>• Installer should prepare no fewer than three (3) test patches for the first 100 squares and one (1) additional patch for each additional 100 squares at different locations on the roof for all questionable roof substrates to verify adhesion of the liquid-applied coating system.</li> </ul>
 <p style="text-align: center;"><b>Test Method</b></p>	<ul style="list-style-type: none"> <li>• Place about 6" (152 mm) of the pre-cut 1" (25 mm) x 12" (305 mm) fabric strip into the coating.</li> <li>• Allow the remaining 6" (152 mm) of the fabric to be available to pull on for test sample.</li> <li>• Apply another layer of coating to encapsulate the wetted section of fabric.</li> <li>• Allow to dry. This can be anywhere from 24 hours to 2 weeks.</li> <li>• In warm weather, 1 day may be sufficient.</li> <li>• In cold weather, 5 days is often required.</li> <li>• The standard practice is 1 week.</li> <li>• Soak prior to testing (best practice).</li> <li>• One hour is usually sufficient, use a wet rag and cover with a bucket lid or plastic.</li> <li>• Some coatings like a polyvinylidene difluoride (PVDF) or silicone may require longer drying times.</li> </ul>
<b>Post-Installation Method (Only to be done if standard test was omitted)</b>	<ul style="list-style-type: none"> <li>• Pre-cut 1" (25 mm) wide strips of butyl tape work faster and can be used in a post-installation inspection. A "wet adhesion" version can be accomplished by soaking the roof area first as indicated above, and then towel dry. Use butyl tape to run the pull test. The butyl tape is typically easier to use with a gauge as it will bond to itself making a perfect loop. Repair the area with similar coating after test is complete.</li> </ul>
Quantitative Evaluation	
<ul style="list-style-type: none"> <li>• Use a force gauge such as a digital fish scale or trigger pressure gauge.</li> <li>• A loop, staple or clamp may be used to hold the fabric in the gauge.</li> <li>• Pull slowly; the average value should be above 2 pounds/inch.</li> </ul>	

# **SECTION 3**

## Quick Specs

## ROOF MATE™ SPEC DIRECTORY

Spec Number	Substrate Specification	Page #
RM-1	Roof Mate™ over Metal	28
RM-2	Roof Mate™ over TPO	29
RM-3	Roof Mate™ over PVC	30
RM-4	Roof Mate™ over Hypalon®	31
RM-5	Roof Mate™ over EPDM	32
RM-6	Roof Mate™ over Smooth Asphaltic	32
RM-7	Roof Mate™ over Granulated Asphaltic	34
RM-8	Roof Mate™ over Structural Concrete	35
RM-9	Roof Mate™ over Corrugated Structural Transite Panels	36

*Quick Specs are abbreviated specifications and are not meant to replace detailed specifications. Complete 3-part CSI System Specifications are available at [www.gaf.com](http://www.gaf.com).*

# Roof Mate™ QUICK SPEC

## METAL (RM-1)

**NOTE:** The following “Quick Spec” is an abbreviated specification and is not meant to replace the detailed specification. Complete 3-part CSI System Specifications are available at [www.gaf.com](http://www.gaf.com)



### METHOD REQUIREMENTS

#### Required:

- Roof must be clean, dry and tight
- No rain, dew, fog, or freezing temperatures in forecast for 24 hours
- Adhesion test required
- Power washing required

#### Recommendations:

- Refer to Technical Data Sheet for product specific application and surface temperature restrictions.
- Rust should be removed with a wire brush prior to coating, and structural repairs should be made with like-materials as needed.

#### Installation Overview:

1. Before coating is applied, an adhesion test is required to ensure an adhesion minimum of 2.0 pounds per linear

- inch (PLI). Test patches to be applied with rates listed below.
2. Tighten/replace existing fasteners. Encapsulate with appropriate flashing material.
3. Power-wash substrate to remove contaminants that could negatively affect adhesion. Allow roof to completely dry.
4. Install crickets to divert water and complete other necessary sheet metal repairs.
5. Prime rusty areas per chart below.
6. Horizontal seams must be 3-coursed. Overlap and trapezoidal vertical seams must be treated with flashing grade only. Other vertical seams may forgo treatment **IF** the seal/tape is intact on the seam or if they are double locked. (Refer to Seam Treatment Guide for requirements)
7. Treat all roof penetrations, drains, curbs, and scuppers. (Refer to Substrate Preparation section for requirements)
8. Apply coating per the chart below:

CLEAN / PRIME		
	Product	Rate (Gal/Sq)
Cleaner	UCC Cleaner ( <i>diluted</i> )	0.5 - 0.7
Primer (rusty areas)	Acrylex 400	0.3 - 0.5
Primer (severe rust)	Lock-Down Primer	0.25 - 0.33

SEAMS & DETAILS <sup>2</sup>			
Treatment Type	Product	Total (Gal/Sq)	DFT* (mils)
3-Coursed Rates	Roof Mate™ Butter Grade & Fabric	4.0	43
Flashing Grade Only Rates	Roof Mate™ Butter Grade	2.0	19

*Note: For other product options, please refer to our Seam Treatment Guide.*

METAL								
Coverage Term	Coating				Total		Warranties/Guarantees Available	
	Product (Choose one)	1st Coat (Gal/Sq) <sup>1</sup>	2nd Coat (Gal/Sq)	3rd Coat (Gal/Sq)	Gal/Sq	DFT* (mils)	Emerald Pledge™	Diamond Pledge™
10 Year	Roof Mate™	1.00	1.50		2.50	21	Yes	Yes
	Roof Mate™ QS	1.00	1.50		2.50	21		
	Roof Mate™ HT	1.00	1.50		2.50	21		
	Roof Mate™ TCM	1.00	1.00		2.00	19		
15 Year	Roof Mate™	1.00	1.50	1.00	3.50	30	Yes	Yes
	Roof Mate™ QS	1.00	1.50	1.00	3.50	30		
	Roof Mate™ HT	1.00	1.50	1.00	3.50	29		
	Roof Mate™ TCM	1.50	1.75		3.25	30		
20 Year	Roof Mate™	1.50	1.50	1.50	4.50	38	Yes	Yes
	Roof Mate™ QS	1.50	1.50	1.50	4.50	38		
	Roof Mate™ HT	1.50	1.50	1.50	4.50	38		
	Roof Mate™ TCM	1.50	1.50	1.50	4.50	42		

\* Dry Film Thickness (DFT) is rounded to nearest mil, and is theoretical. Actual DFT will vary dependent on substrate profile, application technique and waste factor.

<sup>1</sup>RoofMate Base Coat should be used as first coat. Note: DFT for 3-coursed rates includes 6 mils for the fabric.

<sup>2</sup>Flashing rates are based on a 6" (152 mm) width, rates will double for 12" (305 mm) width.

# Roof Mate™ QUICK SPEC

## TPO (RM-2)

**NOTE:** The following “Quick Spec” is an abbreviated specification and is not meant to replace the detailed specification. Complete 3-part CSI System Specifications are available at [www.gaf.com](http://www.gaf.com)



### METHOD REQUIREMENTS

#### Required:

- Moisture survey required
- Remove and replace any wet areas
- Repair membrane with like materials
- Roof must be clean, dry and tight
- No rain, dew, fog, or freezing temperatures in forecast for 24 hours
- Adhesion test required
- Power washing required

#### Recommendations:

- Refer to Technical Data Sheet for product specific application and surface temperature restrictions.

#### Installation Overview:

1. Before coating is applied, an adhesion test is required to ensure an adhesion minimum of 2.0 pounds per linear inch (PLI). Test patches to be applied with rates listed below.
2. Power-wash substrate to remove contaminants that could negatively affect adhesion. Allow roof to completely dry.
3. Prime per chart below.
4. Treat all roof penetrations, drains, curbs, and scuppers. (Refer to Substrate Preparation section for requirements)
5. All loose seams must be 3-coursed. All other seams must be treated with flashing grade only, no fabric required. (Refer to Seam Treatment Guide for requirements)
6. Apply coating per the chart below:

CLEAN / PRIME		
	Product	Rate (Gal/Sq)
Cleaner	UCC Cleaner (diluted)	0.5 - 0.7
Primer	TPO Red Primer	0.25

SEAMS & DETAILS <sup>2</sup>			
Treatment Type	Product	Total (Gal/Sq)	DFT* (mils)
3-Coursed Rates	Roof Mate™ Butter Grade and Fabric	4.0	43
Flashing Grade Only Rates	Roof Mate™ Butter Grade	2.0	19

Note: For other product options, please refer to our Seam Treatment Guide.

TPO								
Coverage Term	Coating				Total		Warranties/Guarantees Available	
	Product (Choose one)	1st Coat (Gal/Sq) <sup>1</sup>	2nd Coat (Gal/Sq)	3rd Coat (Gal/Sq)	Gal/Sq	DFT* (mils)	Emerald Pledge™	Diamond Pledge™
10 Year	Roof Mate™	1.50	1.50		3.00	26	Yes	No
	Roof Mate™ QS	1.50	1.50		3.00	26		
	Roof Mate™ HT	1.50	1.50		3.00	25		
	Roof Mate™ TCM	1.00	1.00		2.50	23		
15 Year	Roof Mate™	1.50	1.50	1.00	4.00	34	Yes	No
	Roof Mate™ QS	1.50	1.50	1.00	4.00	34		
	Roof Mate™ HT	1.50	1.50	1.00	4.00	33		
	Roof Mate™ TCM	1.00	1.50	1.00	3.50	33		

\* Dry Film Thickness (DFT) is rounded to nearest mil, and is theoretical. Actual DFT will vary dependent on substrate profile, application technique and waste factor.

<sup>1</sup>RoofMate Base Coat should be used as first coat. Note: DFT for 3-coursed rates includes 6 mils for the fabric.

<sup>2</sup>Flashing rates are based on a 6" (152 mm) width, rates will double for 12" (305 mm) width.

# Roof Mate™ QUICK SPEC

## PVC (RM-3)

**NOTE:** The following "Quick Spec" is an abbreviated specification and is not meant to replace the detailed specification. Complete 3-part CSI System Specifications are available at [www.gaf.com](http://www.gaf.com).



### METHOD REQUIREMENTS

#### Required:

- Moisture survey required
- Remove and replace any wet areas
- Repair membrane with like materials
- Roof must be clean, dry and tight
- No rain, dew, fog, or freezing temperatures in forecast for 24 hours
- Adhesion test required
- Power washing required

#### Recommendations:

- Refer to Technical Data Sheet for product specific application and surface temperature restrictions.

#### Installation Overview:

1. Before coating is applied, an adhesion test is required to ensure an adhesion minimum of 2.0 pounds per linear inch (PLI). Test patches to be applied with rates listed below.
2. Power-wash substrate to remove contaminants that could negatively affect adhesion. Allow roof to completely dry.
3. Prime per chart below.
4. Treat all roof penetrations, drains, curbs, and scuppers. (Refer to Substrate Preparation section for requirements)
5. All loose seams must be 3-coursed. All other seams must be treated with flashing grade only, no fabric required. (Refer to Seam Treatment Guide for requirements)
6. Apply coating per the chart below:

#### CLEAN / PRIME

	Product	Rate (Gal/Sq)
Cleaner	UCC Cleaner (diluted)	0.5 - 0.7
Primer	Unisil Primer	0.33

#### SEAMS & DETAILS<sup>2</sup>

Treatment Type	Product	Total (Gal/Sq)	DFT* (mils)
3-Coursed Rates	Roof Mate™ Butter Grade and Fabric	4.0	43
Flashing Grade Only Rates	Roof Mate™ Butter Grade	2.0	19

Note: For other product options, please refer to our Seam Treatment Guide.

### PVC

Coverage Term	Coating				Total		Warranties/Guarantees Available	
	Product (Choose one)	1st Coat (Gal/Sq) <sup>1</sup>	2nd Coat (Gal/Sq)	3rd Coat (Gal/Sq)	Gal/Sq	DFT* (mils)	Emerald Pledge™	Diamond Pledge™
10 Year	Roof Mate™	1.50	1.50		3.00	26	Yes	No
	Roof Mate™ QS	1.50	1.50		3.00	26		
	Roof Mate™ HT	1.50	1.50		3.00	25		
	Roof Mate™ TCM	1.00	1.50		2.50	23		
15 Year	Roof Mate™	1.50	1.50	1.00	4.00	34	Yes	No
	Roof Mate™ QS	1.50	1.50	1.00	4.00	34		
	Roof Mate™ HT	1.50	1.50	1.00	4.00	33		
	Roof Mate™ TCM	1.00	1.50	1.00	3.50	33		

\* Dry Film Thickness (DFT) is rounded to nearest mil, and is theoretical. Actual DFT will vary dependent on substrate profile, application technique and waste.

<sup>1</sup>RoofMate Base Coat should be used as first coat. Note: DFT for 3-coursed rates includes 6 mils for the fabric.

<sup>2</sup>Flashing rates are based on a 6" (152 mm) width, rates will double for 12" (305 mm) width.

# Roof Mate™ QUICK SPEC

## Hypalon® (RM-4)

**NOTE:** The following “Quick Spec” is an abbreviated specification and is not meant to replace the detailed specification. Complete 3-part CSI System Specifications are available at [www.gaf.com](http://www.gaf.com).



### METHOD REQUIREMENTS

#### Required:

- Moisture survey required
- Remove and replace any wet areas
- Repair membrane with like materials
- Roof must be clean, dry and tight
- No rain, dew, fog, or freezing temperatures in forecast for 24 hours
- Adhesion test required
- Power washing required

#### Recommendations:

- Refer to Technical Data Sheet for product specific application and surface temperature restrictions.

#### Installation Overview:

1. Before coating is applied, an adhesion test is required to ensure an adhesion minimum of 2.0 pounds per linear inch (PLI). Test patches to be applied with rates listed below.
2. Power-wash substrate to remove contaminants that could negatively affect adhesion. Allow roof to completely dry.
3. Treat all roof penetrations, drains, curbs, and scuppers. (Refer to Substrate Preparation section for requirements)
4. All loose seams must be 3-coursed. All other seams must be treated with flashing grade only, no fabric required. (Refer to Seam Treatment Guide for requirements)
5. Apply coating per the chart below:

CLEAN / PRIME		
	Product	Rate (Gal/Sq)
Cleaner	UCC Cleaner (diluted)	0.5 - 0.7
Primer	Not required	

SEAMS & DETAILS <sup>2</sup>			
Treatment Type	Product	Total (Gal/Sq)	DFT* (mils)
3-Coursed Rates	Roof Mate™ Butter Grade and Fabric	4.0	43
Flashing Grade Only Rates	Roof Mate™ Butter Grade	2.0	19

Note: For other product options, please refer to our Seam Treatment Guide.

Hypalon®								
Coverage Term	Coating				Total		Warranties/Guarantees Available	
	Product (Choose one)	1st Coat (Gal/Sq) <sup>1</sup>	2nd Coat (Gal/Sq)	3rd Coat (Gal/Sq)	Gal/Sq	DFT* (mils)	Emerald Pledge™	Diamond Pledge™
10 Year	Roof Mate™	1.50	1.50		3.00	26	Yes	No
	Roof Mate™ QS	1.50	1.50		3.00	26		
	Roof Mate™ HT	1.50	1.50		3.00	25		
	Roof Mate™ TCM	1.00	1.50		2.50	23		
15 Year	Roof Mate™	1.50	1.50	1.00	4.00	34	Yes	No
	Roof Mate™ QS	1.50	1.50	1.00	4.00	34		
	Roof Mate™ HT	1.50	1.50	1.00	4.00	33		
	Roof Mate™ TCM	1.00	1.50	1.00	3.50	33		

\* Dry Film Thickness (DFT) is rounded to nearest mil, and is theoretical. Actual DFT will vary dependent on substrate profile, application technique and waste factor.

<sup>1</sup>RoofMate Base Coat should be used as first coat. Note: DFT for 3-coursed rates includes 6 mils for the fabric.

<sup>2</sup>Flashing rates are based on a 6" (152 mm) width, rates will double for 12" (305 mm) width.



# Roof Mate™ QUICK SPEC

## EPDM (RM-5)

**NOTE:** The following "Quick Spec" is an abbreviated specification and is not meant to replace the detailed specification. Complete 3-part CSI System Specifications are available at [www.gaf.com](http://www.gaf.com).



### METHOD REQUIREMENTS

#### Required:

- Moisture survey required
- Remove and replace any wet areas
- Repair membrane with like materials
- Roof must be clean, dry and tight
- No rain, dew, fog, or freezing temperatures in forecast for 24 hours
- Adhesion test required
- Power washing required

#### Recommendations:

- Refer to Technical Data Sheet for product specific application and surface temperature restrictions.

#### Instructions:

1. Before coating is applied, an adhesion test is required to ensure an adhesion minimum of 2.0 pounds per linear inch (PLI). Test patches to be applied with rates listed below.
2. Power-wash substrate to remove contaminants that could negatively affect adhesion. Allow roof to completely dry.
3. Prime per chart below.
4. Treat all roof penetrations, drains, curbs, and scuppers. (Refer to Substrate Preparation section for requirements)
5. All loose seams must be 3-coursed. All other seams must be treated with flashing grade only, no fabric required. (Refer to Seam Treatment Guide for requirements)
6. Apply coating per the chart below:

#### CLEAN / PRIME

	Product	Rate (Gal/Sq)
Cleaner	UCC Cleaner (diluted)	0.5 - 0.7
Primer	CleanAct Rinsable Primer	0.20

#### SEAMS & DETAILS<sup>2</sup>

Treatment Type	Product	Total (Gal/Sq)	DFT* (mils)
3-Coursed Rates	Roof Mate™ Butter Grade and Fabric	4.0	43
Flashing Grade Only Rates	Roof Mate™ Butter Grade	2.0	19

Note: For other product options, please refer to our Seam Treatment Guide.

### EPDM

Coverage Term	Coating				Total		Warranties/Guarantees Available	
	Product (Choose one)	1st Coat (Gal/Sq)	2nd Coat (Gal/Sq)	3rd Coat (Gal/Sq)	Gal/Sq	DFT* (mils)	Emerald Pledge™	Diamond Pledge™
10 Year	Roof Mate™	1.50	1.50		3.00	26	Yes	No
	Roof Mate™ QS	1.50	1.50		3.00	26		
	Roof Mate™ HT	1.50	1.50		3.00	25		
	Roof Mate™ TCM	1.00	1.50		2.50	23		
15 Year	Roof Mate™	1.50	1.50	1.00	4.00	34	Yes	No
	Roof Mate™ QS	1.50	1.50	1.00	4.00	34		
	Roof Mate™ HT	1.50	1.50	1.00	4.00	33		
	Roof Mate™ TCM	1.00	1.50	1.00	3.50	33		

\* Dry Film Thickness (DFT) is rounded to nearest mil, and is theoretical. Actual DFT will vary dependent on substrate profile, application technique and waste factor.

Note: DFT for 3-coursed rates includes 6 mils for the fabric.

<sup>2</sup>Flashing rates are based on a 6" (152 mm) width, rates will double for 12" (305 mm) width.

# Roof Mate™ QUICK SPEC

## SMOOTH ASPHALTIC (RM-6)

**NOTE:** The following “Quick Spec” is an abbreviated specification and is not meant to replace the detailed specification. Complete 3-part CSI System Specifications are available at [www.gaf.com](http://www.gaf.com).



### METHOD REQUIREMENTS

#### Required:

- Moisture survey required
- Remove and replace any wet areas
- Repair membrane with like materials
- Roof must be clean, dry and tight
- No rain, dew, fog, or freezing temperatures in forecast for 24 hours
- Adhesion test required
- Power washing required

#### Restrictions:

Do not apply over gravel surfaced substrates.

#### Recommendations:

- Refer to Technical Data Sheet for product specific application and surface temperature restrictions.
- New membranes should be aged at least 30 days; 90 days is ideal.

#### Installation Overview:

1. Before coating is applied, an adhesion test is required to ensure an adhesion minimum of 2.0 pounds per linear inch (PLI). Test patches to be applied with rates listed below.
2. Power-wash substrate to remove contaminants that could negatively affect adhesion. Allow roof to completely dry.
3. Prime per chart below.
4. Treat “alligatored” areas, surface cracks, roof penetrations, drains, curbs and scuppers. (Refer to Substrate Preparation section for requirements)
5. All loose seams must be 3-coursed. All other seams must be treated with flashing grade only, no fabric required. (Refer to Seam Treatment Guide for requirements)
6. Apply coating per the chart below:

CLEAN / PRIME <sup>+</sup>		
	Product	Rate (Gal/Sq)
Cleaner	UCC Cleaner (diluted)	0.5 - 0.7
Primer <sup>+</sup>	UniBase Primer	0.5-1.0

<sup>+</sup>When Roof Mate™ Base Coat or Roof Mate™ MB Plus are used, primer is not required.

SEAMS & DETAILS <sup>2</sup>			
Treatment Type	Product	Total (Gal/Sq)	DFT* (mils)
3-Coursed Rates	Roof Mate™ Butter Grade and Fabric	4.0	43
Flashing Grade Only Rates	Roof Mate™ Butter Grade	2.0	19

Note: For other product options, please refer to our Seam Treatment Guide.

SMOOTH ASPHALTIC								
Coverage Term	Coating				Total		Warranties/Guarantees Available	
	Product (Choose one)	1st Coat (Gal/Sq) <sup>1</sup>	2nd Coat (Gal/Sq)	3rd Coat (Gal/Sq)	Gal/Sq	DFT* (mils)	Emerald Pledge™	Diamond Pledge™
10 Year	Roof Mate™	1.50	1.50		3.00	25	Yes	No
	Roof Mate™ QS	1.50	1.50		3.00	25		
	Roof Mate™ HT	1.50	1.50		3.00	25		
	Roof Mate™ MB Plus	1.50	1.50		3.00	26		
15 Year	Roof Mate™	1.50	1.50	1.50	4.50	38	Yes	No
	Roof Mate™ QS	1.50	1.50	1.50	4.50	38		
	Roof Mate™ HT	1.50	1.50	1.50	4.50	38		
	Roof Mate™ MB Plus	1.50	1.50	1.00	4.00	35		

\* Dry Film Thickness (DFT) is rounded to nearest mil, and is theoretical. Actual DFT will vary dependent on substrate profile, application technique and waste factor.

<sup>1</sup>RoofMate Base Coat should be used as first coat. Note: DFT for 3-coursed rates includes 6 mils for the fabric.

<sup>2</sup>Flashing rates are based on a 6" (152 mm) width, rates will double for 12" (305 mm) width.

# Roof Mate™ QUICK SPEC

## GRANULATED ASPHALTIC (RM-7)

**NOTE:** The following "Quick Spec" is an abbreviated specification and is not meant to replace the detailed specification. Complete 3-part CSI System Specifications are available at [www.gaf.com](http://www.gaf.com).



### METHOD REQUIREMENTS

#### Required:

- Moisture survey required
- Remove and replace any wet areas
- Repair membrane with like materials
- Roof must be clean, dry and tight
- No rain, dew, fog, or freezing temperatures in forecast for 24 hours
- Adhesion test required
- Power washing required

#### Restrictions:

Do not apply over gravel surfaced substrates.

#### Recommendations:

- Refer to Technical Data Sheet for product specific application and surface temperature restrictions.
- New membranes should be aged at least 30 days; 90 days is ideal.

#### Installation Overview:

1. Before coating is applied, an adhesion test is required to ensure an adhesion minimum of 2.0 pounds per linear inch (PLI). Test patches to be applied with rates listed below.
2. Power-wash substrate to remove contaminants that could negatively affect adhesion. Allow roof to completely dry.
3. Prime per chart below.
4. Treat "alligatored" areas, surface cracks, roof penetrations, drains, curbs and scuppers. (Refer to Substrate Preparation section for requirements)
5. All loose seams must be 3-coursed. All other seams must be treated with flashing grade only, no fabric required. (Refer to Seam Treatment Guide for requirements)
6. Apply coating per the chart below:

#### CLEAN / PRIME<sup>+</sup>

	Product	Rate (Gal/Sq)
Cleaner	UCC Cleaner (diluted)	0.5 - 0.7
Primer <sup>+</sup>	Unibase Primer	0.5-1.0

<sup>+</sup>When Roof Mate™ Base Coat or Roof Mate™ MB Plus are used, primer is not required.

#### SEAMS & DETAILS<sup>2</sup>

Treatment Type	Product	Total (Gal/Sq)	DFT* (mils)
3-Coursed Rates	Roof Mate™ Butter Grade and Fabric	4.0	43
Flashing Grade Only Rates	Roof Mate™ Butter Grade	2.0	19

Note: For other product options, please refer to our Seam Treatment Guide.

### GRANULATED ASPHALTIC

Coverage Term	Coating				Total		Warranties/Guarantees Available	
	Product (Choose one)	1st Coat (Gal/Sq) <sup>1</sup>	2nd Coat (Gal/Sq)	3rd Coat (Gal/Sq)	Gal/Sq	DFT* (mils)	Emerald Pledge™	Diamond Pledge™
10 Year	Roof Mate™	1.50	1.50		3.00	25	Yes	No
	Roof Mate™ QS	1.50	1.50		3.00	25		
	Roof Mate™ HT	1.50	1.50		3.00	25		
	Roof Mate™ MB Plus	1.50	1.50		3.00	26		
15 Year	Roof Mate™	1.50	1.50	1.50	4.50	38	Yes	No
	Roof Mate™ QS	1.50	1.50	1.50	4.50	38		
	Roof Mate™ HT	1.50	1.50	1.50	4.50	38		
	Roof Mate™ MB Plus	1.50	1.50	1.00	4.00	35		

\* Dry Film Thickness (DFT) is rounded to nearest mil, and is theoretical. Actual DFT will vary dependent on substrate profile, application technique and waste factor.

<sup>1</sup>RoofMate Base Coat should be used as first coat. Note: DFT for 3-coursed rates includes 6 mils for the fabric.

<sup>2</sup>Flashing rates are based on a 6" (152 mm) width, rates will double for 12" (305 mm) width.

# Roof Mate™ QUICK SPEC

## STRUCTURAL CONCRETE (RM-8)

**NOTE:** The following “Quick Spec” is an abbreviated specification and is not meant to replace the detailed specification. Complete 3-part CSI System Specifications are available at [www.gaf.com](http://www.gaf.com).



### METHOD REQUIREMENTS

#### Required:

- Moisture survey required (Must contain less than 8% moisture)
- Repair deteriorated sections with like materials. Allow repairs to cure properly.
- Roof must be clean, dry and tight
- No rain, dew, fog, or freezing temperatures in forecast for 24 hours
- Adhesion test required
- Power washing required
- Concrete must be fully cured

#### Recommendations:

- Refer to Technical Data Sheet for product specific application and surface temperature restrictions.

#### Installation Overview:

1. Before coating is applied, an adhesion test is required to ensure an adhesion minimum of 2.0 pounds per linear inch (PLI). Test patches to be applied with rates listed below.
2. Power-wash substrate to remove contaminants that could negatively affect adhesion. Allow roof to completely dry.
3. Prime per chart below.
4. Treat all roof penetrations, drains, curbs, and scuppers. (Refer to Substrate Preparation section for requirements)
5. Treat structural joints with backer rod and compatible sealant prior to seam treatment. (Refer to Seam Treatment Guide for requirements)
6. Control joints in excess of 1/16" (1.6mm) shall also be caulked with a compatible caulk.
7. Apply coating per the chart below:

#### CLEAN / PRIME

	Product	Rate (Gal/Sq)
Cleaner	UCC Cleaner (diluted)	0.5 - 0.7
Primer	Epoxy Primer	0.3-0.4

#### SEAMS & DETAILS<sup>2</sup>

Treatment Type	Product	Total (Gal/Sq)	DFT* (mils)
3-Coursed Rates	Roof Mate™ Butter Grade and Fabric	4.0	43
Flashing Grade Only Rates	Roof Mate™ Butter Grade	2.0	19

Note: For other product options, please refer to our Seam Treatment Guide.

### STRUCTURAL CONCRETE

Coverage Term	Coating				Total		Warranties/Guarantees Available	
	Product (Choose one)	1st Coat (Gal/Sq) <sup>1</sup>	2nd Coat (Gal/Sq)	3rd Coat (Gal/Sq)	Gal/Sq	DFT* (mils)	Emerald Pledge™	Diamond Pledge™
10 Year	Roof Mate™	1.50	1.50		3.00	26	Yes	No
	Roof Mate™ QS	1.50	1.50		3.00	26		
	Roof Mate™ HT	1.50	1.50		3.00	25		
	Roof Mate™ TCM	1.50	1.50		3.00	28		
15 Year	Roof Mate™	1.50	1.50	1.00	4.00	34	Yes	No
	Roof Mate™ QS	1.50	1.50	1.00	4.00	34		
	Roof Mate™ HT	1.50	1.50	1.00	4.00	33		
	Roof Mate™ TCM	1.50	1.50	1.00	4.00	37		

\* Dry Film Thickness (DFT) is rounded to nearest mil, and is theoretical. Actual DFT will vary dependent on substrate profile, application technique and waste factor.

<sup>1</sup>RoofMate Base Coat should be used as first coat. Note: DFT for 3-coursed rates includes 6 mils for the fabric.

<sup>2</sup>Flashing rates are based on a 6" (152 mm) width, rates will double for 12" (305 mm) width.

# Roof Mate™ QUICK SPEC

## CORRUGATED STRUCTURAL TRANSITE PANELS (RM-9)

**NOTE:** The following "Quick Spec" is an abbreviated specification and is not meant to replace the detailed specification. Complete 3-part CSI System Specifications are available at [www.gaf.com](http://www.gaf.com).



### METHOD REQUIREMENTS

#### Required:

- Moisture survey required
- Remove and replace any wet areas
- Repair membrane with like materials
- Roof must be clean, dry and tight
- No rain, dew, fog, or freezing temperatures in forecast for 24 hours
- Adhesion test required
- Power washing required

#### Recommendations:

- Refer to Technical Data Sheet for product specific application and surface temperature restrictions.

#### Installation Overview:

1. Before coating is applied, an adhesion test is required to ensure an adhesion minimum of 2.0 pounds per linear inch (PLI). Test patches to be applied with rates listed below.
2. Power-wash substrate to remove contaminants that could negatively affect adhesion. Allow roof to completely dry.
3. Tighten/replace existing fasteners. Encapsulate with appropriate flashing material.
4. Prime per chart below.
5. Treat all roof penetrations, drains, curbs, and scuppers. (Refer to Substrate Preparation section for requirements)
6. Treat transite gaps in excess of 1/16" with compatible caulk prior to seam treatment. (Refer to Substrate Preparation Seam Treatment Guide for requirements)
7. Apply coating per the chart below:

#### CLEAN / PRIME

	Product	Rate (Gal/Sq)
Cleaner	UCC Cleaner (diluted)	0.5 - 0.7
Primer	Epoxy Primer	0.3-0.4

#### SEAMS & DETAILS<sup>2</sup>

Treatment Type	Product	Total (Gal/Sq)	DFT* (mils)
3-Coursed Rates	Roof Mate™ Butter Grade and Fabric	4.0	43
Flashing Grade Only Rates	Roof Mate™ Butter Grade	2.0	19

Note: For other product options, please refer to our Seam Treatment Guide.

### CORRUGATED STRUCTURAL TRANSITE PANELS

Coverage Term	Coating				Total		Warranties/Guarantees Available	
	Product (Choose one)	1st Coat (Gal/Sq) <sup>1</sup>	2nd Coat (Gal/Sq)	3rd Coat (Gal/Sq)	Gal/Sq	DFT* (mils)	Emerald Pledge™	Diamond Pledge™
10 Year	Roof Mate™	1.50	1.50		3.00	26	Yes	No
	Roof Mate™ QS	1.50	1.50		3.00	26		
	Roof Mate™ HT	1.50	1.50		3.00	25		
	Roof Mate™ TCM	1.50	1.50		3.00	28		
15 Year	Roof Mate™	1.50	1.50	1.00	4.00	34	Yes	No
	Roof Mate™ QS	1.50	1.50	1.00	4.00	34		
	Roof Mate™ HT	1.50	1.50	1.00	4.00	33		
	Roof Mate™ TCM	1.50	1.50	1.00	4.00	37		

\* Dry Film Thickness (DFT) is rounded to nearest mil, and is theoretical. Actual DFT will vary dependent on substrate profile, application technique and waste factor.

<sup>1</sup>RoofMate Base Coat should be used as first coat. Note: DFT for 3-coursed rates includes 6 mils for the fabric.

<sup>2</sup>Flashing rates are based on a 6" (152 mm) width, rates will double for 12" (305 mm) width.

**IMPORTANT NOTE:** Corrugated structural transite panels may contain asbestos. Follow all applicable local, state and federal regulations concerning asbestos. Under no circumstances does GAF have any liability for any damages, costs or expenses arising out of or associated with the pre-existing presence of asbestos-containing materials or any other allegedly hazardous substances or materials upon the roof to which the new GAF roofing materials are being applied.

## UNISIL II QUICK SPEC DIRECTORY

Spec Number	Substrate Specification	Page #
UN-1	Unisil II over Metal	38
UN-2	Unisil II over PVC	39
UN-3	Unisil II Hypalon®	40
UN-4	Unisil II over EPDM	41
UN-5	Unisil II Smooth Asphaltic	42
UN-6	Unisil II Granulated Asphaltic	43
UN-7	Unisil II over Structural Concrete	44
UN-8	Unisil II over Corrugated Structural Transite Panels	45
UN-9	Unisil II over Spray Polyurethane Foam	46
UN-10	Unisil II over Aged TPO	47

*Quick Specs are abbreviated specifications and are not meant to replace detailed specifications. Complete 3-part CSI System Specifications are available at [www.gaf.com](http://www.gaf.com).*

# UNISIL II QUICK SPEC

## METAL (UN-1)

**NOTE:** The following “Quick Spec” is an abbreviated specification and is not meant to replace the detailed specification. Complete 3-part CSI System Specifications are available at [www.gaf.com](http://www.gaf.com).



### METHOD REQUIREMENTS

#### Required:

- Roof must be clean, dry and tight
- No rain, dew, fog, or freezing temperatures in forecast for 24 hours
- Adhesion test required
- Power washing required

#### Recommendations:

- Refer to Technical Data Sheet for product specific application and surface temperature restrictions.
- Rust should be removed with a wire brush prior to coating, and structural repairs should be made with like-materials as needed.

#### Installation Overview:

1. Before coating is applied, an adhesion test is required to ensure an adhesion minimum of 2.0

2. Tighten/replace existing fasteners. Encapsulate with appropriate flashing material.
3. Power-wash substrate to remove contaminants that could negatively affect adhesion. Allow roof to completely dry.
4. Install crickets to divert water and complete any other necessary sheet metal repairs.
5. Treat all roof penetrations, drains, curbs, and scuppers. (Refer to Substrate Preparation section for requirements)
6. Horizontal seams must be 3-coursed. Overlap and trapezoidal vertical seams may forgo treatment **IF** the seal/tape is intact on the seam or if they are double locked. (Refer to Seam Treatment Guide for requirements)
7. Apply coating per the chart below:

### CLEAN / PRIME

	Product	Rate (Gal/Sq)
Cleaner	UCC Cleaner (diluted)	0.5 - 0.7
Primer	Not required	

### SEAMS & DETAILS<sup>1</sup>

Treatment Type	Product	Total (Gal/Sq)	DFT* (mils)
3-Coursed Rates	Unisil Silicone Flashing and Fabric	2.50	44
Flashing Grade Only Rates	Unisil Silicone Flashing	1.25	19

*Note: For other product options, please refer to our Seam Treatment Guide.*

### METAL

Coverage Term	Coating			Total		Warranties/Guarantees Available	
	1st Coat (Gal/Sq)	2nd Coat (Gal/Sq)	3rd Coat (Gal/Sq)	Gal/Sq	DFT* (mils)	Emerald Pledge™	Diamond Pledge™
10 Year	1.00	1.00		2.00	22	Yes	Yes
15 Year	1.25	1.50		2.75	30	Yes	Yes
20 Year	1.00	1.50	1.00	3.50	38	Yes	Yes

\* Dry Film Thickness (DFT) is rounded to nearest mil, and is theoretical. Actual DFT will vary dependent on substrate profile, application technique and waste factor.

Note: DFT for 3-coursed rates includes 6 mils for the fabric.

<sup>1</sup>Flashing rates are based on a 6" (152 mm) width, rates will double for 12" (305 mm) width.

# UNISIL II QUICK SPEC

## PVC (UN-2)

**NOTE:** The following "Quick Spec" is an abbreviated specification and is not meant to replace the detailed specification. Complete 3-part CSI System Specifications are available at [www.gaf.com](http://www.gaf.com).



### METHOD REQUIREMENTS

#### Required:

- Moisture survey required
- Remove and replace any wet areas
- Repair membrane with like materials
- Roof must be clean, dry and tight
- No rain, dew, fog, or freezing temperatures in forecast for 24 hours
- Adhesion test required
- Power washing required

#### Recommendations:

- Refer to Technical Data Sheet for product specific application and surface temperature restrictions.

#### Installation Overview:

1. Before coating is applied, an adhesion test is required to ensure an adhesion minimum of 2.0 pounds per linear inch (PLI). Test patches to be applied with rates listed below.
2. Power-wash substrate to remove contaminants that could negatively affect adhesion. Allow roof to completely dry.
3. Prime per chart below.
4. Treat all roof penetrations, drains, curbs, and scuppers. (Refer to Substrate Preparation section for requirements)
5. All loose seams must be 3-coursed. All other seams must be treated with flashing grade only, no fabric required. (Refer to Seam Treatment Guide for requirements)
6. Apply coating per the chart below:

#### CLEAN / PRIME

	Product	Rate (Gal/Sq)
Cleaner	UCC Cleaner ( <i>diluted</i> )	0.5 - 0.7
Primer	Unisil Primer	0.33

#### SEAMS & DETAILS<sup>1</sup>

Treatment Type	Product	Total (Gal/Sq)	DFT* (mils)
3-Coursed Rates	Unisil Silicone Flashing and Fabric	2.50	44
Flashing Grade Only Rates	Unisil Silicone Flashing	1.25	19

*Note: For other product options, please refer to our Seam Treatment Guide.*

#### PVC

Coverage Term	Coating			Total		Warranties/Guarantees Available	
	1st Coat (Gal/Sq)	2nd Coat (Gal/Sq)	3rd Coat (Gal/Sq)	Gal/Sq	DFT* (mils)	Emerald Pledge™	Diamond Pledge™
10 Year	1.00	1.00		2.00	22	Yes	No
15 Year	1.25	1.50		2.75	30	Yes	No
20 Year	1.00	1.50	1.00	3.50	38	Yes	No

\* Dry Film Thickness (DFT) is rounded to nearest mil, and is theoretical. Actual DFT will vary dependent on substrate profile, application technique and waste factor.

Note: DFT for 3-coursed rates includes 6 mils for the fabric.

<sup>1</sup>Flashing rates are based on a 6" (152 mm) width, rates will double for 12" (305 mm) width.



# UNISIL II QUICK SPEC

## Hypalon® (UN-3)

**NOTE:** The following "Quick Spec" is an abbreviated specification and is not meant to replace the detailed specification. Complete 3-part CSI System Specifications are available at [www.gaf.com](http://www.gaf.com).



### METHOD REQUIREMENTS

#### Required:

- Moisture survey required
- Remove and replace any wet areas
- Repair membrane with like materials
- Roof must be clean, dry and tight
- No rain, dew, fog, or freezing temperatures in forecast for 24 hours
- Adhesion test required
- Power washing required

#### Recommendations:

- Refer to Technical Data Sheet for product specific application and surface temperature restrictions.

#### Installation Overview:

1. Before coating is applied, an adhesion test is required to ensure an adhesion minimum of 2.0 pounds per linear inch (PLI). Test patches to be applied with rates listed below.
2. Power-wash substrate to remove contaminants that could negatively affect adhesion. Allow roof to completely dry.
3. Treat all roof penetrations, drains, curbs, and scuppers. (Refer to Substrate Preparation section for requirements)
4. All loose seams must be 3-coursed. All other seams must be treated with flashing grade only, no fabric required. (Refer to Seam Treatment Guide for requirements)
5. Apply coating per the chart below:

#### CLEAN / PRIME

	Product	Rate (Gal/Sq)
Cleaner	UCC Cleaner ( <i>diluted</i> )	0.5 - 0.7
Primer	Not required	

#### SEAMS & DETAILS<sup>1</sup>

Treatment Type	Product	Total (Gal/Sq)	DFT* (mils)
3-Coursed Rates	Unisil Silicone Flashing and Fabric	2.50	44
Flashing Grade Only Rates	Unisil Silicone Flashing	1.25	19

*Note: For other product options, please refer to our Seam Treatment Guide.*

#### Hypalon®

Coverage Term	Coating			Total		Warranties/Guarantees Available	
	1st Coat (Gal/Sq)	2nd Coat (Gal/Sq)	3rd Coat (Gal/Sq)	Gal/Sq	DFT* (mils)	Emerald Pledge™	Diamond Pledge™
10 Year	1.00	1.00		2.00	22	Yes	No
15 Year	1.25	1.50		2.75	30	Yes	No
20 Year	1.00	1.50	1.00	3.50	38	Yes	No

\* Dry Film Thickness (DFT) is rounded to nearest mil, and is theoretical. Actual DFT will vary dependent on substrate profile, application technique and waste factor.

Note: DFT for 3-coursed rates includes 6 mils for the fabric.

<sup>1</sup>Flashing rates are based on a 6" (152 mm) width, rates will double for 12" (305 mm) width.

# UNISIL II QUICK SPEC

## EPDM (UN-4)

**NOTE:** The following "Quick Spec" is an abbreviated specification and is not meant to replace the detailed specification. Complete 3-part CSI System Specifications are available at [www.gaf.com](http://www.gaf.com).



### METHOD REQUIREMENTS

#### Required:

- Moisture survey required
- Remove and replace any wet areas
- Repair membrane with like materials
- Roof must be clean, dry and tight
- No rain, dew, fog, or freezing temperatures in forecast for 24 hours
- Adhesion test required
- Power washing required

#### Recommendations:

- Refer to Technical Data Sheet for product specific application and surface temperature restrictions.

#### Installation Overview:

1. Before coating is applied, an adhesion test is required to ensure an adhesion minimum of 2.0 pounds per linear inch (PLI). Test patches to be applied with rates listed below.
2. Power-wash substrate to remove contaminants that could negatively affect adhesion. Allow roof to completely dry.
3. Prime per chart below.
4. Treat all roof penetrations, drains, curbs, and scuppers. (Refer to Substrate Preparation section for requirements)
5. All loose seams must be 3-coursed. All other seams must be treated with flashing grade only, no fabric required. (Refer to Seam Treatment Guide for requirements)
6. Apply coating per the chart below:

#### CLEAN / PRIME

	Product	Rate (Gal/Sq)
Cleaner	UCC Cleaner ( <i>diluted</i> )	0.5 - 0.7
Primer	CleanAct Rinsable Primer	0.20

#### SEAMS & DETAILS<sup>1</sup>

Treatment Type	Product	Total (Gal/Sq)	DFT* (mils)
3-Coursed Rates	Unisil Silicone Flashing and Fabric	2.50	44
Flashing Grade Only Rates	Unisil Silicone Flashing	1.25	19

*Note: For other product options, please refer to our Seam Treatment Guide.*

#### EPDM

Coverage Term	Coating			Total		Warranties/Guarantees Available	
	1st Coat (Gal/Sq)	2nd Coat (Gal/Sq)	3rd Coat (Gal/Sq)	Gal/Sq	DFT* (mils)	Emerald Pledge™	Diamond Pledge™
10 Year	1.00	1.00		2.00	22	Yes	No
15 Year	1.25	1.50		2.75	30	Yes	No
20 Year	1.00	1.50	1.00	3.50	38	Yes	No

\* Dry Film Thickness (DFT) is rounded to nearest mil, and is theoretical. Actual DFT will vary dependent on substrate profile, application technique and waste factor.

Note: DFT for 3-coursed rates includes 6 mils for the fabric.

<sup>1</sup>Flashing rates are based on a 6" (152 mm) width, rates will double for 12" (305 mm) width.

# UNISIL II QUICK SPEC

## SMOOTH ASPHALTIC (UN-5)

**NOTE:** The following "Quick Spec" is an abbreviated specification and is not meant to replace the detailed specification. Complete 3-part CSI System Specifications are available at [www.gaf.com](http://www.gaf.com).



### METHOD REQUIREMENTS

#### Required:

- Moisture survey required
- Remove and replace any wet areas
- Repair membrane with like materials
- Roof must be clean, dry and tight
- No rain, dew, fog, or freezing temperatures in forecast for 24 hours
- Adhesion test required
- Power washing required

#### Restrictions:

Do not apply over gravel surfaced substrates.

#### Recommendations:

- Refer to Technical Data Sheet for product specific application and surface temperature restrictions.
- New membranes should be aged at least 30 days; 90 days ideal.

#### Installation Overview:

1. Before coating is applied, an adhesion test is required to ensure an adhesion minimum of 2.0 pounds per linear inch (PLI). Test patches to be applied with rates listed below.
2. Power-wash substrate to remove contaminants that could negatively affect adhesion. Allow roof to completely dry.
3. Prime per chart below.
4. All loose seams must be 3-coursed. All other seams must be treated with flashing grade only, no fabric required. (Refer to Substrate Preparation section for requirements)
5. Treat "alligatored" areas, surface cracks, roof penetrations, drains, curbs and scuppers. (Refer to Substrate Preparation section for requirements)
6. Apply coating per the chart below:

### CLEAN / PRIME

	Product	Rate (Gal/Sq)
Cleaner	UCC Cleaner (diluted)	0.5 - 0.7
Primer <sup>+</sup>	Unisil Primer	.67-1.0

<sup>+</sup>When Roof Mate™ Base Coat or Roof Mate™ MB Plus are used, primer is not required.

### SEAMS & DETAILS<sup>1</sup>

Treatment Type	Product	Total (Gal/Sq)	DFT* (mils)
3-Coursed Rates	Unisil Silicone Flashing and Fabric	2.50	44
Flashing Grade Only Rates	Unisil Silicone Flashing	1.25	19

*Note: For other product options, please refer to our Seam Treatment Guide.*

### SMOOTH ASPHALTIC

Coverage Term	Coating			Total		Warranties/Guarantees Available	
	1st Coat (Gal/Sq)	2nd Coat (Gal/Sq)	3rd Coat (Gal/Sq)	Gal/Sq	DFT* (mils)	Emerald Pledge™	Diamond Pledge™
10 Year	1.50	1.00		2.50	27	Yes	No
15 Year	1.25	1.00	1.00	3.25	35	Yes	No
20 Year	1.50	1.50	1.00	4.00	44	Yes	No

\* Dry Film Thickness (DFT) is rounded to nearest mil, and is theoretical. Actual DFT will vary dependent on substrate profile, application technique and waste factor.

Note: DFT for 3-coursed rates includes 6 mils for the fabric.

<sup>1</sup>Flashing rates are based on a 6" (152 mm) width, rates will double for 12" (305 mm) width.

# UNISIL II QUICK SPEC

## GRANULATED ASPHALTIC (UN-6)

**NOTE:** The following "Quick Spec" is an abbreviated specification and is not meant to replace the detailed specification. Complete 3-part CSI System Specifications are available at [www.gaf.com](http://www.gaf.com).



### METHOD REQUIREMENTS

#### Required:

- Moisture survey required
- Remove and replace any wet areas
- Repair membrane with like materials
- Roof must be clean, dry and tight
- No rain, dew, fog, or freezing temperatures in forecast for 24 hours
- Adhesion test required
- Power washing required

#### Restrictions:

Do not apply over gravel surfaced substrates.

#### Recommendations:

- Refer to Technical Data Sheet for product specific application and surface temperature restrictions.
- New membranes should be aged at least 30 days; 90 days is ideal.

#### Installation Overview:

1. Before coating is applied, an adhesion test is required to ensure an adhesion minimum of 2.0 pounds per linear inch (PLI). Test patches to be applied with rates listed below.
2. Power-wash substrate to remove contaminants that could negatively affect adhesion. Allow roof to completely dry.
3. Prime per chart below.
4. All loose seams must be 3-coursed. All other seams must be treated with flashing grade only, no fabric required. (Refer to Substrate Preparation section for requirements)
5. Treat "alligatored" areas, surface cracks, roof penetrations, drains, curbs and scuppers. (Refer to Substrate Preparation section for requirements)
6. Apply coating per the chart below:

### SURFACE PREP

	Product	Rate (Gal/Sq)
Cleaner	UCC Cleaner (diluted)	0.5 - 0.7
Primer*	Unisil Primer	1.0-1.3

\*When Roof Mate™ Base Coat or Roof Mate™ MB Plus are used, primer is not required.

### SEAMS & DETAILS<sup>1</sup>

Treatment Type	Product	Total (Gal/Sq)	DFT* (mils)
3-Coursed Rates	Unisil Silicone Flashing and Fabric	2.50	44
Flashing Grade Only Rates	Unisil Silicone Flashing	1.25	19

Note: For other product options, please refer to our Seam Treatment Guide.

### GRANULATED ASPHALTIC

Coverage Term	Coating			Total		Warranties/Guarantees Available	
	1st Coat (Gal/Sq)	2nd Coat (Gal/Sq)	3rd Coat (Gal/Sq)	Gal/Sq	DFT* (mils)	Emerald Pledge™	Diamond Pledge™
10 Year	1.50	1.00		2.50	27	Yes	No
15 Year	1.25	1.00	1.00	3.25	35	Yes	No
20 Year	1.50	1.50	1.00	4.00	44	Yes	No

\* Dry Film Thickness (DFT) is rounded to nearest mil, and is theoretical. Actual DFT will vary dependent on substrate profile, application technique and waste factor.

Note: DFT for 3-coursed rates includes 6 mils for the fabric.

<sup>1</sup>Flashing rates are based on a 6" (152 mm) width, rates will double for 12" (305 mm) width.

# UNISIL II QUICK SPEC

## STRUCTURAL CONCRETE (UN-7)

**NOTE:** The following “Quick Spec” is an abbreviated specification and is not meant to replace the detailed specification. Complete 3-part CSI System Specifications are available at [www.gaf.com](http://www.gaf.com).



### METHOD REQUIREMENTS

#### Required:

- Moisture survey required (Must contain less than 8% moisture)
- Repair deteriorated sections with like materials. Allow repairs to cure properly
- Roof must be clean, dry and tight
- No rain, dew, fog, or freezing temperatures in forecast for 24 hours
- Adhesion test required
- Power washing required
- Concrete must be fully cured

#### Recommendations:

- Refer to Technical Data Sheet for product specific application and surface temperature restrictions.

#### Installation Overview:

1. Before coating is applied, an adhesion test is required to ensure an adhesion minimum of 2.0 pounds per linear inch (PLI). Test patches to be applied with rates listed below.
2. Power-wash substrate to remove contaminants that could negatively affect adhesion. Allow roof to completely dry.
3. Prime per chart below.
4. Treat all roof penetrations, drains, curbs, and scuppers. (Refer to Substrate Preparation section for requirements)
5. Treat structural joints with backer rod and compatible sealant prior to seam treatment. (Refer to Seam Treatment Guide for requirements)
6. Control joints in excess of 1/16” (1.6 mm) shall be caulked with compatible caulk.
7. Apply coating per the chart below:

### CLEAN / PRIME

	Product	Rate (Gal/Sq)
Cleaner	UCC Cleaner ( <i>diluted</i> )	0.5 - 0.7
Primer	Unisil Primer	0.50 - 0.67

### SEAMS & DETAILS<sup>1</sup>

Treatment Type	Product	Total (Gal/Sq)	DFT* (mils)
3-Coursed Rates	Unisil Silicone Flashing and Fabric	2.50	44
Flashing Grade Only Rates	Unisil Silicone Flashing	1.25	19

*Note: For other product options, please refer to our Seam Treatment Guide.*

### STRUCTURAL CONCRETE

Coverage Term	Coating			Total		Warranties/Guarantees Available	
	1st Coat (Gal/Sq)	2nd Coat (Gal/Sq)	3rd Coat (Gal/Sq)	Gal/Sq	DFT* (mils)	Emerald Pledge™	Diamond Pledge™
10 Year	1.50	1.00		2.50	27	Yes	No
15 Year	1.25	1.00	1.00	3.25	35	Yes	No
20 Year	1.50	1.50	1.00	4.00	44	Yes	No

*\* Dry Film Thickness (DFT) is rounded to nearest mil, and is theoretical. Actual DFT will vary dependent on substrate profile, application technique and waste factor.*

*Note: DFT for 3-coursed rates includes 6 mils for the fabric.*

*<sup>1</sup>Flashing rates are based on a 6” (152 mm) width, rates will double for 12” (305 mm) width.*

# UNISIL II QUICK SPEC

## CORRUGATED STRUCTURAL TRANSITE PANELS (UN-8)

**NOTE:** The following "Quick Spec" is an abbreviated specification and is not meant to replace the detailed specification. Complete 3-part CSI System Specifications are available at [www.gaf.com](http://www.gaf.com).



### METHOD REQUIREMENTS

#### Required:

- Moisture survey required
- Remove and replace any wet areas
- Repair membrane with like materials
- Roof must be clean, dry and tight
- No rain, dew, fog, or freezing temperatures in forecast for 24 hours
- Adhesion test required
- Power washing required

#### Recommendations:

- Refer to Technical Data Sheet for product specific application and surface temperature restrictions.

#### Installation Overview:

1. Before coating is applied, an adhesion test is required to ensure an adhesion minimum of 2.0 pounds per linear inch (PLI). Test patches to be applied with rates listed below.
2. Power-wash substrate to remove contaminants that could negatively affect adhesion. Allow roof to completely dry.
3. Tighten/replace existing fasteners. Encapsulate with appropriate flashing material.
4. Prime per chart below.
5. Treat all roof penetrations, drains, curbs, and scuppers. (Refer to Substrate Preparation section for requirements)
6. Treat transite gaps in excess of 1/16" with compatible caulk prior to seam treatment. (Refer to Substrate Preparation Seam Treatment Guide for requirements)
7. Apply coating per the chart below:

#### CLEAN / PRIME

	Product	Rate (Gal/Sq)
Cleaner	UCC Cleaner (diluted)	0.5 - 0.7
Primer	Unisil Primer	0.50 - 0.67

#### SEAMS & DETAILS<sup>1</sup>

Treatment Type	Product	Total (Gal/Sq)	DFT* (mils)
3-Coursed Rates	Unisil Silicone Flashing and Fabric	2.50	44
Flashing Grade Only Rates	Unisil Silicone Flashing	1.25	19

Note: For other product options, please refer to our Seam Treatment Guide.

#### CORRUGATED STRUCTURAL TRANSITE PANELS

Coverage Term	Coating			Total		Warranties/Guarantees Available	
	1st Coat (Gal/Sq)	2nd Coat (Gal/Sq)	3rd Coat (Gal/Sq)	Gal/Sq	DFT* (mils)	Emerald Pledge™	Diamond Pledge™
10 Year	1.50	1.00		2.50	27	Yes	No
15 Year	1.25	1.00	1.00	3.25	35	Yes	No
20 Year	1.50	1.50	1.00	4.00	44	Yes	No

\* Dry Film Thickness (DFT) is rounded to nearest mil, and is theoretical. Actual DFT will vary dependent on substrate profile, application technique and waste factor. Note: DFT for 3-coursed rates includes 6 mils for the fabric.

<sup>1</sup>Flashing rates are based on a 6" (152 mm) width, rates will double for 12" (305 mm) width.

**Important note:** Corrugated structural transite panels may contain asbestos. Follow all applicable local, state and federal regulations concerning asbestos. Under no circumstances does GAF have any liability for any damages, costs or expenses arising out of or associated with the pre-existing presence of asbestos containing materials upon the roof to which the new GAF roofing materials are being applied.

# UNISIL II QUICK SPEC

## SPRAY POLYURETHANE FOAM (UN-9)

**NOTE:** The following "Quick Spec" is an abbreviated specification and is not meant to replace the detailed specification. Complete 3-part CSI System Specifications are available at [www.gaf.com](http://www.gaf.com).



### METHOD REQUIREMENTS

#### Required:

- Moisture survey required
- Remove and replace any wet areas
- Repair membrane with like materials
- Roof must be clean, dry and tight
- No rain, dew, fog, or freezing temperatures in forecast for 24 hours
- Adhesion test required
- Power washing required

#### Recommendations:

- Refer to Technical Data Sheet for product specific application and surface temperature restrictions.

#### Installation Overview:

1. Before coating is applied, an adhesion test is required to ensure an adhesion minimum of 2.0 pounds per linear inch (PLI). Test patches to be applied with rates listed below.
2. Power-wash substrate to remove contaminants that could negatively affect adhesion. Allow roof to completely dry.
3. Treat all roof penetrations, drains, curbs, and scuppers. (Refer to Substrate Preparation section for requirements)
4. Apply coating per the chart below:

### CLEAN / PRIME

	Product	Rate (Gal/Sq)
Cleaner	UCC Cleaner ( <i>diluted</i> )	0.5 - 0.7
Primer	Not required	

### SEAMS & DETAILS<sup>1</sup>

Treatment Type	Product	Total (Gal/Sq)	DFT* (mils)
3-Coursed Rates	Unisil Silicone Flashing and Fabric	2.50	44
Flashing Grade Only Rates	Unisil Silicone Flashing	1.25	19

*Note: For other product options, please refer to our Seam Treatment Guide.*

### SPRAY POLYURETHANE FOAM

Coverage Term	Coating			Total		Warranties/Guarantees Available	
	1st Coat (Gal/Sq)	2nd Coat (Gal/Sq)	3rd Coat (Gal/Sq)	Gal/Sq	DFT* (mils)	Emerald Pledge™	Diamond Pledge™
10 Year	1.50	1.00		2.50	27	Yes	No
15 Year	1.25	1.00	1.00	3.25	35	Yes	No
20 Year	1.50	1.50	1.00	4.00	44	Yes	No

\* Dry Film Thickness (DFT) is rounded to nearest mil, and is theoretical. Actual DFT will vary dependent on substrate profile, application technique and waste factor.

Note: DFT for 3-coursed rates includes 6 mils for the fabric.

<sup>1</sup>Flashing rates are based on a 6" (152 mm) width, rates will double for 12" (305 mm) width.

# UNISIL II QUICK SPEC

## TPO (UN-10)

**NOTE:** The following “Quick Spec” is an abbreviated specification and is not meant to replace the detailed specification. Complete 3-part CSI System Specifications are available at [www.gaf.com](http://www.gaf.com).



### METHOD REQUIREMENTS

#### Required:

- Moisture survey required
- Remove and replace any wet areas
- Repair membrane with like materials
- Roof must be clean, dry and tight
- No rain, dew, fog, or freezing temperatures in forecast for 24 hours
- Adhesion test required
- Power washing required

#### Recommendations:

- New membranes should be aged at least 90+ days.
- Refer to Technical Data Sheet for product specific application and surface temperature restrictions.

#### Installation Overview:

1. Before coating is applied, an adhesion test is required to ensure an adhesion minimum of 2.0 pounds per linear inch (PLI). Test patches to be applied with rates listed below.
2. Power-wash substrate to remove contaminants that could negatively affect adhesion. Allow roof to completely dry.
3. Prime per chart below.
4. Treat all roof penetrations, drains, curbs, and scuppers. (Refer to Substrate Preparation section for requirements)
5. All loose seams must be 3-coursed. All other seams must be treated with flashing grade only, no fabric required. (Refer to Seam Treatment Guide for requirements)
6. Apply coating per the chart below:

#### CLEAN / PRIME

	Product	Rate (Gal/Sq)
Cleaner	UCC Cleaner ( <i>diluted</i> )	0.5 - 0.7
Primer	TPO Red Primer	0.25

#### SEAMS & DETAILS<sup>1</sup>

Treatment Type	Product	Total (Gal/Sq)	DFT* (mils)
3-Coursed Rates	Unisil Silicone Flashing and Fabric	2.50	44
Flashing Grade Only Rates	Unisil Silicone Flashing	1.25	19

Note: For other product options, please refer to our Seam Treatment Guide.

#### TPO

Coverage Term	Coating			Total		Warranties/Guarantees Available	
	1st Coat (Gal/Sq)	2nd Coat (Gal/Sq)	3rd Coat (Gal/Sq)	Gal/Sq	DFT* (mils)	Emerald Pledge™	Diamond Pledge™
10 Year	1.00	1.00		2.00	22	Yes	No
15 Year	1.25	1.50		2.75	30	Yes	No
20 Year	1.00	1.50	1.00	3.50	38	Yes	No

\* Dry Film Thickness (DFT) is rounded to nearest mil, and is theoretical. Actual DFT will vary dependent on substrate profile, application technique and waste factor.

Note: DFT for 3-coursed rates includes 6 mils for the fabric.

<sup>1</sup>Flashing rates are based on a 6" (152 mm) width, rates will double for 12" (305 mm) width.



## UNISIL HS II QUICK SPEC DIRECTORY

Spec Number	Substrate Specification	Page #
UH-1	Unisil HS II over Metal	49
UH-2	Unisil HS II over PVC	50
UH-3	Unisil HS II Hypalon®	51
UH-4	Unisil HS II over EPDM	52
UH-5	Unisil HS II Smooth Asphaltic	53
UH-6	Unisil HS II Granulated Asphaltic	54
UH-7	Unisil HS II over Structural Concrete	55
UH-8	Unisil HS II over Corrugated Structural Transite Panels	56
UH-9	Unisil HS II over Spray Polyurethane Foam	57
UH-10	Unisil HS II over TPO	58

*Quick Specs are abbreviated specifications and are not meant to replace detailed specifications. Complete 3-part CSI System Specifications are available at [www.gaf.com](http://www.gaf.com).*

# UNISIL HS II QUICK SPEC

## METAL (UH-1)

**NOTE:** The following "Quick Spec" is an abbreviated specification and is not meant to replace the detailed specification. Complete 3-part CSI System Specifications are available at [www.gaf.com](http://www.gaf.com).



### METHOD REQUIREMENTS

#### Required:

- Roof must be clean, dry and tight
- No rain, dew, fog, or freezing temperatures in forecast for 24 hours
- Adhesion test required
- Power washing required

#### Recommendations:

- Refer to Technical Data Sheet for product specific application and surface temperature restrictions.
- Rust should be removed with a wire brush prior to coating, and structural repairs should be made with like-materials as needed.

#### Installation Overview:

1. Before coating is applied, an adhesion test is required to ensure an adhesion minimum of 2.0

2. Tighten/replace existing fasteners. Encapsulate with appropriate flashing material.
3. Power-wash substrate to remove contaminants that could negatively affect adhesion. Allow roof to completely dry.
4. Install crickets to divert water and complete other necessary sheet metal repairs.
5. Treat all roof penetrations, drains, curbs, and scuppers. (Refer to Substrate Preparation section for requirements)
6. Horizontal seams must be 3-coursed. Overlap and trapezoidal vertical seams must be treated with flashing grade only. Other vertical seams may forgo treatment **IF** the seal/tape is intact on the seam or if they are double locked. (Refer to Seam Treatment Guide for requirements)
7. Apply coating per the chart below:

### CLEAN / PRIME

	Product	Rate (Gal/Sq)
Cleaner	UCC Cleaner ( <i>diluted</i> )	0.5 - 0.7
Primer	Not required	

### SEAMS & DETAILS<sup>1</sup>

Treatment Type	Product	Total (Gal/Sq)	DFT* (mils)
3-Coursed Rates	Unisil Silicone Flashing and Fabric	2.50	44
Flashing Grade Only Rates	Unisil Silicone Flashing	1.25	19

*Note: For other product options, please refer to our Seam Treatment Guide.*

### METAL

Coverage Term	Total		Warranties/Guarantees Available	
	Gal/Sq‡	DFT* (mils)	Emerald Pledge™	Diamond Pledge™
10 Year	1.50	23	Yes	Yes
15 Year	2.00	31	Yes	Yes
20 Year	2.50	38	Yes	Yes

\* Dry Film Thickness (DFT) is rounded to nearest mil, and is theoretical. Actual DFT will vary dependent on substrate profile, application technique and waste factor. Note: DFT for 3-coursed rates includes 6 mils for the fabric.

<sup>1</sup>Flashing rates are based on a 6" (152 mm) width, rates will double for 12" (305 mm) width.

‡Coating may be applied at the maximum rate of 2.0 gal/sq per pass, as long as the substrate and slope conditions allow. Maximum slope cannot exceed 2:12.

# UNISIL HS II QUICK SPEC

## PVC (UH-2)

**NOTE:** The following "Quick Spec" is an abbreviated specification and is not meant to replace the detailed specification. Complete 3-part CSI System Specifications are available at [www.gaf.com](http://www.gaf.com).



### METHOD REQUIREMENTS

#### Required:

- Moisture survey required
- Remove and replace any wet areas
- Repair membrane with like materials
- Roof must be clean, dry and tight
- No rain, dew, fog, or freezing temperatures in forecast for 24 hours
- Adhesion test required
- Power washing required

#### Recommendations:

- Refer to Technical Data Sheet for product specific application and surface temperature restrictions.

#### Installation Overview:

1. Before coating is applied, an adhesion test is required to ensure an adhesion minimum of 2.0 pounds per linear inch (PLI). Test patches to be applied with rates listed below.
2. Power-wash substrate to remove contaminants that could negatively affect adhesion. Allow roof to completely dry.
3. Prime per chart below.
4. Treat all roof penetrations, drains, curbs, and scuppers. (Refer to Substrate Preparation section for requirements)
5. All loose seams must be 3-coursed. All other seams must be treated with flashing grade only, no fabric required. (Refer to Seam Treatment Guide for requirements)
6. Apply coating per the chart below:

#### CLEAN / PRIME

	Product	Rate (Gal/Sq)
Cleaner	UCC Cleaner ( <i>diluted</i> )	0.5 - 0.7
Primer	Unisil Primer	0.33

#### SEAMS & DETAILS<sup>1</sup>

Treatment Type	Product	Total (Gal/Sq)	DFT* (mils)
3-Coursed Rates	Unisil Silicone Flashing and Fabric	2.50	44
Flashing Grade Only Rates	Unisil Silicone Flashing	1.25	19

*Note: For other product options, please refer to our Seam Treatment Guide.*

#### PVC

Coverage Term	Total		Warranties/Guarantees Available	
	Gal/Sq‡	DFT* (mils)	Emerald Pledge™	Diamond Pledge™
10 Year	1.50	23	Yes	No
15 Year	2.00	31	Yes	No
20 Year	2.50	38	Yes	No

\* Dry Film Thickness (DFT) is rounded to nearest mil, and is theoretical. Actual DFT will vary dependent on substrate profile, application technique and waste factor.

Note: DFT for 3-coursed rates includes 6 mils for the fabric.

<sup>1</sup>Flashing rates are based on a 6" (152 mm) width, rates will double for 12" (305 mm) width.

‡Coating may be applied at the maximum rate of 2.0 gal/sq per pass, as long as the substrate and slope conditions allow. Maximum slope cannot exceed 2:12.

# UNISIL HS II QUICK SPEC

## Hypalon® (UH-3)

**NOTE:** The following "Quick Spec" is an abbreviated specification and is not meant to replace the detailed specification. Complete 3-part CSI System Specifications are available at [www.gaf.com](http://www.gaf.com).



### METHOD REQUIREMENTS

#### Required:

- Moisture survey required
- Remove and replace any wet areas
- Repair membrane with like materials
- Roof must be clean, dry and tight
- No rain, dew, fog, or freezing temperatures in forecast for 24 hours
- Adhesion test required
- Power washing required

#### Recommendations:

- Refer to Technical Data Sheet for product specific application and surface temperature restrictions.

#### Installation Overview:

1. Before coating is applied, an adhesion test is required to ensure an adhesion minimum of 2.0 pounds per linear inch (PLI). Test patches to be applied with rates listed below.
2. Power-wash substrate to remove contaminants that could negatively affect adhesion. Allow roof to completely dry.
3. Prime per chart below.
4. Treat all roof penetrations, drains, curbs, and scuppers. (Refer to Substrate Preparation section for requirements)
5. All loose seams must be 3-coursed. All other seams must be treated with flashing grade only, no fabric required. (Refer to Seam Treatment Guide for requirements)
6. Apply coating per the chart below:

#### CLEAN / PRIME

	Product	Rate (Gal/Sq)
Cleaner	UCC Cleaner (diluted)	0.5 - 0.7
Primer	Unisil Primer	0.33

#### SEAMS & DETAILS<sup>1</sup>

Treatment Type	Product	Total (Gal/Sq)	DFT* (mils)
3-Coursed Rates	Unisil Silicone Flashing and Fabric	2.50	44
Flashing Grade Only Rates	Unisil Silicone Flashing	1.25	19

Note: For other product options, please refer to our Seam Treatment Guide.

#### Hypalon®

Coverage Term	Total		Warranties/Guarantees Available	
	Gal/Sq‡	DFT* (mils)	Emerald Pledge™	Diamond Pledge™
10 Year	1.50	23	Yes	No
15 Year	2.00	31	Yes	No
20 Year	2.50	38	Yes	No

\* Dry Film Thickness (DFT) is rounded to nearest mil, and is theoretical. Actual DFT will vary dependent on substrate profile, application technique and waste factor.

Note: DFT for 3-coursed rates includes 6 mils for the fabric.

<sup>1</sup>Flashing rates are based on a 6" (152 mm) width, rates will double for 12" (305 mm) width.

‡Coating may be applied at the maximum rate of 2.0 gal/sq per pass, as long as the substrate and slope conditions allow.

# UNISIL HS II QUICK SPEC

## EPDM (UH-4)

**NOTE:** The following "Quick Spec" is an abbreviated specification and is not meant to replace the detailed specification. Complete 3-part CSI System Specifications are available at [www.gaf.com](http://www.gaf.com).



### METHOD REQUIREMENTS

#### Required:

- Moisture survey required
- Remove and replace any wet areas
- Repair membrane with like materials
- Roof must be clean, dry and tight
- No rain, dew, fog, or freezing temperatures in forecast for 24 hours
- Adhesion test required
- Power washing required

#### Recommendations:

- Refer to Technical Data Sheet for product specific application and surface temperature restrictions.

#### Installation Overview:

1. Before coating is applied, an adhesion test is required to ensure an adhesion minimum of 2.0 pounds per linear inch (PLI). Test patches to be applied with rates listed below.
2. Power-wash substrate to remove contaminants that could negatively affect adhesion. Allow roof to completely dry.
3. Prime per chart below.
4. Treat all roof penetrations, drains, curbs, and scuppers. (Refer to Substrate Preparation section for requirements)
5. All loose seams must be 3-coursed. All other seams must be treated with flashing grade only, no fabric required. (Refer to Seam Treatment Guide for requirements)
6. Apply coating per the chart below:

#### CLEAN / PRIME

	Product	Rate (Gal/Sq)
Cleaner	UCC Cleaner ( <i>diluted</i> )	0.5 - 0.7
Primer	CleanAct Rinsable Primer	0.20
	<b>AND</b> Unisil Primer	0.33

#### SEAMS & DETAILS<sup>1</sup>

Treatment Type	Product	Total (Gal/Sq)	DFT* (mils)
3-Coursed Rates	Unisil Silicone Flashing and Fabric	2.50	44
Flashing Grade Only Rates	Unisil Silicone Flashing	1.25	19

Note: For other product options, please refer to our Seam Treatment Guide.

#### EPDM

Coverage Term	Total		Warranties/Guarantees Available	
	Gal/Sq‡	DFT* (mils)	Emerald Pledge™	Diamond Pledge™
10 Year	1.50	23	Yes	No
15 Year	2.00	31	Yes	No
20 Year	2.50	38	Yes	No

\* Dry Film Thickness (DFT) is rounded to nearest mil, and is theoretical. Actual DFT will vary dependent on substrate profile, application technique and waste factor.

Note: DFT for 3-coursed rates includes 6 mils for the fabric.

<sup>1</sup>Flashing rates are based on a 6" (152 mm) width, rates will double for 12" (305 mm) width.

‡Coating may be applied at the maximum rate of 2.0 gal/sq per pass, as long as the substrate and slope conditions allow. Maximum slope cannot exceed 2:12.

# UNISIL HS II QUICK SPEC

## SMOOTH ASPHALTIC (UH-5)

**NOTE:** The following “Quick Spec” is an abbreviated specification and is not meant to replace the detailed specification. Complete 3-part CSI System Specifications are available at [www.gaf.com](http://www.gaf.com).



### METHOD REQUIREMENTS

#### Required:

- Moisture survey required
- Remove and replace any wet areas
- Repair membrane with like materials
- Roof must be clean, dry and tight
- No rain, dew, fog, or freezing temperatures in forecast for 24 hours
- Adhesion test required
- Power washing required

#### Restrictions:

Do not apply over gravel surfaced substrates.

#### Recommendations:

- Refer to Technical Data Sheet for product specific application and surface temperature restrictions.
- New membranes should be aged at least 30 days; 90 + days is ideal.

#### Installation Overview:

1. Before coating is applied, an adhesion test is required to ensure an adhesion minimum of 2.0 pounds per linear inch (PLI). Test patches to be applied with rates listed below.
2. Power-wash substrate to remove contaminants that could negatively affect adhesion. Allow roof to completely dry.
3. Prime per chart below.
4. Treat “alligatored” areas, surface cracks, roof penetrations, drains, curbs and scuppers. (Refer to Substrate Preparation section for requirements)
5. All loose seams must be 3-coursed. All other seams must be treated with flashing grade only, no fabric required. (Refer to Seam Treatment Guide for requirements)
6. Apply coating per the chart below:

### CLEAN / PRIME

	Product	Rate (Gal/Sq)
Cleaner	UCC Cleaner ( <i>diluted</i> )	0.5 - 0.7
Primer	Unisil Primer	0.67 - 1.0

### SEAMS & DETAILS <sup>1</sup>

Treatment Type	Product	Total (Gal/Sq)	DFT* (mils)
3-Coursed Rates	Unisil Silicone Flashing and Fabric	2.50	44
Flashing Grade Only Rates	Unisil Silicone Flashing	1.25	19

Note: For other product options, please refer to our Seam Treatment Guide.

### SMOOTH ASPHALTIC

Coverage Term	Total		Warranties/Guarantees Available	
	Gal/Sq‡	DFT* (mils)	Emerald Pledge™	Diamond Pledge™
10 Year	1.75	27	Yes	No
15 Year	2.25	35	Yes	No
20 Year	2.75	42	Yes	No

\* Dry Film Thickness (DFT) is rounded to nearest mil, and is theoretical. Actual DFT will vary dependent on substrate profile, application technique and waste factor.

Note: DFT for 3-coursed rates includes 6 mils for the fabric.

‡Flashing rates are based on a 6" (152 mm) width, rates will double for 12" (305 mm) width.

‡Coating may be applied at the maximum rate of 2.0 gal/sq per pass, as long as the substrate and slope conditions allow.

# UNISIL HS II QUICK SPEC

## GRANULATED ASPHALTIC (UH-6)

**NOTE:** The following "Quick Spec" is an abbreviated specification and is not meant to replace the detailed specification. Complete 3-part CSI System Specifications are available at [www.gaf.com](http://www.gaf.com).



### METHOD REQUIREMENTS

#### Required:

- Moisture survey required
- Remove and replace any wet areas
- Repair membrane with like materials
- Roof must be clean, dry and tight
- No rain, dew, fog, or freezing temperatures in forecast for 24 hours
- Adhesion test required
- Power washing required

#### Restrictions:

Do not apply over gravel surfaced substrates.

#### Recommendations:

- Refer to Technical Data Sheet for product specific application and surface temperature restrictions.
- New membranes should be aged at least 30 days; 90 + days is ideal.

#### Installation Overview:

1. Before coating is applied, an adhesion test is required to ensure an adhesion minimum of 2.0 pounds per linear inch (PLI). Test patches to be applied with rates listed below.
2. Power-wash substrate to remove contaminants that could negatively affect adhesion. Allow roof to completely dry.
3. Prime per chart below.
4. Treat "alligatored" areas, surface cracks, roof penetrations, drains, curbs and scuppers. (Refer to Substrate Preparation section for requirements)
5. All loose seams must be 3-coursed. All other seams must be treated with flashing grade only, no fabric required. (Refer to Seam Treatment Guide for requirements)
6. Apply coating per the chart below:

### CLEAN / PRIME

	Product	Rate (Gal/Sq)
Cleaner	UCC Cleaner (diluted)	0.5 - 0.7
Primer	Unisil Primer	1.00 - 1.33

### SEAMS & DETAILS <sup>1</sup>

Treatment Type	Product	Total (Gal/Sq)	DFT* (mils)
3-Coursed Rates	Unisil Silicone Flashing and Fabric	2.50	44
Flashing Grade Only Rates	Unisil Silicone Flashing	1.25	19

Note: For other product options, please refer to our Seam Treatment Guide.

### GRANULATED ASPHALTIC

Coverage Term	Total		Warranties/Guarantees Available	
	Gal/Sq‡	DFT* (mils)	Emerald Pledge™	Diamond Pledge™
10 Year	1.75	27	Yes	No
15 Year	2.25	35	Yes	No
20 Year	2.75	42	Yes	No

\* Dry Film Thickness (DFT) is rounded to nearest mil, and is theoretical. Actual DFT will vary dependent on substrate profile, application technique and waste factor.

Note: DFT for 3-coursed rates includes 6 mils for the fabric.

† Flashing rates are based on a 6" (152 mm) width, rates will double for 12" (305 mm) width.

‡ Coating may be applied at the maximum rate of 2.0 gal/sq per pass, as long as the substrate and slope conditions allow. Maximum slope cannot exceed 2:12.

# UNISIL HS II QUICK SPEC

## STRUCTURAL CONCRETE (UH-7)

**NOTE:** The following "Quick Spec" is an abbreviated specification and is not meant to replace the detailed specification. Complete 3-part CSI System Specifications are available at [www.gaf.com](http://www.gaf.com).



### METHOD REQUIREMENTS

#### Required:

- Moisture survey required (Must contain less than 8% moisture)
- Repair deteriorated sections with like materials. Allow repairs to cure properly
- Roof must be clean, dry and tight
- No rain, dew, fog, or freezing temperatures in forecast for 24 hours
- Adhesion test required
- Power washing required
- Concrete must be fully cured

#### Recommendations:

- Refer to Technical Data Sheet for product specific application and surface temperature restrictions.

#### Installation Overview:

1. Before coating is applied, an adhesion test is required to ensure an adhesion minimum of 2.0 pounds per linear inch (PLI). Test patches to be applied with rates listed below.
2. Power-wash substrate to remove contaminants that could negatively affect adhesion. Allow roof to completely dry.
3. Prime per chart below.
4. Treat all roof penetrations, drains, curbs, and scuppers. (Refer to Substrate Preparation section for requirements)
5. Treat structural joints with backer rod and compatible sealant prior to seam treatment. (Refer to Seam Treatment Guide for requirements)
6. Control Joints in excess of 1/16" (1.6 mm) shall be caulked with compatible caulk.
7. Apply coating per the chart below:

### CLEAN / PRIME

	Product	Rate (Gal/Sq)
Cleaner	UCC Cleaner (diluted)	0.5 - 0.7
Primer	Unisil Primer	0.50 - 0.67

### SEAMS & DETAILS<sup>1</sup>

Treatment Type	Product	Total (Gal/Sq)	DFT* (mils)
3-Coursed Rates	Unisil Silicone Flashing and Fabric	2.50	44
Flashing Grade Only Rates	Unisil Silicone Flashing	1.25	19

Note: For other product options, please refer to our Seam Treatment Guide.

### STRUCTURAL CONCRETE

Coverage Term	Total		Warranties/Guarantees Available	
	Gal/Sq‡	DFT* (mils)	Emerald Pledge™	Diamond Pledge™
10 Year	1.75	27	Yes	No
15 Year	2.25	35	Yes	No
20 Year	2.75	42	Yes	No

\* Dry Film Thickness (DFT) is rounded to nearest mil, and is theoretical. Actual DFT will vary dependent on substrate profile, application technique and waste factor.

Note: DFT for 3-coursed rates includes 6 mils for the fabric.

<sup>1</sup>Flashing rates are based on a 6" (152 mm) width, rates will double for 12" (305 mm) width.

‡Coating may be applied at the maximum rate of 2.0 gal/sq per pass, as long as the substrate and slope conditions allow. Maximum slope cannot exceed 2:12.



# UNISIL HS II QUICK SPEC

## CORRUGATED STRUCTURAL TRANSITE PANELS (UH-8)

**NOTE:** The following "Quick Spec" is an abbreviated specification and is not meant to replace the detailed specification. Complete 3-part CSI System Specifications are available at [www.gaf.com](http://www.gaf.com).



### METHOD REQUIREMENTS

#### Required:

- Moisture survey required
- Remove and replace any wet areas
- Repair membrane with like materials
- Roof must be clean, dry and tight
- No rain, dew, fog, or freezing temperatures in forecast for 24 hours
- Adhesion test required
- Power washing required

#### Recommendations:

- Refer to Technical Data Sheet for product specific application and surface temperature restrictions.

#### Installation Overview:

1. Before coating is applied, an adhesion test is required to ensure an adhesion minimum of 2.0 pounds per linear inch (PLI). Test patches to be applied with rates listed below.
2. Power-wash substrate to remove contaminants that could negatively affect adhesion. Allow roof to completely dry.
3. Tighten/replace existing fasteners. Encapsulate with appropriate flashing material.
4. Prime per chart below.
5. Treat all roof penetrations, drains, curbs, and scuppers. (Refer to Substrate Preparation section for requirements)
6. Treat transite gaps in excess of 1/16" with compatible caulk prior to seam treatment. (Refer to Substrate Preparation Seam Treatment Guide for requirements)
7. Apply coating per the chart below:

#### CLEAN / PRIME

	Product	Rate (Gal/Sq)
Cleaner	UCC Cleaner ( <i>diluted</i> )	0.5 - 0.7
Primer	Unisil Primer	0.50 - 0.67

#### SEAMS & DETAILS <sup>1</sup>

Treatment Type	Product	Total (Gal/Sq)	DFT* (mils)
3-Coursed Rates	Unisil Silicone Flashing and Fabric	2.50	44
Flashing Grade Only Rates	Unisil Silicone Flashing	1.25	19

Note: For other product options, please refer to our Seam Treatment Guide.

#### CORRUGATED STRUCTURAL TRANSITE PANELS

Coverage Term	Total		Warranties/Guarantees Available	
	Gal/Sq‡	DFT* (mils)	Emerald Pledge™	Diamond Pledge™
10 Year	1.75	27	Yes	No
15 Year	2.25	35	Yes	No
20 Year	2.75	42	Yes	No

\* Dry Film Thickness (DFT) is rounded to nearest mil, and is theoretical. Actual DFT will vary dependent on substrate profile, application technique and waste factor.

Note: DFT for 3-coursed rates includes 6 mils for the fabric.

<sup>1</sup>Flashing rates are based on a 6" (152 mm) width, rates will double for 12" (305 mm) width.

‡Coating may be applied at the maximum rate of 2.0 gal/sq per pass, as long as the substrate and slope conditions allow. Maximum slope cannot exceed 2:12.

**Important note** Corrugated structural transite panels may contain asbestos. Follow all applicable local, state and federal regulations concerning asbestos. Under no circumstances does GAF have any liability for any damages, costs or expenses arising out of or associated with the pre-existing presence of asbestos containing materials or any other alleged hazardous substances or materials upon the roof to which the new GAF roofing materials are being applied.

# UNISIL HS II QUICK SPEC

## SPRAY POLYURETHANE FOAM (UH-9)

**NOTE:** The following "Quick Spec" is an abbreviated specification and is not meant to replace the detailed specification. Complete 3-part CSI System Specifications are available at [www.gaf.com](http://www.gaf.com).



### METHOD REQUIREMENTS

#### Required:

- Moisture survey required
- Remove and replace any wet areas
- Repair membrane with like materials
- Roof must be clean, dry and tight
- No rain, dew, fog, or freezing temperatures in forecast for 24 hours
- Adhesion test required
- Power washing required

#### Recommendations:

- Refer to Technical Data Sheet for product specific application and surface temperature restrictions.

#### Installation Overview:

1. Before coating is applied, an adhesion test is required to ensure an adhesion minimum of 2.0 pounds per linear inch (PLI). Test patches to be applied with rates listed below.
2. Power-wash substrate to remove contaminants that could negatively affect adhesion. Allow roof to completely dry.
3. Treat all roof penetrations, drains, curbs, and scuppers. (Refer to Substrate Preparation section for requirements)
4. Apply coating per the chart below:

CLEAN / PRIME		
	Product	Rate (Gal/Sq)
Cleaner	UCC Cleaner ( <i>diluted</i> )	0.5 - 0.7
Primer	Not Required	

SEAMS & DETAILS <sup>1</sup>			
Treatment Type	Product	Total (Gal/Sq)	DFT* (mils)
3-Coursed Rates	Unisil Silicone Flashing and Fabric	2.50	44
Flashing Grade Only Rates	Unisil Silicone Flashing	1.25	19

*Note: For other product options, please refer to our Seam Treatment Guide.*

SPRAY POLYURETHANE FOAM				
Coverage Term	Total		Warranties/Guarantees Available	
	Gal/Sq‡	DFT* (mils)	Emerald Pledge™	Diamond Pledge™
10 Year	1.75	27	Yes	No
15 Year	2.25	35	Yes	No
20 Year	2.75	42	Yes	No

\* Dry Film Thickness (DFT) is rounded to nearest mil, and is theoretical. Actual DFT will vary dependent on substrate profile, application technique and waste factor.

Note: DFT for 3-coursed rates includes 6 mils for the fabric.

<sup>1</sup> Flashing rates are based on a 6" (152 mm) width, rates will double for 12" (305 mm) width.

‡ Coating may be applied at the maximum rate of 2.0 gal/sq per pass, as long as the substrate and slope conditions allow. Maximum slope cannot exceed 2:12.

# UNISIL HS II QUICK SPEC

## TPO (UH-10)

**NOTE:** The following "Quick Spec" is an abbreviated specification and is not meant to replace the detailed specification. Complete 3-part CSI System Specifications are available at [www.gaf.com](http://www.gaf.com).



### METHOD REQUIREMENTS

#### Required:

- Moisture survey required
- Remove and replace any wet areas
- Repair membrane with like materials
- Roof must be clean, dry and tight
- No rain, dew, fog, or freezing temperatures in forecast for 24 hours
- Adhesion test required
- Power washing required

#### Recommendations:

- Refer to Technical Data Sheet for product specific application and surface temperature restrictions.
- New membranes should be aged at least 90 days.

#### Installation Overview:

1. Before coating is applied, an adhesion test is required to ensure an adhesion minimum of 2.0 pounds per linear inch (PLI). Test patches to be applied with rates listed below.
2. Power-wash substrate to remove contaminants that could negatively affect adhesion. Allow roof to completely dry.
3. Prime per chart below.
4. Treat all roof penetrations, drains, curbs, and scuppers. (Refer to Substrate Preparation section for requirements)
5. All loose seams must be 3-coursed. All other seams must be treated with flashing grade only, no fabric required. (Refer to Seam Treatment Guide for requirements)
6. Apply coating per the chart below:

#### CLEAN / PRIME

	Product	Rate (Gal/Sq)
Cleaner	UCC Cleaner ( <i>diluted</i> )	0.5 - 0.7
Primer	TPO Red Primer	0.25

#### SEAMS & DETAILS<sup>1</sup>

Treatment Type	Product	Total (Gal/Sq)	DFT* (mils)
3-Coursed Rates	Unisil Silicone Flashing and Fabric	2.50	44
Flashing Grade Only Rates	Unisil Silicone Flashing	1.25	19

Note: For other product options, please refer to our Seam Treatment Guide.

#### TPO

Coverage Term	Total		Warranties/Guarantees Available	
	Gal/Sq‡	DFT* (mils)	Emerald Pledge™	Diamond Pledge™
10 Year	1.50	23	Yes	No
15 Year	2.00	31	Yes	No
20 Year	2.50	38	Yes	No

\* Dry Film Thickness (DFT) is rounded to nearest mil, and is theoretical. Actual DFT will vary dependent on substrate profile, application technique and waste factor.

Note: DFT for 3-coursed rates includes 6 mils for the fabric.

<sup>1</sup>Flashing rates are based on a 6" (152 mm) width, rates will double for 12" (305 mm) width.

‡Coating may be applied at the maximum rate of 2.0 gal/sq per pass, as long as the substrate and slope conditions allow. Maximum slope cannot exceed 2:12.

## ELASTUFF® 101 WITH ELASTUFF® 103 QUICK SPEC DIRECTORY

Spec Number	Substrate Specification	Page #
EL-1	Elastuff® over Metal	60
EL-2	Elastuff® over Smooth Asphaltic	61
EL-3	Elastuff® over Granulated Asphaltic	62
EL-4	Elastuff® over Structural Concrete	63
EL-5	Elastuff® over Corrugated Structural Transite Panels	64
EL-6	Elastuff® over Spray Polyurethane Foam	65

*Quick Specs are abbreviated specifications and are not meant to replace detailed specifications. Complete 3-part CSI System Specifications are available at [www.gaf.com](http://www.gaf.com).*

# ELASTUFF® 101 WITH ELASTUFF® 103 QUICK SPEC METAL (EL-1)

**NOTE:** The following "Quick Spec" is an abbreviated specification and is not meant to replace the detailed specification. Complete 3-part CSI System Specifications are available at [www.gaf.com](http://www.gaf.com).



## METHOD REQUIREMENTS

### Required:

- Roof must be clean, dry and tight
- No rain, dew, fog, or freezing temperatures in forecast for 24 hours
- Adhesion test required
- Power washing required

### Recommendations:

- Refer to Technical Data Sheet for product specific application and surface temperature restrictions.
- Rust should be removed with a wire brush prior to coating, and structural repairs should be made with like-materials as needed.

### Installation Overview:

1. Before coating is applied, an adhesion test is required to ensure an adhesion minimum of 2.0

2. Tighten/replace existing fasteners. Encapsulate with appropriate flashing material.
3. Power-wash substrate to remove contaminants that could negatively affect adhesion. Allow roof to completely dry.
4. Install crickets to divert water and complete other necessary sheet metal repairs.
5. Prime per chart below.
6. Treat all roof penetrations, drains, curbs, and scuppers. (Refer to Substrate Preparation section for requirements)
7. Horizontal seams must be 3-coursed. Overlap and trapezoidal vertical seams must be treated with flashing grade only. Other vertical seams may forgo treatment **IF** the seal/tape is intact on the seam or if they are double locked. (Refer to Seam Treatment Guide for requirements)
8. Apply coating per the chart below:

### CLEAN / PRIME

	Product	Rate (Gal/Sq)
Cleaner	UCC Cleaner ( <i>diluted</i> )	0.5 - 0.7
Primer	Lock-Down Primer	0.33 - 0.40

### SEAMS & DETAILS<sup>1</sup>

Treatment Type	Product	Total (Gal/Sq)	DFT* (mils)
3-Coursed Rates	Elastuff® 101 and Fabric	4.00	57
Flashing Grade Only Rates	Elastuff® 101	2.00	26

Note: For other product options, please refer to our Seam Treatment Guide.

<sup>1</sup>Flashing rates are based on a 6" (152 mm) width, rates will double for 12" (305 mm) width.

### METAL

Coverage Term	Elastuff® 101		Elastuff® 103		Total		Warranties/Guarantees Available	
	Base Coat (Gal/Sq)	DFT* (mils)	Top Coat Gal/Sq	DFT* (mils)	Total Gal/Sq	DFT* (mils)	Emerald Pledge™	Diamond Pledge™
10 Year	1.00	13	1.00	9	2.00	22	Yes	Yes
15 Year	1.25	16	1.50	14	2.75	30	Yes	Yes

\* Dry Film Thickness (DFT) is rounded to nearest mil, and is theoretical. Actual DFT will vary dependent on substrate profile, application technique and waste factor. Note: DFT for 3-coursed rates includes 6 mils for the fabric.

# ELASTUFF® 101 WITH ELASTUFF® 103 QUICK SPEC

## SMOOTH ASPHALTIC (EL-2)

**NOTE:** The following "Quick Spec" is an abbreviated specification and is not meant to replace the detailed specification. Complete 3-part CSI System Specifications are available at [www.gaf.com](http://www.gaf.com).



### METHOD REQUIREMENTS

#### Required:

- Moisture survey required
- Remove and replace any wet areas
- Repair membrane with like materials
- Roof must be clean, dry and tight
- No rain, dew, fog, or freezing temperatures in forecast for 24 hours
- Adhesion test required
- Power washing required

#### Restrictions:

Do not apply over gravel surfaced substrates.

#### Recommendations:

- Refer to Technical Data Sheet for product specific application and surface temperature restrictions.
- New membranes should be aged at least 30 days; 90+ days is ideal.

#### Installation Overview:

1. Before coating is applied, an adhesion test is required to ensure an adhesion minimum of 2.0 pounds per linear inch (PLI). Test patches to be applied with rates listed below.
2. Power-wash substrate to remove contaminants that could negatively affect adhesion. Allow roof to completely dry.
3. All loose seams must be 3-coursed. All other seams must be treated with flashing grade only, no fabric required. (Refer to Substrate Preparation section for requirements)
4. Treat "alligatored" areas, surface cracks, roof penetrations, drains, curbs and scuppers. (Refer to Substrate Preparation section for requirements)
5. Apply coating per the chart below:

### CLEAN / PRIME

	Product	Rate (Gal/Sq)
Cleaner	UCC Cleaner ( <i>diluted</i> )	0.5 - 0.7
Primer	Not Required	

### SEAMS & DETAILS<sup>1</sup>

Treatment Type	Product	Total (Gal/Sq)	DFT* (mils)
3-Coursed Rates	Elastuff® 101 and Fabric	4.00	57
Flashing Grade Only Rates	Elastuff® 101	2.00	26

Note: For other product options, please refer to our Seam Treatment Guide.

<sup>1</sup>Flashing rates are based on a 6" (152 mm) width, rates will double for 12" (305 mm) width.

### SMOOTH ASPHALTIC

Coverage Term	Elastuff® 101		Elastuff® 103			Total		Warranties/Guarantees Available	
	Base Coat (Gal/Sq)	DFT* (mils)	1st Coat Gal/Sq	2nd Coat Gal/Sq	DFT* (mils)	Total Gal/Sq	DFT* (mils)	Emerald Pledge™	Diamond Pledge™
10 Year	1.50	19	1.50		14	3.00	33	Yes	No
15 Year	1.50	19	1.00	1.25	21	3.75	40	Yes	No

\* Dry Film Thickness (DFT) is rounded to nearest mil, and is theoretical. Actual DFT will vary dependent on substrate profile, application technique and waste factor.

Note: DFT for 3-coursed rates includes 6 mils for the fabric.

# ELASTUFF® 101 WITH ELASTUFF® 103 QUICK SPEC

## GRANULATED ASPHALTIC (EL-3)

**NOTE:** The following "Quick Spec" is an abbreviated specification and is not meant to replace the detailed specification. Complete 3-part CSI System Specifications are available at [www.gaf.com](http://www.gaf.com).



### METHOD REQUIREMENTS

#### Required:

- Moisture survey required
- Remove and replace any wet areas
- Repair membrane with like materials
- Roof must be clean, dry and tight
- No rain, dew, fog, or freezing temperatures in forecast for 24 hours
- Adhesion test required
- Power washing required

#### Restrictions:

Do not apply over gravel surfaced substrates.

#### Recommendations:

- Refer to Technical Data Sheet for product specific application and surface temperature restrictions.
- New membranes should be aged at least 30 days; 90 + days is ideal.

#### Installation Overview:

1. Before coating is applied, an adhesion test is required to ensure an adhesion minimum of 2.0 pounds per linear inch (PLI). Test patches to be applied with rates listed below.
2. Power-wash substrate to remove contaminants that could negatively affect adhesion. Allow roof to completely dry.
3. Treat "alligatored" areas, surface cracks, roof penetrations, drains, curbs and scuppers. (Refer to Substrate Preparation section for requirements)
4. All loose seams must be 3-coursed. All other seams must be treated with flashing grade only, no fabric required. (Refer to Seam Treatment Guide for requirements)
5. Apply coating per the chart below:

### CLEAN / PRIME

	Product	Rate (Gal/Sq)
Cleaner	UCC Cleaner ( <i>diluted</i> )	0.5 - 0.7
Primer	Not required	

### SEAMS & DETAILS<sup>1</sup>

Treatment Type	Product	Total (Gal/Sq)	DFT* (mils)
3-Coursed Rates	Elastuff® 101 and Fabric	4.00	57
Flashing Grade Only Rates	Elastuff® 101	2.00	26

Note: For other product options, please refer to our Seam Treatment Guide.

<sup>1</sup>Flashing rates are based on a 6" (152 mm) width, rates will double for 12" (305 mm) width.

### GRANULATED ASPHALTIC

Coverage Term	Elastuff® 101		Elastuff® 103			Total		Warranties/Guarantees Available	
	Base Coat (Gal/Sq)	DFT* (mils)	1st Coat Gal/Sq	2nd Coat Gal/Sq	DFT* (mils)	Total Gal/Sq	DFT* (mils)	Emerald Pledge™	Diamond Pledge™
10 Year	1.50	19	1.50		14	3.00	33	Yes	No
15 Year	1.50	19	1.00	1.25	21	3.75	40	Yes	No

\* Dry Film Thickness (DFT) is rounded to nearest mil, and is theoretical. Actual DFT will vary dependent on substrate profile, application technique and waste factor. Note: DFT for 3-coursed rates includes 6 mils for the fabric.

# ELASTUFF® 101 WITH ELASTUFF® 103 QUICK SPEC

## STRUCTURAL CONCRETE (EL-4)

**NOTE:** The following "Quick Spec" is an abbreviated specification and is not meant to replace the detailed specification. Complete 3-part CSI System Specifications are available at [www.gaf.com](http://www.gaf.com).



### METHOD REQUIREMENTS

#### Required:

- Moisture survey required (Must contain less than 8% moisture)
- Repair deteriorated sections with like materials. Allow repairs to cure properly
- Roof must be clean, dry and tight
- No rain, dew, fog, or freezing temperatures in forecast for 24 hours
- Adhesion test required
- Power washing required
- Concrete must be fully cured

#### Recommendations:

- Refer to Technical Data Sheet for product specific application and surface temperature restrictions.

#### Installation Overview:

1. Before coating is applied, an adhesion test is required to ensure an adhesion minimum of 2.0 pounds per linear inch (PLI). Test patches to be applied with rates listed below.
2. Power-wash substrate to remove contaminants that could negatively affect adhesion. Allow roof to completely dry.
3. Prime per chart below.
4. Treat all roof penetrations, drains, curbs, and scuppers. (Refer to Substrate Preparation section for requirements)
5. Treat structural joints with backer rod and compatible sealant prior to seam treatment. (Refer to Seam Treatment Guide for requirements)
6. Control joints in excess of 1/16" (1.6 mm) shall be caulked with compatible caulk.
7. Apply coating per the chart below:

### CLEAN / PRIME

	Product	Rate (Gal/Sq)
Cleaner	UCC Cleaner ( <i>diluted</i> )	0.5 - 0.7
Primer	UniTile LV Sealer	0.20 - 0.25

### SEAMS & DETAILS<sup>1</sup>

Treatment Type	Product	Total (Gal/Sq)	DFT* (mils)
3-Coursed Rates	Elastuff® 101 and Fabric	4.00	57
Flashing Grade Only Rates	Elastuff® 101	2.00	26

Note: For other product options, please refer to our Seam Treatment Guide.

<sup>1</sup>Flashing rates are based on a 6" (152 mm) width, rates will double for 12" (305 mm) width.

### STRUCTURAL CONCRETE

Coverage Term	Elastuff® 101		Elastuff® 103			Total		Warranties/Guarantees Available	
	Base Coat (Gal/Sq)	DFT* (mils)	1st Coat Gal/Sq	2nd Coat Gal/Sq	DFT* (mils)	Total Gal/Sq	DFT* (mils)	Emerald Pledge™	Diamond Pledge™
10 Year	1.50	19	1.50		14	3.00	33	Yes	No
15 Year	1.50	19	1.00	1.25	21	3.75	40	Yes	No

\* Dry Film Thickness (DFT) is rounded to nearest mil, and is theoretical. Actual DFT will vary dependent on substrate profile, application technique and waste factor. Note: DFT for 3-coursed rates includes 6 mils for the fabric.



# ELASTUFF® 101 WITH ELASTUFF® 103 QUICK SPEC

## CORRUGATED STRUCTURAL TRANSITE PANELS (EL-5)

**NOTE:** The following "Quick Spec" is an abbreviated specification and is not meant to replace the detailed specification. Complete 3-part CSI System Specifications are available at [www.gaf.com](http://www.gaf.com).



### METHOD REQUIREMENTS

#### Required:

- Moisture survey required
- Remove and replace any wet areas
- Repair membrane with like materials
- Roof must be clean, dry and tight
- No rain, dew, fog, or freezing temperatures in forecast for 24 hours
- Adhesion test required
- Power washing required

#### Recommendations:

- Refer to Technical Data Sheet for product specific application and surface temperature restrictions.

#### Installation Overview:

1. Before coating is applied, an adhesion test is required to ensure an adhesion minimum of 2.0

2. pounds per linear inch (PLI). Test patches to be applied with rates listed below.
2. Power-wash substrate to remove contaminants that could negatively affect adhesion. Allow roof to completely dry.
3. Tighten/replace existing fasteners. Encapsulate with appropriate flashing material.
4. Prime per chart below.
5. Treat all roof penetrations, drains, curbs, and scuppers. (Refer to Substrate Preparation section for requirements)
6. Treat transite gaps in excess of 1/16" with compatible caulk prior to seam treatment. (Refer to Seam Treatment Guide for requirements)
7. All loose seams must be 3-coursed with flashing grade and fabric. All other seams must be treated with flashing grade only, no fabric required.
8. Apply coating per the chart below:

CLEAN / PRIME		
	Product	Rate (Gal/Sq)
Cleaner	UCC Cleaner (diluted)	0.5 - 0.7
Primer	UniTile LV Sealer	0.20 - 0.25

SEAMS & DETAILS <sup>1</sup>			
Treatment Type	Product	Total (Gal/Sq)	DFT* (mils)
3-Coursed Rates	Elastuff® 101 and Fabric	4.00	57
Flashing Grade Only Rates	Elastuff® 101	2.00	26

Note: For other product options, please refer to our Seam Treatment Guide.  
<sup>1</sup>Flashing rates are based on a 6" (152 mm) width, rates will double for 12" (305 mm) width.

### CORRUGATED STRUCTURAL TRANSITE PANELS

Coverage Term	Elastuff® 101		Elastuff® 103			Total		Warranties/Guarantees Available	
	Base Coat (Gal/Sq)	DFT* (mils)	1st Coat Gal/Sq	2nd Coat Gal/Sq	DFT* (mils)	Total Gal/Sq	DFT* (mils)	Emerald Pledge™	Diamond Pledge™
10 Year	1.50	19	1.50		14	3.00	33	Yes	No
15 Year	1.50	19	1.00	1.25	21	3.75	40	Yes	No

\* Dry Film Thickness (DFT) is rounded to nearest mil, and is theoretical. Actual DFT will vary dependent on substrate profile, application technique and waste factor.

Note: DFT for 3-coursed rates includes 6 mils for the fabric.

**Important Note:** Corrugated transite panels may contain asbestos. Follow all local, state and federal regulations concerning asbestos. Under no circumstances does GAF have any liability for any damages, costs or expenses arising out of or associated with the pre-existing presence of asbestos containing materials or any other allegedly hazardous substances or materials upon the roof to which the new GAF roofing materials are being applied.

# ELASTUFF® 101 WITH ELASTUFF® 103 QUICK SPEC

## SPRAY POLYURETHANE FOAM (EL-6)

**NOTE:** The following “Quick Spec” is an abbreviated specification and is not meant to replace the detailed specification. Complete 3-part CSI System Specifications are available at [www.gaf.com](http://www.gaf.com).



### METHOD REQUIREMENTS

#### Required:

- Moisture survey required
- Remove and replace any wet areas
- Repair membrane with like materials
- Roof must be clean, dry and tight
- No rain, dew, fog, or freezing temperatures in forecast for 24 hours
- Adhesion test required
- Power washing required

#### Recommendations:

- Refer to Technical Data Sheet for product specific application and surface temperature restrictions.

#### Installation Overview:

1. Before coating is applied, an adhesion test is required to ensure an adhesion minimum of 2.0 pounds per linear inch (PLI). Test patches to be applied with rates listed below.
2. Power-wash substrate to remove contaminants that could negatively affect adhesion. Allow roof to completely dry.
3. Treat all roof penetrations, drains, curbs, and scuppers. (Refer to Substrate Preparation section for requirements)
4. Apply coating per the chart below:

### CLEAN / PRIME

	Product	Rate (Gal/Sq)
Cleaner	UCC Cleaner ( <i>diluted</i> )	0.5 - 0.7
Primer	Not required	

### SEAMS & DETAILS<sup>1</sup>

Treatment Type	Product	Total (Gal/Sq)	DFT* (mils)
3-Coursed Rates	Elastuff® 101 and Fabric	4.00	57
Flashing Grade Only Rates	Elastuff® 101	2.00	26

Note: For other product options, please refer to our Seam Treatment Guide.

<sup>1</sup>Flashing rates are based on a 6" (152 mm) width, rates will double for 12" (305 mm) width.

### SPRAY POLYURETHANE FOAM

Coverage Term	Elastuff® 101		Elastuff® 103			Total		Warranties/Guarantees Available	
	Base Coat (Gal/Sq)	DFT* (mils)	1st Coat Gal/Sq	2nd Coat Gal/Sq	DFT* (mils)	Total Gal/Sq	DFT* (mils)	Emerald Pledge™	Diamond Pledge™
10 Year	1.50	19	1.50		14	3.00	33	Yes	No
15 Year	1.50	19	1.00	1.25	21	3.75	40	Yes	No

\* Dry Film Thickness (DFT) is rounded to nearest mil, and is theoretical. Actual DFT will vary dependent on substrate profile, application technique and waste factor. Note: DFT for 3-coursed rates includes 6 mils for the fabric.

## SURFACE SEAL SB QUICK SPEC DIRECTORY

Spec Number	Substrate Specification	Page #
SS-1	Surface Seal SB over Metal	67
SS-2	Surface Seal SB over EPDM	68
SS-3	Surface Seal SB over Smooth Asphaltic	69
SS-4	Surface Seal SB over Granulated Asphaltic	70
SS-5	Surface Seal SB over Structural Concrete	71

*Quick Specs are abbreviated specifications and are not meant to replace detailed specifications. Complete 3-part CSI System Specifications are available at [www.gaf.com](http://www.gaf.com).*

# SURFACE SEAL SB QUICK SPEC

## METAL (SS-1)

**NOTE:** The following "Quick Spec" is an abbreviated specification and is not meant to replace the detailed specification. Complete 3-part CSI System Specifications are available at [www.gaf.com](http://www.gaf.com).



### METHOD REQUIREMENTS

#### Required:

- Roof must be clean, dry and tight
- No rain, dew, fog, or freezing temperatures in forecast for 24 hours
- Adhesion test required
- Power washing required

#### Recommendations:

- Refer to Technical Data Sheet for product specific application and surface temperature restrictions.
- Rust should be removed with a wire brush prior to coating, and structural repairs should be made with like-materials as needed.

#### Installation Overview:

1. Before coating is applied, an adhesion test is required to ensure an adhesion minimum of 2.0

2. Tighten/replace existing fasteners. Encapsulate with appropriate flashing material.
3. Power-wash substrate to remove contaminants that could negatively affect adhesion. Allow roof to completely dry.
4. Install crickets to divert water and complete other necessary sheet metal repairs.
5. Prime per chart below.
6. Treat all roof penetrations, drains, curbs, and scuppers. (Refer to Substrate Preparation section for requirements)
7. Horizontal seams must be 3-coursed. Overlap and trapezoidal vertical seams must be treated with flashing grade only. Other vertical seams may forgo treatment **IF** the seal/tape is intact on the seam or if they are double locked. (Refer to Seam Treatment Guide for requirements)
8. Apply coating per the chart below:

### CLEAN / PRIME

Product	Rate (Gal/Sq)	
Cleaner	UCC Cleaner ( <i>diluted</i> )	0.5 - 0.7
Primer	Lock-Down Primer	0.33 - 0.40

### SEAMS & DETAILS<sup>1</sup>

Treatment Type	Product	Total (Gal/Sq)	DFT* (mils)
3-Coursed Rates	FlexSeal™ and Fabric	4.00	48
Flashing Grade Only Rates	FlexSeal™ Flashing	2.00	21

Note: For other product options, please refer to our Seam Treatment Guide.

<sup>1</sup>Flashing rates are based on a 6" (152 mm) width, rates will double for 12" (305 mm) width.

### METAL

Coverage Term	Coating			Total		Warranties/Guarantees Available	
	1st Coat Gal/Sq	2nd Coat Gal/Sq	3rd Coat Gal/Sq	Gal/Sq	DFT* (mils)	Emerald Pledge™	Diamond Pledge™
10 Year	1.00	1.50		2.50	20	Yes	Yes
15 Year	1.00	1.50	1.00	3.50	28	Yes	Yes
20 Year	1.50	1.50	1.50	4.50	36	Yes	Yes

\* Dry Film Thickness (DFT) is rounded to nearest mil, and is theoretical. Actual DFT will vary dependent on substrate profile, application technique and waste factor.

Note: DFT for 3-coursed rates includes 6 mils for the fabric.

# SURFACE SEAL SB QUICK SPEC

## EPDM (SS-2)

**NOTE:** The following "Quick Spec" is an abbreviated specification and is not meant to replace the detailed specification. Complete 3-part CSI System Specifications are available at [www.gaf.com](http://www.gaf.com).



### METHOD REQUIREMENTS

#### Required:

- Moisture survey required
- Remove and replace any wet areas
- Repair membrane with like materials
- Roof must be clean, dry and tight
- No rain, dew, fog, or freezing temperatures in forecast for 24 hours
- Adhesion test required
- Power washing required

#### Recommendations:

- Refer to Technical Data Sheet for product specific application and surface temperature restrictions.

#### Installation Overview:

1. Before coating is applied, an adhesion test is required to ensure an adhesion minimum of 2.0 pounds per linear inch (PLI). Test patches to be applied with rates listed below.
2. Power-wash substrate to remove contaminants that could negatively affect adhesion. Allow roof to completely dry.
3. Prime per chart below.
4. Treat all roof penetrations, drains, curbs, and scuppers. (Refer to Substrate Preparation section for requirements)
5. All loose seams must be 3-coursed. All other seams must be treated with flashing grade only, no fabric required. (Refer to Seam Treatment Guide for requirements)
6. Apply coating per the chart below:

### CLEAN / PRIME

	Product	Rate (Gal/Sq)
Cleaner	UCC Cleaner ( <i>diluted</i> )	0.5 - 0.7
Primer	CleanAct Rinsable Primer	0.50 - 0.67

### SEAMS & DETAILS<sup>1</sup>

Treatment Type	Product	Total (Gal/Sq)	DFT* (mils)
3-Coursed Rates	FlexSeal™ and Fabric	4.00	48
Flashing Grade Only Rates	FlexSeal™ Flashing	2.00	21

Note: For other product options, please refer to our Seam Treatment Guide.

<sup>1</sup>Flashing rates are based on a 6" (152 mm) width, rates will double for 12" (305 mm) width.

### EPDM

Coverage Term	Coating			Total		Warranties/Guarantees Available	
	1st Coat Gal/Sq	2nd Coat Gal/Sq	3rd Coat Gal/Sq	Gal/Sq	DFT* (mils)	Emerald Pledge™	Diamond Pledge™
10 Year	1.25	1.50		2.75	22	Yes	No
15 Year	1.25	1.50	1.00	3.75	30	Yes	No

\* Dry Film Thickness (DFT) is rounded to nearest mil, and is theoretical. Actual DFT will vary dependent on substrate profile, application technique and waste factor.

Note: DFT for 3-coursed rates includes 6 mils for the fabric.

# SURFACE SEAL SB QUICK SPEC

## SMOOTH ASPHALTIC (SS-3)

**NOTE:** The following "Quick Spec" is an abbreviated specification and is not meant to replace the detailed specification. Complete 3-part CSI System Specifications are available at [www.gaf.com](http://www.gaf.com).



### METHOD REQUIREMENTS

#### Required:

- Moisture survey required
- Remove and replace any wet areas
- Repair membrane with like materials
- Roof must be clean, dry and tight
- No rain, dew, fog, or freezing temperatures in forecast for 24 hours
- Adhesion test required
- Power washing required

#### Restrictions:

Do not apply over gravel surfaced substrates.

#### Recommendations:

- Refer to Technical Data Sheet for product specific application and surface temperature restrictions.
- New membranes should be aged at least 30 days; 90+ days is ideal.

#### Installation Overview:

1. Before coating is applied, an adhesion test is required to ensure an adhesion minimum of 2.0 pounds per linear inch (PLI). Test patches to be applied with rates listed below.
2. Power-wash substrate to remove contaminants that could negatively affect adhesion. Allow roof to completely dry.
3. Prime per chart below.
4. Treat "alligatored" areas, surface cracks, roof penetrations, drains, curbs and scuppers. (Refer to Substrate Preparation section for requirements)
5. All loose seams must be 3-coursed. All other seams must be treated with flashing grade only, no fabric required. (Refer to Seam Treatment Guide for requirements)
6. Apply coating per the chart below:

### CLEAN / PRIME

	Product	Rate (Gal/Sq)
Cleaner	UCC Cleaner (diluted)	0.5 - 0.7
Primer	Unisil Primer	0.67 - 1.00

### SEAMS & DETAILS<sup>1</sup>

Treatment Type	Product	Total (Gal/Sq)	DFT* (mils)
3-Coursed Rates	FlexSeal™ and Fabric	4.00	48
Flashing Grade Only Rates	FlexSeal™ Flashing	2.00	21

Note: For other product options, please refer to our Seam Treatment Guide.

<sup>1</sup>Flashing rates are based on a 6" (152 mm) width, rates will double for 12" (305 mm) width.

### SMOOTH ASPHALTIC

Coverage Term	Coating			Total		Warranties/Guarantees Available	
	1st Coat Gal/Sq	2nd Coat Gal/Sq	3rd Coat Gal/Sq	Gal/Sq	DFT* (mils)	Emerald Pledge™	Diamond Pledge™
10 Year	1.50	1.50		3.00	24	Yes	No
15 Year	1.50	1.50	1.00	4.00	32	Yes	No

\* Dry Film Thickness (DFT) is rounded to nearest mil, and is theoretical. Actual DFT will vary dependent on substrate profile, application technique and waste factor.

Note: DFT for 3-coursed rates includes 6 mils for the fabric.

# SURFACE SEAL SB QUICK SPEC

## GRANULATED ASPHALTIC (SS-4)

**NOTE:** The following "Quick Spec" is an abbreviated specification and is not meant to replace the detailed specification. Complete 3-part CSI System Specifications are available at [www.gaf.com](http://www.gaf.com).



### METHOD REQUIREMENTS

#### Required:

- Moisture survey required
- Remove and replace any wet areas
- Repair membrane with like materials
- Roof must be clean, dry and tight
- No rain, dew, fog, or freezing temperatures in forecast for 24 hours
- Adhesion test required
- Power washing required

#### Restrictions:

Do not apply over gravel surfaced substrates.

#### Recommendations:

- Refer to Technical Data Sheet for product specific application and surface temperature restrictions.
- New membranes should be aged at least 30 days; 90 + days is ideal.

#### Installation Overview:

1. Before coating is applied, an adhesion test is required to ensure an adhesion minimum of 2.0 pounds per linear inch (PLI). Test patches to be applied with rates listed below.
2. Power-wash substrate to remove contaminants that could negatively affect adhesion. Allow roof to completely dry.
3. Prime per chart below.
4. Treat "alligatored" areas, surface cracks, roof penetrations, drains, curbs and scuppers. (Refer to Substrate Preparation section for requirements)
5. All loose seams must be 3-coursed. All other seams must be treated with flashing grade only, no fabric required. (Refer to Seam Treatment Guide for requirements)
6. Apply coating per the chart below:

### CLEAN / PRIME

	Product	Rate (Gal/Sq)
Cleaner	UCC Cleaner (diluted)	0.5 - 0.7
Primer	Unisil Primer	1.00 - 1.33

### SEAMS & DETAILS<sup>1</sup>

Treatment Type	Product	Total (Gal/Sq)	DFT* (mils)
3-Coursed Rates	FlexSeal™ and Fabric	4.00	48
Flashing Grade Only Rates	FlexSeal™ Flashing	2.00	21

Note: For other product options, please refer to our Seam Treatment Guide.

<sup>1</sup>Flashing rates are based on a 6" (152 mm) width, rates will double for 12" (305 mm) width.

### GRANULATED ASPHALTIC

Coverage Term	Coating			Total		Warranties/Guarantees Available	
	1st Coat Gal/Sq	2nd Coat Gal/Sq	3rd Coat Gal/Sq	Gal/Sq	DFT* (mils)	Emerald Pledge™	Diamond Pledge™
10 Year	1.50	1.50		3.00	24	Yes	No
15 Year	1.50	1.50	1.00	4.00	32	Yes	No

\* Dry Film Thickness (DFT) is rounded to nearest mil, and is theoretical. Actual DFT will vary dependent on substrate profile, application technique and waste factor.

Note: DFT for 3-coursed rates includes 6 mils for the fabric.

# SURFACE SEAL SB QUICK SPEC

## STRUCTURAL CONCRETE (SS-5)

**NOTE:** The following “Quick Spec” is an abbreviated specification and is not meant to replace the detailed specification. Complete 3-part CSI System Specifications are available at [www.gaf.com](http://www.gaf.com).



### METHOD REQUIREMENTS

#### Required:

- Moisture survey required (Must contain less than 8% moisture)
- Repair deteriorated sections with like materials. Allow repairs to cure properly
- Roof must be clean, dry and tight
- No rain, dew, fog, or freezing temperatures in forecast for 24 hours
- Adhesion test required
- Power washing required
- Concrete must be fully cured

#### Recommendations:

- Refer to Technical Data Sheet for product specific application and surface temperature restrictions.

#### Installation Overview:

1. Before coating is applied, an adhesion test is required to ensure an adhesion minimum of 2.0 pounds per linear inch (PLI). Test patches to be applied with rates listed below.
2. Power-wash substrate to remove contaminants that could negatively affect adhesion. Allow roof to completely dry.
3. Prime per chart below.
4. Treat all roof penetrations, drains, curbs, and scuppers. (Refer to Substrate Preparation section for requirements)
5. Treat structural joints with backer rod and compatible sealant prior to seam treatment. (Refer to Seam Treatment Guide for requirements)
6. Control joints in excess of 1/16" (1.6 mm) shall be caulked with compatible caulk.
7. Apply coating per the chart below:

### CLEAN / PRIME

	Product	Rate (Gal/Sq)
Cleaner	UCC Cleaner ( <i>diluted</i> )	0.5 - 0.7
Primer	UniTile LV Sealer	0.20 - 0.25

### SEAMS & DETAILS<sup>1</sup>

Treatment Type	Product	Total (Gal/Sq)	DFT* (mils)
3-Coursed Rates	FlexSeal™ and Fabric	4.00	48
Flashing Grade Only Rates	FlexSeal™ Flashing	2.00	21

Note: For other product options, please refer to our Seam Treatment Guide.

<sup>1</sup>Flashing rates are based on a 6" (152 mm) width, rates will double for 12" (305 mm) width.

### STRUCTURAL CONCRETE

Coverage Term	Coating			Total		Warranties/Guarantees Available	
	1st Coat Gal/Sq	2nd Coat Gal/Sq	3rd Coat Gal/Sq	Gal/Sq	DFT* (mils)	Emerald Pledge™	Diamond Pledge™
10 Year	1.50	1.50		3.00	24	Yes	No
15 Year	1.50	1.50	1.00	4.00	32	Yes	No

\* Dry Film Thickness (DFT) is rounded to nearest mil, and is theoretical. Actual DFT will vary dependent on substrate profile, application technique and waste factor.

Note: DFT for 3-coursed rates includes 6 mils for the fabric.



## DIATHON® QUICK SPEC DIRECTORY

Spec Number	Substrate Specification	Page #
DT-1	Diathon® over Spray Polyurethane Foam	73

*Quick Specs are abbreviated specifications and are not meant to replace detailed specifications. Complete 3-part CSI System Specifications are available at [www.gaf.com](http://www.gaf.com).*

# DIATHON® QUICK SPEC

## SPRAY POLYURETHANE FOAM (DT-1)

**NOTE:** The following "Quick Spec" is an abbreviated specification and is not meant to replace the detailed specification. Complete 3-part CSI System Specifications are available at [www.gaf.com](http://www.gaf.com).



### METHOD REQUIREMENTS

#### Required:

- Moisture survey required
- Remove and replace any wet areas
- Repair membrane with like materials
- Roof must be clean, dry and tight
- No rain, dew, fog, or freezing temperatures in forecast for 24 hours
- Adhesion test required
- Power washing required

#### Recommendations:

- Refer to Technical Data Sheet for product specific application and surface temperature restrictions.

#### Installation Overview:

1. Before coating is applied, an adhesion test is required to ensure an adhesion minimum of 2.0 pounds per linear inch (PLI). Test patches to be applied with rates listed below.
2. Power-wash substrate to remove contaminants that could negatively affect adhesion. Allow roof to completely dry.
3. Treat all roof penetrations, drains, curbs, and scuppers. (Refer to Substrate Preparation section for requirements)
4. Apply coating per the chart below:

### CLEAN / PRIME

	Product	Rate (Gal/Sq)
Cleaner	UCC Cleaner (diluted)	0.5 - 0.7
Primer	Not required	

### SEAMS & DETAILS<sup>1</sup>

Treatment Type	Product	Total (Gal/Sq)	DFT* (mils)
3-Coursed Rates	Roof Mate™ Butter Grade and Fabric	4.00	43

Note: For other product options, please refer to our Seam Treatment Guide.

<sup>1</sup>Flashing rates are based on a 6" (152 mm) width, rates will double for 12" (305 mm) width.

### SPRAY POLYURETHANE FOAM

Coverage Term	Base Coat		Coating			Total		Warranties/Guarantees Available		
	Product	Base (Gal/Sq)	Produce (Choose one)	1st Coat Gal/Sq	2nd Coat Gal/Sq	3rd Coat Gal/Sq	Gal/Sq	DFT* (mils)	Emerald Pledge™	Diamond Pledge™
10 Year	Diathon® Base	1.50	Diathon® Diathon® QS	1.50	1.00		4.00	34	Yes	No
			Diathon® HT	1.50	1.00		4.00	33		
15 Year	Diathon® Base	1.50	Diathon® Diathon® QS	1.50	1.00	1.00	5.00	43	Yes	No
			Diathon® HT	1.50	1.00	1.00	5.00	42		
20 Year	Diathon® Base	1.50	Diathon® Diathon® QS	1.50	1.50	1.50	6.00	51	Yes	No
			Diathon® HT	1.50	1.50	1.50	6.00	50		

\* Dry Film Thickness (DFT) is rounded to nearest mil, and is theoretical. Actual DFT will vary dependent on substrate profile, application technique and waste factor. Note: DFT for 3-coursed rates includes 6 mils for the fabric.

## KYMAX + UNITED COATINGS™ QUICK SPEC DIRECTORY

Spec Number	Substrate Specification	Page #
KM-1	Roof Mate™ and Kymax™ over Metal	75
KM-2	Roof Mate™ and Kymax™ over TPO	76
KM-3	Roof Mate™ and Kymax™ over PVC	77
KM-4	Roof Mate™ and Kymax™ over Hypalon®	78
KM-5	Roof Mate™ and Kymax™ over EPDM	79
KM-6	Roof Mate™ and Kymax™ over Smooth & Granulated Asphaltic	80
KM-7	Roof Mate™ and Kymax™ over Structural Concrete & Corrugated Structural Transite Panels	81
KM-8	Kymax™ Logo Work	82
KM-9	Kymax™ Metal Restoration	83

*Quick Specs are abbreviated specifications and are not meant to replace detailed specifications. Complete 3-part CSI System Specifications are available at [www.gaf.com](http://www.gaf.com).*

# Roof Mate™ + KYMAX™ QUICK SPEC

## METAL (KM-1)

**NOTE:** The following “Quick Spec” is an abbreviated specification and is not meant to replace the detailed specification. Complete 3-part CSI System Specifications are available at [www.gaf.com](http://www.gaf.com).



### METHOD REQUIREMENTS

#### Required:

- Roof must be clean, dry and tight
- No rain, dew, fog or freezing temperatures in forecast for 24 hours
- Adhesion test required
- Power washing required

#### Recommendations:

- Refer to Technical Data Sheet for product specific application and surface temperature restrictions.
- Rust should be removed with a wire brush prior to coating, and structural repairs should be made with like-materials as needed.

#### Installation Overview:

1. Before coating is applied, an adhesion test is required to ensure an adhesion minimum of 2.0

pounds per linear inch (PLI). Test patches to be applied with rates listed below.

2. Tighten/replace existing fasteners. Encapsulate with appropriate flashing material.
3. Power-wash substrate to remove contaminants that could negatively affect adhesion. Allow roof to completely dry.
4. Install crickets to divert water and complete other necessary sheet metal repairs.
5. Prime rusty areas per chart below.
6. Treat all roof penetrations, drains, curbs, and scuppers. (Refer to Substrate Preparation section for requirements)
7. Horizontal seams must be 3-coursed. Overlap and trapezoidal vertical seams must be treated with flashing grade only. Other vertical seams may forgo treatment **IF** the seal/tape is intact on the seam or if they are double locked. (Refer to Seam Treatment Guide for requirements)
8. Apply coating per the chart below:

#### CLEAN / PRIME

	Product	Rate (Gal/Sq)
Cleaner	UCC Cleaner	0.5 - 0.7
Primer (rusty areas)	Acrylex 400	0.30 - 0.50
Primer (severe rust)	Lock-Down Primer	0.25 - 0.33

#### SEAMS & DETAILS<sup>1</sup>

Treatment Type	Product	Total (Gal/Sq)	DFT* (mils)
3-Coursed Rates	Roof Mate™ Butter Grade and Fabric	4.0	43
Flashing Grade Only Rates	Roof Mate™ Butter Grade	2.0	19

Note: For other product options, please refer to our Seam Treatment Guide.

<sup>1</sup>Flashing rates are based on a 6" (152 mm) width, rates will double for 12" (305 mm) width.

### METAL

Coverage Term	Roof Mate™						Kymax™				Total		Warranties/ Guarantees Available+	
	Product (Choose one)	1st Coat (Gal/Sq)	2nd Coat (Gal/Sq)	3rd Coat (Gal/Sq)	Total (Gal/Sq)	DFT* (mils)	1st Coat (Gal/Sq)	2nd Coat (Gal/Sq)	Total (Gal/Sq)	DFT* (mils)	Total Gal/Sq	DFT* (mils)	Emerald Pledge™	Diamond Pledge™
15 Year+	Roof Mate™	1.00	1.50		2.50	21	0.40	0.40	0.80	4.50	3.30	25.50	Yes	Yes
	Roof Mate™ QS	1.00	1.50		2.50	21					3.30	25.50		
	Roof Mate™ HT	1.00	1.50		2.50	21					3.30	25.50		
	Roof Mate™ TCM	1.00	1.00		2.00	19					2.80	23.50		
20 Year+	Roof Mate™	1.00	1.50	1.00	3.50	30	0.40	0.40	0.80	4.50	4.30	34.50	Yes	Yes
	Roof Mate™ QS	1.00	1.50	1.00	3.50	30					4.30	34.50		
	Roof Mate™ HT	1.00	1.50	1.00	3.50	29					4.30	33.50		
	Roof Mate™ TCM	1.50	1.75		3.25	30					4.05	34.50		

\* Dry Film Thickness (DFT) is rounded to nearest mil, and is theoretical. Actual DFT will vary dependent on substrate profile, application technique and waste factor. Note: DFT for 3-coursed rates includes 6 mils for the fabric. +Eligible for 10 Year Extended Limited Warranty (color).

# Roof Mate™ + KYMAX™ QUICK SPEC

## TPO (KM-2)

**NOTE:** The following “Quick Spec” is an abbreviated specification and is not meant to replace the detailed specification. Complete 3-part CSI System Specifications are available at [www.gaf.com](http://www.gaf.com).



### METHOD REQUIREMENTS

#### Required:

- Moisture survey required
- Remove and replace any wet areas
- Repair membrane with like materials
- Roof must be clean, dry and tight
- No rain, dew, fog, or freezing temperatures in forecast for 24 hours
- Adhesion test required
- Power washing required

#### Recommendations:

- Refer to Technical Data Sheet for product specific application and surface temperature restrictions.

#### Installation Overview:

1. Before coating is applied, an adhesion test is required to ensure an adhesion minimum of 2.0 pounds per linear inch (PLI). Test patches to be applied with rates listed below.
2. Power-wash substrate to remove contaminants that could negatively affect adhesion. Allow roof to completely dry.
3. Prime per chart below.
4. Treat all roof penetrations, drains, curbs, and scuppers. (Refer to Substrate Preparation section for requirements)
5. All loose seams must be 3-coursed. All other seams must be treated with flashing grade only, no fabric required. (Refer to Seam Treatment Guide for requirements)
6. Apply coating per the chart below:

#### CLEAN / PRIME

	Product	Rate (Gal/Sq)
Cleaner	UCC Cleaner	0.5 - 0.7
Primer	TPO Red Primer	0.25

#### SEAMS & DETAILS<sup>1</sup>

Treatment Type	Product	Total (Gal/Sq)	DFT* (mils)
3-Coursed Rates	Roof Mate™ Butter Grade and Fabric	4.0	43
Flashing Grade Only Rates	Roof Mate™ Butter Grade	2.0	19

Note: For other product options, please refer to our Seam Treatment Guide.

<sup>1</sup>Flashing rates are based on a 6" (152 mm) width, rates will double for 12" (305 mm) width.

### TPO

Coverage Term	Roof Mate™					Kymax™				Total		Warranties/Guarantees Available+	
	Product (Choose one)	1st Coat (Gal/Sq)	2nd Coat (Gal/Sq)	Total (Gal/Sq)	DFT* (mils)	1st Coat (Gal/Sq)	2nd Coat (Gal/Sq)	Total (Gal/Sq)	DFT* (mils)	Total Gal/Sq	DFT* (mils)	Emerald Pledge™	Diamond Pledge™
15 Year+	Roof Mate™	1.50	1.50	3.00	25	0.40	0.40	0.80	4.50	3.80	29.50	Yes	No
	Roof Mate™ QS	1.50	1.50	3.00	25					3.80	29.50		
	Roof Mate™ HT	1.50	1.50	3.00	25					3.80	29.50		
	Roof Mate™ TCM	1.00	1.50	2.50	23					3.30	27.50		

\* Dry Film Thickness (DFT) is rounded to nearest mil, and is theoretical. Actual DFT will vary dependent on substrate profile, application technique and waste factor.

Note: DFT for 3-coursed rates includes 6 mils for the fabric.

+Eligible for 10 Year Extended Limited Warranty (color).

# Roof Mate™ + KYMAX™ QUICK SPEC

## PVC (KM-3)

**NOTE:** The following "Quick Spec" is an abbreviated specification and is not meant to replace the detailed specification. Complete 3-part CSI System Specifications are available at [www.gaf.com](http://www.gaf.com).



### METHOD REQUIREMENTS

#### Required:

- Moisture survey required
- Remove and replace any wet areas
- Repair membrane with like materials
- Roof must be clean, dry and tight
- No rain, dew, fog, or freezing temperatures in forecast for 24 hours
- Adhesion test required
- Power washing required

#### Recommendations:

- Refer to Technical Data Sheet for product specific application and surface temperature restrictions.

#### Installation Overview:

1. Before coating is applied, an adhesion test is required to ensure an adhesion minimum of 2.0 pounds per linear inch (PLI). Test patches to be applied with rates listed below.
2. Power-wash substrate to remove contaminants that could negatively affect adhesion. Allow roof to completely dry.
3. Prime per chart below.
4. Treat all roof penetrations, drains, curbs, and scuppers. (Refer to Substrate Preparation section for requirements)
5. All loose seams must be 3-coursed. All other seams must be treated with flashing grade only, no fabric required. (Refer to Seam Treatment Guide for requirements)
6. Apply coating per the chart below:

#### CLEAN / PRIME

	Product	Rate (Gal/Sq)
Cleaner	UCC Cleaner	0.5 - 0.7
Primer	Unisil	0.33

#### SEAMS & DETAILS<sup>1</sup>

Treatment Type	Product	Total (Gal/Sq)	DFT* (mils)
3-Coursed Rates	Roof Mate™ Butter Grade and Fabric	4.0	43
Flashing Grade Only Rates	Roof Mate™ Butter Grade	2.0	19

Note: For other product options, please refer to our Seam Treatment Guide.  
<sup>1</sup>Flashing rates are based on a 6" (152 mm) width, rates will double for 12" (305 mm) width.

### PVC

Coverage Term	Roof Mate™					Kymax™				Total		Warranties/Guarantees Available+	
	Product (Choose one)	1st Coat (Gal/Sq)	2nd Coat (Gal/Sq)	Total (Gal/Sq)	DFT* (mils)	1st Coat (Gal/Sq)	2nd Coat (Gal/Sq)	Total (Gal/Sq)	DFT* (mils)	Total Gal/Sq	DFT* (mils)	Emerald Pledge™	Diamond Pledge™
15 Year+	Roof Mate™	1.50	1.50	3.00	25	0.40	0.40	0.80	4.50	3.80	29.50	Yes	No
	Roof Mate™ QS	1.50	1.50	3.00	25					3.80	29.50		
	Roof Mate™ HT	1.50	1.50	3.00	25					3.80	29.50		
	Roof Mate™ TCM	1.00	1.50	2.50	23					3.30	27.50		

\* Dry Film Thickness (DFT) is rounded to nearest mil, and is theoretical. Actual DFT will vary dependent on substrate profile, application technique and waste factor.

Note: DFT for 3-coursed rates includes 6 mils for the fabric.

+Eligible for 10 Year Extended Limited Warranty (color).

# Roof Mate™ + KYMAX™ QUICK SPEC

## Hypalon® (KM-4)

**NOTE:** The following “Quick Spec” is an abbreviated specification and is not meant to replace the detailed specification. Complete 3-part CSI System Specifications are available at [www.gaf.com](http://www.gaf.com).



### METHOD REQUIREMENTS

#### Required:

- Moisture survey required
- Remove and replace any wet areas
- Repair membrane with like materials
- Roof must be clean, dry and tight
- No rain, dew, fog, or freezing temperatures in forecast for 24 hours
- Adhesion test required
- Power washing required

#### Recommendations:

- Refer to Technical Data Sheet for product specific application and surface temperature restrictions.

#### Installation Overview:

1. Before coating is applied, an adhesion test is required to ensure an adhesion minimum of 2.0 pounds per linear inch (PLI). Test patches to be applied with rates listed below.
2. Power-wash substrate to remove contaminants that could negatively affect adhesion. Allow roof to completely dry.
3. Treat all roof penetrations, drains, curbs, and scuppers. (Refer to Substrate Preparation section for requirements)
4. All loose seams must be 3-coursed. All other seams must be treated with flashing grade only, no fabric required. (Refer to Seam Treatment Guide for requirements)
5. Apply coating per the chart below:

#### CLEAN / PRIME

	Product	Rate (Gal/Sq)
Cleaner	UCC Cleaner	0.5 - 0.7
Primer	Not required	

#### SEAMS & DETAILS<sup>1</sup>

Treatment Type	Product	Total (Gal/Sq)	DFT* (mils)
3-Coursed Rates	Roof Mate™ Butter Grade and Fabric	4.0	43
Flashing Grade Only Rates	Roof Mate™ Butter Grade	2.0	19

Note: For other product options, please refer to our Seam Treatment Guide.  
<sup>1</sup>Flashing rates are based on a 6" (152 mm) width, rates will double for 12" (305 mm) width.

### HYPALON®

Coverage Term	Roof Mate™					Kymax™				Total		Warranties/Guarantees Available <sup>+</sup>	
	Product (Choose one)	1st Coat (Gal/Sq)	2nd Coat (Gal/Sq)	Total (Gal/Sq)	DFT* (mils)	1st Coat (Gal/Sq)	2nd Coat (Gal/Sq)	Total (Gal/Sq)	DFT* (mils)	Total Gal/Sq	DFT* (mils)	Emerald Pledge™	Diamond Pledge™
15 Year+	Roof Mate™	1.50	1.50	3.00	25	0.40	0.40	0.80	4.50	3.80	29.50	Yes	No
	Roof Mate™ QS	1.50	1.50	3.00	25					3.80	29.50		
	Roof Mate™ HT	1.50	1.50	3.00	25					3.80	29.50		
	Roof Mate™ TCM	1.00	1.50	2.50	23					3.30	27.50		

\* Dry Film Thickness (DFT) is rounded to nearest mil, and is theoretical. Actual DFT will vary dependent on substrate profile, application technique and waste factor.

Note: DFT for 3-coursed rates includes 6 mils for the fabric.

<sup>+</sup>Eligible for 10 Year Extended Limited Warranty (color).

# Roof Mate™ + KYMAX™ QUICK SPEC

## EPDM (KM-5)

**NOTE:** The following “Quick Spec” is an abbreviated specification and is not meant to replace the detailed specification. Complete 3-part CSI System Specifications are available at [www.gaf.com](http://www.gaf.com).



### METHOD REQUIREMENTS

#### Required:

- Moisture survey required
- Remove and replace any wet areas
- Repair membrane with like materials
- Roof must be clean, dry and tight
- No rain, dew, fog, or freezing temperatures in forecast for 24 hours
- Adhesion test required
- Power washing required

#### Recommendations:

- Refer to Technical Data Sheet for product specific application and surface temperature restrictions.

#### Instructions:

1. Before coating is applied, an adhesion test is required to ensure an adhesion minimum of 2.0 pounds per linear inch (PLI). Test patches to be applied with rates listed below.
2. Power-wash substrate to remove contaminants that could negatively affect adhesion. Allow roof to completely dry.
3. Prime per chart below.
4. Treat all roof penetrations, drains, curbs, and scuppers. (Refer to Substrate Preparation section for requirements)
5. All loose seams must be 3-coursed. All other seams must be treated with flashing grade only, no fabric required. (Refer to Seam Treatment Guide for requirements)
6. Apply coating per the chart below:

CLEAN / PRIME		
	Product	Rate (Gal/Sq)
Cleaner	UCC Cleaner	0.5 - 0.7
Primer	CleanAct Rinsable Primer	0.20

SEAMS & DETAILS <sup>1</sup>			
Treatment Type	Product	Total (Gal/Sq)	DFT* (mils)
3-Coursed Rates	Roof Mate™ Butter Grade and Fabric	4.0	43
Flashing Grade Only Rates	Roof Mate™ Butter Grade	2.0	19

Note: For other product options, please refer to our Seam Treatment Guide.  
<sup>1</sup>Flashing rates are based on a 6" (152 mm) width, rates will double for 12" (305 mm) width.

EPDM													
Coverage Term	Roof Mate™					Kymax™				Total		Warranties/Guarantees Available+	
	Product (Choose one)	1st Coat (Gal/Sq)	2nd Coat (Gal/Sq)	Total (Gal/Sq)	DFT* (mils)	1st Coat (Gal/Sq)	2nd Coat (Gal/Sq)	Total (Gal/Sq)	DFT* (mils)	Total Gal/Sq	DFT* (mils)	Emerald Pledge™	Diamond Pledge™
15 Year+	Roof Mate™	1.50	1.50	3.00	25	0.40	0.40	0.80	4.50	3.80	29.50	Yes	No
	Roof Mate™ QS	1.50	1.50	3.00	25					3.80	29.50		
	Roof Mate™ HT	1.50	1.50	3.00	25					3.80	29.50		
	Roof Mate™ TCM	1.00	1.50	2.50	23					3.30	27.50		

\* Dry Film Thickness (DFT) is rounded to nearest mil, and is theoretical. Actual DFT will vary dependent on substrate profile, application technique and waste factor.

Note: DFT for 3-coursed rates includes 6 mils for the fabric.

+Eligible for 10 Year Extended Limited Warranty (color).



# Roof Mate™ + KYMAX™ QUICK SPEC

## SMOOTH & GRANULATED ASPHALTIC (KM-6)

**NOTE:** The following "Quick Spec" is an abbreviated specification and is not meant to replace the detailed specification. Complete 3-part CSI System Specifications are available at [www.gaf.com](http://www.gaf.com).



### METHOD REQUIREMENTS

#### Required:

- Moisture survey required
- Remove and replace any wet areas
- Repair membrane with like materials
- Roof must be clean, dry and tight
- No rain, dew, fog or freezing temperatures in forecast for 24 hours
- Adhesion test required
- Power washing required

#### Recommendations:

- New smooth membranes must be aged 30 days; 90 days ideal.
- Refer to Technical Data Sheet for product specific application and surface temperature restrictions.

#### Restrictions:

Do not apply over gravel-surfaced substrates.

#### Installation Overview:

1. Before coating is applied, an adhesion test is required to ensure an adhesion minimum of 2.0 pounds per linear inch (PLI). Test patches to be applied with rates listed below.
2. Power-wash substrate to remove contaminants that could negatively affect adhesion. Allow roof to completely dry.
3. Prime per chart below.
4. Treat "alligatored" areas, surface cracks, roof penetrations, drains, curbs and scuppers. (Refer to Substrate Preparation section for requirements)
5. All loose seams must be 3-coursed. All other seams must be treated with flashing grade only, no fabric required. (Refer to Seam Treatment Guide for requirements)
6. Apply coating per the chart below:

#### Surface Prep

	Product	Rate (Gal/Sq)
Cleaner	UCC Cleaner	0.5 - 0.7
Primer*	Unibase	0.5 - 1.0

\*When Roof Mate™ Base Coat or Roof Mate™ MB Plus are used, primer is not required.

#### SEAMS & DETAILS<sup>1</sup>

Treatment Type	Product	Total (Gal/Sq)	DFT* (mils)
3-Coursed Rates	Roof Mate™ Butter Grade and Fabric	4.0	43
Flashing Grade Only Rates	Roof Mate™ Butter Grade	2.0	19

Note: For other product options, please refer to our Seam Treatment Guide.

<sup>1</sup>Flashing rates are based on a 6" (152 mm) width, rates will double for 12" (305 mm) width.

### SMOOTH & GRANULATED ASPHALTIC | Roof Mate™ + KYMAX™

Coverage Term	Roof Mate™					Kymax™				Total		Warranties/ Guarantees Available+	
	Product (Choose one)	1st Coat (Gal/Sq)	2nd Coat (Gal/Sq)	Total (Gal/Sq)	DFT* (mils)	1st Coat (Gal/Sq)	2nd Coat (Gal/Sq)	Total (Gal/Sq)	DFT* (mils)	Total Gal/Sq	DFT* (mils)	Emerald Pledge™	Diamond Pledge™
15 Year+	Roof Mate™	1.50	1.50	3.00	25	0.40	0.40	0.80	4.5	3.80	29.50	Yes	No
	Roof Mate™ QS	1.50	1.50	3.00	25					3.80	29.50		
	Roof Mate™ HT	1.50	1.50	3.00	25					3.80	29.50		
	Roof Mate™ MB Plus	1.50	1.50	3.00	26					3.80	30		

\* Dry Film Thickness (DFT) is rounded to nearest mil, and is theoretical. Actual DFT will vary dependent on substrate profile, application technique and waste factor. Note: DFT for 3-coursed rates includes 6 mils for the fabric. +Eligible for 10 Year Extended Limited Warranty (color).

# Roof Mate™ + KYMAX™ QUICK SPEC

## STRUCTURAL CONCRETE & CORRUGATED STRUCTURAL TRANSITE PANELS (KM-7)

**NOTE:** The following "Quick Spec" is an abbreviated specification and is not meant to replace the detailed specification. Complete 3-part CSI System Specifications are available at [www.gaf.com](http://www.gaf.com).



### METHOD REQUIREMENTS

#### Required:

- Moisture survey required (must contain less than 8% moisture)
- Remove and replace any wet areas
- Repair membrane with like materials
- Roof must be clean, dry and tight
- No rain, dew, fog or freezing temperatures in forecast for 24 hours
- Adhesion test required
- Power washing required
- Concrete must be fully cured

#### Recommendations:

- Refer to Technical Data Sheet for product specific application and surface temperature restrictions.

#### Installation Overview:

1. Before coating is applied, an adhesion test is required to ensure an adhesion minimum of 2.0 pounds per linear inch (PLI). Test patches to be applied with rates listed below.
2. Power-wash substrate to remove contaminants that could negatively affect adhesion. Allow roof to completely dry.
3. Prime per chart below.
4. Treat all roof penetrations, drains, curbs, and scuppers. (Refer to Substrate Preparation section for requirements)
5. Treat structural joints with backer rod and compatible sealant prior to seam treatment. (Refer to Seam Treatment Guide for requirements)
6. Control joints in excess of 1/16" (1.6mm) shall also be caulked with a compatible caulk.
7. Apply coating per the chart below:

### CLEAN / PRIME

	Product	Rate (Gal/Sq)
Cleaner	UCC Cleaner	0.5 - 0.7
Primer	Epoxy Primer	0.30 - 0.40

### SEAMS & DETAILS<sup>1</sup>

Treatment Type	Product	Total (Gal/Sq)	DFT* (mils)
3-Coursed Rates	Roof Mate™ Butter Grade and Fabric	4.0	43
Flashing Grade Only Rates	Roof Mate™ Butter Grade	2.0	19

Note: For other product options, please refer to our Seam Treatment Guide.

<sup>1</sup>Flashing rates are based on a 6" (152 mm) width, rates will double for 12" (305 mm) width.

## STRUCTURAL CONCRETE & CORRUGATED STRUCTURAL TRANSITE PANELS

Coverage Term	Roof Mate™					Kymax™				Total		Warranties/ Guarantees Available+	
	Product (Choose one)	1st Coat (Gal/Sq)	2nd Coat (Gal/Sq)	Total (Gal/Sq)	DFT* (mils)	1st Coat (Gal/Sq)	2nd Coat (Gal/Sq)	Total (Gal/Sq)	DFT* (mils)	Total Gal/Sq	DFT* (mils)	Emerald Pledge™	Diamond Pledge™
15 Year+	Roof Mate™	1.5	1.5	3.0	25	0.40	0.40	0.80	4.5	3.8	29.5	Yes	No
	Roof Mate™ QS	1.5	1.5	3.0	25					3.8	29.5		
	Roof Mate™ HT	1.5	1.5	3.0	25					3.8	29.5		
	Roof Mate™ TCM	1.5	1.5	3.0	29					3.8	33.5		

\* Dry Film Thickness (DFT) is rounded to nearest mil, and is theoretical. Actual DFT will vary dependent on substrate profile, application technique and waste factor.

Note: DFT for 3-coursed rates includes 6 mils for the fabric.

+Eligible for 10 Year Extended Limited Warranty (color).

**Important Note:** Corrugated structural transite panels may contain asbestos. Follow all applicable local, state and federal regulations concerning asbestos. Under no circumstances does GAF have any liability for any damages, costs or expenses arising out of or associated with the pre-existing presence of asbestos-containing materials or any other allegedly hazardous substance or materials upon the roof to which the new GAF roofing materials are being applied.

# Roof Mate™ + KYMAX™ QUICK SPEC

## LOGO WORK (KM-8)

**NOTE:** The following “Quick Spec” is an abbreviated specification and is not meant to replace the detailed specification. Complete 3-part CSI System Specifications are available at [www.gaf.com](http://www.gaf.com).



### METHOD REQUIREMENTS

#### Required:

- Moisture survey required
- Remove and replace any wet areas
- Repair membrane with like materials
- Roof must be clean, dry and tight
- No rain, dew, fog or freezing temperatures in forecast for 24 hours
- Approved substrates: metal, smooth and granulated asphaltic, TPO, PVC, Hypalon®, EPDM, structural concrete and corrugate structural panels.
- Adhesion test required
- Power washing required

#### Recommendations:

- Refer to Technical Data Sheet for product specific application and surface temperature restrictions.

#### Installation Overview:

1. Refer to the appropriate substrate specific Roof Mate™ Quick Spec for requirements prior applying Kymax™.
2. Before applying Kymax™, an adhesion test is required to ensure an adhesion minimum of 2.0 pounds per linear inch (PLI). Test patches to be applied with rates listed below.
4. Apply coating per the chart below:

LOGO WORK								
Warranty/ Guarantee term	Roof Mate™		Kymax™				Total	
	Total (Gal/Sq)	DFT* (mils)	1st Coat (Gal/Sq)	2nd Coat (Gal/Sq)	Total (Gal/Sq)	DFT* (mils)	Total Gal/Sq	DFT* (mils)
<b>10 Year Extended Limited</b>	1.50	13	0.40	0.40	0.80	4.5	2.30	17.50

Dry Film Thickness (DFT) is rounded to nearest mil, and is theoretical. Actual DFT will vary dependent on substrate profile, application technique and waste factor.

Note: DFT for 3-coursed rates includes 6 mils for the fabric.

# KYMAX™ QUICK SPEC

## METAL RESTORATION (KM-9)

**NOTE:** The following “Quick Spec” is an abbreviated specification and is not meant to replace the detailed specification. Complete 3-part CSI System Specifications are available at [www.gaf.com](http://www.gaf.com).



### METHOD REQUIREMENTS

#### Required:

- Roof must be clean, dry and tight
- No rain, dew, fog or freezing temperatures in forecast for 24 hours
- Adhesion test required
- Power washing required

#### Recommendations:

- Refer to Technical Data Sheet for product specific application and surface temperature restrictions.

#### Installation Overview:

1. Before coating is applied, an adhesion test is required to ensure an adhesion minimum of 2.0 pounds per linear inch (PLI). Test patches to be applied with rates listed below.

2. Tighten/replace existing fasteners. Encapsulate with appropriate flashing material.
3. Power-wash substrate to remove contaminants that could negatively affect adhesion. Allow roof to completely dry.
4. Install crickets to divert water and complete other necessary sheet metal repairs.
5. Prime rusty areas per chart below.
6. Treat all roof penetrations, drains, curbs, and scuppers. (Refer to Substrate Preparation section for requirements)
7. Horizontal seams must be 3-coursed. Overlap and trapezoidal vertical seams must be treated with flashing grade only. Other vertical seams may forgo treatment **IF** the seal/tape is intact on the seam or if they are double locked. (Refer to Seam Treatment Guide for requirements)
8. Apply coating per the chart below:

CLEAN / PRIME		
	Product	Rate (Gal/Sq)
Cleaner	UCC Cleaner (diluted)	0.5 - 0.7
Primer (rusty areas)	Acrylex 400	0.3 - 0.5
Primer (severe rust)	Lock-Down Primer	0.25 - 0.33

SEAMS & DETAILS <sup>1</sup>				
Treatment Type	Product	Total (Gal/Sq)	DFT* (mils)	
3-Coursed Rates	Roof Mate™ Butter Grade & Fabric	4.0	43	
Flashing Grade Only Rates	Roof Mate™ Butter Grade	2.0	19	

*Note: For other product options, please refer to our Seam Treatment Guide.  
<sup>1</sup>Flashing rates are based on a 6" (152 mm) width, rates will double for 12" (305 mm) width.*

METAL RESTORATION KYMAX™					
Warranty/ Guarantee term	Acrylex 400	Kymax™			
	Total (Gal/Sq)	1st Coat (Gal/Sq)	2nd Coat (Gal/Sq)	Total (Gal/Sq)	DFT* (mils)
10 Year Extended Limited Color	0.50	0.40	0.40	0.80	4.5

\* Dry Film Thickness (DFT) is rounded to nearest mil, and is theoretical. Actual DFT will vary dependent on substrate profile, application technique and waste factor.

## ROOFSHIELD® I.S. QUICK SPEC DIRECTORY

Spec Number	Substrate Specification	Page #
RS-1 (RST Sprayer)	Roofshield® I.S. over TPO	85
RS-1 (CJ Sprayer)	Roofshield® I.S. over TPO	86
RS-2 (RST Sprayer)	Roofshield® I.S. over PVC	87
RS-2 (CJ Sprayer)	Roofshield® I.S. over PVC	88
RS-3 (RST Sprayer)	Roofshield® I.S. over Hypalon®	89
RS-3 (CJ Sprayer)	Roofshield® I.S. over Hypalon®	90
RS-4 (RST Sprayer)	Roofshield® I.S. over EPDM	91
RS-4 (CJ Sprayer)	Roofshield® I.S. over EPDM	92
RS-5 (RST Sprayer)	Roofshield® I.S. over Granulated Asphaltic	93
RS-5 (CJ Sprayer)	Roofshield® I.S. over Granulated Asphaltic	94
RS-6 (RST Sprayer)	Roofshield® I.S. over Structural Concrete	95
RS-6 (CJ Sprayer)	Roofshield® I.S. over Structural Concrete	86
RS-7 (RST Sprayer)	Roofshield® I.S. over Corrugated Structural Transite Panel	97
RS-7 (CJ Sprayer)	Roofshield® I.S. over Corrugated Structural Transite Panel	98
RS-8 (RST Sprayer)	Roofshield® I.S. over Metal	99
RS-8 (CJ Sprayer)	Roofshield® I.S. over Metal	100

*Quick Specs are abbreviated specifications and are not meant to replace detailed specifications. Complete 3-part CSI System Specifications are available at [www.gaf.com](http://www.gaf.com).*

# ROOFSHIELD® I.S. QUICK SPEC

## TPO (RS-1)

**RST  
SPRAYER**

**NOTE:** The following "Quick Spec" is an abbreviated specification and is not meant to replace the detailed specification. Complete 3-part CSI System Specifications are available at [www.gaf.com](http://www.gaf.com).

### METHOD REQUIREMENTS

#### Required:

- Moisture survey required
- Remove and replace any wet areas
- Repair membrane with like materials
- Roof must be clean, dry, and tight
- Adhesion test required
- Power washing required
- No rain, dew, fog or freezing temperatures in forecast for 24 hours
- Refer to Technical Data Sheet for product specific application and surface temperature restrictions

#### Installation Overview:

1. Before coating is applied, an adhesion test is required to ensure an adhesion minimum of 2.0 pounds per linear inch (PLI). Test patches will be conducted with Part A only (uncatalyzed) and should be applied with enough material to embed the fabric.

2. Power-wash substrate to remove contaminants that could negatively affect adhesion. Allow roof to completely dry.
3. Prime per chart below.
4. Treat all roof penetrations, drains, curbs, and scuppers. (Refer to Substrate Preparation section for requirements)
5. All loose seams must be 3-coursed. All other seams must be treated with flashing grade only, no fabric required. (Refer to Seam Treatment Guide for requirements)
6. This is a two-part product that will be applied via a specialized RST sprayer, where the product will be catalyzed as it is sprayed.
7. Apply the catalyzed coating per the chart below:

#### CLEAN / PRIME

	Product	Rate (Gal/Sq)
Cleaner	UCC Cleaner	0.5 - 0.7
Primer	Unisil Primer	0.33

#### SEAMS & DETAILS<sup>1</sup>

Treatment Type	Product	Total (Gal/Sq)	DFT* (mils)
3-Coursed Rates	Roof Mate™ Butter Grade and Fabric	4.0	43
Flashing Grade Only Rates	Roof Mate™ Butter Grade	2.0	19

\* Dry Film Thickness (DFT) is rounded to nearest mil, and is theoretical. Actual DFT will vary dependent on substrate profile, application technique and waste factor.  
 Note: DFT for 3-coursed rates includes 6 mils for the fabric.  
 Note: For other product options, please refer to our Seam Treatment Guide.  
<sup>1</sup>Flashing rates are based on a 6" (152 mm) width, rates will double for 12" (305 mm) width.

#### RST Sprayer Catalyst Pressure Settings<sup>∅</sup> (PSI) for Different Temperature-Humidity Conditions

Choose the temperature and humidity closest to current conditions to find an initial catalyst pressure setting <sup>∅</sup> .	Temperature, °F			
	Hot (80°F-100°F)	Moderate (65°F-80°F)	Cold (50°F-65°F)	
Humidity, %	Humid (50%-80%)	50	60	70
	Moderate (30%-50%)	45	50	60
	Dry (15%-30%)	40	45	50

<sup>∅</sup> Catalyst pressure needs to be optimized based on actual ambient condition, wind speed, and elevation. For best results, conduct a spray test in current conditions to confirm appropriate catalyst settings. This chart is only intended to serve as an estimated initial starting point.

#### TPO ROOFSHIELD® I.S.

Coverage Term	Coating		Warranty/Guarantee**	
	1st Coat (Gal/Sq)	DFT* (mils)	Emerald Pledge™	Diamond Pledge™
10 Year	3.0	25	Yes**	No

\*\* Contractors must receive specialized training on the RST Spray equipment for enhanced system warranties or guarantees. Contact Technical Support Services for more information.

# ROOFSHIELD® I.S. QUICK SPEC

## TPO (RS-1)

CJ  
SPRAYER

**NOTE:** The following "Quick Spec" is an abbreviated specification and is not meant to replace the detailed specification. Complete 3-part CSI System Specifications are available at [www.gaf.com](http://www.gaf.com).

### METHOD REQUIREMENTS

#### Required:

- Moisture survey required
- Remove and replace any wet areas
- Repair membrane with like materials
- Roof must be clean, dry, and tight
- Adhesion test required
- Power washing required
- No rain, dew, fog or freezing temperatures in forecast for 24 hours
- Refer to Technical Data Sheet for product specific application and surface temperature restrictions

#### Installation Overview:

1. Before coating is applied, an adhesion test is required to ensure an adhesion minimum of 2.0 pounds per linear inch (PLI). Test patches will be conducted with Part A only (uncatalyzed) and will be applied with enough material to embed the fabric.

2. Power-wash substrate to remove contaminants that could negatively affect adhesion. Allow roof to completely dry.
3. Prime per chart below.
4. Treat all roof penetrations, drains, curbs, and scuppers. (Refer to Substrate Preparation section for requirements)
5. All loose seams must be 3-coursed. All other seams must be treated with flashing grade only, no fabric required. (Refer to Seam Treatment Guide for requirements)
6. This is a two-part product that will be applied via a specialized CJ sprayer, where the product will be catalyzed as it is sprayed.
7. Apply the catalyzed coating per the chart below:

#### CLEAN / PRIME

	Product	Rate (Gal/Sq)
Cleaner	UCC Cleaner	0.5 - 0.7
Primer	Unisil Primer	0.33

#### SEAMS & DETAILS<sup>1</sup>

Treatment Type	Product	Total (Gal/Sq)	DFT* (mils)
3-Coursed Rates	Roof Mate™ Butter Grade and Fabric	4.0	43
Flashing Grade Only Rates	Roof Mate™ Butter Grade	2.0	19

\* Dry Film Thickness (DFT) is rounded to nearest mil, and is theoretical. Actual DFT will vary dependent on substrate profile, application technique and waste factor.  
 Note: DFT for 3-coursed rates includes 6 mils for the fabric.  
 Note: For other product options, please refer to our Seam Treatment Guide.  
<sup>1</sup>Flashing rates are based on a 6" (152 mm) width, rates will double for 12" (305 mm) width.

#### Tip Combination for CJ's Sprayer (Coating pressure range: 850 - 1000 psi & Catalyst pressure @ 100 psi)

Choose the temperature and humidity closest to current conditions to find an initial tip combinations.	Temperature, °F			
	Hot (80°F-100°F) (26°C-37°C)	Moderate (65°F-80°F) (18°C-26°C)	Cold (50°F-65°F) (10°C-18°C)	
Humidity, %	Humid (50%-80%)	561/9502 (557/9502)	561/9502 (557/9502)	561/9502 (557/9502)
	Moderate (30%-50%)	565/9502 (561/9502)	561/9502 (557/9502)	561/9502 (557/9502)
	Dry (15%-30%)	565/9502 (561/9502)	561/9502 (557/9502)	561/9502 (557/9502)

#### Note: (Coating Tip/Catalyst Tip)

Tip combination and coating pressure need to be optimized based on actual ambient condition, wind speed, elevation, and length of the spray hose. For best results, conduct a spray test in current conditions to confirm appropriate tip combinations and coating pressure settings. This chart is only intended to serve as an estimated initial starting point.

#### TPO ROOFSHIELD® I.S.

Coverage Term	Coating		Warranty/Guarantee**	
	1st Coat (Gal/Sq)	DFT* (mils)	Emerald Pledge™	Diamond Pledge™
10 Year	3.0	25	Yes**	No

\*\* Contractors must receive specialized training on the CJ Spray equipment for enhanced system warranties or guarantees. Contact Technical Support Services for more information.

# ROOFSHIELD® I.S. QUICK SPEC

## PVC (RS-2)

**RST  
SPRAYER**

**NOTE:** The following “Quick Spec” is an abbreviated specification and is not meant to replace the detailed specification. Complete 3-part CSI System Specifications are available at [www.gaf.com](http://www.gaf.com).

### METHOD REQUIREMENTS

#### Required:

- Moisture survey required
- Remove and replace any wet areas
- Repair membrane with like materials
- Roof must be clean, dry, and tight
- Adhesion test required
- Power washing required
- No rain, dew, fog or freezing temperatures in forecast for 24 hours
- Refer to Technical Data Sheet for product specific application and surface temperature restrictions.

#### Installation Overview:

1. Before coating is applied, an adhesion test is required to ensure an adhesion minimum of 2.0 pounds per linear inch (PLI). Test patches will be conducted with Part A only (uncatalyzed) and should be applied with enough material to embed the fabric.

2. Power-wash substrate to remove contaminants that could negatively affect adhesion. Allow roof to completely dry.
3. Prime per chart below.
4. Treat all roof penetrations, drains, curbs, and scuppers. (Refer to Substrate Preparation section for requirements)
5. All loose seams must be 3-coursed. All other seams must be treated with flashing grade only, no fabric required. (Refer to Seam Treatment Guide for requirements)
6. This is a two-part product that will be applied via a specialized RST sprayer, where the product will be catalyzed as it is sprayed.
7. Apply the catalyzed coating per the chart below:

#### CLEAN / PRIME

	Product	Rate (Gal/Sq)
Cleaner	UCC Cleaner	0.5 - 0.7
Primer	Unisil Primer	0.33

#### SEAMS & DETAILS<sup>1</sup>

Treatment Type	Product	Total (Gal/Sq)	DFT* (mils)
3-Coursed Rates	Roof Mate™ Butter Grade and Fabric	4.0	43
Flashing Grade Only Rates	Roof Mate™ Butter Grade	2.0	19

\* Dry Film Thickness (DFT) is rounded to nearest mil, and is theoretical. Actual DFT will vary dependent on substrate profile, application technique and waste factor.  
 Note: DFT for 3-coursed rates includes 6 mils for the fabric.  
 Note: For other product options, please refer to our Seam Treatment Guide.  
<sup>1</sup>Flashing rates are based on a 6" (152 mm) width, rates will double for 12" (305 mm) width.

#### RST Sprayer Catalyst Pressure Settings<sup>‡</sup> (PSI) for Different Temperature-Humidity Conditions

Choose the temperature and humidity closest to current conditions to find an initial catalyst pressure setting <sup>‡</sup> .	Temperature, °F			
	Hot (80°F-100°F)	Moderate (65°F-80°F)	Cold (50°F-65°F)	
Humidity, %	Humid (50%-80%)	50	60	70
	Moderate (30%-50%)	45	50	60
	Dry (15%-30%)	40	45	50

<sup>‡</sup> Catalyst pressure needs to be optimized based on actual ambient condition, wind speed, and elevation. For best results, conduct a spray test in current conditions to confirm appropriate catalyst settings. This chart is only intended to serve as an estimated initial starting point.

#### PVC ROOFSHIELD® I.S.

Coverage Term	Coating		Warranty/Guarantee**	
	1st Coat (Gal/Sq)	DFT* (mils)	Emerald Pledge™	Diamond Pledge™
10 Year	3.0	25	Yes**	No

\*\* Contractors must receive specialized training on the RST Spray equipment for enhanced system warranties or guarantees. Contact Technical Support Services for more information.



# ROOFSHIELD® I.S. QUICK SPEC

## PVC (RS-2)

CJ  
SPRAYER

**NOTE:** The following "Quick Spec" is an abbreviated specification and is not meant to replace the detailed specification. Complete 3-part CSI System Specifications are available at [www.gaf.com](http://www.gaf.com).

### METHOD REQUIREMENTS

#### Required:

- Moisture survey required
- Remove and replace any wet areas
- Repair membrane with like materials
- Roof must be clean, dry, and tight
- Adhesion test required
- Power washing required
- No rain, dew, fog or freezing temperatures in forecast for 24 hours
- Refer to Technical Data Sheet for product specific application and surface temperature restrictions.

#### Installation Overview:

1. Before coating is applied, an adhesion test is required to ensure an adhesion minimum of 2.0 pounds per linear inch (PLI). Test patches will be conducted with Part A only (uncatalyzed) and will be applied with enough material to embed the fabric.

2. Power-wash substrate to remove contaminants that could negatively affect adhesion. Allow roof to completely dry.
3. Prime per chart below.
4. Treat all roof penetrations, drains, curbs, and scuppers. (Refer to Substrate Preparation section for requirements)
5. All loose seams must be 3-coursed. All other seams must be treated with flashing grade only, no fabric required. (Refer to Seam Treatment Guide for requirements)
6. This is a two-part product that will be applied via a specialized CJ sprayer, where the product will be catalyzed as it is sprayed.
7. Apply the catalyzed coating per the chart below:

#### CLEAN / PRIME

	Product	Rate (Gal/Sq)
Cleaner	UCC Cleaner	0.5 - 0.7
Primer	Unisil Primer	0.33

#### SEAMS & DETAILS<sup>1</sup>

Treatment Type	Product	Total (Gal/Sq)	DFT* (mils)
3-Coursed Rates	Roof Mate™ Butter Grade and Fabric	4.0	43
Flashing Grade Only Rates	Roof Mate™ Butter Grade	2.0	19

\* Dry Film Thickness (DFT) is rounded to nearest mil, and is theoretical. Actual DFT will vary dependent on substrate profile, application technique and waste factor.  
 Note: DFT for 3-coursed rates includes 6 mils for the fabric.  
 Note: For other product options, please refer to our Seam Treatment Guide.  
<sup>1</sup>Flashing rates are based on a 6" (152 mm) width, rates will double for 12" (305 mm) width.

#### Tip Combination for CJ's Sprayer (Coating pressure range: 850 - 1000 psi & Catalyst pressure @ 100 psi)

Choose the temperature and humidity closest to current conditions to find an initial tip combinations.	Temperature, °F			
	Hot (80°F-100°F) (26°C-37°C)	Moderate (65°F-80°F) (18°C-26°C)	Cold (50°F-65°F) (10°C-18°C)	
Humidity, %	Humid (50%-80%)	561/9502 (557/9502)	561/9502 (557/9502)	561/9502 (557/9502)
	Moderate (30%-50%)	565/9502 (561/9502)	561/9502 (557/9502)	561/9502 (557/9502)
	Dry (15%-30%)	565/9502 (561/9502)	561/9502 (557/9502)	561/9502 (557/9502)

**Note: (Coating Tip/Catalyst Tip)**

Tip combination and coating pressure need to be optimized based on actual ambient condition, wind speed, elevation, and length of the spray hose. For best results, conduct a spray test in current conditions to confirm appropriate tip combinations and coating pressure settings. This chart is only intended to serve as an estimated initial starting point.

### PVC ROOFSHIELD® I.S.

Coverage Term	Coating		Warranty/Guarantee**	
	1st Coat (Gal/Sq)	DFT* (mils)	Emerald Pledge™	Diamond Pledge™
10 Year	3.0	25	Yes**	No

\*\* Contractors must receive specialized training on the CJ Spray equipment for enhanced system warranties or guarantees. Contact Technical Support Services for more information.

# ROOFSHIELD® I.S. QUICK SPEC

## Hypalon® (RS-3)

**RST  
SPRAYER**

**NOTE:** The following "Quick Spec" is an abbreviated specification and is not meant to replace the detailed specification. Complete 3-part CSI System Specifications are available at [www.gaf.com](http://www.gaf.com).

### METHOD REQUIREMENTS

#### Required:

- Moisture survey required
- Remove and replace any wet areas
- Repair membrane with like materials
- Roof must be clean, dry, and tight
- Adhesion test required
- Power washing required
- No rain, dew, fog or freezing temperatures in forecast for 24 hours
- Refer to Technical Data Sheet for product specific application and surface temperature restrictions.

#### Installation Overview:

1. Before coating is applied, an adhesion test is required to ensure an adhesion minimum of 2.0 pounds per linear inch (PLI). Test patches will be conducted with Part A only (uncatalyzed) and should be applied with enough material to embed the fabric.

2. Power-wash substrate to remove contaminants that could negatively affect adhesion. Allow roof to completely dry.
3. Prime per chart below.
4. Treat all roof penetrations, drains, curbs, and scuppers. (Refer to Substrate Preparation section for requirements)
5. All loose seams must be 3-coursed. All other seams must be treated with flashing grade only, no fabric required. (Refer to Seam Treatment Guide for requirements)
6. This is a two-part product that will be applied via a specialized RST sprayer, where the product will be catalyzed as it is sprayed.
7. Apply the catalyzed coating per the chart below:

#### CLEAN / PRIME

	Product	Rate (Gal/Sq)
Cleaner	UCC Cleaner	0.5 - 0.7
Primer	Unisil Primer	0.33

#### SEAMS & DETAILS<sup>1</sup>

Treatment Type	Product	Total (Gal/Sq)	DFT* (mils)
3-Coursed Rates	Roof Mate™ Butter Grade and Fabric	4.0	43
Flashing Grade Only Rates	Roof Mate™ Butter Grade	2.0	19

\* Dry Film Thickness (DFT) is rounded to nearest mil, and is theoretical. Actual DFT will vary dependent on substrate profile, application technique and waste factor.  
 Note: DFT for 3-coursed rates includes 6 mils for the fabric.  
 Note: For other product options, please refer to our Seam Treatment Guide.  
<sup>1</sup>Flashing rates are based on a 6" (152 mm) width, rates will double for 12" (305 mm) width.

#### RST Sprayer Catalyst Pressure Settings<sup>◇</sup> (PSI) for Different Temperature-Humidity Conditions

Choose the temperature and humidity closest to current conditions to find an initial catalyst pressure setting <sup>◇</sup> .	Temperature, °F			
	Hot (80°F-100°F)	Moderate (65°F-80°F)	Cold (50°F-65°F)	
Humidity, %	Humid (50%-80%)	50	60	70
	Moderate (30%-50%)	45	50	60
	Dry (15%-30%)	40	45	50

<sup>◇</sup> Catalyst pressure needs to be optimized based on actual ambient condition, wind speed, and elevation. For best results, conduct a spray test in current conditions to confirm appropriate catalyst settings. This chart is only intended to serve as an estimated initial starting point.

### Hypalon® ROOFSHIELD® I.S.

Coverage Term	Coating		Warranty/Guarantee**	
	1st Coat (Gal/Sq)	DFT* (mils)	Emerald Pledge™	Diamond Pledge™
10 Year	3.0	25	Yes**	No

\*\* Contractors must receive specialized training on the RST Spray equipment for enhanced system warranties or guarantees. Contact Technical Support Services for more information.

# ROOFSHIELD® I.S. QUICK SPEC

## Hypalon® (RS-3)

**CJ  
SPRAYER**

**NOTE:** The following "Quick Spec" is an abbreviated specification and is not meant to replace the detailed specification. Complete 3-part CSI System Specifications are available at [www.gaf.com](http://www.gaf.com).

### METHOD REQUIREMENTS

#### Required:

- Moisture survey required
- Remove and replace any wet areas
- Repair membrane with like materials
- Roof must be clean, dry, and tight
- Adhesion test required
- Power washing required
- No rain, dew, fog or freezing temperatures in forecast for 24 hours
- Refer to Technical Data Sheet for product specific application and surface temperature restrictions.

#### Installation Overview:

1. Before coating is applied, an adhesion test is required to ensure an adhesion minimum of 2.0 pounds per linear inch (PLI). Test patches will be conducted with Part A only (uncatalyzed) and will be applied with enough material to embed the fabric.

2. Power-wash substrate to remove contaminants that could negatively affect adhesion. Allow roof to completely dry.
3. Prime per chart below.
4. Treat all roof penetrations, drains, curbs, and scuppers. (Refer to Substrate Preparation section for requirements)
5. All loose seams must be 3-coursed. All other seams must be treated with flashing grade only, no fabric required. (Refer to Seam Treatment Guide for requirements)
6. This is a two-part product that will be applied via a specialized CJ sprayer, where the product will be catalyzed as it is sprayed.
7. Apply the catalyzed coating per the chart below:

CLEAN / PRIME		
	Product	Rate (Gal/Sq)
Cleaner	UCC Cleaner	0.5 - 0.7
Primer	Unisil Primer	0.33

#### Tip Combination for CJ's Sprayer (Coating pressure range: 850 - 1000 psi & Catalyst pressure @ 100 psi)

Choose the temperature and humidity closest to current conditions to find an initial tip combinations.	Temperature, °F			
	Hot (80°F-100°F) (26°C-37°C)	Moderate (65°F-80°F) (18°C-26°C)	Cold (50°F-65°F) (10°C-18°C)	
Humidity, %	Humid (50%-80%)	561/9502 (557/9502)	561/9502 (557/9502)	561/9502 (557/9502)
	Moderate (30%-50%)	565/9502 (561/9502)	561/9502 (557/9502)	561/9502 (557/9502)
	Dry (15%-30%)	565/9502 (561/9502)	561/9502 (557/9502)	561/9502 (557/9502)

**Note: (Coating Tip/Catalyst Tip)**

Tip combination and coating pressure need to be optimized based on actual ambient condition, wind speed, elevation, and length of the spray hose. For best results, conduct a spray test in current conditions to confirm appropriate tip combinations and coating pressure settings. This chart is only intended to serve as an estimated initial starting point.

SEAMS & DETAILS <sup>1</sup>			
Treatment Type	Product	Total (Gal/Sq)	DFT* (mils)
3-Coursed Rates	Roof Mate™ Butter Grade and Fabric	4.0	43
Flashing Grade Only Rates	Roof Mate™ Butter Grade	2.0	19

\* Dry Film Thickness (DFT) is rounded to nearest mil, and is theoretical. Actual DFT will vary dependent on substrate profile, application technique and waste factor.  
 Note: DFT for 3-coursed rates includes 6 mils for the fabric.  
 Note: For other product options, please refer to our Seam Treatment Guide.  
<sup>1</sup>Flashing rates are based on a 6" (152 mm) width, rates will double for 12" (305 mm) width.

Hypalon® ROOFSHIELD® I.S.				
Coverage Term	Coating		Warranty/Guarantee**	
	1st Coat (Gal/Sq)	DFT* (mils)	Emerald Pledge™	Diamond Pledge™
10 Year	3.0	25	Yes**	No

\*\* Contractors must receive specialized training on the CJ Spray equipment for enhanced system warranties or guarantees. Contact Technical Support Services for more information.

# ROOFSHIELD® I.S. QUICK SPEC

## EPDM (RS-4)

**RST  
SPRAYER**

**NOTE:** The following "Quick Spec" is an abbreviated specification and is not meant to replace the detailed specification. Complete 3-part CSI System Specifications are available at [www.gaf.com](http://www.gaf.com).

### METHOD REQUIREMENTS

#### Required:

- Moisture survey required
- Remove and replace any wet areas
- Repair membrane with like materials
- Roof must be clean, dry, and tight
- Adhesion test required
- Power washing required
- No rain, dew, fog or freezing temperatures in forecast for 24 hours
- Refer to Technical Data Sheet for product specific application and surface temperature restrictions.

#### Installation Overview:

1. Before coating is applied, an adhesion test is required to ensure an adhesion minimum of 2.0 pounds per linear inch (PLI). Test patches will be conducted with Part A only (uncatalyzed) and should be applied with enough material to embed the fabric.

2. Power-wash substrate to remove contaminants that could negatively affect adhesion. Allow roof to completely dry.
3. Prime per chart below.
4. Treat all roof penetrations, drains, curbs, and scuppers. (Refer to Substrate Preparation section for requirements)
5. All loose seams must be 3-coursed. All other seams must be treated with flashing grade only, no fabric required. (Refer to Seam Treatment Guide for requirements)
6. This is a two-part product that will be applied via a specialized RST sprayer, where the product will be catalyzed as it is sprayed.
7. Apply the catalyzed coating per the chart below:

#### CLEAN / PRIME

	Product	Rate (Gal/Sq)
Cleaner	UCC Cleaner	0.5 - 0.7
Primer	Clean Act Primer	0.20
	TPO Red Prime	0.33

#### SEAMS & DETAILS<sup>1</sup>

Treatment Type	Product	Total (Gal/Sq)	DFT* (mils)
3-Coursed Rates	Roof Mate™ Butter Grade and Fabric	4.0	43
Flashing Grade Only Rates	Roof Mate™ Butter Grade	2.0	19

\* Dry Film Thickness (DFT) is rounded to nearest mil, and is theoretical. Actual DFT will vary dependent on substrate profile, application technique and waste factor.  
 Note: DFT for 3-coursed rates includes 6 mils for the fabric.  
 Note: For other product options, please refer to our Seam Treatment Guide.  
<sup>1</sup>Flashing rates are based on a 6" (152 mm) width, rates will double for 12" (305 mm) width.

#### RST Sprayer Catalyst Pressure Settings<sup>◇</sup> (PSI) for Different Temperature-Humidity Conditions

Choose the temperature and humidity closest to current conditions to find an initial catalyst pressure setting <sup>◇</sup> .	Temperature, °F			
	Hot (80°F-100°F)	Moderate (65°F-80°F)	Cold (50°F-65°F)	
Humidity, %	Humid (50%-80%)	50	60	70
	Moderate (30%-50%)	45	50	60
	Dry (15%-30%)	40	45	50

<sup>◇</sup> Catalyst pressure needs to be optimized based on actual ambient condition, wind speed, and elevation. For best results, conduct a spray test in current conditions to confirm appropriate catalyst settings. This chart is only intended to serve as an estimated initial starting point.

#### EPDM ROOFSHIELD® I.S.

Coverage Term	Coating		Warranty/Guarantee**	
	1st Coat (Gal/Sq)	DFT* (mils)	Emerald Pledge™	Diamond Pledge™
10 Year	3.0	25	Yes**	No

\*\* Contractors must receive specialized training on the RST Spray equipment for enhanced system warranties or guarantees. Contact Technical Support Services for more information.

# ROOFSHIELD® I.S. QUICK SPEC

## EPDM (RS-4)

**CJ  
SPRAYER**

**NOTE:** The following "Quick Spec" is an abbreviated specification and is not meant to replace the detailed specification. Complete 3-part CSI System Specifications are available at [www.gaf.com](http://www.gaf.com).

### METHOD REQUIREMENTS

#### Required:

- Moisture survey required
- Remove and replace any wet areas
- Repair membrane with like materials
- Roof must be clean, dry, and tight
- Adhesion test required
- Power washing required
- No rain, dew, fog or freezing temperatures in forecast for 24 hours
- Refer to Technical Data Sheet for product specific application and surface temperature restrictions.

#### Installation Overview:

1. Before coating is applied, an adhesion test is required to ensure an adhesion minimum of 2.0 pounds per linear inch (PLI). Test patches will be conducted with Part A only (uncatalyzed) and will be applied with enough material to embed the fabric.

2. Power-wash substrate to remove contaminants that could negatively affect adhesion. Allow roof to completely dry.
3. Prime per chart below.
4. Treat all roof penetrations, drains, curbs, and scuppers. (Refer to Substrate Preparation section for requirements)
5. All loose seams must be 3-coursed. All other seams must be treated with flashing grade only, no fabric required. (Refer to Seam Treatment Guide for requirements)
6. This is a two-part product that will be applied via a specialized CJ sprayer, where the product will be catalyzed as it is sprayed.
7. Apply the catalyzed coating per the chart below:

#### CLEAN / PRIME

	Product	Rate (Gal/Sq)
Cleaner	UCC Cleaner	0.5 - 0.7
Primer	Clean Act Primer	0.20
	TPO Red Prime	0.33

#### SEAMS & DETAILS<sup>1</sup>

Treatment Type	Product	Total (Gal/Sq)	DFT* (mils)
3-Coursed Rates	Roof Mate™ Butter Grade and Fabric	4.0	43
Flashing Grade Only Rates	Roof Mate™ Butter Grade	2.0	19

\* Dry Film Thickness (DFT) is rounded to nearest mil, and is theoretical. Actual DFT will vary dependent on substrate profile, application technique and waste factor.  
 Note: DFT for 3-coursed rates includes 6 mils for the fabric.  
 Note: For other product options, please refer to our Seam Treatment Guide.  
<sup>1</sup>Flashing rates are based on a 6" (152 mm) width, rates will double for 12" (305 mm) width.

#### Tip Combination for CJ's Sprayer (Coating pressure range: 850 - 1000 psi & Catalyst pressure @ 100 psi)

Choose the temperature and humidity closest to current conditions to find an initial tip combinations.	Temperature, °F			
	Hot (80°F-100°F) (26°C-37°C)	Moderate (65°F-80°F) (18°C-26°C)	Cold (50°F-65°F) (10°C-18°C)	
Humidity, %	Humid (50%-80%)	561/9502 (557/9502)	561/9502 (557/9502)	561/9502 (557/9502)
	Moderate (30%-50%)	565/9502 (561/9502)	561/9502 (557/9502)	561/9502 (557/9502)
	Dry (15%-30%)	565/9502 (561/9502)	561/9502 (557/9502)	561/9502 (557/9502)

**Note: (Coating Tip/Catalyst Tip)**

Tip combination and coating pressure need to be optimized based on actual ambient condition, wind speed, elevation, and length of the spray hose. For best results, conduct a spray test in current conditions to confirm appropriate tip combinations and coating pressure settings. This chart is only intended to serve as an estimated initial starting point.

### EPDM ROOFSHIELD® I.S.

Coverage Term	Coating		Warranty/Guarantee**	
	1st Coat (Gal/Sq)	DFT* (mils)	Emerald Pledge™	Diamond Pledge™
10 Year	3.0	25	Yes**	No

\*\* Contractors must receive specialized training on the CJ Spray equipment for enhanced system warranties or guarantees. Contact Technical Support Services for more information.

# ROOFSHIELD® I.S. QUICK SPEC

## GRANULATED ASPHALTIC (RS-5)

**RST  
SPRAYER**

**NOTE:** The following "Quick Spec" is an abbreviated specification and is not meant to replace the detailed specification. Complete 3-part CSI System Specifications are available at [www.gaf.com](http://www.gaf.com).



### METHOD REQUIREMENTS

#### Required:

- Moisture survey required
- Remove and replace any wet areas
- Repair membrane with like materials
- Roof must be clean, dry, and tight
- Adhesion test required
- Power washing required
- No rain, dew, fog or freezing temperatures in forecast for 24 hours
- Refer to Technical Data Sheet for product specific application and surface temperature restrictions.
- GAF recommends that new asphaltic membranes and repairs age at least 30 days; 90+ days is ideal

#### Restrictions:

Do not apply over gravel surfaced substrates.

#### Installation Overview:

1. Before coating is applied, an adhesion test is required to ensure an adhesion minimum of 2.0 pounds per linear inch (PLI). Test patches will be conducted with Part A only (uncatalyzed) and should be applied with enough material to embed the fabric.
2. Power-wash substrate to remove contaminants that could negatively affect adhesion. Allow roof to completely dry.
3. Prime per chart below.
4. Treat "alligatored" areas, surface cracks, roof penetrations, drains, curbs and scuppers. (Refer to Substrate Preparation section for requirements)
5. All loose seams must be 3-coursed. All other seams must be treated with flashing grade only, no fabric required. (Refer to Seam Treatment Guide for requirements)
6. This is a two-part product that will be applied via a specialized RST sprayer, where the product will be catalyzed as it is sprayed.
7. Apply the catalyzed coating per the chart below:

#### CLEAN / PRIME

	Product	Rate (Gal/Sq)
Cleaner	UCC Cleaner	0.5 - 0.7
Primer	Roof Mate™ MB Plus	1.0

#### SEAMS & DETAILS<sup>1</sup>

Treatment Type	Product	Total (Gal/Sq)	DFT* (mils)
3-Coursed Rates	Roof Mate™ Butter Grade and Fabric	4.0	43
Flashing Grade Only Rates	Roof Mate™ Butter Grade	2.0	19

\* Dry Film Thickness (DFT) is rounded to nearest mil, and is theoretical. Actual DFT will vary dependent on substrate profile, application technique and waste factor.  
 Note: DFT for 3-coursed rates includes 6 mils for the fabric.  
 Note: For other product options, please refer to our Seam Treatment Guide.  
<sup>1</sup>Flashing rates are based on a 6" (152 mm) width, rates will double for 12" (305 mm) width.

#### RST Sprayer Catalyst Pressure Settings<sup>∇</sup> (PSI) for Different Temperature-Humidity Conditions

Choose the temperature and humidity closest to current conditions to find an initial catalyst pressure setting <sup>∇</sup> .	Temperature, °F			
	Hot (80°F-100°F)	Moderate (65°F-80°F)	Cold (50°F-65°F)	
Humidity, %	Humid (50%-80%)	50	60	70
	Moderate (30%-50%)	45	50	60
	Dry (15%-30%)	40	45	50

<sup>∇</sup> Catalyst pressure needs to be optimized based on actual ambient condition, wind speed, and elevation. For best results, conduct a spray test in current conditions to confirm appropriate catalyst settings. This chart is only intended to serve as an estimated initial starting point.

### GRANULATED ASPHALTIC ROOFSHIELD® I.S.

Coverage Term	Coating		Warranty/Guarantee**	
	1st Coat (Gal/Sq)	DFT* (mils)	Emerald Pledge™	Diamond Pledge™
10 Year	3.0	25	Yes**	No

\*\* Contractors must receive specialized training on the RST Spray equipment for enhanced system warranties or guarantees. Contact Technical Support Services for more information.

# ROOFSHIELD® I.S. QUICK SPEC

## GRANULATED ASPHALTIC (RS-5)

**CJ  
SPRAYER**

**NOTE:** The following "Quick Spec" is an abbreviated specification and is not meant to replace the detailed specification. Complete 3-part CSI System Specifications are available at [www.gaf.com](http://www.gaf.com).

### METHOD REQUIREMENTS

#### Required:

- Moisture survey required
- Remove and replace any wet areas
- Repair membrane with like materials
- Roof must be clean, dry, and tight
- Adhesion test required
- Power washing required
- No rain, dew, fog or freezing temperatures in forecast for 24 hours
- Refer to Technical Data Sheet for product specific application and surface temperature restrictions.
- GAF recommends that new asphaltic membranes and repairs age at least 30 days; 90+ days is ideal

#### Restrictions:

Do not apply over gravel surfaced substrates.

#### Installation Overview:

1. Before coating is applied, an adhesion test is required to ensure an adhesion minimum of 2.0 pounds per linear inch (PLI). Test patches will be conducted with Part A only (uncatalyzed) and will be applied with enough material to embed the fabric.
2. Power-wash substrate to remove contaminants that could negatively affect adhesion. Allow roof to completely dry.
3. Prime per chart below.
4. Treat "alligatored" areas, surface cracks, roof penetrations, drains, curbs and scuppers. (Refer to Substrate Preparation section for requirements)
5. All loose seams must be 3-coursed. All other seams must be treated with flashing grade only, no fabric required. (Refer to Seam Treatment Guide for requirements)
6. This is a two-part product that will be applied via a specialized CJ sprayer, where the product will be catalyzed as it is sprayed.
7. Apply the catalyzed coating per the chart below:

#### CLEAN / PRIME

	Product	Rate (Gal/Sq)
Cleaner	UCC Cleaner	0.5 - 0.7
Primer	Roof Mate™ MB Plus	1.0

#### SEAMS & DETAILS<sup>1</sup>

Treatment Type	Product	Total (Gal/Sq)	DFT* (mils)
3-Coursed Rates	Roof Mate™ Butter Grade and Fabric	4.0	43
Flashing Grade Only Rates	Roof Mate™ Butter Grade	2.0	19

\* Dry Film Thickness (DFT) is rounded to nearest mil, and is theoretical. Actual DFT will vary dependent on substrate profile, application technique and waste factor.

Note: DFT for 3-coursed rates includes 6 mils for the fabric.

Note: For other product options, please refer to our Seam Treatment Guide.

<sup>1</sup>Flashing rates are based on a 6" (152 mm) width, rates will double for 12" (305 mm) width.

#### Tip Combination for CJ's Sprayer (Coating pressure range: 850 - 1000 psi & Catalyst pressure @ 100 psi)

Choose the temperature and humidity closest to current conditions to find an initial tip combinations.	Temperature, °F			
	Hot (80°F-100°F) (26°C-37°C)	Moderate (65°F-80°F) (18°C-26°C)	Cold (50°F-65°F) (10°C-18°C)	
Humidity, %	Humid (50%-80%)	561/9502 (557/9502)	561/9502 (557/9502)	561/9502 (557/9502)
	Moderate (30%-50%)	565/9502 (561/9502)	561/9502 (557/9502)	561/9502 (557/9502)
	Dry (15%-30%)	565/9502 (561/9502)	561/9502 (557/9502)	561/9502 (557/9502)

#### Note: (Coating Tip/Catalyst Tip)

Tip combination and coating pressure need to be optimized based on actual ambient condition, wind speed, elevation, and length of the spray hose. For best results, conduct a spray test in current conditions to confirm appropriate tip combinations and coating pressure settings. This chart is only intended to serve as an estimated initial starting point.

### GRANULATED ASPHALTIC ROOFSHIELD® I.S.

Coverage Term	Coating		Warranty/Guarantee**	
	1st Coat (Gal/Sq)	DFT* (mils)	Emerald Pledge™	Diamond Pledge™
10 Year	3.0	25	Yes**	No

\*\* Contractors must receive specialized training on the CJ Spray equipment for enhanced system warranties or guarantees. Contact Technical Support Services for more information.

# ROOFSHIELD® I.S. QUICK SPEC

## STRUCTURAL CONCRETE (RS-6)

**RST  
SPRAYER**

**NOTE:** The following “Quick Spec” is an abbreviated specification and is not meant to replace the detailed specification. Complete 3-part CSI System Specifications are available at [www.gaf.com](http://www.gaf.com).

### METHOD REQUIREMENTS

#### Required:

- Moisture survey required (Must contain less than 8% moisture)
- Concrete must be fully cured
- Roof must be clean, dry and tight
- Repair deteriorated sections with like materials (Allow repairs to cure properly)
- Adhesion test required
- Power washing required
- No rain, dew, fog, or freezing temperatures in forecast for 24 hours
- Refer to Technical Data Sheet for product specific application and surface temperature restrictions

#### Installation Overview:

1. Before coating is applied, an adhesion test is required to ensure an adhesion minimum of 2.0 pounds per linear inch (PLI). Test patches will be conducted with Part A only

- (uncatalyzed) over the primer and should be applied with enough material to embed the fabric.
2. Power-wash substrate to remove contaminants that could negatively affect adhesion. Allow roof to completely dry.
3. Prime per chart below.
4. Treat all roof penetrations, drains, curbs, and scuppers. (Refer to Substrate Preparation section for requirements)
5. Treat structural joints with backer rod and compatible sealant, prior to seam treatment. (Refer to Seam Treatment Guide for requirements)
6. Control joints and transite gaps in excess of 1/16" (1.6 mm) shall also be caulked with a compatible caulk.
7. This is a two-part product that will be applied via a specialized RST sprayer, where the product will be catalyzed as it is sprayed.
8. Apply the catalyzed coating per the chart below:

#### CLEAN / PRIME

	Product	Rate (Gal/Sq)
Cleaner	UCC Cleaner	0.5 - 0.7
Primer	Epoxy Primer	0.3 - 0.4

#### SEAMS & DETAILS<sup>1</sup>

Treatment Type	Product	Total (Gal/Sq)	DFT* (mils)
3-Coursed Rates	Roof Mate™ Butter Grade and Fabric	4.0	43
Flashing Grade Only Rates	Roof Mate™ Butter Grade	2.0	19

\* Dry Film Thickness (DFT) is rounded to nearest mil, and is theoretical. Actual DFT will vary dependent on substrate profile, application technique and waste factor.  
 Note: DFT for 3-coursed rates includes 6 mils for the fabric.  
 Note: For other product options, please refer to our Seam Treatment Guide.  
<sup>1</sup>Flashing rates are based on a 6" (152 mm) width, rates will double for 12" (305 mm) width.

#### RST Sprayer Catalyst Pressure Settings<sup>◇</sup> (PSI) for Different Temperature-Humidity Conditions

Choose the temperature and humidity closest to current conditions to find an initial catalyst pressure setting <sup>◇</sup> .	Temperature, °F			
	Hot (80°F-100°F)	Moderate (65°F-80°F)	Cold (50°F-65°F)	
Humidity, %	Humid (50%-80%)	50	60	70
	Moderate (30%-50%)	45	50	60
	Dry (15%-30%)	40	45	50

<sup>◇</sup> Catalyst pressure needs to be optimized based on actual ambient condition, wind speed, and elevation. For best results, conduct a spray test in current conditions to confirm appropriate catalyst settings. This chart is only intended to serve as an estimated initial starting point.

#### STRUCTURAL CONCRETE ROOFSHIELD® I.S.

Coverage Term	Coating		Warranty/Guarantee**	
	1st Coat (Gal/Sq)	DFT* (mils)	Emerald Pledge™	Diamond Pledge™
10 Year	3.0	25	Yes**	No

\*\* Contractors must receive specialized training on the RST Spray equipment for enhanced system warranties or guarantees. Contact Technical Support Services for more information.



# ROOFSHIELD® I.S. QUICK SPEC

## STRUCTURAL CONCRETE (RS-6)

**CJ  
SPRAYER**

**NOTE:** The following "Quick Spec" is an abbreviated specification and is not meant to replace the detailed specification. Complete 3-part CSI System Specifications are available at [www.gaf.com](http://www.gaf.com).



### METHOD REQUIREMENTS

#### Required:

- Moisture survey required (Must contain less than 8% moisture)
- Concrete must be fully cured
- Roof must be clean, dry and tight
- Repair deteriorated sections with like materials (Allow repairs to cure properly)
- Adhesion test required
- Power washing required
- No rain, dew, fog, or freezing temperatures in forecast for 24 hours
- Refer to Technical Data Sheet for product specific application and surface temperature restrictions

#### Installation Overview:

1. Before coating is applied, an adhesion test is required to ensure an adhesion minimum of 2.0 pounds per linear inch (PLI). Test patches will be conducted with Part A only

2. Power-wash substrate to remove contaminants that could negatively affect adhesion. Allow roof to completely dry.
3. Prime per chart below.
4. Treat all roof penetrations, drains, curbs, and scuppers. (Refer to Substrate Preparation section for requirements)
5. Treat structural joints with backer rod and compatible sealant, prior to seam treatment. (Refer to Seam Treatment Guide for requirements)
6. Control joints and transite gaps in excess of 1/16" (1.6 mm) shall also be caulked with a compatible caulk.
7. This is a two-part product that will be applied via a specialized CJ sprayer, where the product will be catalyzed as it is sprayed.
8. Apply the catalyzed coating per the chart below:

#### CLEAN / PRIME

	Product	Rate (Gal/Sq)
Cleaner	UCC Cleaner	0.5 - 0.7
Primer	Epoxy Primer	0.3 - 0.4

#### SEAMS & DETAILS<sup>1</sup>

Treatment Type	Product	Total (Gal/Sq)	DFT* (mils)
3-Coursed Rates	Roof Mate™ Butter Grade and Fabric	4.0	43
Flashing Grade Only Rates	Roof Mate™ Butter Grade	2.0	19

\* Dry Film Thickness (DFT) is rounded to nearest mil, and is theoretical. Actual DFT will vary dependent on substrate profile, application technique and waste factor.  
 Note: DFT for 3-coursed rates includes 6 mils for the fabric.  
 Note: For other product options, please refer to our Seam Treatment Guide.  
<sup>1</sup>Flashing rates are based on a 6" (152 mm) width, rates will double for 12" (305 mm) width.

#### Tip Combination for CJ's Sprayer (Coating pressure range: 850 - 1000 psi & Catalyst pressure @ 100 psi)

Choose the temperature and humidity closest to current conditions to find an initial tip combinations.	Temperature, °F			
	Hot (80°F-100°F) (26°C-37°C)	Moderate (65°F-80°F) (18°C-26°C)	Cold (50°F-65°F) (10°C-18°C)	
Humidity, %	Humid (50%-80%)	561/9502 (557/9502)	561/9502 (557/9502)	561/9502 (557/9502)
	Moderate (30%-50%)	565/9502 (561/9502)	561/9502 (557/9502)	561/9502 (557/9502)
	Dry (15%-30%)	565/9502 (561/9502)	561/9502 (557/9502)	561/9502 (557/9502)

#### Note: (Coating Tip/Catalyst Tip)

Tip combination and coating pressure need to be optimized based on actual ambient condition, wind speed, elevation, and length of the spray hose. For best results, conduct a spray test in current conditions to confirm appropriate tip combinations and coating pressure settings. This chart is only intended to serve as an estimated initial starting point.

### STRUCTURAL CONCRETE ROOFSHIELD® I.S.

Coverage Term	Coating		Warranty/Guarantee**	
	1st Coat (Gal/Sq)	DFT* (mils)	Emerald Pledge™	Diamond Pledge™
10 Year	3.0	25	Yes**	No

\*\* Contractors must receive specialized training on the CJ Spray equipment for enhanced system warranties or guarantees. Contact Technical Support Services for more information.

# ROOFSHIELD® I.S. QUICK SPEC

## CORRUGATED STRUCTURAL TRANSITE PANELS (RS-7)

**RST  
SPRAYER**

**NOTE:** The following "Quick Spec" is an abbreviated specification and is not meant to replace the detailed specification. Complete 3-part CSI System Specifications are available at [www.gaf.com](http://www.gaf.com).

### METHOD REQUIREMENTS

#### Required:

- Moisture survey required
- Roof must be clean, dry, and tight
- Adhesion test required
- Power washing required
- No rain, dew, fog or freezing temperatures in forecast for 24 hours
- Refer to Technical Data Sheet for product specific application and surface temperature restrictions

#### Installation Overview:

1. Before coating is applied, an adhesion test is required to ensure an adhesion minimum of 2.0 pounds per linear inch (PLI). Test patches will be conducted with Part A only (uncatalyzed) over the primer and should be applied with enough material to embed the fabric.

2. Power-wash substrate to remove contaminants that could negatively affect adhesion. Allow roof to completely dry.
3. Prime per chart below.
4. Tighten/replace existing fasteners. Encapsulate with appropriate flashing material.
5. Treat transite gaps in excess of 1/16" (1.6 mm) with compatible caulk.
6. Treat all roof penetrations, drains, curbs, and scuppers. (Refer to Substrate Preparation section for requirements)
7. This is a two-part product that will be applied via a specialized RST sprayer, where the product will be catalyzed as it is sprayed.
8. Apply the catalyzed coating per the chart below:

#### CLEAN / PRIME

	Product	Rate (Gal/Sq)
Cleaner	UCC Cleaner	0.5 - 0.7
Primer	Epoxy Primer	0.3 - 0.4

#### SEAMS & DETAILS<sup>1</sup>

Treatment Type	Product	Total (Gal/Sq)	DFT* (mils)
3-Coursed Rates	Roof Mate™ Butter Grade and Fabric	4.0	43
Flashing Grade Only Rates	Roof Mate™ Butter Grade	2.0	19

\* Dry Film Thickness (DFT) is rounded to nearest mil, and is theoretical. Actual DFT will vary dependent on substrate profile, application technique and waste factor.  
 Note: DFT for 3-coursed rates includes 6 mils for the fabric.  
 Note: For other product options, please refer to our Seam Treatment Guide.  
<sup>1</sup>Flashing rates are based on a 6" (152 mm) width, rates will double for 12" (305 mm) width.

#### RST Sprayer Catalyst Pressure Settings<sup>◇</sup> (PSI) for Different Temperature-Humidity Conditions

Choose the temperature and humidity closest to current conditions to find an initial catalyst pressure setting <sup>◇</sup> .	Temperature, °F			
	Hot (80°F-100°F)	Moderate (65°F-80°F)	Cold (50°F-65°F)	
Humidity, %	Humid (50%-80%)	50	60	70
	Moderate (30%-50%)	45	50	60
	Dry (15%-30%)	40	45	50

<sup>◇</sup> Catalyst pressure needs to be optimized based on actual ambient condition, wind speed, and elevation. For best results, conduct a spray test in current conditions to confirm appropriate catalyst settings. This chart is only intended to serve as an estimated initial starting point.

### CORRUGATED STRUCTURAL TRANSITE PANELS ROOFSHIELD® I.S.

Coverage Term	Coating		Warranty/Guarantee**	
	1st Coat (Gal/Sq)	DFT* (mils)	Emerald Pledge™	Diamond Pledge
10 Year	3.0	25	Yes**	No

\*\* Contractors must receive specialized training on the RST Spray equipment for enhanced system warranties or guarantees. Contact Technical Support Services for more information.

**Important Note:** Corrugated structural transite panels may contain asbestos. Follow all applicable local, state and federal regulations concerning asbestos. Under no circumstances does GAF have any liability for any damages, costs or expenses arising out of or associated with the pre-existing presence of asbestos-containing materials or any other allegedly hazardous substance or materials upon on the roof to which the new GAF roofing materials are being applied.

# ROOFSHIELD® I.S. QUICK SPEC

## CORRUGATED STRUCTURAL TRANSITE PANELS (RS-7)

CJ  
SPRAYER

**NOTE:** The following "Quick Spec" is an abbreviated specification and is not meant to replace the detailed specification. Complete 3-part CSI System Specifications are available at [www.gaf.com](http://www.gaf.com).



### METHOD REQUIREMENTS

#### Required:

- Moisture survey required
- Roof must be clean, dry, and tight
- Adhesion test required
- Power washing required
- No rain, dew, fog or freezing temperatures in forecast for 24 hours
- Refer to Technical Data Sheet for product specific application and surface temperature restrictions

#### Installation Overview:

1. Before coating is applied, an adhesion test is required to ensure an adhesion minimum of 2.0 pounds per linear inch (PLI). Test patches will be conducted with Part A only (uncatalyzed) over the primer and will be applied with enough material to embed the fabric.

2. Power-wash substrate to remove contaminants that could negatively affect adhesion. Allow roof to completely dry.
3. Prime per chart below.
4. Tighten/replace existing fasteners. Encapsulate with appropriate flashing material.
5. Treat transite gaps in excess of 1/16" (1.6 mm) with compatible caulk.
6. Treat all roof penetrations, drains, curbs, and scuppers. (Refer to Substrate Preparation section for requirements)
7. This is a two-part product that will be applied via a specialized CJ sprayer, where the product will be catalyzed as it is sprayed.
8. Apply the catalyzed coating per the chart below:

#### CLEAN / PRIME

	Product	Rate (Gal/Sq)
Cleaner	UCC Cleaner	0.5 - 0.7
Primer	Epoxy Primer	0.3 - 0.4

#### SEAMS & DETAILS<sup>1</sup>

Treatment Type	Product	Total (Gal/Sq)	DFT* (mils)
3-Coursed Rates	Roof Mate™ Butter Grade and Fabric	4.0	43
Flashing Grade Only Rates	Roof Mate™ Butter Grade	2.0	19

\* Dry Film Thickness (DFT) is rounded to nearest mil, and is theoretical. Actual DFT will vary dependent on substrate profile, application technique and waste factor.  
 Note: DFT for 3-coursed rates includes 6 mils for the fabric.  
 Note: For other product options, please refer to our Seam Treatment Guide.  
<sup>1</sup>Flashing rates are based on a 6" (152 mm) width, rates will double for 12" (305 mm) width.

#### Tip Combination for CJ's Sprayer (Coating pressure range: 850 - 1000 psi & Catalyst pressure @ 100 psi)

Choose the temperature and humidity closest to current conditions to find an initial tip combinations.	Temperature, °F			
	Hot (80°F-100°F) (26°C-37°C)	Moderate (65°F-80°F) (18°C-26°C)	Cold (50°F-65°F) (10°C-18°C)	
Humidity, %	Humid (50%-80%)	561/9502 (557/9502)	561/9502 (557/9502)	561/9502 (557/9502)
	Moderate (30%-50%)	565/9502 (561/9502)	561/9502 (557/9502)	561/9502 (557/9502)
	Dry (15%-30%)	565/9502 (561/9502)	561/9502 (557/9502)	561/9502 (557/9502)

#### Note: (Coating Tip/Catalyst Tip)

Tip combination and coating pressure need to be optimized based on actual ambient condition, wind speed, elevation, and length of the spray hose. For best results, conduct a spray test in current conditions to confirm appropriate tip combinations and coating pressure settings. This chart is only intended to serve as an estimated initial starting point.

### CORRUGATED STRUCTURAL TRANSITE PANELS ROOFSHIELD® I.S.

Coverage Term	Coating		Warranty/Guarantee**	
	1st Coat (Gal/Sq)	DFT* (mils)	Emerald Pledge™	Diamond Pledge
10 Year	3.0	25	Yes**	No

\*\* Contractors must receive specialized training on the CJ Spray equipment for enhanced system warranties or guarantees. Contact Technical Support Services for more information.

**Important Note:** Corrugated structural transite panels may contain asbestos. Follow all applicable local, state and federal regulations concerning asbestos. Under no circumstances does GAF have any liability for any damages, costs or expenses arising out of or associated with the pre-existing presence of asbestos-containing materials or any other allegedly hazardous substance or materials upon on the roof to which the new GAF roofing materials are being applied.

# ROOFSHIELD® I.S. QUICK SPEC

## METAL (RS-8)

**RST  
SPRAYER**

**NOTE:** The following "Quick Spec" is an abbreviated specification and is not meant to replace the detailed specification. Complete 3-part CSI System Specifications are available at [www.gaf.com](http://www.gaf.com).



### METHOD REQUIREMENTS

#### Required:

- Roof must be clean, dry, and tight
- Adhesion test required
- Power washing required
- No rain, dew, fog or freezing temperatures in forecast for 24 hours
- Refer to Technical Data Sheet for product specific application and surface temperature restrictions

#### Installation Overview:

1. Before coating is applied, an adhesion test is required to ensure an adhesion minimum of 2.0 pounds per linear inch (PLI). Test patches will be conducted with Part A only (uncatalyzed) over the primer and should be applied with enough material to embed the fabric.
2. Tighten/replace existing fasteners. Encapsulate with appropriate flashing material.
3. Power-wash substrate to remove contaminants that could negatively affect adhesion. Allow roof to completely dry.

4. Install crickets to divert water and complete other necessary sheet metal repairs.
5. **MUST** prime per chart below. ALL metal surfaces must be completely covered by a primer before proceeding with coating application.
6. Horizontal seams must be 3-coursed. Overlap and trapezoidal vertical seams must be treated with flashing grade only. Other vertical seams may forgo treatment **IF** the seal/tape is intact on the seam or if they are double locked. (Refer to Seam Treatment Guide for requirements)
7. Treat all roof penetrations, skylight curbs and rake edges. (Refer to Substrate Preparation section for requirements)
8. This is a two-part product that will be applied via a specialized RST sprayer, where the product will be catalyzed as it is sprayed.
9. Apply the catalyzed coating per the chart below:

#### CLEAN / PRIME

	Product	Rate (Gal/Sq)
Cleaner	UCC Cleaner	0.5 - 0.7
Primer	Acrylex 400	0.3 - 0.4
	Lock Down Primer	0.3 - 0.4

#### SEAMS & DETAILS<sup>1</sup>

Treatment Type	Product	Total (Gal/Sq)	DFT* (mils)
3-Coursed Rates	Roof Mate™ Butter Grade and Fabric	4.0	43
Flashing Grade Only Rates	Roof Mate™ Butter Grade	2.0	19

\* Dry Film Thickness (DFT) is rounded to nearest mil, and is theoretical. Actual DFT will vary dependent on substrate profile, application technique and waste factor.  
 Note: DFT for 3-coursed rates includes 6 mils for the fabric.  
 Note: For other product options, please refer to our Seam Treatment Guide.  
<sup>1</sup>Flashing rates are based on a 6" (152 mm) width, rates will double for 12" (305 mm) width.

#### RST Sprayer Catalyst Pressure Settings<sup>◇</sup> (PSI) for Different Temperature-Humidity Conditions

Choose the temperature and humidity closest to current conditions to find an initial catalyst pressure setting <sup>◇</sup> .	Temperature, °F			
	Hot (80°F-100°F)	Moderate (65°F-80°F)	Cold (50°F-65°F)	
Humidity, %	Humid (50%-80%)	50	60	70
	Moderate (30%-50%)	45	50	60
	Dry (15%-30%)	40	45	50

<sup>◇</sup> Catalyst pressure needs to be optimized based on actual ambient condition, wind speed, and elevation. For best results, conduct a spray test in current conditions to confirm appropriate catalyst settings. This chart is only intended to serve as an estimated initial starting point.

#### METAL ROOFSHIELD® I.S.

Coverage Term	Coating		Warranty/Guarantee**	
	1st Coat (Gal/Sq)	DFT* (mils)	Emerald Pledge™	Diamond Pledge™
10 Year	3.0	25	Yes**	No

\*\* Contractors must receive specialized training on the RST Spray equipment for enhanced system warranties or guarantees. Contact Technical Support Services for more information.

# ROOFSHIELD® I.S. QUICK SPEC

## METAL (RS-8)

CJ  
SPRAYER

**NOTE:** The following "Quick Spec" is an abbreviated specification and is not meant to replace the detailed specification. Complete 3-part CSI System Specifications are available at [www.gaf.com](http://www.gaf.com).

### METHOD REQUIREMENTS

#### Required:

- Roof must be clean, dry, and tight
- Adhesion test required
- Power washing required
- No rain, dew, fog or freezing temperatures in forecast for 24 hours
- Refer to Technical Data Sheet for product specific application and surface temperature restrictions

#### Installation Overview:

1. Before coating is applied, an adhesion test is required to ensure an adhesion minimum of 2.0 pounds per linear inch (PLI). Test patches will be conducted with Part A only (uncatalyzed) over the primer and will be applied with enough material to embed the fabric.
2. Tighten/replace existing fasteners. Encapsulate with appropriate flashing material.
3. Power-wash substrate to remove contaminants that could negatively affect adhesion. Allow roof to completely dry.
4. Install crickets to divert water and complete other necessary sheet metal repairs.
5. MUST prime per chart below. ALL metal surfaces must be completely covered by a primer before proceeding with coating application.
6. Horizontal seams must be 3-coursed. Overlap and trapezoidal vertical seams must be treated with flashing grade only. Other vertical seams may forgo treatment **IF** the seal/tape is intact on the seam or if they are double locked. (Refer to Seam Treatment Guide for requirements)
7. Treat all roof penetrations, skylight curbs and rake edges. (Refer to Substrate Preparation section for requirements)
8. This is a two-part product that will be applied via a specialized CJ sprayer, where the product will be catalyzed as it is sprayed.
9. Apply the catalyzed coating per the chart below:

#### CLEAN / PRIME

	Product	Rate (Gal/Sq)
Cleaner	UCC Cleaner	0.5 - 0.7
Primer	Acrylex 400	0.3 - 0.4
	Lock Down Primer	0.3 - 0.4

#### SEAMS & DETAILS<sup>1</sup>

Treatment Type	Product	Total (Gal/Sq)	DFT* (mils)
3-Coursed Rates	Roof Mate™ Butter Grade and Fabric	4.0	43
Flashing Grade Only Rates	Roof Mate™ Butter Grade	2.0	19

\* Dry Film Thickness (DFT) is rounded to nearest mil, and is theoretical. Actual DFT will vary dependent on substrate profile, application technique and waste factor.  
 Note: DFT for 3-coursed rates includes 6 mils for the fabric.  
 Note: For other product options, please refer to our Seam Treatment Guide.  
<sup>1</sup>Flashing rates are based on a 6" (152 mm) width, rates will double for 12" (305 mm) width.

#### Tip Combination for CJ's Sprayer (Coating pressure range: 850 - 1000 psi & Catalyst pressure @ 100 psi)

Choose the temperature and humidity closest to current conditions to find an initial tip combinations.	Temperature, °F			
	Hot (80°F-100°F) (26°C-37°C)	Moderate (65°F-80°F) (18°C-26°C)	Cold (50°F-65°F) (10°C-18°C)	
Humidity, %	Humid (50%-80%)	561/9502 (557/9502)	561/9502 (557/9502)	561/9502 (557/9502)
	Moderate (30%-50%)	565/9502 (561/9502)	561/9502 (557/9502)	561/9502 (557/9502)
	Dry (15%-30%)	565/9502 (561/9502)	561/9502 (557/9502)	561/9502 (557/9502)

**Note: (Coating Tip/Catalyst Tip)**

Tip combination and coating pressure need to be optimized based on actual ambient condition, wind speed, elevation, and length of the spray hose. For best results, conduct a spray test in current conditions to confirm appropriate tip combinations and coating pressure settings. This chart is only intended to serve as an estimated initial starting point.

### METAL ROOFSHIELD® I.S.

Coverage Term	Coating		Warranty/Guarantee**	
	1st Coat (Gal/Sq)	DFT* (mils)	Emerald Pledge™	Diamond Pledge™
10 Year	3.0	25	Yes**	No

\*\* Contractors must receive specialized training on the CJ Spray equipment for enhanced system warranties or guarantees. Contact Technical Support Services for more information.

# **SECTION 4**

## Care & Preventative Maintenance

## OVERVIEW

Due to its constant exposure to heat, cold, ultraviolet rays, rain, snow, hail, high winds and/or physical damage, a roof can be the one of the most vulnerable component of a building's exterior. Despite exposure to these negative effects, long-term performance can be enhanced, and major roof problems can be mitigated or avoided, through correct design, quality materials, proper installation procedures and workmanship, and a comprehensive roof maintenance program. The cost of a comprehensive maintenance program is minimal compared to the cost of repairing and/or replacing a damaged roofing system.

The roofing system is a critical asset in the overall building envelope, and should be treated as such. Identifying and correcting potential problems early is important to help prevent small problem from becoming bigger issues. It helps to maintain the integrity of the roof, protect the building's contents, and avoid interruption of the building's intended function. A thorough and consistent maintenance schedule can also help extend the life of the roofing system and lower life cycle and replacement costs.

## UNDERSTANDING THE IMPORTANCE OF PROPER ROOF MAINTENANCE AND REPAIR

Like all roofing systems, roofs that have been coated require regular maintenance and repair. The Roof Coatings Manufacturers Association (RCMA) recommends that roofs and coatings be inspected twice each year, generally in the spring and fall, and after any major storms or high speed wind events. Additional coating should be applied as necessary to repair damage to the coating or underlying roofing substrate. Additional coating can also be applied where the existing coating has worn away. Refer to the specific sections of this manual for more information on coating and re-coating applications.

## GENERAL CARE & PREVENTATIVE MAINTENANCE

The following is a list of general care and maintenance recommendations that will help achieve maximum performance from the roofing system.

- Provide proper drainage to minimize standing water on the roof. Keep the roof surface clean from leaves, pine needles, twigs, paper, accumulated dirt and other debris, which may accumulate and result in clogged drains. Cut back trees or branches growing too close to the roof.
- Ponding water on the surface of the roofing system will increase the probability of moisture entering the structure in the event of a puncture or other mechanical damage to the roofing membrane.
- Check the building exterior for settlement or movement. Cracks in the walls are a warning of possible cracks in the roof substrate and flashing. Ensure that overhangs, cornices, fascia, and edging are in good condition.
- Avoid damaging the roofing system by exposing it to any of the following, which could cause premature degradation of the coating or membrane:
  - Liquids containing petroleum products
  - Solvents
  - Grease used for lubricating rooftop units or from restaurant vents
  - Oils (new or old) used for air conditioning or compressor units
  - Kitchen waste or other animal fats
  - Chemicals
- The use of catch pans (including proper drainage of these pans or other means of protection) may be used to protect the roofing membrane from exposure to grease, chemicals, and other materials that would otherwise be expelled onto the roof surface. Prolonged exposure to these materials can cause swelling and possible degradation of the roofing system if spills are not removed in a timely manner.
- Check for signs of algae, mold, mildew or other plant growth on the roof, particularly in shaded areas that hold water.
- Unprotected areas of the roofing system are more susceptible to damage from heavy foot traffic and additional measures must be taken to avoid damage to the system. See options below and/or contact GAF for recommendations where heavy foot traffic is expected.
- If snow removal is necessary, use plastic shovels and be careful when working around protrusions or other areas where detail work could be damaged. Snow blowers, picks, axes and shovels with sharp edges must not be used on the roof.
- Remove foreign debris, such as glass, bolts, nails, screws, metal shavings, and any other materials that may cause punctures or cuts to the liquid-applied coating or roofing system.
- Limit roof access. Most roof damage is caused by individuals that are not authorized to access the roof, or by individuals that are not aware of the damage that can be caused when proper precautionary procedures are not followed. Roof access should be strictly limited to authorized personnel and outside personnel should be informed as to the precautions necessary when accessing the roof. Make a log of all visitors and

maintenance personnel accessing the roof.

- Make sure that maintenance personnel are warned against dropping tools and equipment on the coated roof surface in order to avoid puncturing the membrane. When servicing the rooftop HVAC units, antennas, solar panels, satellite dishes, etc., care should be taken when placing tools, metal doors, lids, pans, or sharp objects on the coating system surface. When moving roof-mounted units or equipment over coated roofs, avoid damage by placing smooth plywood over the coating membrane prior to moving any equipment.
- Repair of any damage caused by physical damage to the roofing system is the responsibility of the Building Owner. The Building Owner is also responsible for ensuring that any such damage is properly repaired by either the original contractor of record or another GAF-certified contractor. If timely repairs are not made to rectify physical damage to the roofing system, this can result in the need for major repairs or replacement of the roof or roof coating system at the Building Owner's sole expense.

## SEMI-ANNUAL INSPECTIONS

When conducting a semi-annual inspection, the liquid-applied coating may be slippery when wet. Exercise caution when walking on the liquid-applied roofing system or coating during or after a rain shower, or if moisture is present in the form of dew, frost or ice. Pay attention while walking on light-colored surfaces as ice or frost build-up may not be as visible as on a dark surface.

### Semi-Annual Inspections...

Consist of a cleaning and visual examination of the roof coating system. The inspection should include the overall coating condition as well as the integrity of flashings, vent pipes and other protrusions, skylights, drains, gutters, parapet walls and caps, adjacent walls, and mechanical equipment. Also check for evidence of any biological growth or other foreign debris.

### Preventative Maintenance Program...

Consists of regularly scheduled inspections and subsequent corrective actions, intended to maximize the life expectancy of the roofing system. It is recommended that preventative maintenance semi-annual inspections be scheduled in the spring and fall.

### Additional Inspections

In addition to the scheduled semi-annual inspection, additional inspections should be scheduled if the roof is exposed to physical damage unusual conditions including but not limited to those listed below. Maintenance programs that include semi-annual inspections can usually be arranged through the installing contractor or another GAF-certified contractor. They can also be performed by a registered roof consultant or other qualified personnel who have been properly trained in liquid-applied coating systems and safety. These inspections should be attended by the Building Owner and/or in-house maintenance personnel responsible for the roof. Additional roof inspections should be conducted whenever any of the following conditions occur:

1. Exposure of the roof to severe weather, such as strong winds, hail or continuous heavy rainfall.
  - Examine the roof for severely ponded areas, accumulated debris, and any damage to the building components that may allow moisture to infiltrate the roofing membrane. The coating or liquid-applied system should also be examined in areas where severe conditions may have caused punctures, tears, abrasions or loose coating.
2. After repair or replacement of rooftop equipment, or at any other time when the roof may be exposed to activities from other trades where damage may occur.
  - Examine the roof for spills, debris, sharp objects, punctures, excessive wear, or other damage caused by heavy traffic or modifications to the roof.

### Cleaning Procedures

**WARNING:** The liquid-applied coating may be slippery when wet. Exercise caution when walking on the liquid-applied coating system during cleaning.

1. Remove any build-up of rocks, branches, leaves, pine needles and other foreign debris, as well as excessive dirt build-up around drains and other low areas. Use a plastic rake, medium-bristle push brush or other appropriate method for removing this accumulated debris from the roof, using the least amount of pressure possible. Remove any excessive build-up or blockage from drains, gutters and downspouts. Ensure that downspouts on multi-level roofs do not dump directly onto the coated roof surface below. Trim any overhanging trees to prevent excessive leaf and pine needle accumulation, allowing as much sunlight to the roof as possible to help eliminate mildew and algae growth.



2. Liberally apply GAF United Cleaning Concentrate (UCC), diluted at a ratio of 1 part concentrate to 10 parts water, under low pressure to a given section of the roof at the rate of 0.4 to 0.7 gallons per 100 ft<sup>2</sup> (1.6 to 2.9 L/m<sup>2</sup>). Allow the cleaner to sit for a minimum of 15 minutes.
3. Make sure that areas where algae, mold, or mildew growth has occurred are thoroughly saturated. These areas should also receive additional scrubbing with a medium to stiff bristle brush to assure the most complete removal possible.
4. Pressure rinse toward the drains using clean water and a 1,200 to 1,500 psi pressure washer. Use a fan tip on the extension wand, held no closer than 12" (305 mm) from the coated roof surface. Low areas where the dirt has accumulated may require additional agitation using a broom or cleaning pad.

**IMPORTANT:** Roof wash-off catchment systems should be in place when required. Be sure to follow state and local requirements for roof-wash off catchments during the cleaning process.

# INSPECTION CHECKLIST

## Pre-Inspection

Prior to the actual roof inspection, a detailed roof plan should be prepared, on which any defects and notes can be recorded.

Prior to going onto the roof itself, inspect the underside of the deck (if accessible), as well as the outside of the building. Note any signs of excessive moisture, staining, or deterioration. These observations can give clues to not only problems with the roof, but also other conditions affecting the performance of the building envelope.

### GAF Inspection Checklist

Area of Concern	Treatment	✓
<b>Roof Membrane &amp; Flashings</b>	<ul style="list-style-type: none"> <li>Ensure that the overall roof coating membrane is sound and free of mechanical damage, splits, crazing, and cracking. In areas prone to standing water, inspect the coating surface for signs of blisters, delamination, or degradation caused by biological growth.</li> </ul>	
<b>Roof Drains &amp; Scuppers</b>	<ul style="list-style-type: none"> <li>Ensure that roof drains and scuppers are clear and free of all debris to allow for proper drainage. Check drain covers to verify that they are tight and properly fastened. Ensure that the coating around drains and scuppers is sound and free of blisters, tears, and delaminations.</li> </ul>	
<b>Gutters</b>	<ul style="list-style-type: none"> <li>Ensure that gutters are clean and free of any debris that will inhibit proper drainage. If drains are coated, inspect coating to ensure that it is sound and free of blisters, tears and delaminations.</li> </ul>	
<b>Parapet Walls &amp; Caps</b>	<ul style="list-style-type: none"> <li>Inspect interface between roof deck and parapet walls to ensure that there are no splits or tears, and that the coating membrane is fully-adhered and sound. Examine parapet walls and caps to ensure that there are no cracks or breaks in the substrate or membrane that will allow moisture to enter beneath the coating system.</li> </ul>	
<b>Protrusions</b>	<ul style="list-style-type: none"> <li>Inspect the reinforced coating around all protrusions, such as vent pipes, for any signs of splits, tears or delaminations around the base. Ensure that vent pipes have the proper caps installed. Inspect coating to ensure that it is still self-flashing and secure around the top of all protrusions.</li> </ul>	
<b>Roof Mounted Equipment</b>	<ul style="list-style-type: none"> <li>All rooftop equipment should be inspected to ensure that it is well-secured to the base risers, and that the coating and reinforcement around the base is sound and free of blisters, tears and delaminations.</li> </ul>	
<b>Skylights</b>	<ul style="list-style-type: none"> <li>Check the reinforcement around all skylights to ensure that it is sound and free of blisters, tears and delaminations.</li> </ul>	
<b>Other Details</b>	<ul style="list-style-type: none"> <li>Check the bricks and mortar on chimneys, as well as caulking or joints in metal flashings such as copings, counter-flashings, rooftop units, curbs, caps, expansion joints, etc. Repair or replace caulking as necessary.</li> </ul>	
<b>Moisture Analysis (optional)</b>	<ul style="list-style-type: none"> <li>If damage has caused concern with moisture penetration into the roof substrate, a non-destructive moisture detection survey can be conducted to provide an accurate analysis. Two common methods are nuclear metering and infrared thermography. A moisture meter probe can also be inserted through the coating; however, this is a destructive method and will require the damage be repaired.</li> </ul>	
<b>Minor Repairs</b>	<ul style="list-style-type: none"> <li>Areas found to need minor repairs (e.g., small punctures and tears) during the inspection may be repaired with Roof Mate™ Butter Grade. More extensive repairs may be treated with Roof Mate™ Butter Grade product with fabric. For project-specific recommendations, please contact GAF's Technical Services.</li> </ul>	

## ROOF SPECIFIC LEAK INVESTIGATION

On metal decks, it is important to identify the direction of the deck flutes and deck slope. Moisture may infiltrate through the roofing system, migrate in the lower flutes of the deck, and leak inside the building in low areas.

On concrete decks or on projects where the existing roofing material is left in place, leaks may result from moisture entrapment in the original installation.

On poorly insulated roofing assemblies, leaks may occur as the result of condensation. It is therefore important to determine the leak location and frequency. Sources of air leakage should be sealed if possible.

1. Begin leak investigations by conducting a thorough visual inspection of the general location on the roof where leaks have been detected inside the building.
2. Inspect detail areas such as drains, vents, scuppers, HVAC and other roof-mounted equipment, parapets, ponded water areas, etc. If the roof is dry at the time of investigation, areas where water ponds can be identified by evidence of accumulated residue on roof membrane.
3. Examine lower areas of the roof for moisture beneath the roof coating system (soft insulation can be detected when walking over the roof).
4. Check areas around mechanical rooftop equipment, drains, skylights, roof hatches, expansion joints, pipes, vents, etc. to identify cuts or punctures in the coating membrane.
5. Examine the condition of metal flashings (i.e., edging, coping, expansion joint covers, parapet caps, etc.) for cracks and improperly sealed joints.
6. When a visible source of the leak has not been identified, wet the system at the anticipated leak area with water and examine the interior area for leaks.
7. Often, an inspection of the underside of the deck will reveal signs of water leakage and/or air infiltration.

## EMERGENCY REPAIRS

GAF must be notified of any leaks within 30 days of discovery of a leak or GAF will have no responsibility for making repairs or replacing that portion of the products that leak as a result of a manufacturing defect. The Building Owner may make temporary repairs to minimize damage to the building or its contents in an emergency. Only qualified workers should perform temporary repairs. These repairs will not result in cancellation of the applicable guarantee or warranty as long as they are reasonable and customary and do not result in permanent damage to the GAF roofing materials. When weather conditions permit, permanent repairs should be completed by an approved GAF contractor at GAF's direction if it is a covered leak or at the building owner's direction for non-covered leaks.

Repairs should not be made with asphalt-based products unless a wet patch type product is needed for emergency purposes. If wet patch products are used they must be completely removed at the time permanent repairs are made.

### Temporary Dry Surface Emergency Repairs

- Clean the coating surface around the damaged area using United Cleaning Concentrate (UCC).
- Rinse the area with clean water and allow it to dry.
- Apply Roof Mate™ Butter Grade and embed Roof Mate™ Fabric as needed to provide additional strength. Contact GAF Technical Support Services before any other product is used to confirm its suitability.

### Specific Repairs to Liquid-Applied Coating Systems over Spray Polyurethane Foam (SPF) Insulation

- Minor breaks in the coating or mechanical damage to sprayed polyurethane foam (SPF) may be repaired with approved urethane caulk and then top-coated with Roof Mate™ Butter Grade and fabric. The damaged foam must be completely cut away prior to repairing. If the repaired area is larger than 2" (51 mm) in diameter, consult GAF Technical Support Services for proper repair procedures. Note: If silicone is used for repair, the area must be filled with Unisil Flashing Grade.
- Large blisters that are not leaking but have broken open should be removed and repaired. If the blister has not broken open, GAF recommends leaving it in place.

## Specific Repairs to Liquid-Applied Coating Systems Not Over Spray Polyurethane Foam (SPF) Insulation

- Repair minor mechanical damage to the liquid-applied coating membrane with specified flashing grade and/or approved urethane caulk, and then top-coat with an approved GAF product. The damaged membrane must be completely cut away prior to repairing. If the repaired area is larger than 2" (51 mm) in diameter, consult GAF Technical Support Services for proper repair procedures.
- If the liquid-applied coating system incorporates reinforcement fabric, then the repair should use specified flashing grade product and fabric.
- For guidelines regarding the use of Unisil applications on acrylic-coated roofs with poor drainage, refer to GAF Technical Advisory Bulletin TAB-C-2018-47.

## ROOF ALTERATIONS

### General

GAF must be notified of any planned roof alterations prior to such alterations being made. Coverage under the guarantee or warranty may be jeopardized if:

- GAF is not notified of alterations.
- The original contractor of record (or another GAF-certified contractor) does not do the required work.
- Non-GAF products are used.

All alterations must be pre-approved, including but not limited to modifications such as roof-top HVAC units or other equipment, pipes, satellite dishes, antennas, conduit, general penetrations, skylights, etc.

**NOTE: These maintenance and inspection procedures are provided for guideline use only. An approved GAF-certified contractor or professional roof consultant may provide a more detailed maintenance program. Maintain records of roof damage and maintenance inspections for each building roof.**

# **SECTION 5**

## Architectural Detail Drawings

## UNITED COATINGS™ ARCHITECTURAL DETAIL DRAWINGS DIRECTORY

Spec Number	Detail Name	Page #
LAR-106A	Seam Flashing – Ribbed Panels	110
LAR-106B	Seam Flashing – Corrugated Panels	110
LAR-106C	Seam Flashing – Standing Seam Panels	111
LAR-106D	Seam Flashing – J Panels	111
LAR-106E	Seam Flashing – Ribbed J-Panels	112
LAR-110	Ridge Cap (Elevated)	112
LAR-202	Metal Roof Edge Fascia Cap	113
LAR-302	Wall Flashing- Over Non Metal Systems	113
LAR-303	General Equipment Curb Flashing	114
LAR-307	Skylight Curb	114
LAR-309	HVAC Curb/Scuttle Hatch Flashing	115
LAR-401	Control Joint - Concrete Deck	115
LAR-502	Pipe Flashing - Over Sprayed Polyurethane Foam	116
LAR-503	Pipe Flashing	116
LAR-510	Fabric Reinforced Drain	117
LAR-512	New Installation Drain Sump Flashing - Over Sprayed Polyurethane Foam	117
LAR-517	Flush Skylight	118

**HORIZONTAL SEAM**

**NOTE:**

1. REFER TO SPECIFIC COATING SYSTEM FOR BASE COAT AND TOP COAT PRODUCTS.
2. FOR SEAM TREATMENT, REFER TO SEAM TREATMENT GUIDE.
3. 12" (305 mm) REQUIRED AT PERIMETER AND TRANSITION SEAM

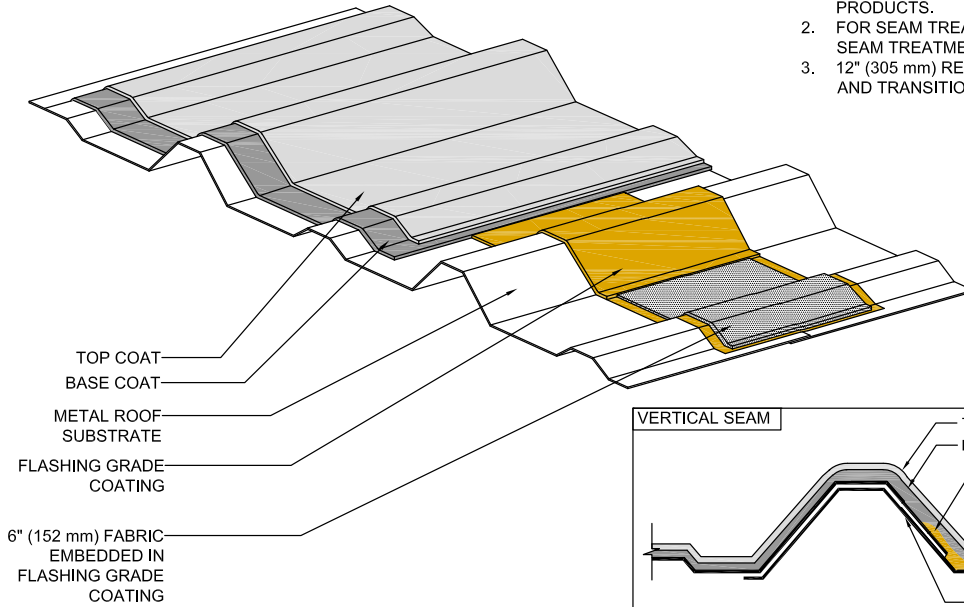

**VERTICAL SEAM**

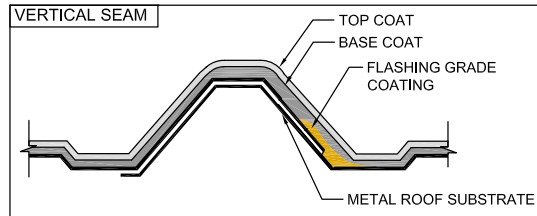

**SEAM FLASHING - RIBBED PANELS**

**106A**

1 Campus Drive,  
Parsippany, NJ  
07054

N.T.S.

LIQUID-APPLIED FLASHING SERIES

Revision Date

6-1-19

**HORIZONTAL SEAM**

**NOTE:**

1. REFER TO SPECIFIC COATING SYSTEM FOR BASE COAT AND TOP COAT PRODUCTS.
2. FOR SEAM TREATMENT, REFER TO SEAM TREATMENT GUIDE.
3. 12" (305 mm) REQUIRED AT PERIMETER AND TRANSITION SEAM

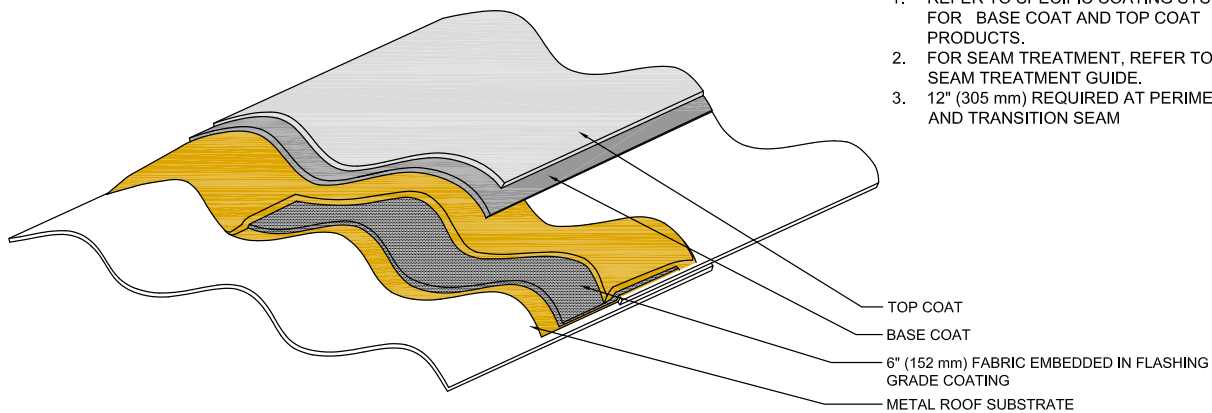

**VERTICAL SEAM**

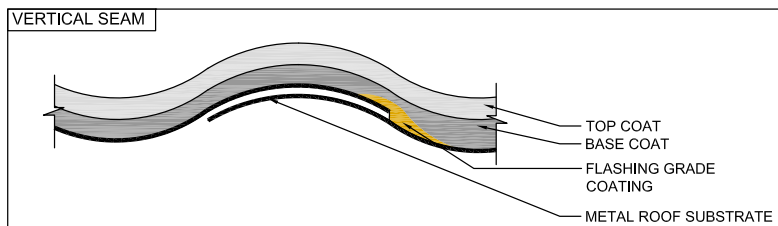

**SEAM FLASHING - CORRUGATED PANELS**

**106B**

1 Campus Drive,  
Parsippany, NJ  
07054

N.T.S.

LIQUID-APPLIED FLASHING SERIES

Revision Date

6-1-19

**HORIZONTAL SEAM**

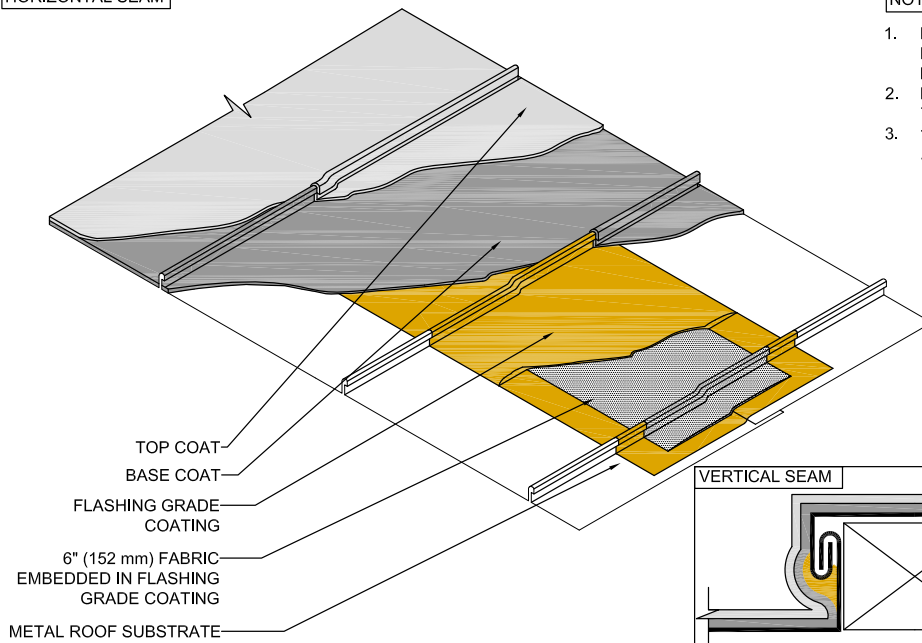

TOP COAT  
 BASE COAT  
 FLASHING GRADE COATING  
 6" (152 mm) FABRIC EMBEDDED IN FLASHING GRADE COATING  
 METAL ROOF SUBSTRATE

**NOTE:**

1. REFER TO SPECIFIC COATING SYSTEM FOR BASE COAT AND TOP COAT PRODUCTS.
2. FOR SEAM TREATMENT, REFER TO SEAM TREATMENT GUIDE.
3. 12" (305 mm) REQUIRED AT PERIMETER AND TRANSITION SEAM

**VERTICAL SEAM**

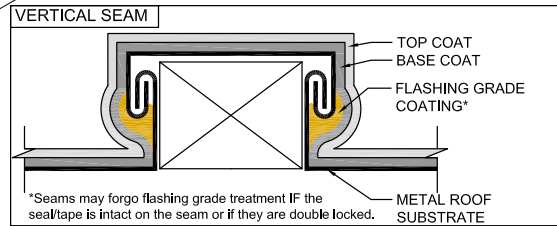

\*Seams may forgo flashing grade treatment IF the seal/tape is intact on the seam or if they are double locked.



1 Campus Drive,  
 Parsippany, NJ  
 07054

**SEAM FLASHING - STANDING SEAM PANELS**

**106C**

Revision Date

N.T.S.

LIQUID-APPLIED FLASHING SERIES

6-1-19

**HORIZONTAL SEAM**

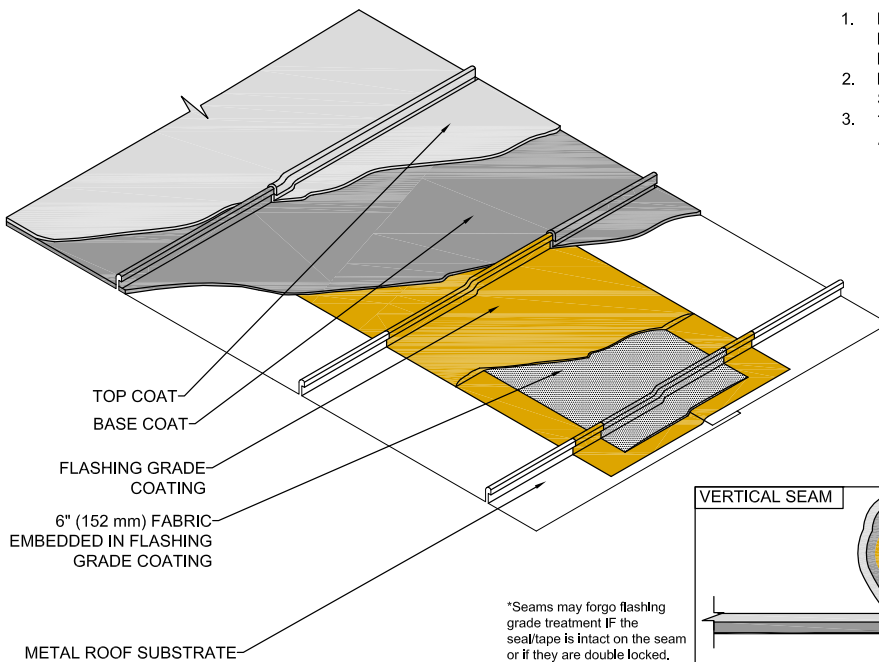

TOP COAT  
 BASE COAT  
 FLASHING GRADE COATING  
 6" (152 mm) FABRIC EMBEDDED IN FLASHING GRADE COATING  
 METAL ROOF SUBSTRATE

**NOTE:**

1. REFER TO SPECIFIC COATING SYSTEM FOR BASE COAT AND TOP COAT PRODUCTS.
2. FOR SEAM TREATMENT, REFER TO SEAM TREATMENT GUIDE.
3. 12" (305 mm) REQUIRED AT PERIMETER AND TRANSITION SEAM

**VERTICAL SEAM**

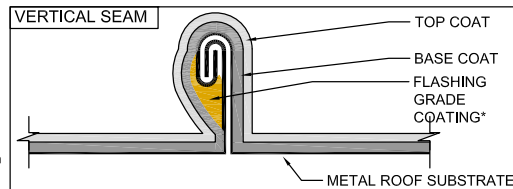

\*Seams may forgo flashing grade treatment IF the seal/tape is intact on the seam or if they are double locked.



1 Campus Drive,  
 Parsippany, NJ  
 07054

**SEAM FLASHING - J PANELS**

**106D**

Revision Date

N.T.S.

LIQUID-APPLIED FLASHING SERIES

6-1-19



**HORIZONTAL SEAM**

**NOTE:**

1. REFER TO SPECIFIC COATING SYSTEM FOR BASE COAT AND TOP COAT PRODUCTS.
2. FOR SEAM TREATMENT, REFER TO SEAM TREATMENT GUIDE.
3. 12" (305 mm) REQUIRED AT PERIMETER AND TRANSITION SEAM.

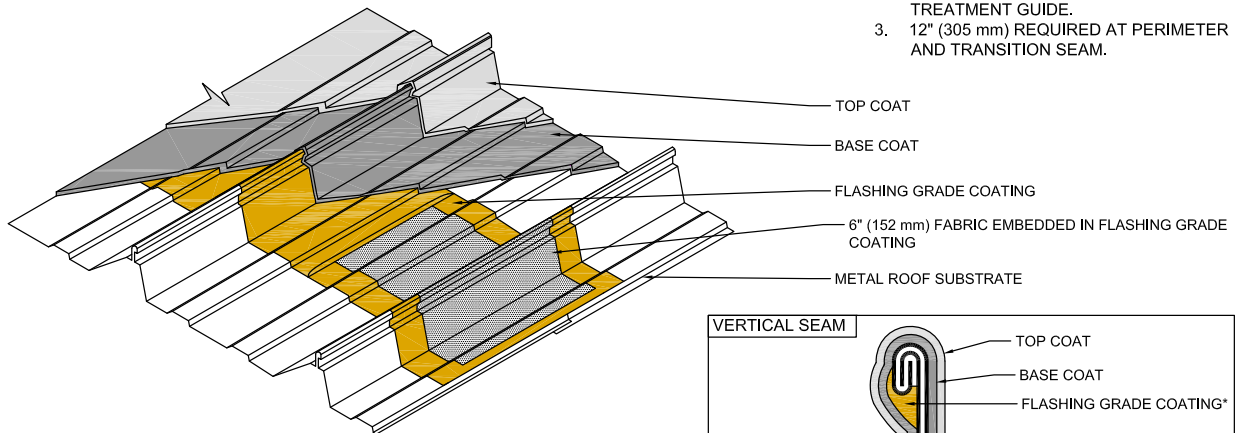

\*Trapezoidal seams may forgo flashing grade treatment with approval via a Field Services pre-job inspection.

**VERTICAL SEAM**

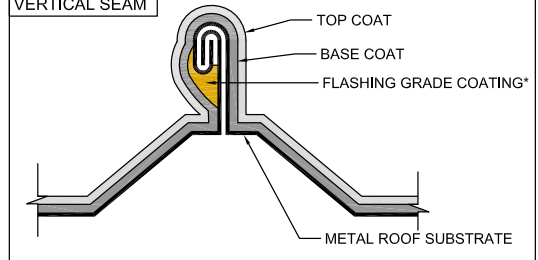

1 Campus Drive,  
Parsippany, NJ  
07054

**SEAM FLASHING - RIBBED J-PANELS**

**106E**

Revision Date

N.T.S.

LIQUID-APPLIED FLASHING SERIES

6-1-19

**NOTE:**

1. REFER TO SPECIFIC COATING SYSTEM FOR BASE COAT AND TOP COAT PRODUCTS.
2. BACKING CAN BE POLYURETHANE FOAM.

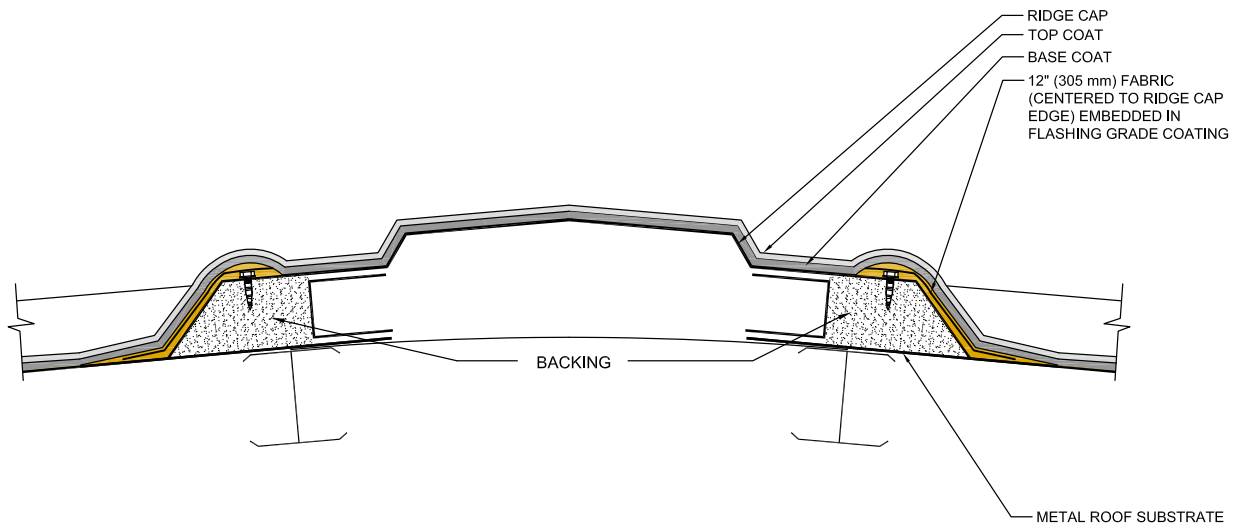

1 Campus Drive,  
Parsippany, NJ  
07054

**RIDGE CAP [ELEVATED]**

**110**

Revision Date

N.T.S.

LIQUID-APPLIED FLASHING SERIES

6-1-19

**NOTE:**

1. REFER TO SPECIFIC COATING SYSTEM FOR BASE COAT AND TOP COAT PRODUCTS

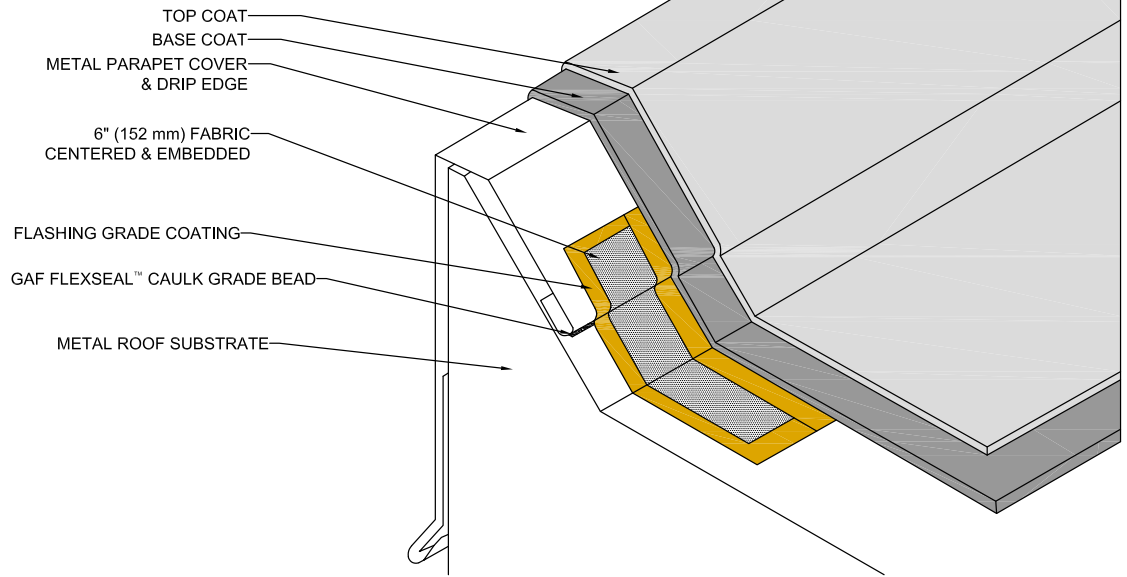

1 Campus Drive,  
Parsippany, NJ  
07054

## METAL ROOF EDGE FASCIA CAP

N.T.S.

LIQUID-APPLIED FLASHING SERIES

# 202

Revision Date

6-1-19

**NOTE:**

1. REFER TO SPECIFIC COATING SYSTEM FOR BASE COAT AND TOP COAT PRODUCTS.
2. REMOVE COUNTERFLASHING PRIOR TO DETAIL APPLICATION.

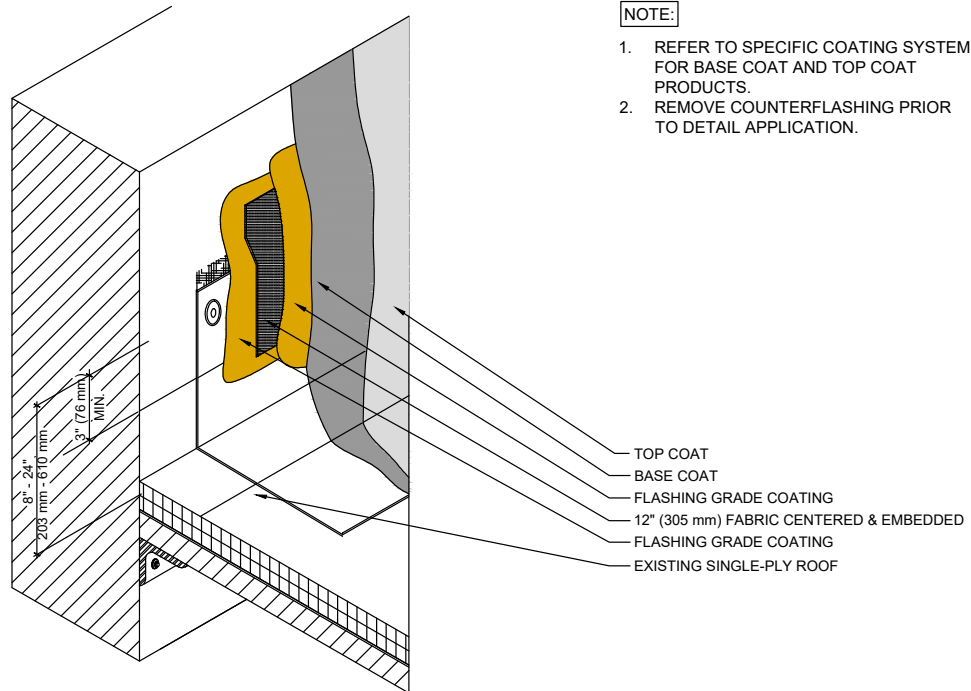

1 Campus Drive,  
Parsippany, NJ  
07054

## WALL FLASHING - OVER NON METAL SYSTEMS

N.T.S.

LIQUID-APPLIED FLASHING SERIES

# 302

Revision Date

1-30-20

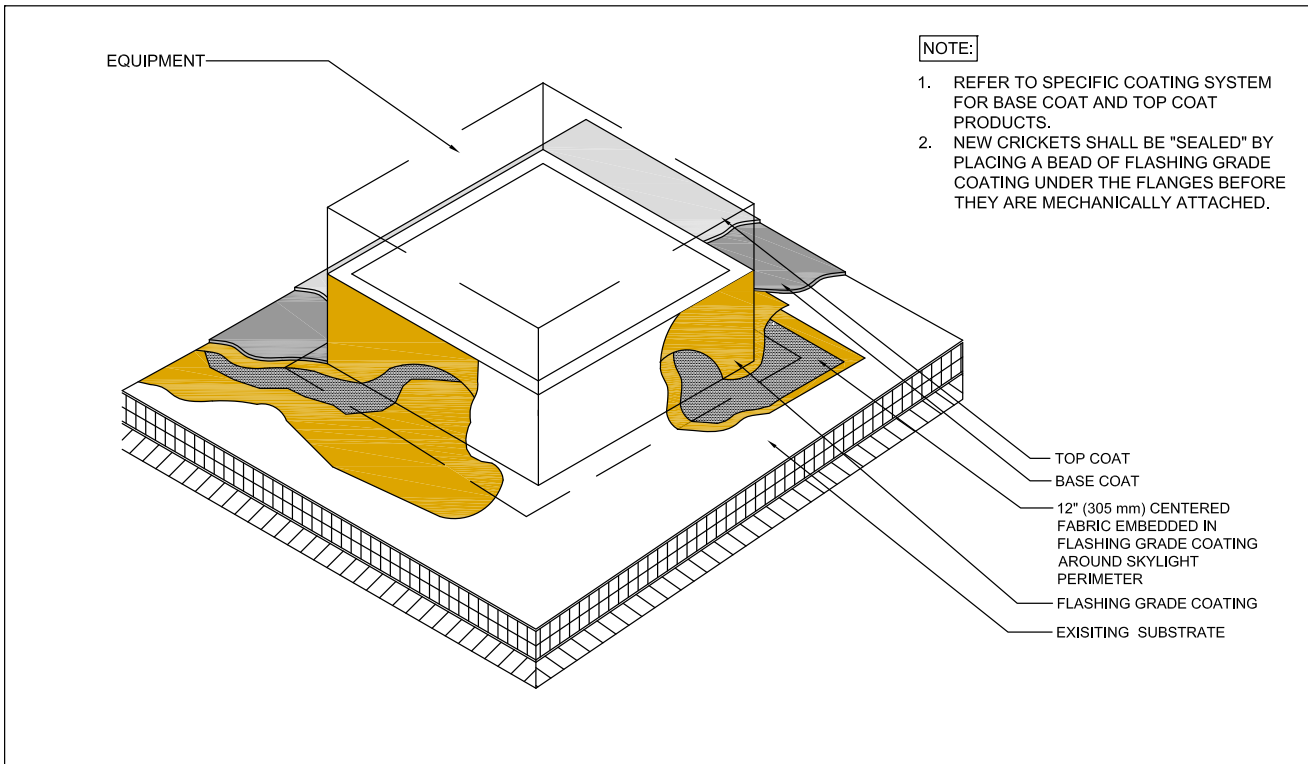

**NOTE:**

1. REFER TO SPECIFIC COATING SYSTEM FOR BASE COAT AND TOP COAT PRODUCTS.
2. NEW CRICKETS SHALL BE "SEALED" BY PLACING A BEAD OF FLASHING GRADE COATING UNDER THE FLANGES BEFORE THEY ARE MECHANICALLY ATTACHED.



1 Campus Drive,  
Parsippany, NJ  
07054

**GENERAL EQUIPMENT CURB FLASHING**

**303**

N.T.S.

LIQUID-APPLIED FLASHING SERIES

6-1-19

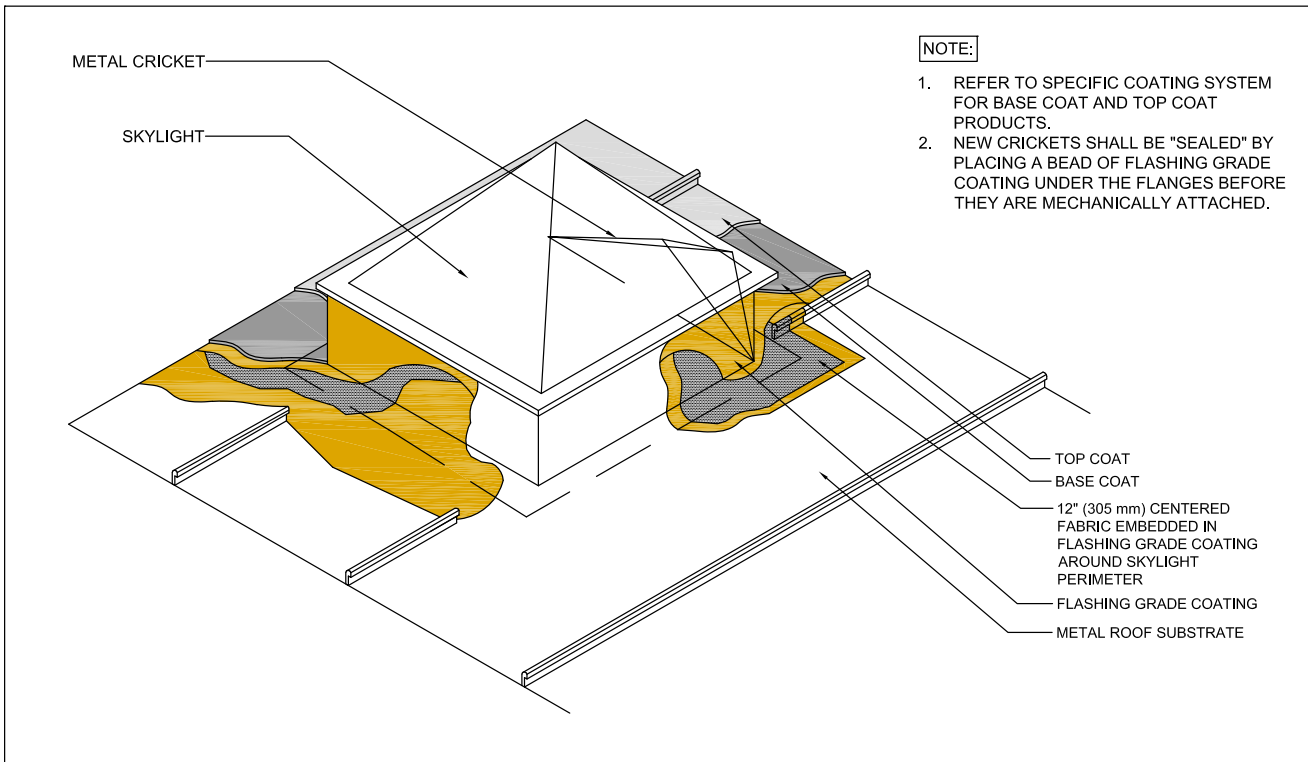

**NOTE:**

1. REFER TO SPECIFIC COATING SYSTEM FOR BASE COAT AND TOP COAT PRODUCTS.
2. NEW CRICKETS SHALL BE "SEALED" BY PLACING A BEAD OF FLASHING GRADE COATING UNDER THE FLANGES BEFORE THEY ARE MECHANICALLY ATTACHED.



1 Campus Drive,  
Parsippany, NJ  
07054

**SKYLIGHT CURB**

**307**

N.T.S.

LIQUID-APPLIED FLASHING SERIES

6-1-19

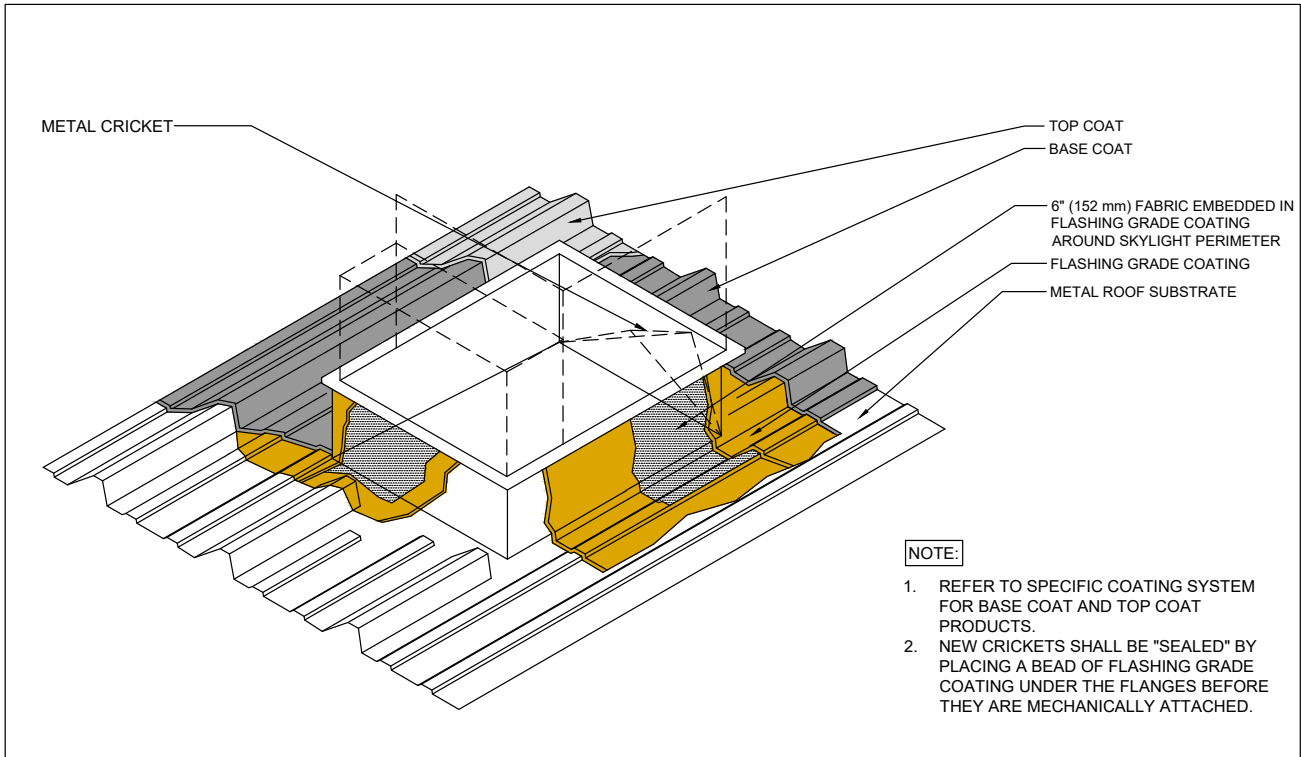

1 Campus Drive,  
Parsippany, NJ  
07054

## HVAC CURB/SCUTTLE HATCH FLASHING

N.T.S.

LIQUID-APPLIED FLASHING SERIES

# 309

Revision Date

1-30-19

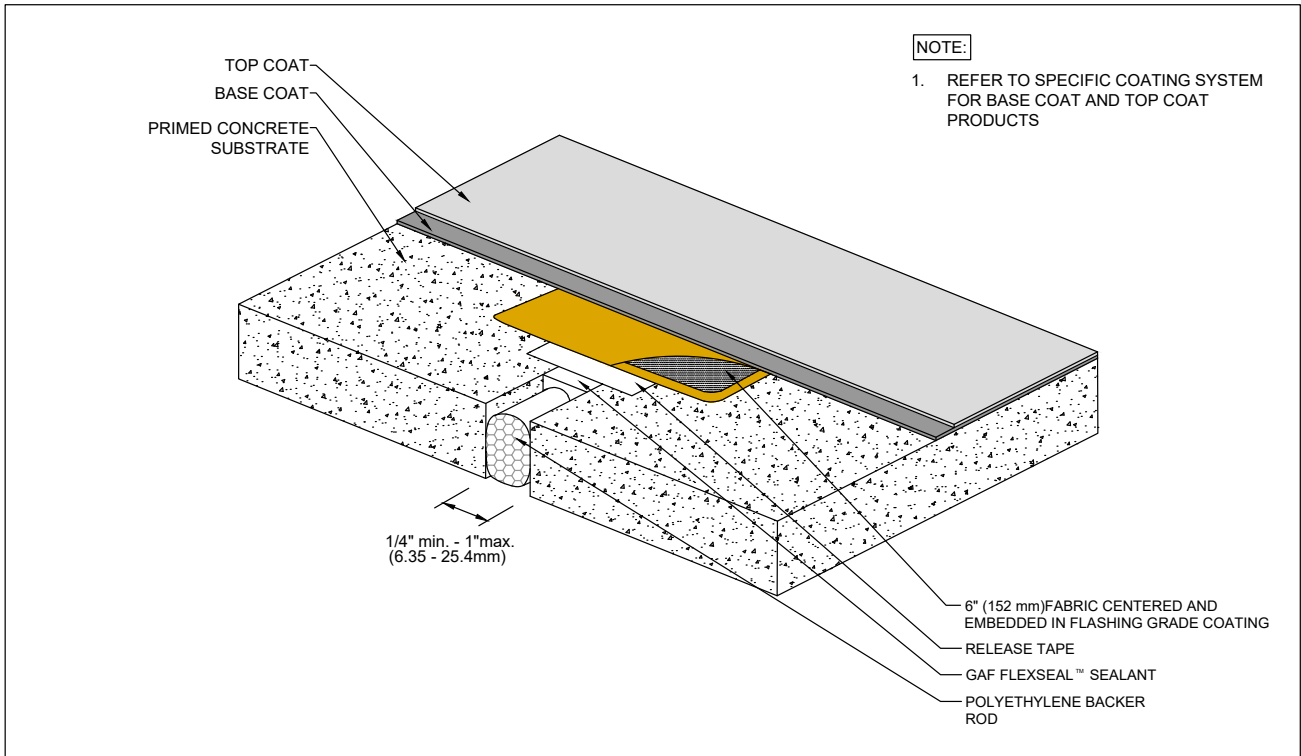

1 Campus Drive,  
Parsippany, NJ  
07054

## CONTROL JOINT - CONCRETE DECK

N.T.S.

LIQUID-APPLIED FLASHING SERIES

# 401

Revision Date

1-30-20

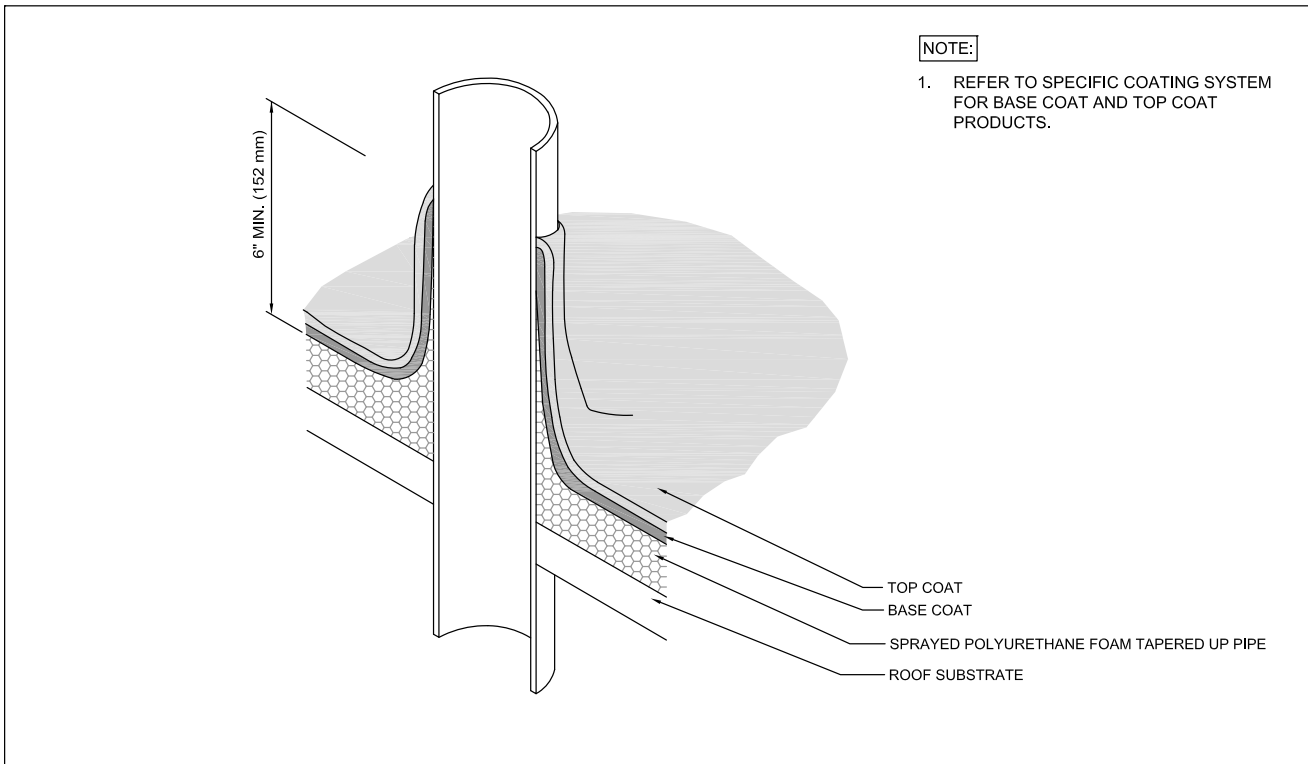

1 Campus Drive,  
Parsippany, NJ  
07054

## PIPE FLASHING - OVER SPRAYED POLYURETHANE FOAM

# 502

Revision Date

N.T.S.

LIQUID-APPLIED FLASHING SERIES

6-1-19

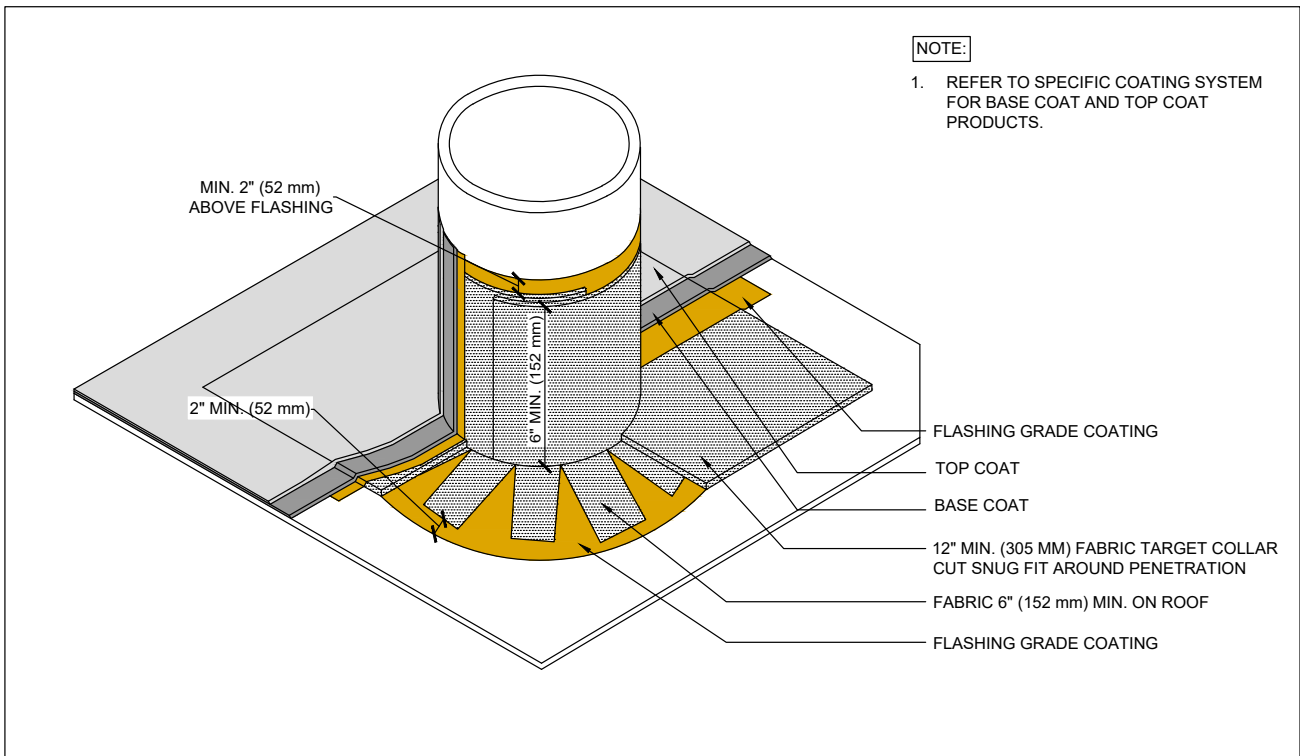

1 Campus Drive,  
Parsippany, NJ  
07054

## PIPE FLASHING

# 503

Revision Date

N.T.S.

LIQUID-APPLIED FLASHING SERIES

1-30-20

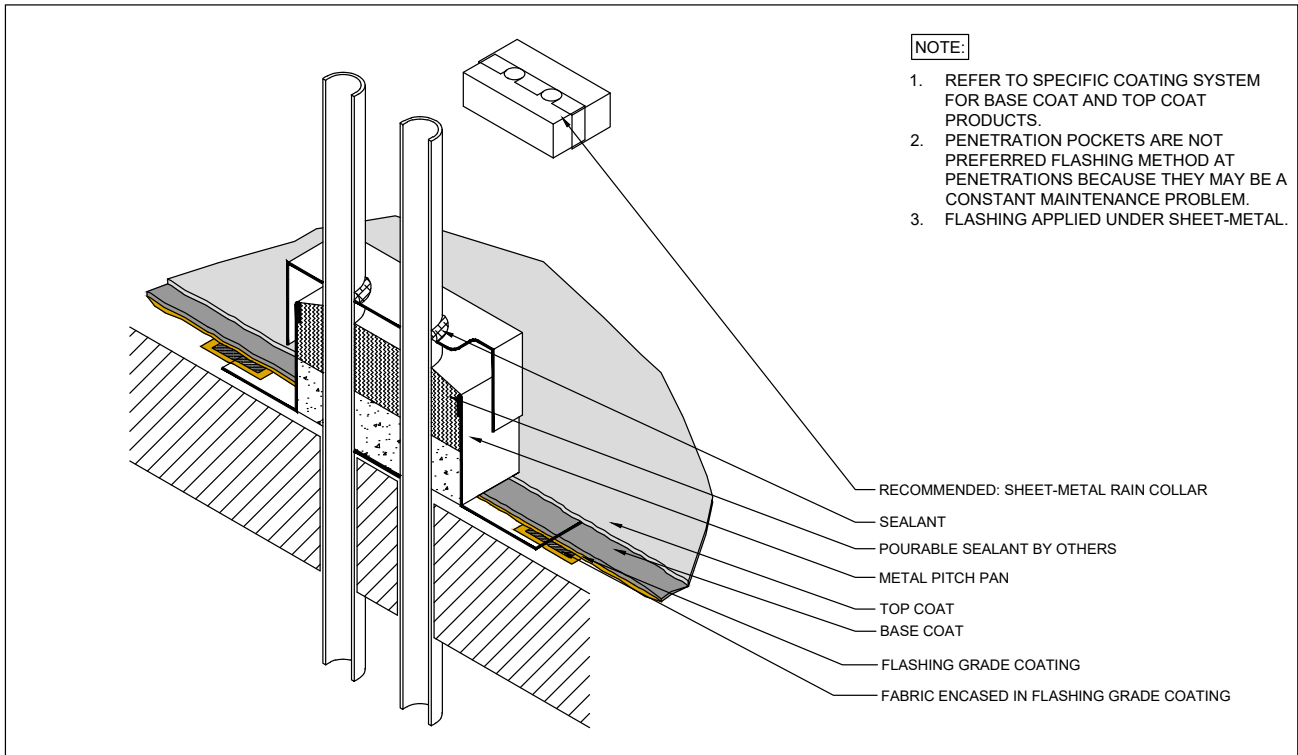

www.gaf.com  
1 Campus Drive,  
Parsippany, NJ  
07054

## PENETRATION POCKET - DOUBLE PENETRATION

LAR-506

N.T.S.

LIQUID-APPLIED FLASHING SERIES

2-26-20

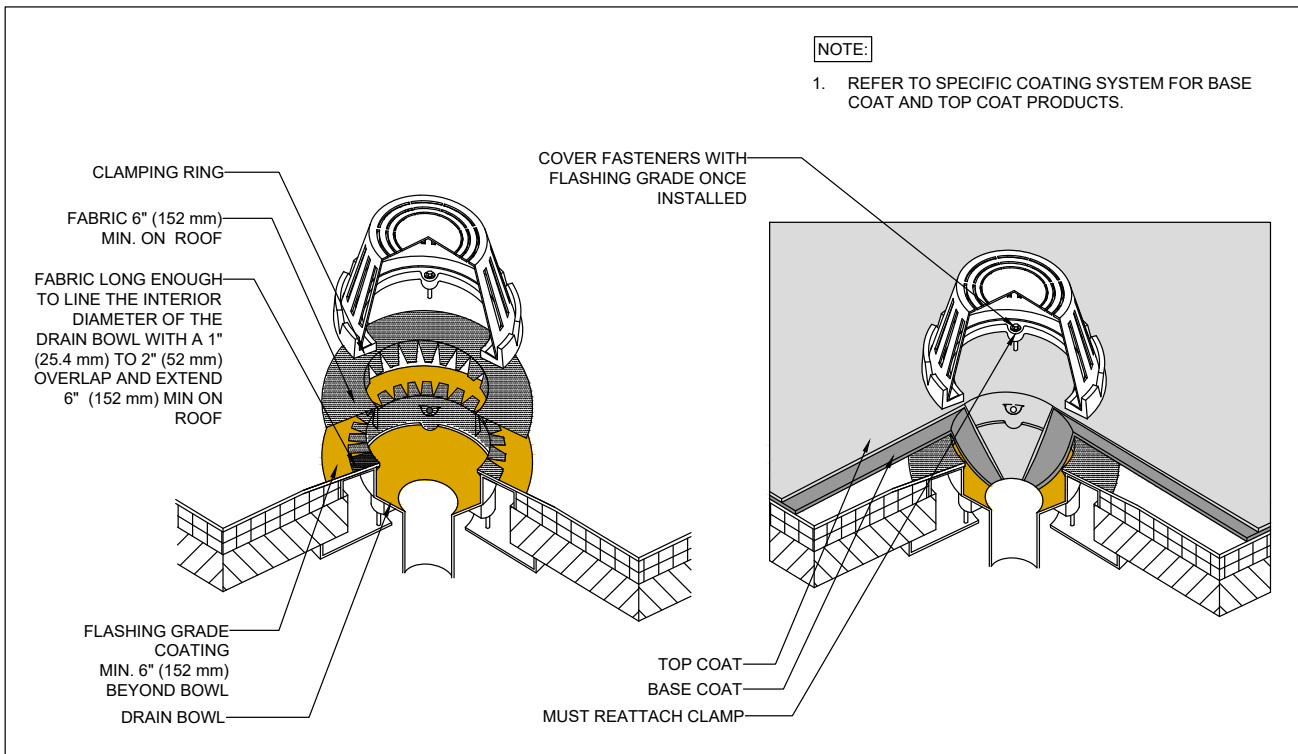

1 Campus Drive,  
Parsippany, NJ  
07054

## FABRIC REINFORCED DRAIN

510

Revision Date

N.T.S.

LIQUID-APPLIED FLASHING SERIES

1-30-20

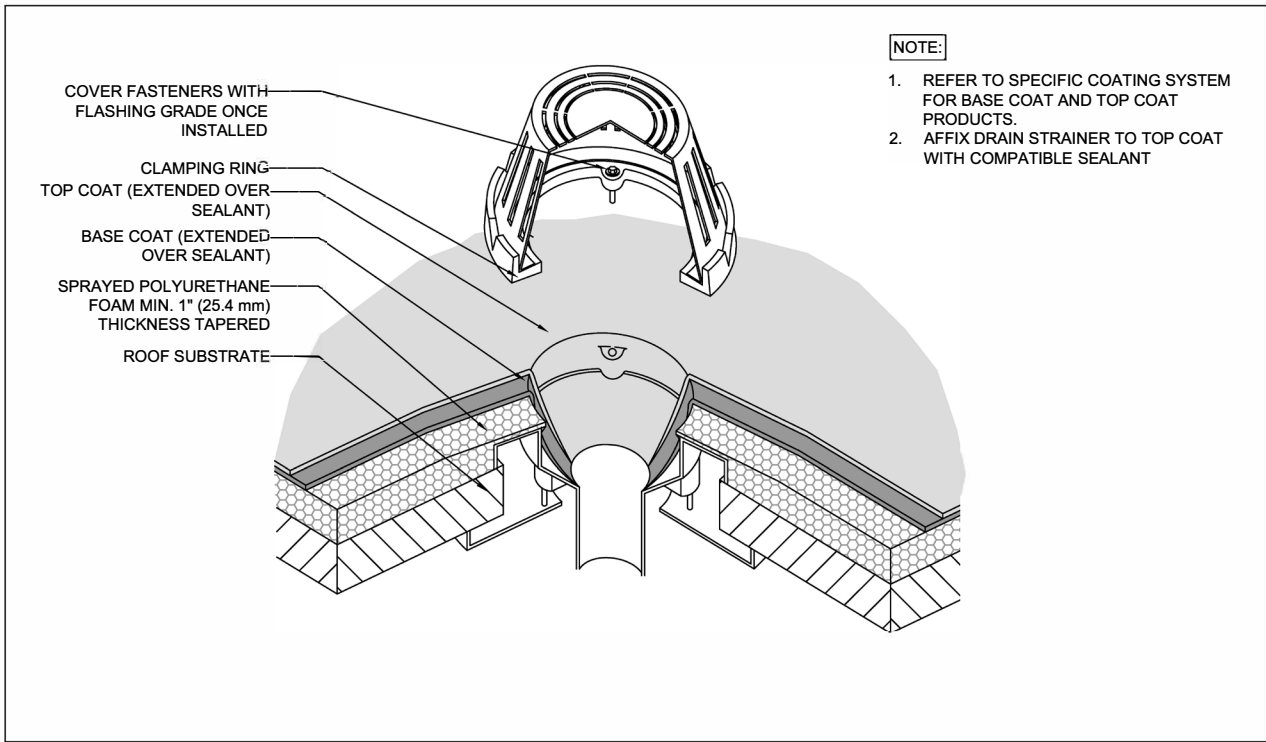

1 Campus Drive,  
Parsippany, NJ  
07054

## NEW INSTALLATION DRAIN SUMP FLASHING - OVER SPRAYED POLYURETHANE FOAM

N.T.S.

LIQUID-APPLIED FLASHING SERIES

# 512

Revision Date

6-1-19

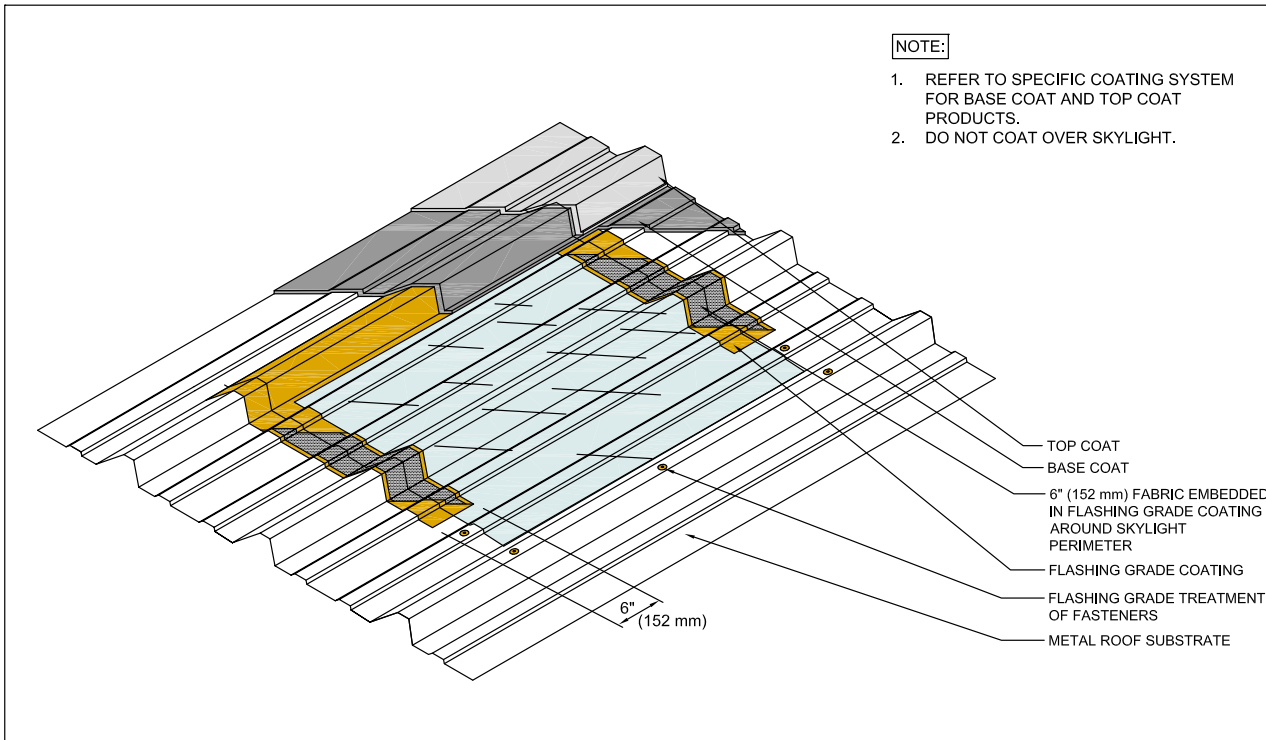

1 Campus Drive,  
Parsippany, NJ  
07054

## FLUSH SKYLIGHT

N.T.S.

LIQUID-APPLIED FLASHING SERIES

# 517

Revision Date

6-1-19



[gaf.com](http://gaf.com)

©2020 GAF 6/20 #878 • COMCO178

