



DEPARTMENT OF REGULATORY AND ECONOMIC RESOURCES (RER)
BOARD AND CODE ADMINISTRATION DIVISION

NOTICE OF ACCEPTANCE (NOA)

MIAMI-DADE COUNTY
PRODUCT CONTROL SECTION

11805 SW 26 Street, Room 208
Miami, Florida 33175-2474
T (786)315-2590 F (786) 315-2599

www.miamidade.gov/economy

GAF
1 Campus Drive
Parsippany, NJ 07054

SCOPE:

This NOA is being issued under the applicable rules and regulations governing the use of construction materials. The documentation submitted has been reviewed and accepted by Miami-Dade County RER -Product Control Section to be used in Miami Dade County and other areas where allowed by the Authority Having Jurisdiction (AHJ).

This NOA shall not be valid after the expiration date stated below. The Miami-Dade County Product Control Section (In Miami Dade County) and/or the AHJ (in areas other than Miami Dade County) reserve the right to have this product or material tested for quality assurance purposes. If this product or material fails to perform in the accepted manner, the manufacturer will incur the expense of such testing and the AHJ may immediately revoke, modify, or suspend the use of such product or material within their jurisdiction. RER reserves the right to revoke this acceptance, if it is determined by Miami-Dade County Product Control Section that this product or material fails to meet the requirements of the applicable building code.

This product is approved as described herein, and has been designed to comply with the Florida Building Code including the High Velocity Hurricane Zone of the Florida Building Code.

DESCRIPTION: GAF Woodland® Shingle

LABELING: Each unit shall bear a permanent label with the manufacturer's name or logo, city, state and following statement: "Miami-Dade County Product Control Approved", unless otherwise noted herein.

RENEWAL of this NOA shall be considered after a renewal application has been filed and there has been no change in the applicable building code negatively affecting the performance of this product.

TERMINATION of this NOA will occur after the expiration date or if there has been a revision or change in the materials, use, and/or manufacture of the product or process. Misuse of this NOA as an endorsement of any product, for sales, advertising or any other purposes shall automatically terminate this NOA. Failure to comply with any section of this NOA shall be cause for termination and removal of NOA.

ADVERTISEMENT: The NOA number preceded by the words Miami-Dade County, Florida, and followed by the expiration date may be displayed in advertising literature. If any portion of the NOA is displayed, then it shall be done in its entirety.

INSPECTION: A copy of this entire NOA shall be provided to the user by the manufacturer or its distributors and shall be available for inspection at the job site at the request of the Building Official.

This NOA renews and revises NOA No. 16-1012.19 consists of pages 1 through 4.
The submitted documentation was reviewed by Alex Tigera.



NOA No.: 22-0310.05
Expiration Date: 04/05/27
Approval Date: 03/31/22
Page 1 of 4

ROOFING ASSEMBLY APPROVAL

Category: Roofing
Sub-Category: Asphalt Shingles
Material: 4-Tab
Deck Type: Wood

SCOPE:

This approves **GAF Woodland® Shingle** as manufactured by GAF as described in this Notice of Acceptance, designed to comply with the Florida Building Code and the High Velocity Hurricane Zone of the Florida Building Code.

PRODUCT DESCRIPTION:

<u>Manufactured by Applicant</u>	<u>Dimensions</u>	<u>Test Specifications</u>	<u>Product Description</u>
GAF Woodland® Shingle	16-5/8" x 40"	TAS 110	Fiberglass reinforced heavy weight asphalt roof shingle, with 4-tabs.

MANUFACTURING LOCATION:

1. Mt. Vernon, IN

EVIDENCE SUBMITTED:

<u>Test Agency</u>	<u>Test Identifier</u>	<u>Test Name/Report</u>	<u>Date</u>
PRI Asphalt Technologies	GAF-321-02-01	TAS 100	10/31/11
	376T0293	ASTM D3462	03/22/22
Underwriters Laboratories, Inc.	11CA48725	ASTM D 3462	12/09/11
	11CA48725	TAS 107	12/09/11
	11CA48725	ASTM E 108	12/09/11
	4788116886	TAS 107	10/11/17

LIMITATIONS:

1. Fire classification is not part of this acceptance; refer to a current Approved Roofing Materials Directory for fire ratings of this product.
2. Shall not be installed on roof mean heights in excess of 33 ft.
3. All products listed herein shall have a quality assurance audit in accordance with the Florida Building Code and Rule 61G20-3 of the Florida Administrative Code.



INSTALLATION:

1. Shingles shall be installed in compliance with Roofing Applications Standard RAS-115.
2. Flashing shall be in accordance with Section 9.3 Option "B" (step-flashings) of Roofing Applications Standard RAS-115.
3. The manufacturer shall provide clearly written application instruction.
4. Exposure and course layout shall be in compliance with Detail "A", attached.
5. Nailing shall be in compliance with Detail "B", attached.

LABELING:

Shingles shall bear the imprint or identifiable marking of the manufacturer's name or logo, city and state of manufacturing facility, and following statement: "Miami-Dade County Product Control Approved" or the Miami-Dade County Product Control Seal as shown below.

**BUILDING PERMIT REQUIREMENTS:**

Application for building permit shall be accompanied by copies of the following:

1. This Notice of Acceptance.
2. Any other documents required by Building Official or Applicable building code in order to properly evaluate the installation of this material.



DETAIL A COURSE LAYOUT

**SHINGLE
INSTALLATION**

Start at either rake and lay in either direction

First Course:

Start with full shingle.
Trim $\frac{1}{2}$ " (3mm) notch.

Second Course:

Trim 5" (127mm) off first shingle

Third Course:

Trim 10" (254mm) off first shingle

Fourth Course:

Trim 15" (381mm) off first shingle

Remaining Courses:

Repeat the 1st - 4th course instructions on the remaining courses, starting the fifth course

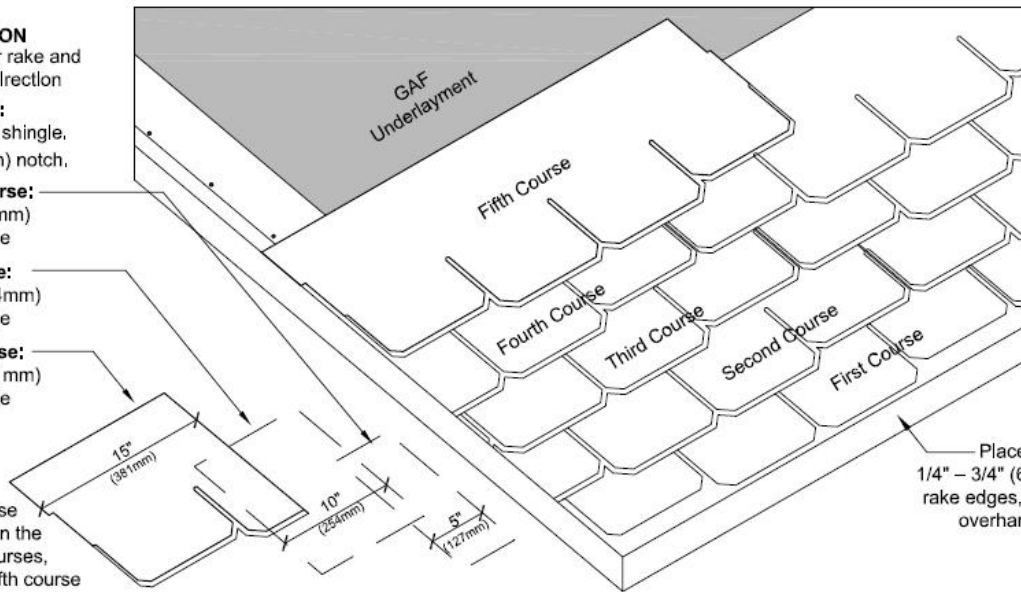

Place first course of shingles $\frac{1}{4}$ " - $\frac{3}{4}$ " (6-19mm) over eave and rake edges, covering starter course overhang, to provide drip edge.

DETAIL B OVERALL DIMENSIONS AND NAILING PATTERN

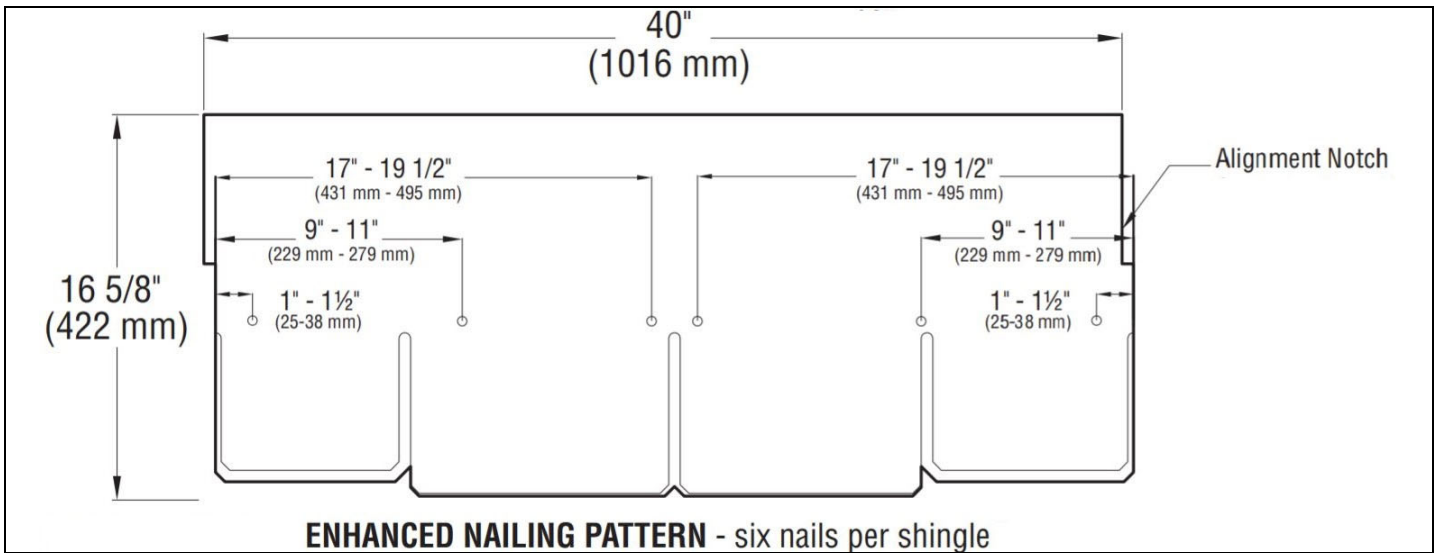

END OF THIS ACCEPTANCE

