

# ADCOR® 500S Waterstop Data Sheet

---

**Conformable, hydro-expansive waterstop for preventing water entry through joints in concrete sub-structures**

## Product Description

GCP Applied Technologies' ("GCP") ADCOR® 500S waterstop is a conformable, butyl rubber-based hydrophilic waterstop strip that expands in contact with water. When fully encapsulated by poured concrete, the expansive forces form a seal against concrete faces. This seal resists hydrostatic pressure, and is specifically engineered to stop water from entering sub-structures. The ADCOR® 500S waterstop is a unique product that has been specifically developed to provide superior performance compared to conventional bentonite and swellable rubber waterstops.

Drawings are for illustration purposes only. For specific application details, refer to [gcpat.com](http://gcpat.com).

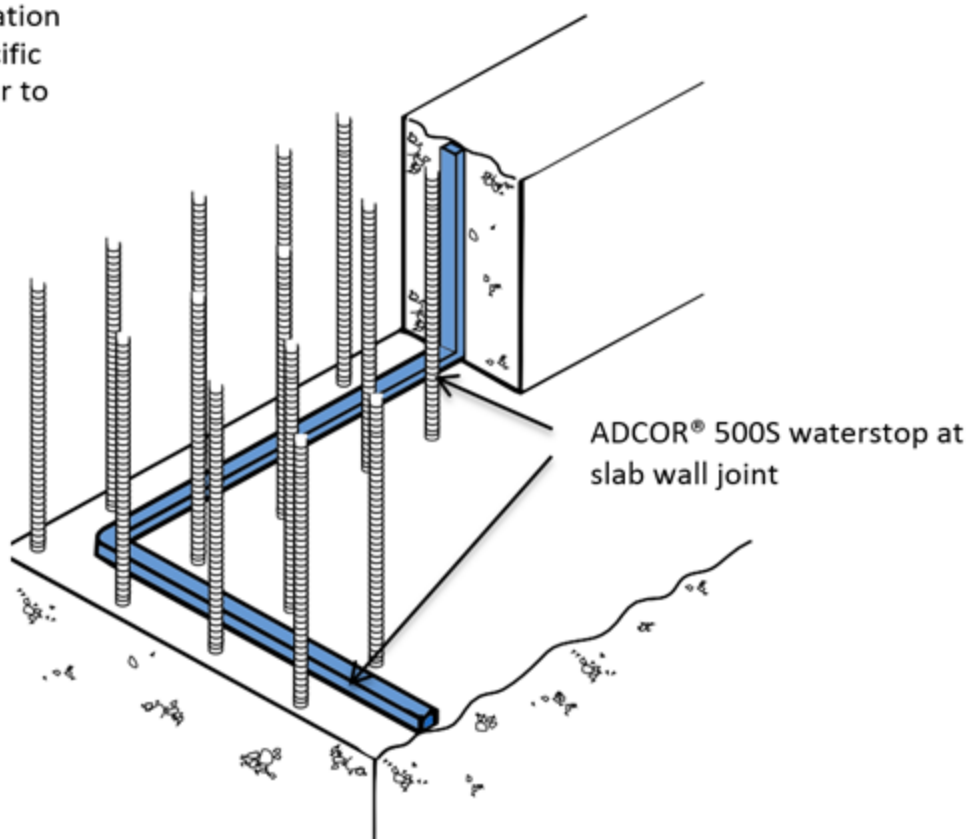

## Applications

- Construction joints in in-situ concrete structures
- Casting new concrete against existing
- Floor slabs cast against diaphragm retaining walls, steel sheet piles and secant piled walls
- Joints between floor slabs and pile caps
- Pipe penetrations through floors and walls

## Product Advantages

- Controlled volumetric expansion reduces risk of concrete spalling
- Retains cohesive strength at both original and expanded volume
- Malleable and conformable, enabling easy application to a variety of concrete profiles and a variety of irregular substrates
- Resists at least 231 ft. (70m) hydrostatic pressure.
- Volumetric expansion min 100%
- Simple overlap jointing onsite.
- Reproducible swell after wet – dry cycling
- Unaffected by freeze/thaw cycling

## System Components

### Waterstop:

- ADCOR® 500S waterstop: a conformable, butyl rubber-based hydrophilic waterstop strip that expands in contact with water

### Ancillary Components:

- ADCOR® 500S adhesive: One-component, caulk-applied adhesive required for attachment of the ADCOR® 500S waterstop

## Limitations of Use

- Approved uses only include those uses specifically detailed in this Product Data Sheet and other current Product Data Sheets that can be found at [gcpat.com](http://gcpat.com).
- ADCOR® 500S waterstop is not intended for any other use. Contact GCP Technical Services where any other use is anticipated or intended.
- To be effective, waterstop networks (including ADCOR® 500S waterstop) must be continuous through all joints and penetrations.
- The ADCOR® 500S waterstop should not be used in movement joints.
- Not suitable for use with pre-cast concrete components.

- Not suitable for use without ADCOR® 500S adhesive. Mechanical fasteners should never be used as the only means of securement.
- Special Note: When this information is printed from the [gcpat.com](http://gcpat.com) global website, a footer appearing on this document will restrict its applicability to the United States. Note that the information and references in this document are hereby expanded and apply to North, Central and South America.

## Safety and Handling

Read and understand the product label and Safety Data Sheet (SDS) for each system component. All users should acquaint themselves with this information prior to working with the products and follow the precautionary statements.

SDSs can be obtained by contacting your local GCP representative or office, by calling GCP toll free at 1-866-333-3SBM (3726) and in some cases from our web site at [gcpat.com](http://gcpat.com).

## Storage

- Store in dry conditions between 40°F (4.5°C)-90°F (32°C).
- Store off ground under tarps or otherwise protected from rain, and all sources of moisture and frost.

## Installation

### Technical Support, Details and Technical Letters

The most up-to-date detail drawings and technical letters are available at [gcpat.com](http://gcpat.com). For complete application instructions, please refer to the current GCP Applied Technologies Contractor Handbook and Literature on [www.gcpat.com](http://www.gcpat.com). Documents in hardcopy as well as information found on websites other than [www.gcpat.com](http://www.gcpat.com) may be out of date or in error. Before using this product, it is important that information be confirmed by accessing [www.gcpat.com](http://www.gcpat.com) and reviewing the most recent product information, including without limitation Product Data Sheets, Contractor Manuals, Technical Bulletins, Detail Drawings and detailing recommendations.

Support is also available by full-time technically trained GCP Applied Technologies field sales representatives and technical service personnel, backed by a central research and development

technical services sta?. For technical assistance with detailing and problem solving, please call toll-free at (866) 333-3SBM (3726).

## Temperature Requirements (application)

- The ADCOR® 500S waterstop can be applied at temperatures between 25°F and 104°F.

## Substrate Preparation

Substrates must be clean and dry, free of all contaminants, such as oil, loose laitance and construction debris prior to the application of the ADCOR® 500S waterstop.

- Concrete surfaces must be sound, and free of large voids and honeycombs.
- Concrete surface must be free from ice, frost and standing water.

## Horizontal and Vertical Installation

1. Apply a continuous minimum 3/8" (10 mm) bead of ADCOR® 500S adhesive directly to the concrete substrate, ensuring the minimum 3" (75mm) of concrete cover will be maintained. ADCOR® 500S adhesive can be applied to damp surfaces but should not be used where the substrate is wet or has standing or flowing water.
2. The ADCOR® 500S waterstop must be installed into the ADCOR® 500S adhesive within 30 minutes of the adhesive application.
3. Remove the release paper from the roll of ADCOR® 500S waterstop before firmly pressing the waterstop into the ADCOR® 500S adhesive. Ensure full and continuous contact between the ADCOR® 500S waterstop and the ADCOR® 500S adhesive and substrate.
4. For all shotcrete applications, mechanical fastening is required to ensure full contact remains between the ADCOR® 500S and the ADCOR® 500S adhesive to the substrate. For certain other conditions, such as overhead applications, very irregular substrates or temperatures below 40°F, mechanical fastening may also be necessary.
5. When fastening is necessary, secure ADCOR® 500S to the ADCOR® 500S adhesive and substrate using masonry nails 1/2 –2 in. (40 mm– 50 mm) long with a washer 3/4 in. (20 mm) in diameter.

Powder actuated fasteners in similar length with a 3/4 in. (20 mm) diameter washers may also be used. Fasteners should be spaced at a maximum of 12 in. (300 mm) on centers or as required to ensure continuous contact with the immediate substrate.

6. All joints should be overlapped side by side at a minimum of 4 in. (100mm). Ensure full contact between jointed pieces of the ADCOR® 500S waterstop.

7. The ADCOR® 500S waterstop can be bent around corners. Ensure that ADCOR® 500S adhesive fills any gaps between the ADCOR® 500S waterstop and the substrate.

8. Any damaged ADCOR® 500S waterstop must be removed and repaired with a new section of ADCOR® 500S waterstop following the above installation procedures

9. Keep the ADCOR® 500S waterstop dry prior to pouring concrete. Any sections showing evidence of premature swelling should be removed and replaced prior to concrete placement.

10. The ADCOR® 500S waterstop must be encapsulated by a minimum of 3 in. (75mm) of concrete cover.

## Supply

PRODUCT	
ADCOR® 500S	3/4 in X 1 in X 16½ ft (5m) rolls 6 rolls/carton 30 cartons/pallet Pallet weight 1720 lbs.
ADCOR® 500S adhesive	13.5 oz. (400ml) sausage for caulking gun application

## ADCOR® 500S Waterstop: Typical Values

PROPERTY	ADCOR® 500S WATERSTOP
Color	Light blue
Weight	0.5 lb/ft
Density	91 lb/ft <sup>3</sup>

Volumetric Expansion in Cement Water	100% min.
Hydrostatic Head Resistance	231 ft (70m)
Service Temperature Range	248°F max.
Application Temperature	25°F (-5°C) – 104°F (40°C)
Minimum Concrete Cover	3in.
Maximum Bend	180° at 32°F (0°C)
Minimum Overlap	4 in (100mm)

**[gcpat.com](http://gcpat.com) | North America Customer Service: 1-866-333-3726**

GCP Applied Technologies Inc., 2325 Lakeview Parkway, Suite 400, Alpharetta, GA 30009, USA

GCP Canada, Inc., 294 Clements Road, West, Ajax, Ontario, Canada L1S 3C6

This document is only current as of the last updated date stated below and is valid only for use in the United States. It is important that you always refer to the currently available information at the URL below to provide the most current product information at the time of use. Additional literature such as Contractor Manuals, Technical Bulletins, Detail Drawings and detailing recommendations and other relevant documents are also available on [www.gcpat.com](http://www.gcpat.com). Information found on other websites must not be relied upon, as they may not be up-to-date or applicable to the conditions in your location and we do not accept any responsibility for their content. If there are any conflicts or if you need more information, please contact GCP Customer Service.

Last Updated: 2026-01-28

[gcpat.com/solutions/products/adcor-hydrophilic-waterstop/adcor-500s-waterstop-data-sheet](http://gcpat.com/solutions/products/adcor-hydrophilic-waterstop/adcor-500s-waterstop-data-sheet)