

ADPRUFE[®] 100

Advanced admixture for integrally waterproof concrete structures to BS 8102:2009 Type B basement construction

Product Description

ADPRUFE[®]100 is an innovative liquid admixture that significantly reduces both the permeability and drying shrinkage of concrete. When used in combination with ADVA[®]superplasticizers, this enhanced concrete performance is achieved by:

- Reduced water absorption and penetration
- A significant reduction in drying shrinkage which produces fewer and thinner cracks
- A low water/cement ratio, which reduces capillary paths in the cured concrete
- High consistence concrete mix for ease of placement
- Enhanced compressive and tensile strengths at all ages.
- When ADPRUFE[®] 100 is used with ADVA[®] high performance concrete admixtures, highly effective integrally waterproof concrete is achieved. ADPRUFE[®] 100 complies with EN 934-2.

System components

- ADPRUFE[®] 100 - liquid waterproof concrete admixture
- ADVA[®] - high range water reducing/superplasticizing admixture.
- Adcor[®] SAS 500S - the ultimate self adhesive hydro expansive waterstop system for construction joints & penetrations
- Serviseal[®] AT - PVC/hydrophilic co-extruded waterstop for designed movement joints
- BETEC[®] 350 - cementitious compound for sealing tie-bar holes.

Applications

- ADPRUFE[®] 100 provides structurally integral waterproofing (Type B construction) as defined in BS 8102:2009 and is suitable for Basement grades 1 to 3
- Water retaining structures
- Swimming pools
- Elevator pits
- Tunnels

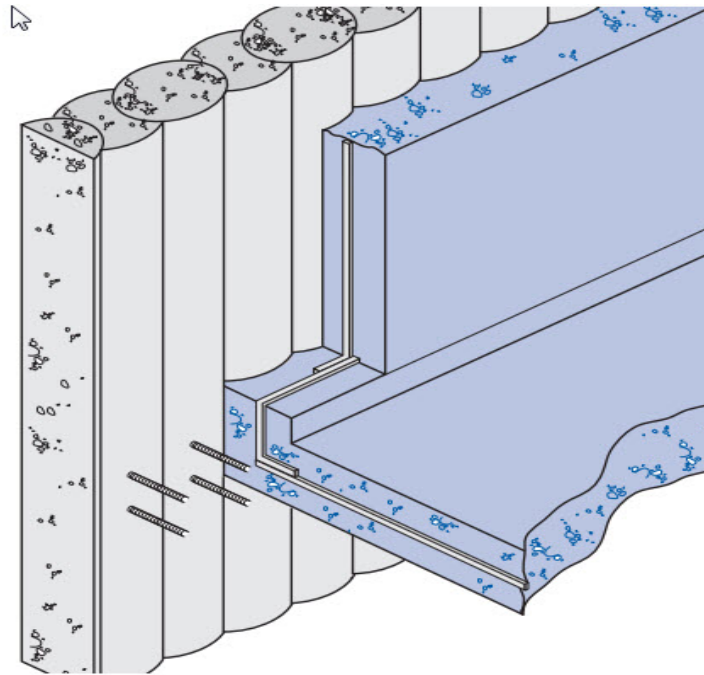

Adprufe 100 integrally waterproof concrete with secant piled retaining wall

Details shown are typical illustrations only and not working drawings. For assistance with working drawings and additional technical advice please contact GCP Technical Services

Product Advantages

- Design Flexibility - Can be combined with GCP membranes or cavity drain systems for enhanced protection in critical applications providing compliance with NHBC Chapter 5.4 combined system requirements from a single source
- Reduces drying shrinkage and permeability of concrete
- Improved consistence resulting in easier, more complete compaction when containing ADVA superplasticiser
- Can be used in all types of concrete, with all types of cementitious binders
- Concentrated, liquid formulation - considerably less than other liquid systems and more easily dispersed than a powder
- No expansive agents
- Improves early strength
- Can be combined with GCP membranes or cavity drain systems for enhanced protection in critical applications

ADPRUFE[®] concrete typical properties

PROPERTY	PLAIN CONCRETE	ADPRUFE [®] 100
ADPRUFE [®] 100 Dosage Rate (Litres/m ³)	Nil	2.5
ADVA [®] Dosage Rate % B.W.C	Nil	0.4 - 1.2%
Typical Cement Content (kg/m ³)	360	360
Effective Water / Cement Ratio	0.5	0.4
Consistence Slump Class	S3	S3

Setting Time (Minutes)	340	390
Air Content (%)	0.9	0.9
Compressive Strength (MPa)	Typical Improvement	
1 day	11	+73%
3 days	26	+65%
7 days	36	+47%
28 days	48	+42%
Water Absorption (%)	2.6	-58%
ISAT- ml/m ² /sec)		
10 minutes	0.246	-62%
30 minutes	0.125	-57%
60 minutes	0.117	-59%
Water Vapor Permeability (gm(Ns) ⁻¹)	6.60E ⁻¹⁰	-56%

Design Criteria

Concrete structures must be designed in accordance with BS EN 1992-1-1, BS EN 1992-1-2, BS EN 1992-3 and BS 8102, or a comparable code. Concrete containing ADPRUFE[®] should be designed in accordance with the requirements of BS EN 1992-1-1 having a maximum crack width of 0.3 mm; water retaining structures should be designed in accordance with BS EN 1992-3 having a maximum crack width of 0.2 mm, when the hydrostatic pressure/ wall thickness is ≤ 5. Additional design guidance for dwellings is given in The Building Regulation Approved Document, Basements for Dwellings.

Note: ADPRUFE[®]100 is not recommended for elevated concrete decks. ADPRUFE[®]100 is not intended or recommended for use in areas where concrete is expected to be exposed to repetitive freeze/thaw cycling, unless the concrete has been air-entrained Consult GCP for further advice.

Admix Properties

- Appearance: Straw coloured clear liquid.
- Air Entrainment: Product does not entrain additional air.
- Chloride Content: Nil.
- Alkali Content: N/A
- Specific Gravity: Approx. 0.912.

Addition Rates

	ADDITON	PER
ADPRUFE [®] 100 for waterproof concrete	2.50 L	m ³

	ADDITON	PER
ADVA® Superplasticizer	400-1200 ml	100 kg of cement

Note: Optimal ADVA® addition rate should be determined by trial mix to ensure specified consistence and maximum water/cement ratio is achieved. Trial mixes should always use specific cements and aggregates that will be used in the concrete. For further advice, consult GCP.

All declared values shown in this data sheet are based on test results determined under laboratory conditions and with the product sample taken directly from stock in its original packing without any alteration or modification of its component parts.

Compatibility with Cements

ADPRUFE®100 can be used with all general purpose cements and combinations including type II additions. For use with special cements we recommend that you consult GCP.

Compatibility with Other Admixtures

As with all concrete admixtures, ADPRUFE®100 should not be pre-mixed with other admixtures or chemicals. The product is engineered to be used with GCP ADVA® superplasticizers, but must be dosed separately. Physical properties of the concrete may be adversely effected if ADPRUFE® is used with other admixtures and chemicals.

Delivery and Storage

ADPRUFE®100 is supplied in 25 and 205 liter non-returnable containers or in 1000 liter transitanks. Store under cover and protect from frost. If the product freezes, contact GCP for advice. Shelf life is 12 months in original, unopened containers. For other system components, refer to separate product data sheets.

Mix Design

ADPRUFE®100 is engineered for use in concrete with medium to high consistence with an effective water/ cement ratio of 0.40 – 0.45. GCP recommend the use of ADVA® superplasticizers (see separate product data sheet).

Where alternative superplasticizers are used, ensure they produce the specified consistence and effective water/cement ratio, at the equivalent cement content. When non GCP superplasticizer is being considered we recommend trial mixes to ensure compatibility. For further advice consult GCP.

Dispensing

It is preferable that ADPRUFE®100 should be introduced into the mixer by means of automatic dispensing equipment.

Concrete Placement

Place concrete in accordance with the recommendations of BS 8000 1990 Section 2.2. Fully compact all concrete using best practices. Do not place concrete when ambient temperatures are 5 °C or less. Refer also to ADPRUFE®

Technical Bulletins for guidance.

Curing

Concrete should be cured in accordance with the recommendations given in BS EN 13670.

Health and Safety

Read the product label and Safety Data Sheets before use. Users must comply with all risk and safety phrases. SDS's can be obtained from GCP Applied Technologies or from our web site at gcpat.com.

gcpat.com | North America Customer Service: 1 877-4AD-MIX1 (1 877-423-6491)

We hope the information here will be helpful. It is based on data and knowledge considered to be true and accurate, and is offered for consideration, investigation and verification by the user, but we do not warrant the results to be obtained. Please read all statements, recommendations, and suggestions in conjunction with our conditions of sale, which apply to all goods supplied by us. No statement, recommendation, or suggestion is intended for any use that would infringe any patent, copyright, or other third party right.

ADCOR, ADPRUFE, ADVA, BETEC and SERVICEAL are trademarks, which may be registered in the United States and/or other countries, of GCP Applied Technologies Inc. This trademark list has been compiled using available published information as of the publication date and may not accurately reflect current trademark ownership or status.

© Copyright 2018 GCP Applied Technologies Inc.

All rights reserved. GCP Applied Technologies Inc., 62 Whittemore Avenue, Cambridge, MA 02140 USA

In the UK, Ipswich Road, Slough, Berkshire, SL1 4EQ.

This document is only current as of the last updated date stated below and is valid only for use in the United States. It is important that you always refer to the currently available information at the URL below to provide the most current product information at the time of use. Additional literature such as Contractor Manuals, Technical Bulletins, Detail Drawings and detailing recommendations and other relevant documents are also available on www.gcpat.com. Information found on other websites must not be relied upon, as they may not be up-to-date or applicable to the conditions in your location and we do not accept any responsibility for their content. If there are any conflicts or if you need more information, please contact GCP Customer Service.

Last Updated: 2022-04-21

gcpat.com/solutions/products/adprufe-100