

GP Georgia-Pacific

**DensGlass®**  
Shaftliner for Area Separation Walls

# TECHNICAL GUIDE

## SHAFTLINER FOR AREA SEPARATION WALLS



**Product Overview**

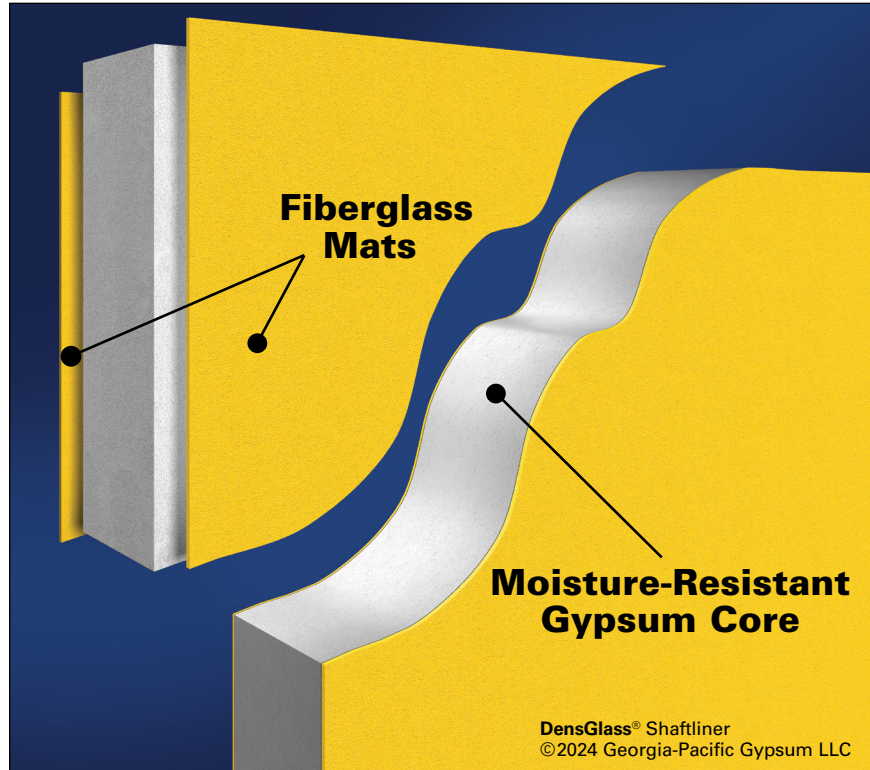

**DensGlass® Shaftliner Area Separation Walls Overview**

DensGlass® Shaftliner is a unique area separation wall panel and a key component of an Area Separation Wall assembly for use in multifamily buildings. In addition, DensGlass® Shaftliner shaftwall/stairwell assemblies save space, go up quickly and don't delay construction during cold weather.

**Mold Resistance**

DensGlass® Shaftliner Panels are mold resistant and have been scored a 10, the highest level of performance for mold resistance, under the ASTM D3273 test method, a testing standard set by ASTM International. In addition, the mold resistance of DensGlass® Shaftliner has been validated by UL Environment and listed in its Sustainable Product Guide utilizing microbial-resistant testing based on ASTM Standard D6329-98. The mold resistance of any building product, when used in actual job site conditions, may not produce the same results as were achieved in the controlled laboratory setting. No material can be considered mold proof. However, when properly used with good design, handling and construction practices, DensGlass® Shaftliner provides increased mold resistance compared to standard paper-faced shaftliner. For additional information, go to [buildgp.com/safetyinfo](http://buildgp.com/safetyinfo).

**Easy to Install**

The area separation wall assembly using DensGlass® Shaftliner is designed for use in multifamily, multistory buildings as a firewall with a total height up to 68 ft. (20,726 mm) (Intertek/WHI fire test) or a total height of up to 44 ft. (13,411 mm) with a UL assembly. Because it is constructed using gypsum board, the assembly is easy to erect and secure, and provides economical fire protection and sound control. DensGlass® Shaftliner conforms to the requirements of the IRC and IBC for use in area separation wall assemblies.

The assembly is constructed at the foundation and continues either to the underside of the roof sheathing or through the roof into the parapet. It is linked to the adjacent framing with aluminum breakaway clips that allow for collapse of the fire-exposed unit without collapse of the solid area separation wall.

**Table of Contents**

*Product Overview* . . . . . 2  
*Sustainability* . . . . . 4  
*Fire Testing and Building Code Compliance* . . . . . 4  
*Installation Instructions* . . . . . 5  
*Special Conditions* . . . . . 6  
*Fire-Rated Assemblies* . . . . . 7  
*Details* . . . . . 8  
*Delivery, Handling and Storage* . . . . . 14  
*Commonly Used Metric Conversions* . . . . . 15

## Product Overview continued

### Fire Resistance

The noncombustible gypsum core of DensGlass® Shaftliner has been reinforced with fiberglass, increasing its strength and fire resistance. DensGlass® Shaftliner has been certified for use in numerous assembly designs investigated by Intertek Testing Services/Warnock Hersey, UL Solutions and Underwriters' Laboratories of Canada (ULC) for hourly fire-resistance ratings. For additional information concerning the use of DensGlass® Shaftliner in fire-rated assemblies, go to page 7 or [buildgpc.com/safetyinfo](http://buildgpc.com/safetyinfo).

### Superior Weather Protection

DensGlass® Shaftliner consists of a water-resistant, noncombustible gypsum core (as defined and tested in accordance with ASTM E136 or CAN/ULC S114) surfaced with coated fiberglass mats that:

- Provides enhanced fire resistance as part of a fire-rated assembly
- Provides superior resistance to the elements
- Resists the growth of mold

### Outstanding Warranty

With its water-resistant gypsum core and coated fiberglass mats, DensGlass® Shaftliner also provides superb protection from the elements and comes with a limited warranty against delamination and deterioration for up to 12 months of exposure to normal weather conditions. For complete warranty details, go to [buildgpc.com/warranties](http://buildgpc.com/warranties).

### Components

The area separation wall is constructed using 1 in. (25.4 mm) thick, 24 in. (610 mm) wide DensGlass® Shaftliner Panels, 25-gauge (18 mils) steel H-studs, 25-gauge (18 mils) steel C-track and 2 in. (51 mm) aluminum breakaway clips. DensGlass® Shaftliner Panels consist of a moisture-resistant core with coated fiberglass mats front and back instead of paper facings like traditional shaftliner panels. DensGlass® Shaftliner Panels are backed by a limited warranty against delamination and deterioration for up to 12 months of exposure to normal weather conditions and a limited warranty against manufacturing defects for five years from date of purchase. For additional warranty details, go to [buildgpc.com/warranties](http://buildgpc.com/warranties).

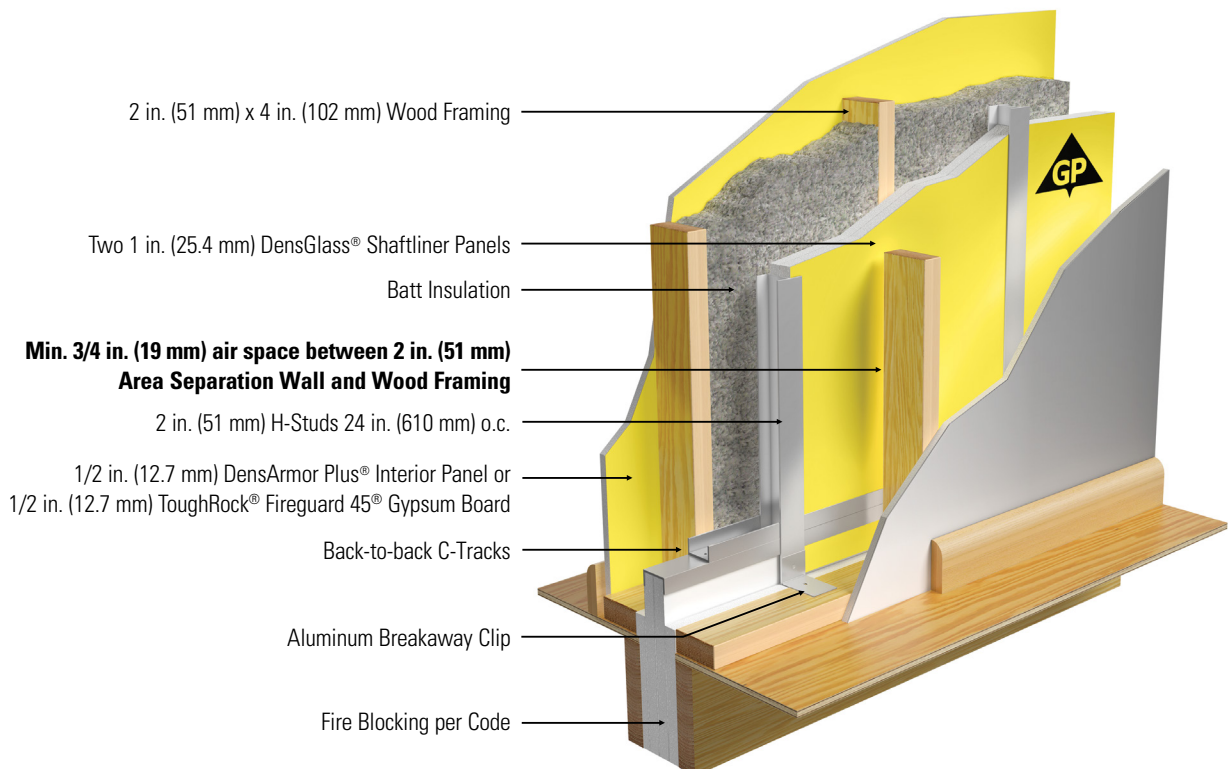

## Sustainability

Georgia-Pacific Gypsum's definition of sustainability is meeting the needs of society today without jeopardizing our ability to do so in the future. We are committed to using resources efficiently to provide innovative products and solutions that meet the needs of customers and society, while operating in a manner that is environmentally and socially responsible, and economically sound.

We continue to focus on:

- Improving energy efficiency at our manufacturing plants
- Seeking out opportunities to reduce water use, and to reuse water more efficiently
- Seeking new ways to reduce and improve air emissions
- Ensuring responsible resource management through material recovery and source-reduction innovation

Green building codes, standards and programs are establishing themselves across the country. They promote the use of products that contribute to the performance of the building, along with minimizing environmental and human health impacts over the life of the building or home. Because we embrace product performance and operate in an environmentally, socially and economically sound manner, owners and architects can feel good about the structures they build using our products.

Many of our products contribute to LEED® and other green building programs. Please refer to the LEED® Request link at [buildgp.com](http://buildgp.com) to get recycled content, low-emitting material and regional material information for your project. For general sustainability information, visit [buildgp.com/sustainability](http://buildgp.com/sustainability).

## Fire Testing and Building Code Compliance

The area separation wall has been fire tested to ASTM E 119 and CAN/ULC S-101. The two-hour fire-rated area separation wall assembly using DensGlass® Shaftliner Panels is listed by UL, ULC and ITS/WHI, and meets the requirements of the International Building Code (IBC) Section 706, Fire Walls. The area separation wall assembly using DensGlass® Shaftliner Panels is listed in the UL Fire Resistance Directory under UL Design U373 or U375, the ULC Fire Resistance Directory ULC Design No. W312 and the Warnock Hersey Listed Product and Code Compliance Directory under WHI GP/WA 120-04. Consult the applicable fire resistance directory for additional information.

## Installation Instructions

The Area Separation Wall is constructed once the framing for one townhouse unit is complete and prior to the construction of the adjacent unit. The solid 2 in. (51 mm) Area Separation Wall is constructed a minimum 3/4 in. (19 mm) away from the adjacent framing, which is typically constructed from wood. In many cases, the Area Separation Wall is positioned 1 in. (25.4 mm) away from the wall framing to accommodate the 1 in. (25.4 mm) DensGlass® Shaftliner Panels used as fireblocking between the floor levels. The UL Design U373 and U375 Area Separation Wall assemblies were evaluated at a height up to 44 ft. (13,411 mm) and the ITS/WHI GP/WA 120-04 Area Separation Wall assemblies were evaluated at a height up to 68 ft. (20,726 mm).

### Erecting the 2 in. (51 mm) Area Separation Wall

1. Position 2 in. (51 mm) C-Track a minimum 3/4 in. (19 mm) from the framed wall of the adjacent unit. Fasten C-Track to foundation with fasteners spaced a maximum of 24 in. (610 mm) o.c. When specified, apply a minimum 1/4 in. (6 mm) bead of acoustical sealant under the C-Track for acoustical privacy. Run the C-Track to the end of the foundation. In case of offset units, see 15 under Special Conditions.
2. Start the wall with a vertical C-Track at one end. Install two 1 in. (25.4 mm) shaftliner panels vertically with either side facing out\* into the C-Track at one end of the area separation wall. Install the H-stud into the C-track and over the double beveled edges of the shaftliner panels and continue alternately until the wall has reached the opposite end of the foundation. Terminate the wall using a C-Track. The vertical C-Tracks at each end of the wall should be attached in the corners to the horizontal sections of the C-Track using a minimum of one 3/8 in. (9 mm) minimum length pan head screw. Vertical C-Tracks at end of walls should be attached to wall sheathing.

*Note: Some authorities may require labeling to be visible.*

3. Cap the first section or row of the Area Separation Wall with a C-Track and attach to the vertical C-Track in the corners using a minimum of one 3/8 in. (9 mm) minimum length pan head screw.
4. Breakaway clips span the minimum 3/4 in. (19 mm) air space and provide a fusible link between the H-studs and the adjacent wall framing. Attach the breakaway clips to the flange of the H-stud using a minimum of one 3/8 in. (9 mm) minimum length pan head screw and to the adjacent wood framing using a minimum of one 1 in. (25.4 mm) minimum length drywall screw.

UL DESIGNS U373 & U375			ITS/WHI GP/WA 120-04		
	Wall Height >23 ft.	Wall Height >23 ft.		Wall Height >20 ft.	Wall Height >20 ft.
Breakaway Clip Vertical Spacing	10 ft. o.c.	5 ft. o.c for < 23 ft. and 10 ft. o.c > 23 ft.	Breakaway Clip Vertical Spacing	10 ft. o.c.	8 ft. for < 20 ft. and 10 ft. for > 20 ft. 44 ft. max
Breakaway Clip Horizontal Spacing	24 in. o.c.	24 in. o.c.	Breakaway Clip Horizontal Spacing	48 in. o.c.	48 in. o.c.

5. Fireblocking is installed on both sides of the Area Separation Wall at each floor level as defined in the IBC (see Details section). For approved fire-blocking materials, see Special Conditions, Item 8.
6. To continue the wall, install a C-Track over the C-Track used to cap the lower section, placed back to back and attached together with two 3/8 in. (9 mm) pan head screws at ends and spaced 24 in. (610 mm) o.c. Stagger back-to-back C-Track joints a minimum of 12 in. (305 mm).
7. If a parapet is not specified, see Special Conditions, Item 11, for two methods for installing a gypsum board roof underlayment. Consult with local code authority for proper method.
8. Once the 2 in. (51 mm) Area Separation Wall is erected, construction of the adjacent interior wall framing can begin. Breakaway clip and fire-blocking installation is identical for both sides of the 2 in. (51 mm) Area Separation Wall.
9. Do not install insulation in the system until the building has been properly closed in.

**Note: Consult the fire resistance directory or test report for complete assembly information. For additional fire safety information concerning DensGlass® Shaftliner, visit [buildgp.com/safetyinfo](http://buildgp.com/safetyinfo).**

**Aluminum Angle or Breakaway Clip**

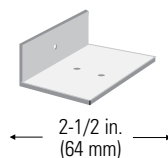

**C-Track, Cap, Edge or End Closure**

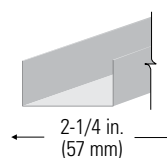

**H-Stud, 25-Gauge (18 mils)**

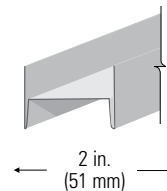

**CAUTION: For product fire, safety and use information, go to [buildgp.com/safetyinfo](http://buildgp.com/safetyinfo).**

For latest information and updates: **5**  
**Technical Service Hotline 1.800.225.6119 or [buildgp.com](http://buildgp.com)**

## Special Conditions

1. When an H-Stud does not align with the adjacent wood framing, fasten blocking to wood framing members and attach breakaway clip to blocking using one 1-1/4 in. (32 mm) drywall screw and to the H-Stud using a minimum of one 3/8 in. (9 mm) minimum length pan head screw.
2. If gaps are present between back-to-back C-Tracks, fill gap using approved fire caulking material.
3. When wall framing is spaced greater than 1 in. (25.4 mm) away from the solid 2 in. (51 mm) Area Separation Wall, aluminum clips with longer legs are permitted. Contact clip manufacturers for modified clips. Additional wood blocking can be added between the wood studs to provide clip support. Space wood blocking a minimum 3/4 in. (19 mm) away from the Area Separation Wall's 1 in. gypsum panels.
4. The solid 2 in. (51 mm) Area Separation Wall is non-load bearing. The adjacent framed wall can be designed as load bearing.
5. The wall located adjacent to the solid 2 in. (51 mm) Area Separation Wall, a minimum of 3/4 in. (19 mm) away, can be constructed of wood or steel framing. When constructed using steel framing, use a minimum of one 3/8 in. (9 mm) minimum length pan head screw to attach the aluminum breakaway clip.
6. The support walls located adjacent to, and on each side of, the solid 2 in. (51 mm) Area Separation Wall protect and maintain the required 3/4 in. (19 mm) air space, offer increased acoustical privacy and provide necessary aesthetics. These walls can be designed as load bearing and readily accommodate electrical and plumbing systems. These systems should not impede the required 3/4 in. (19 mm) air space. Apply acoustical sealant around penetrations for maximum acoustical privacy.
7. The required 3/4 in. (19 mm) air space can be eliminated if the metal framing is covered on both faces with 6 in. (152 mm) wide, 1/2 in. (12.7 mm) DensArmor Plus® Fireguard C® Interior Panels or 1/2 in. (12.7 mm) ToughRock® Fireguard C® Gypsum Boards or 5/8 in. (15.9 mm) ToughRock® Fireguard X® Gypsum Boards or 5/8 in. (15.9 mm) DensArmor Plus® Fireguard® Gypsum Board Strips. The gypsum board strips are attached with 1 in. (25.4 mm) drywall screws spaced 12 in. (305 mm) o.c. to the metal framing. This primarily occurs in accessible attic areas. Inaccessible attic areas do not require the 6 in. (152 mm) wide gypsum board strips.
8. The required fireblocking between floor levels may consist of 2 in. (51 mm) nominal lumber, or two thicknesses of 1 in. (25.4 mm) nominal lumber with broken lap joints, or one thickness of 0.719 in. (18.3 mm) wood structural panel with joints backed by 0.719 in. (18.3 mm) wood structural panel, or one thickness of 0.75 in. (19 mm) particleboard with joints backed by 0.75 in. (19 mm) particleboard. Gypsum board, including 1 in. (25.4 mm) DensGlass® Shaftliner and 5/8 in. (15.9 mm) DensArmor Plus® Fireguard® Interior Panel, batts or blankets of mineral wool or fiberglass or other approved materials installed in such a manner as to be securely retained in place shall be permitted as an acceptable fireblock (per Chapter 7 of the IBC).
9. The Area Separation Wall assembly can be constructed with or without a parapet.
10. At the intersection of the solid 2 in. (51 mm) Area Separation Wall and the underside of the structural roof sheathing, cut liner panels at an angle to provide a tight fit to the structural sheathing. The 2 in. (51 mm) Area Separation Wall is not required to be capped using a C-Stud. Where the shaftliner panels are not tight to the structural sheathing, apply an approved fireblocking material (see Special Conditions, Item #8) to both sides of the Area Separation Wall.
11. There are two methods for installing a fire-resistant roof underlayment: the ledger strip method and the partial roof underlayment method. Consult with local code authority for proper method. In the ledger strip method, one layer of 5/8 in. (15.9 mm) DensArmor Plus® Fireguard® Interior Panel or 5/8 in. (15.9 mm) ToughRock® Fireguard X® Gypsum Board is placed 4 ft. (1219 mm) on both sides of the Area Separation Wall. The gypsum board is cut to fit tightly between the roof framing members. Nominal 2 in. (51 mm) x 2 in. (51 mm) wood ledger strips hold the gypsum board snug to the underside of the roof sheathing and flush with the top of the roof framing. The ledgers are attached to the roof framing and form a continuous strip. The second method is using fire-treated plywood at least 4 ft. (1219 mm) on both sides of the Area Separation Wall.
12. Penetrations through the solid 2 in. (51 mm) Area Separation Wall should be protected in accordance with Chapter 7 of the IBC. For specific installation details, consult UL category XHEZ Through-penetration Firestop Systems.
13. Size and protection of openings in the solid 2 in. (51 mm) Area Separation Wall shall be in accordance with the IBC, Section 706. When the Area Separation Wall is designed as a Party Wall ("any wall located on a property line between adjacent buildings, which is used or adapted for joint service between the two buildings," as listed in the IBC, Section 706), openings are not permitted.
14. For specialized end-use areas, such as bathrooms, the adjacent framed walls can be covered with DensShield® Tile Backer from Georgia-Pacific in lieu of standard paper-faced gypsum board or fiberglass mat-faced interior panels.
15. An offset occurs when one unit extends past the front or back edge of an adjacent unit. The H-studs of the Area Separation Wall are not designed for hanging sheathing and cladding, so planning is required before construction begins. There are two ways to deal with the offset. The first option is to pour enough concrete so that the Area Separation Wall and adjacent framed wall can extend to the farthest point. Sheathing and cladding can then be installed to the adjacent framed wall. The second option is to terminate the Area Separation Wall at the end of the shared wall and then construct a one-hour wall to the end of the offset unit. Both scenarios are shown in the Details section of this brochure.
16. Provide for deflection of live loaded floor assemblies by using relief joints or floating trim.

## Special Conditions continued

17. For specialized end-use areas, such as bathrooms, the adjacent framed walls can be covered with DensShield® Tile Backer from Georgia-Pacific in lieu of standard paper-faced gypsum board or fiberglass mat-faced interior panels.
18. An offset occurs when one unit extends past the front or back edge of an adjacent unit. The H-studs of the Area Separation Wall are not designed for hanging sheathing and cladding, so planning is required before construction begins. There are two ways to deal with the offset. The first option is to pour enough concrete so that the Area Separation Wall and adjacent framed wall can extend to the furthest most point. Sheathing and cladding can then be installed to the adjacent framed wall. The second option is to terminate the Area Separation Wall at the end of the shared wall and then construct a one-hour wall to the end of the offset unit. Both scenarios are shown in the Details section of this brochure.
19. Provide for deflection of live loaded floor assemblies by using relief joints or floating trim

## Fire-Rated Assemblies

DensGlass® Shaftliner is UL and ULC certified as **Type DGUSL** and included in numerous assembly designs investigated by UL and ULC for hourly fire resistance ratings.

In addition, DensGlass® Shaftliner is certified as “Type X” in accordance with ASTM C 1658. “Type X” as used in this technical guide designates gypsum board manufactured and tested in accordance with specific ASTM standards for increased fire resistance beyond regular gypsum board. Please consult the ASTM standard for the specific product (for example, ASTM C 1658 for glass mat interior panels) for further information and significance of use.

**The following design assemblies are for illustrative purposes only. Consult the fire resistance directory or test report for complete assembly information. For additional fire safety information concerning DensGlass® Shaftliner, visit [buildgp.com/safetyinfo](http://buildgp.com/safetyinfo).**

## System Assemblies – Two-Hour Ratings – Area Separation Walls

### Two-Hour Fire Rating

Design Reference: UL U373, UL U375, ULC W312, WHI GP/WA 120-03, cUL U373, cUL U375

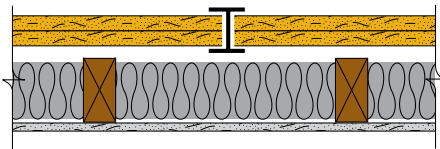

### 55-59 STC Sound Transmission

Test Reference: RAL TL 10-290

Two layers 1 in. (25.4 mm) DensGlass® Shaftliner inserted in H-Studs 24 in. (610 mm) o.c. Min. 3/4 in. (19 mm) air space between liner panels and adjacent wood or metal framing.

Sound Tested with 2 in. (51 mm) x 4 in. (102 mm) stud wall with 1/2 in. (12.7 mm) ToughRock® Gypsum Board and 3-1/2 in. (89 mm) fiberglass insulation in stud space.

### Two-Hour Fire Rating

Design Reference: UL U373, UL U375, ULC W312, WHI GP/WA 120-04, cUL U373, cUL U375, GA ASW 0810

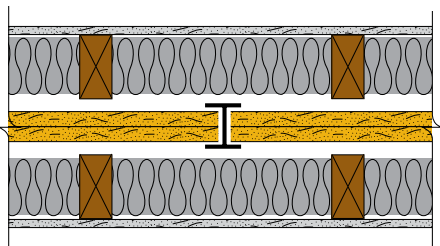

### 65-69 STC Sound Transmission

Test Reference: RAL TL 10-291

Two layers 1 in. (25.4 mm) DensGlass® Shaftliner inserted in H-Studs 24 in. (610 mm) o.c. Min. 3/4 in. (19 mm) air space on both sides must be maintained between liner panels and adjacent framing.

Sound Tested with 2 in. (51 mm) x 4 in. (102 mm) stud wall with 1/2 in. (12.7 mm) ToughRock® Gypsum Board each side of assembly and 3-1/2 in. (89 mm) fiberglass insulation in stud space both sides.

### Two-Hour Fire Rating

Design Reference: GP/WA 120-05 [WHI 495-0743, WHI 495-0743]

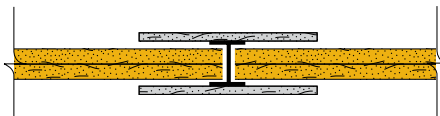

### 35-39 STC Sound Transmission Est.

Part. Thickness: 3 in. (76 mm)

Two layers 1 in. (25.4 mm) DensGlass® Shaftliner inserted in H-Studs 24 in. (610 mm) o.c. Metal covered using 6 in. (152 mm) wide 1/2 in. (12.7 mm) DensArmor Plus® Fireguard C® Interior Panels or 1/2 in. (12.7 mm) ToughRock® Fireguard C® Gypsum Board.

## Details

The following assemblies and details are for illustration purposes only. Please consult design authority and confirm code compliance. Georgia-Pacific Gypsum does not provide design services.

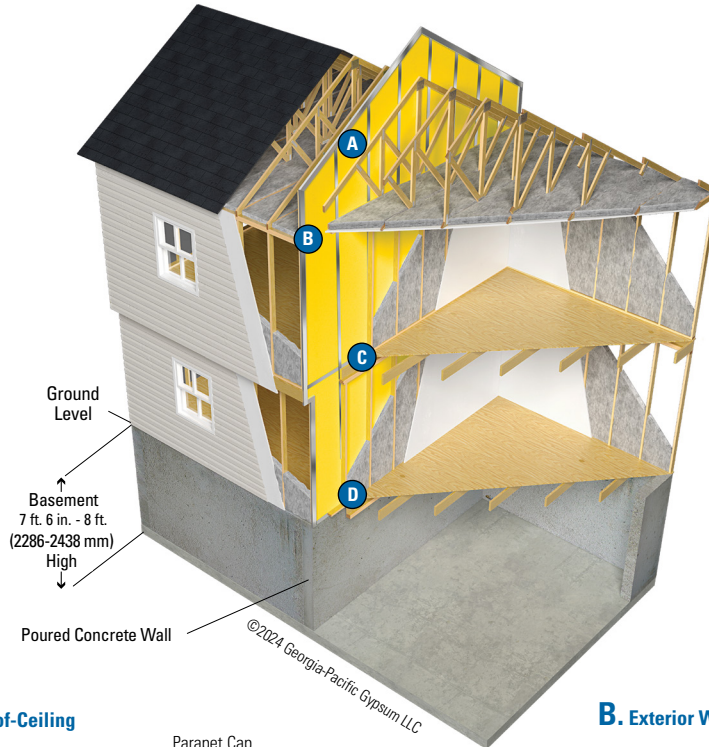

### A. Roof-Ceiling

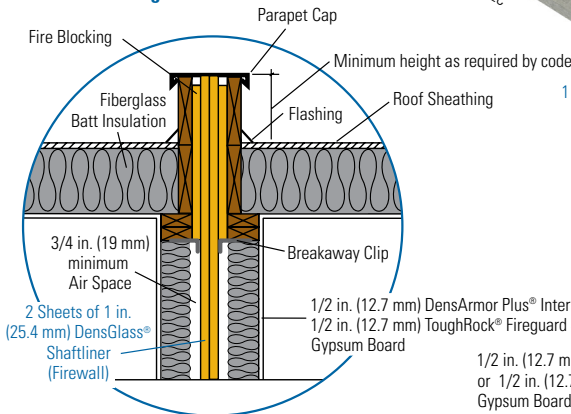

### B. Exterior Wall Intersection

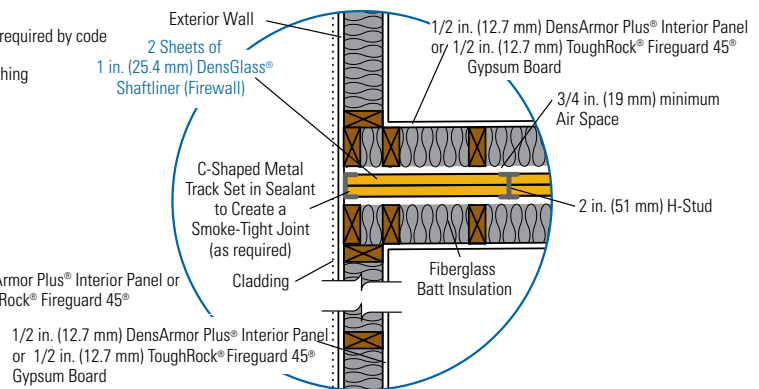

### C. Floor Intersection

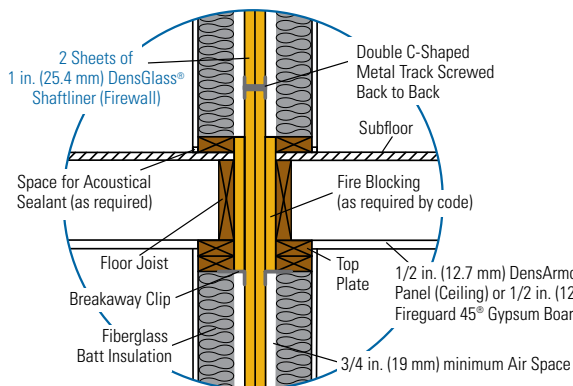

### D. Wall-to-Slab

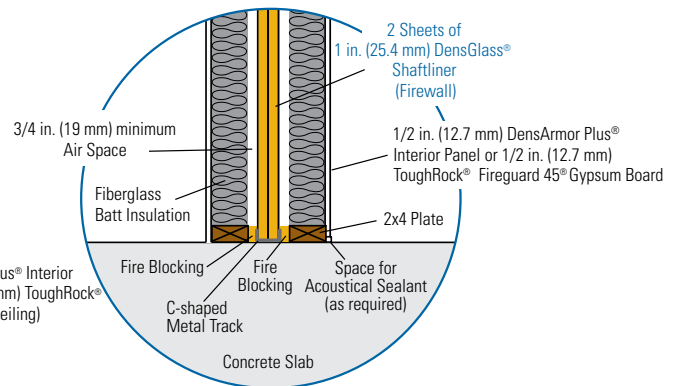

## Details continued

### Full Wall

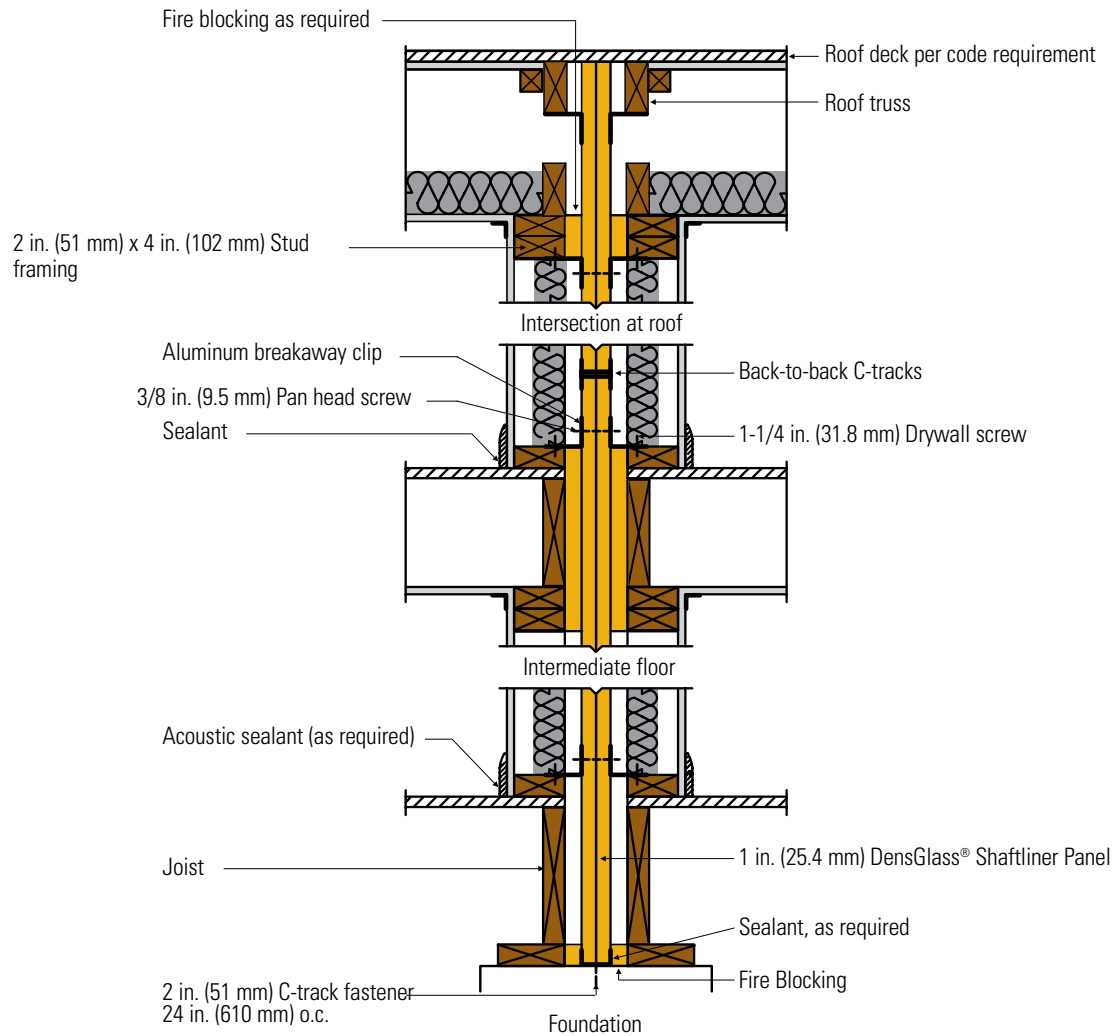

**Details continued**

**Attic-Adjacent to Trusses\***

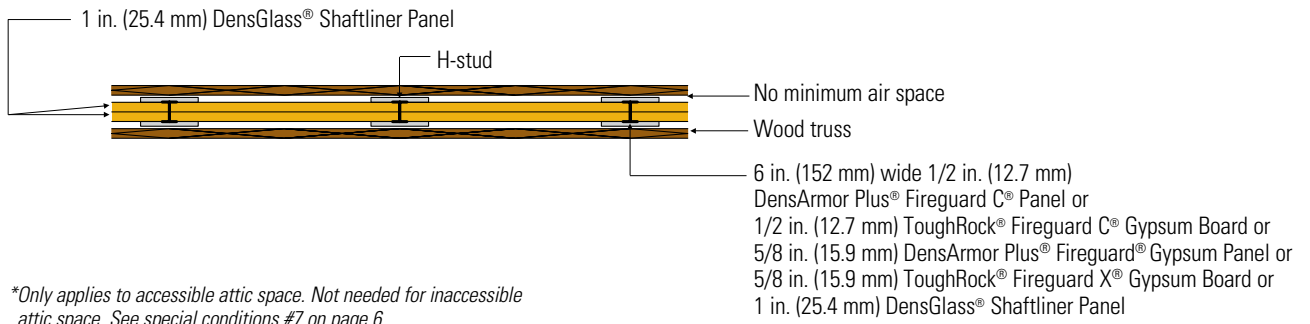

**Typical Roof Junction**

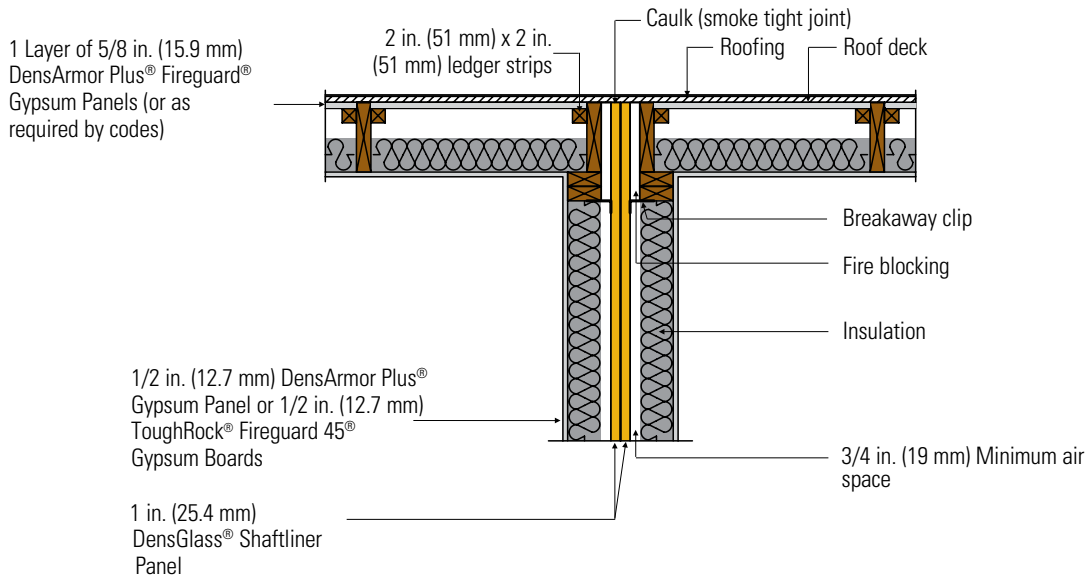

Details continued

Typical Offset Roof—1 Hour

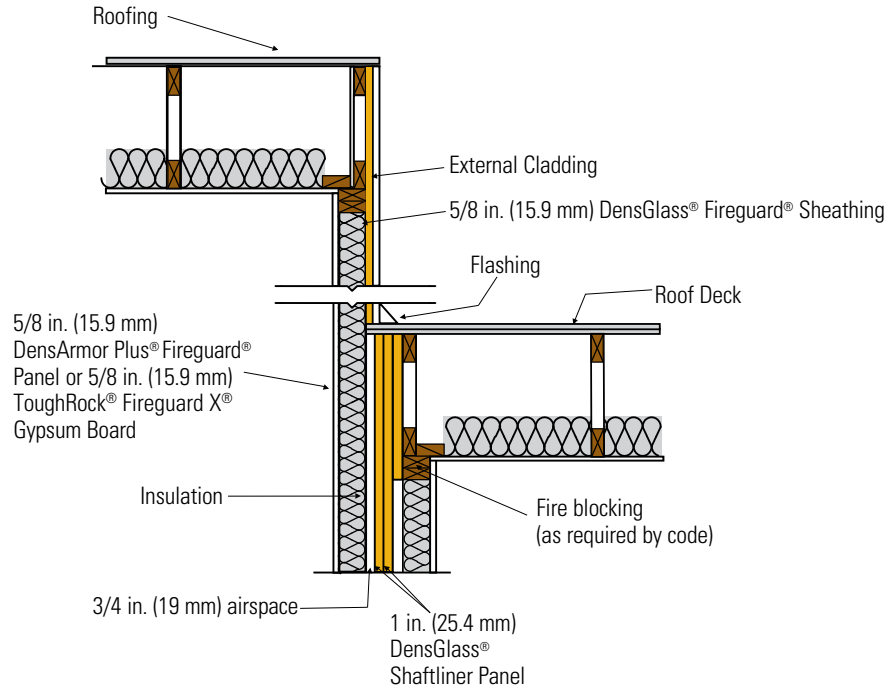

Typical Offset Roof—2 Hour

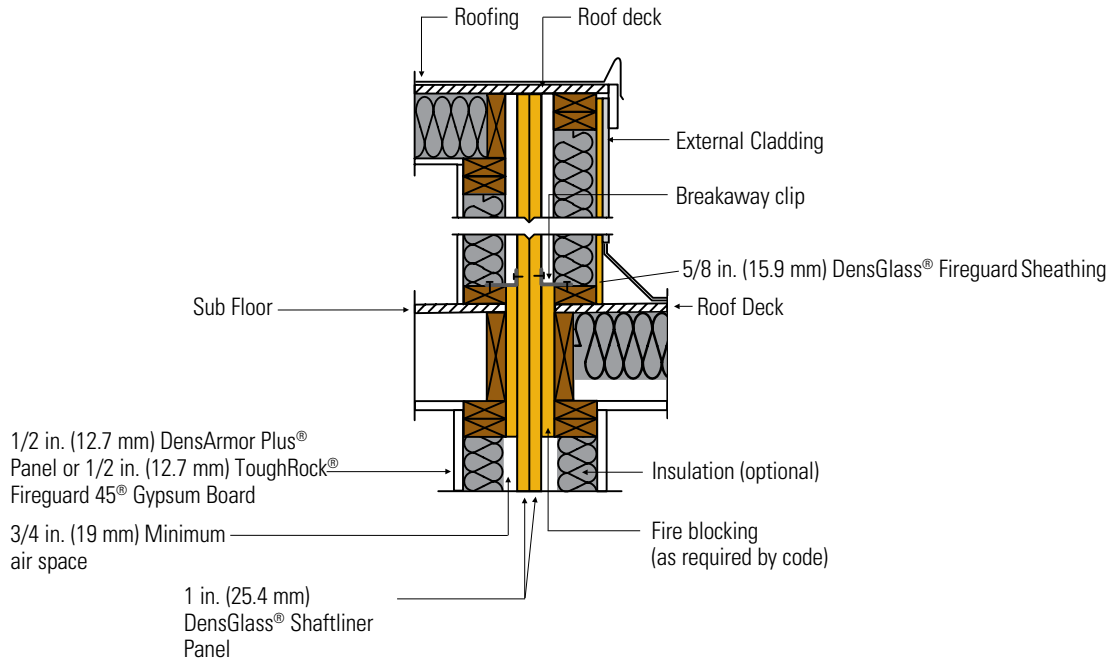

**Details continued**

**Typical Offset Wall—1 Hour**

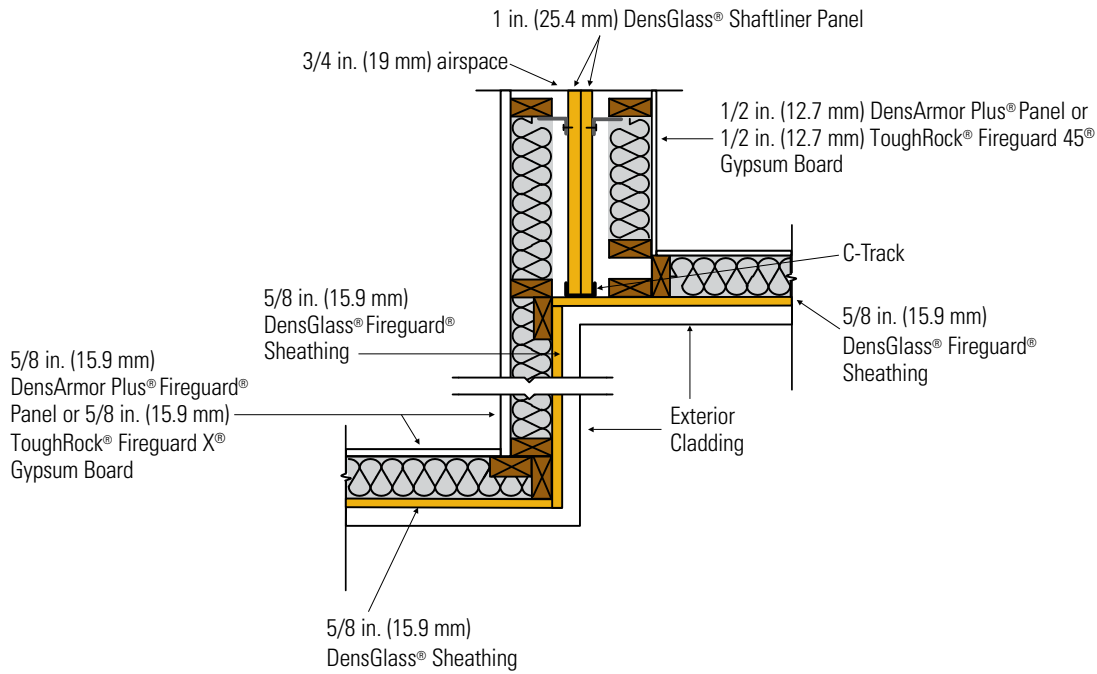

**Typical Offset Wall—2 Hour**

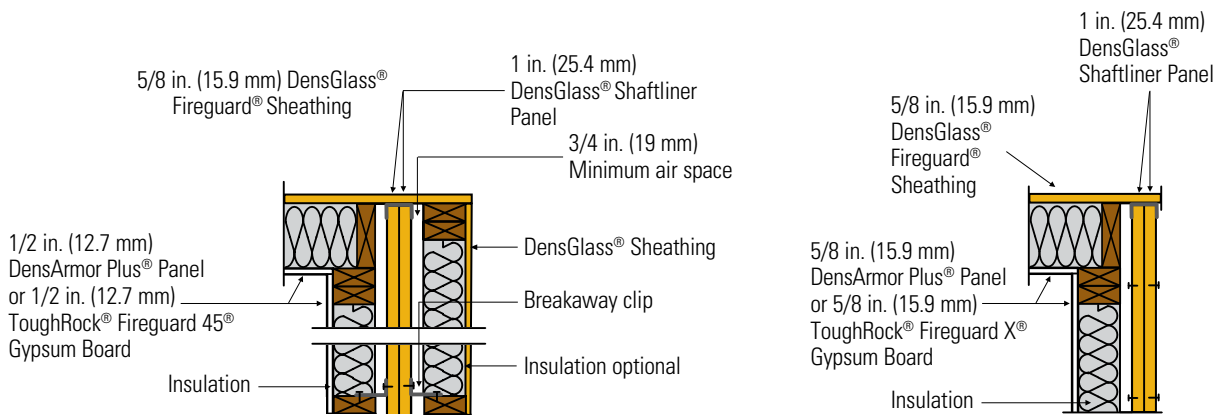

## Details continued

### Cantilever Detail

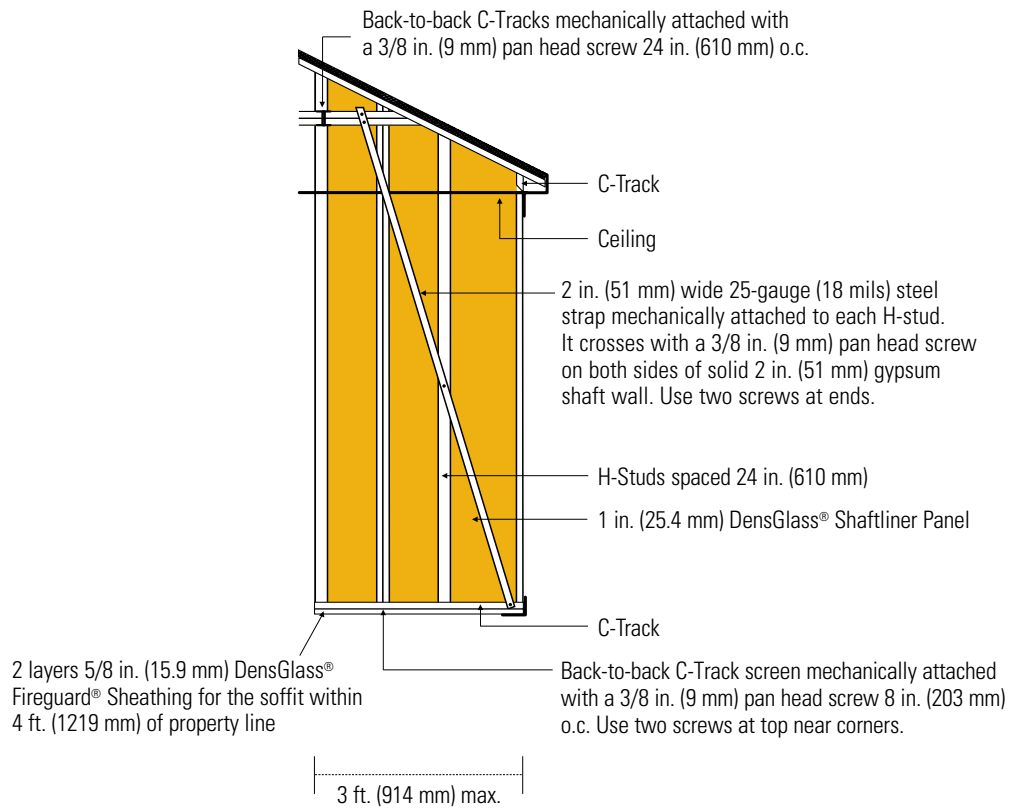

---

## Delivery, Handling and Storage

All materials shall be delivered in original bundles bearing the brand name, if any, applicable standard designation and name of the manufacturer or supplier for whom the product is manufactured. The plastic packaging used to wrap gypsum panel products for rail and/or truck shipment is intended to provide temporary protection from moisture exposure during transit only and is not intended to provide protection during storage after delivery. Such plastic packaging shall be removed immediately upon receipt of the shipment. **WARNING:** Failure to remove protective plastic shipping covers can result in condensation which can lead to damage, including mold.

All materials should be kept dry. Gypsum panel products shall be neatly stacked flat with care taken to prevent sagging or damage to edges, ends and surfaces. Gypsum panel products and accessories shall be properly supported on risers on a level platform, and fully protected from weather, direct sunlight exposure and condensation. Gypsum panel products shall be stacked flat rather than on edge or end. **WARNING:** Gypsum panel products stacked on edge or end can be unstable and present a serious hazard in the workplace should they accidentally topple.

Refer to the Gypsum Association's *Handling Gypsum Panel Products, GA-801*, for proper storage and handling requirements.

*Reference: Application and Finishing of Gypsum Panel Products, GA-216, Gypsum Association.*

**COMMONLY USED METRIC CONVERSIONS**

**Gypsum Board Thickness**

1/4 in. – 6 mm  
 1/2 in. – 12.7 mm  
 5/8 in. – 5.9 mm  
 1 in. – 25.4 mm

**Gypsum Board Width**

2 ft. – 610 mm  
 4 ft. – 1219 mm  
 32 in. – 813 mm

**Fastener Spacing**

4 in. – 1219 mm  
 5 in. – 1524 mm  
 8 in. – 2438 mm  
 9 in. – 2743 mm  
 10 in. – 3048 mm  
 12 in. – 3658 mm

**Framing Space**

16 in. – 406 mm  
 24 in. – 610 mm

**Fastener Spacing**

2 in. – 51 mm  
 2 1/2 in – 64 mm  
 7 in. – 178 mm  
 8 in. – 203 mm  
 12 in. – 305 mm  
 16 in. – 406 mm  
 24 in. – 610 mm

**Temperature**

40°F – 5°C  
 50°F – 10°C  
 125°F – 52°C

# High-Performance Gypsum Products from Georgia-Pacific

<b>DensDeck® Roof Board</b>	Fiberglass mat roof board used as the ideal thermal barrier and cover board to improve resistance to wind uplift, hail, foot traffic, fire and mold in a broad range of commercial roofing applications. Look for DensDeck® Prime Roof Board and DensDeck® StormX™ Prime Roof Board.
<b>DensGlass® Sheathing</b>	Original and universal standard of exterior gypsum sheathing that offers superior weather resistance, with a 12-month limited warranty against delamination or deterioration during exposure to normal weather conditions. Look for the familiar GOLD color. GREENGUARD listed for microbial resistance.
<b>DensGlass® Shaftliner</b>	Specially designed panel perfect for moisture-prone vertical or horizontal shafts, interior stairwells and area separation wall assemblies. Comes with a 12-month limited warranty against delamination or deterioration during exposure to normal weather conditions. GREENGUARD listed for microbial resistance.
<b>DensArmor Plus® Interior Panel</b>	High-performance interior panel that accelerates scheduling because it can be installed before the building is dried-in. Comes with a 12-month limited warranty against delamination or deterioration during exposure to normal weather conditions. GREENGUARD and GREENGUARD Gold certified for low VOC emissions. Listed in CHPS® High Performance Product Database as a low-emitting product. GREENGUARD listed for microbial resistance.
<b>DensShield® Tile Backer</b>	Acrylic-coated tile backer that stops moisture at the surface. Lightweight and strong, it is built for speed on the job site. Conforms to requirements of 2012 IBC/IRC Code. GREENGUARD listed for microbial resistance.
<b>ToughRock® Gypsum Board</b>	Paper-faced line of gypsum panels for a variety of applications, including interior wall and ceiling, and fire-rated assemblies. ToughRock® Products are GREENGUARD and GREENGUARD Gold certified for low VOC emissions. Listed in CHPS® High Performance Product Database as a low-emitting product.
<b>ToughRock® Mold-Guard™ Gypsum Board</b>	Gypsum board with enhanced mold resistance in comparison to regular ToughRock® Gypsum Boards. GREENGUARD and GREENGUARD Gold Certified for low VOC emissions and listed in the CHPS® High Performance Product Database as a low-emitting product. Also listed as GREENGUARD microbial resistant.
<b>DensElement® Barrier System</b>	Barrier system that delivers the same advantages of DensGlass® Sheathing while incorporating AquaKOR™ Technology, a water barrier system that maintains high vapor permeability mitigating the risk of moisture in the wall cavity. With this innovation built into its core, DensElement® Barrier System eliminates the need for an additional barrier (WRB-AB), saving time, labor and materials.



## Georgia-Pacific Gypsum

U.S.A. Georgia-Pacific Gypsum LLC  
CANADA Georgia-Pacific Canada LP

### SALES INFORMATION AND ORDER PLACEMENT

U.S.A. West: **1.800.824.7503**  
Midwest: **1.800.876.4746**  
South Central: **1.800.231.6060**  
Southeast: **1.800.327.2344**  
Northeast: **1.800.947.4497**

CANADA Canada Toll Free: **1.800.387.6823**  
Quebec Toll Free: **1.800.361.0486**

### TECHNICAL HOTLINE

U.S.A. and Canada: **1.800.225.6119**



### TRADEMARKS –

Unless otherwise noted, all trademarks are owned by or licensed to Georgia-Pacific Gypsum LLC. LEED, USGBC and related logo are trademarks owned by the U.S. Green Building Council and are used by permission. CHPS is a trademark owned by Collaborative for High Performance Schools Inc.

### WARRANTIES, REMEDIES AND TERMS OF SALE –

For current warranty information, please go to [buildgp.com/warranties](http://buildgp.com/warranties) and select the applicable product. All sales by Georgia-Pacific are subject to our Terms of Sale available at [buildgp.com/tc](http://buildgp.com/tc).

### UPDATES AND CURRENT INFORMATION –

The information in this document may change without notice. Visit our website at [buildgp.com](http://buildgp.com) for updates and current information.

**CAUTION: For product fire, safety and use information, go to [buildgp.com/safetyinfo](http://buildgp.com/safetyinfo) or call 1.800.225.6119.**

### HANDLING AND USE –

CAUTION: This product contains fiberglass facings which may cause skin irritation. Dust and fibers produced during the handling and installation of the product may cause skin, eye and respiratory tract irritation. Avoid breathing dust and minimize contact with skin and eyes. Wear long sleeve shirts, long pants and eye protection. Always maintain adequate ventilation. Use a dust mask or NIOSH/MSHA approved respirator as appropriate in dusty or poorly ventilated areas.

### FIRE SAFETY CAUTION –

Passing a fire test in a controlled laboratory setting and/or certifying or labeling a product as having a one-hour, two-hour, or any other fire resistance or protection rating and, therefore, as acceptable for use in certain fire rated assemblies/systems, does not mean that either a particular assembly/system incorporating the product, or any given piece of the product itself, will necessarily provide one-hour fire resistance, two-hour fire resistance, or any other specified fire resistance or protection in an actual fire. In the event of an actual fire, you should immediately take any and all actions necessary for your safety and the safety of others without regard for any fire rating of any product or assembly/system.

**buildgp.com**