

		GRABBER CONSTRUCTION PRODUCTS Joints							GrabberGard Products				
Joint Systems		Bottom of Wall	Floor to Floor	Floor to Wall	Head of Wall	Wall to Wall	Max Joint Width	Class	Movement Capabilities	I F C	F T C	F F S	Hourly Rating
		Bottom of Wall	BW-S-0009						3/4			✓	
	BW-S-0010						3/4				✓		1 & 2
Floor to Floor	FF-D-0047						1	II	25.0	✓			2
	FF-D-0048						1	II	25.0		✓		2
	FF-D-1059						4	II	12.5			✓	2
Floor to Wall	FW-D-0038						1	II	25.0	✓			2
	FW-D-0039						1	II	25.0		✓		2
	FW-D-1055						4	II	12.5			✓	2
Head of Wall	HW-D-0353						3/4	II	33.0	✓			1 & 2
	HW-D-0354						3/4	II	33.0			✓	2
	HW-D-0355						3/4	II	33.0	✓			1 & 2
	HW-D-0356						3/4	II	33.0	✓			1 & 2
	HW-D-0357						3/4	II	33.0			✓	1, 2, 3 & 4
	HW-D-0358						1	II	25.0			✓	1 & 2
	HW-D-0359						1	II	25.0			✓	2
	HW-D-0368						3/4	II	33.0		✓		1 & 2
	HW-D-0369						3/4	II	33.0		✓		2
	HW-D-0370						3/4	II	33.0		✓		1 & 2
	HW-D-1050						4	II	12.5			✓	2

		GRABBER CONSTRUCTION PRODUCTS Wall Exterior							Framing			Hourly Rating	
Curtain Wall		Steel	Glass	Tilt-Up Panels	Concrete Panels	Aluminum Panels	Brick Veneer	Stone Veneer	EIFS	S t e e l	A l u m i n i u m	N / A	Hourly Rating
		Curtain Wall	CW-S-1011									✓	
	CW-S-2054										✓		2

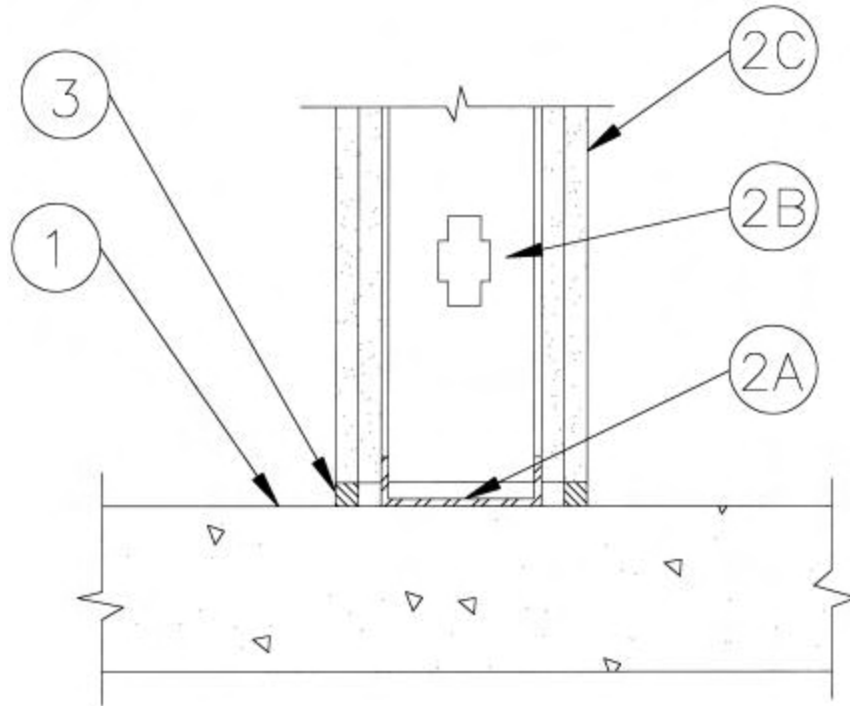

System No. BW-S-0009
Assembly Ratings 1 & 2 Hr (See Item 2)
Nominal Joint Width – 3/4 in.



1. **Floor Assembly** — Min 4-1/2 in. thick reinforced lightweight or normal weight (100-150 pcf) structural concrete. Floor may also be constructed of any 6 in. thick UL Classified hollow-core **Precast Concrete Units***. See **Precast Concrete Units** category in the Fire Resistance Directory for names of manufactures.

2. **Wall Assembly** — The 1 or 2 hr fire-rated gypsum board/steel stud wall assembly shall be constructed of the materials and in the manner specified in the individual U400 or V400 Series Wall or Partition Design in the UL Fire Resistance Directory. In addition, the wall may incorporate a head-of-wall joint system constructed as specified in the HW Series Joint Systems in the UL Fire Resistance Directory. The wall shall include the following construction features:

- A. **Steel Floor Runner** — Floor runners of wall assembly shall consist of min No. 25 gauge galv steel channels sized to accommodate steel studs (Item 2B). Floor runners to be provided with min 1-1/4 in. flanges. Runners secured with steel fasteners spaced 12 in. OC.
- B. **Studs** — Steel studs to be min 2-1/2 in. wide. Studs cut 1/2 to 3/4 in. less in length than assembly height with bottom nesting in, resting on and fastened to floor runner with sheet metal screws. Stud spacing not to exceed 24 in. OC.
- C. **Gypsum Board*** — Gypsum board installed to a min total thickness of 5/8 or 1-1/4 in. on each side of wall for a 1 or 2 hr rated wall, receptively. Wall to be constructed as specified in the individual U400 or V400 Series Design in the UL Fire Resistance Directory, except that a max 3/4 in. gap shall be maintained between the bottom of gypsum board and top of concrete floor.

The hourly fire rating of the joint system is equal to the hourly fire rating of the wall.

3. **Fill, Void or Cavity Material* Sealant** — **Max separation between top of floor and bottom of gypsum board is 3/4 in.** Min 5/8 in. thickness of fill material installed on each side of the wall between the bottom of the gypsum board and the top of the concrete floor, flush with each surface of the wall.

John Wagner & Associates Inc. – GrabberGard IFC

*Bearing the UL Classification Mark



System No. BW-S-0010
Assembly Ratings 1 & 2 Hr (See Item 2)
Nominal Joint Width – 3/4 in.

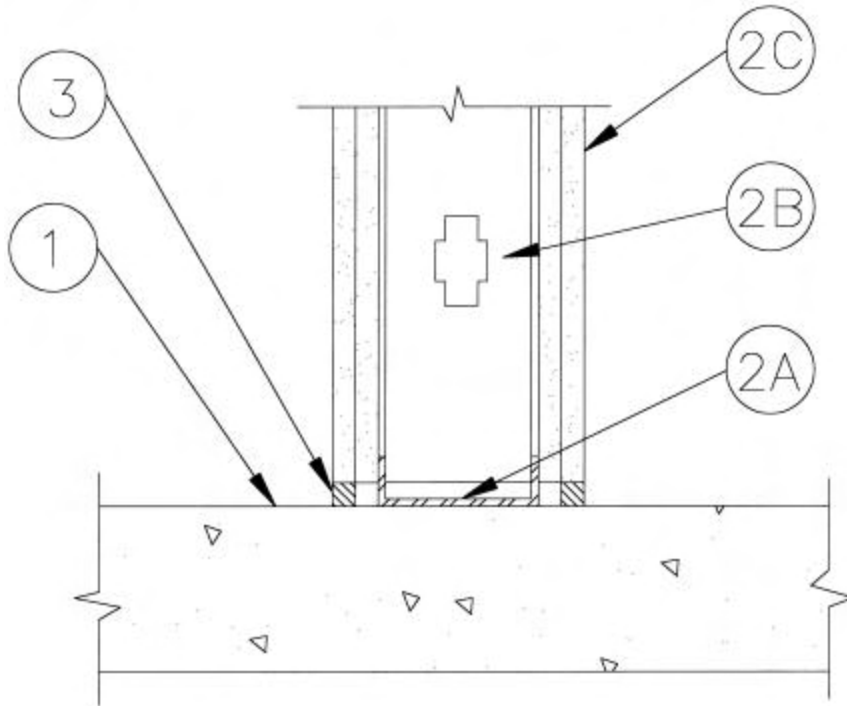

1. **Floor Assembly** — Min 4-1/2 in. thick reinforced lightweight or normal weight (100-150 pcf) structural concrete. Floor may also be constructed of any 6 in. thick UL Classified hollow-core **Precast Concrete Units***. See **Precast Concrete Units** category in the Fire Resistance Directory for names of manufactures.

2. **Wall Assembly** — The 1 or 2 hr fire-rated gypsum board/steel stud wall assembly shall be constructed of the materials and in the manner specified in the individual U400 or V400 Series Wall or Partition Design in the UL Fire Resistance Directory. In addition, the wall may incorporate a head-of-wall joint system constructed as specified in the HW Series Joint Systems in the UL Fire Resistance Directory. The wall shall include the following construction features:

- A. **Steel Floor Runner** — Floor runners of wall assembly shall consist of min No. 25 gauge galv steel channels sized to accommodate steel studs (Item 2B). Floor runners to be provided with min 1-1/4 in. flanges. Runners secured with steel fasteners spaced 12 in. OC.
- B. **Studs** — Steel studs to be min 2-1/2 in. wide. Studs cut 1/2 to 3/4 in. less in length than assembly height with bottom nesting in, resting on and fastened to floor runner with sheet metal screws. Stud spacing not to exceed 24 in. OC.
- C. **Gypsum Board*** — Gypsum board installed to a min total thickness of 5/8 or 1-1/4 in. on each side of wall for a 1 or 2 hr rated wall, receptively. Wall to be constructed as specified in the individual U400 or V400 Series Design in the UL Fire Resistance Directory, except that a max 3/4 in. gap shall be maintained between the bottom of gypsum board and top of concrete floor.

The hourly fire rating of the joint system is equal to the hourly fire rating of the wall.

3. **Fill, Void or Cavity Material* Sealant** — **Max separation between top of floor and bottom of gypsum board is 3/4 in.** Min 5/8 in. thickness of fill material installed on each side of the wall between the bottom of the gypsum board and the top of the concrete floor, flush with each surface of the wall.

John Wagner & Associates Inc. – GrabberGard EFC

*Bearing the UL Classification Mark



System No. CW-S-1011
Integrity Rating — 2 Hr
Insulation Rating — 1/4 Hr
Linear Opening Width — 2-1/2 In. Max
L Rating At Ambient – Less Than 1 CFM/Lin Ft

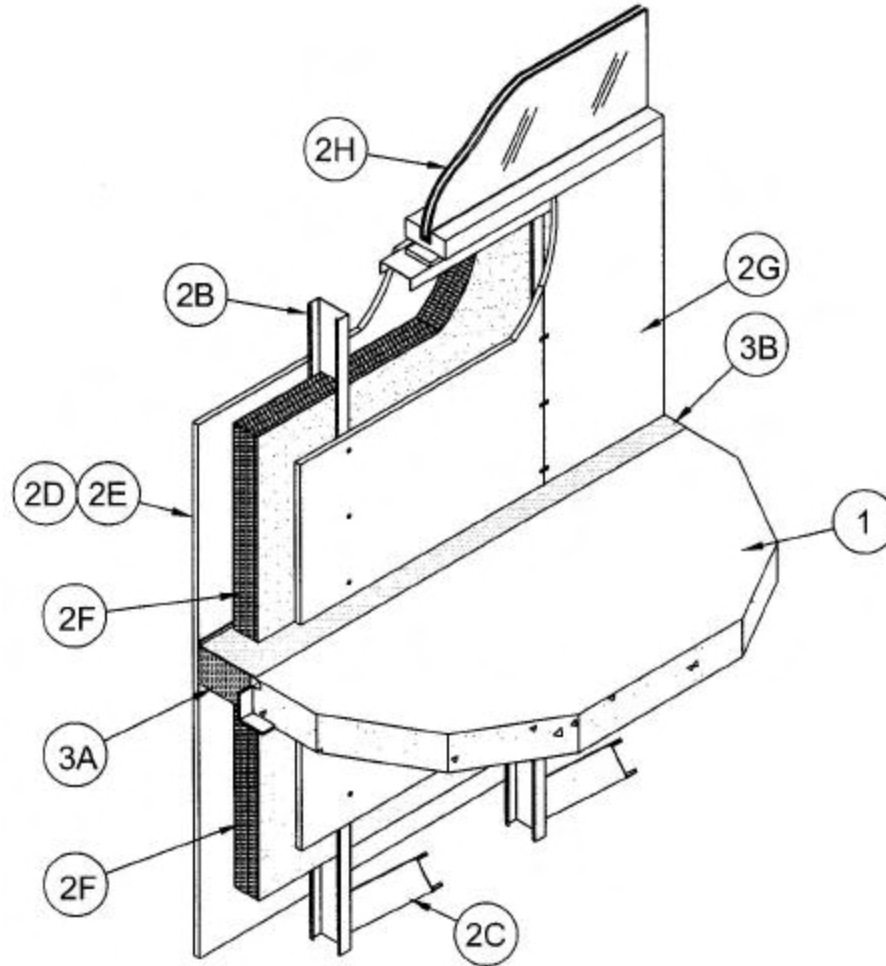

1. **Floor Assembly** – Min 4-1/2 in. thick reinforced lightweight or normal weight (100-150 pcf) structural concrete. Perimeter of floor assembly to be provided with min 3by 3 by 1/4 in. thick cast-in-place structural steel angle for weld-attachment of mullion mounting clips (Item 2A).
2. **Curtain Wall Assembly** – The curtain wall assembly shall incorporate the following construction features:
 - A. **Mounting Angles** (Not Shown) - Min 3 in. long angles with one nom 4 in. leg for attachment to edge of floor assembly and with one leg approx 2-1/2 to 3 in. longer than distance to interior face of steel studs. Angles to be formed of min 1/8 in. thick steel. Angles welded to cast-in-place structural steel angle at edge of floor assembly (Item 1) on one side of each steel stud (Item 2B) at each floor level. Top edge of each mounting angle to be recessed 1 to 1-1/2 in. below top surface of floor.
 - B. **Steel Studs** – C-shaped studs formed from min 0.034 in. thick (20 ga) galv steel. The steel studs shall be -1/2 in. to 6 in. wide by 1-1/4 in. deep with 5/16 in. wide stiffening flanges and shall be assembled using runner channels formed from min 0.034 in. thick galv steel. Studs spaced max 24 in. OC and welded, bolted or screwed to mounting angles (Item 2A) at each floor level. When cementitious backer units (Item 2E) are used for exterior sheathing, max stud spacing is 16 in. OC. Interior face of studs to be max 2-1/2 in. from edge of floor assembly.



- C. **Steel Struts** – Short lengths of steel stud (Item 2B) used to brace each steel stud against lateral movement. One end of strut bolted, screwed or welded to steel stud beneath plane of floor assembly. Opposite end of strut anchored to underside of floor.
- D. **Gypsum Board*** – One layer of nom 5/8 in. thick, 48 in. wide gypsum sheathing installed to cover entire exterior surface of wall. Sheathing applied with joints centered over studs and secured to steel studs with min 1 in. long bugle head steel screws spaced max 8 in. OC along the edges and max 12 in. OC in the field of each sheet.
- E. **Cementitious Backer Units*** – As an alternate to the gypsum sheathing (Item 2D), nom 1/2 in. or 5/8 in. thick square-edge boards attached to studs with 1-1/4 in. long corrosion resistant self-tapping wafer-head steel screws spaced 6 in OC. Joints covered with glass fiber mesh tape.
UNITED STATES GYPSUM CO — Durock Exterior Cement Board, Durock Cement Board or Durock WMB
- F. **Batts and Blankets*** – Any glass fiber insulation bearing the UL Classification Marking as to fire resistance or surface burning characteristics, of a thickness to completely fill stud cavity. Insulation batts friction fit to completely fill all stud cavities of curtain wall above the top of the fill material (Item B) and below the forming material (Item 3A).
See **Batts and Blankets (BZJZ)** category for names of manufacturers.
- G. **Gypsum Board*** – One layer of nom 5/8 in. thick, 48 in. wide gypsum board applied with joints centered over studs. Gypsum board secured to steel studs on interior surface of curtain wall with min 1 in. long bugle head steel screws spaced max 8 in. OC along the edges and max 12 in. OC in the field of each sheet. Gypsum board installed to cover interior surface of wall above the top of the fill material (Item 3C) and below the forming material (Item 3B).
- H. **Framed Window** - Metal-framed window with nom 1/4 in. thick heat-strengthened glass. Sill of window to be min 34 in. above top of floor slab. Top of window to be min 33 in. below bottom of floor slab.
- I. **Siding, Brick or Stucco** – (Not Shown) – Aluminum siding, steel siding, brick veneer or stucco installed over gypsum sheathing or cementitious backer units and meeting the requirements of local code agencies. Brick veneer wall attached to studs with corrugated metal wall ties attached to each stud with steel screws.
3. **Safing System** – The safing system shall incorporate the following construction features:
- A. **Forming Material*** – Nom 4 pcf density mineral wool batt insulation. Batt sections to be cut to a min width of 4 in. and stacked to a thickness which is 20 percent greater than the width of linear gap between the gypsum sheathing and the edge of the concrete floor. The forming material is compressed and inserted cut-edge-first into linear gap between edge of floor slab and sheathing material such that its top surface is flush with the top surface of the floor assembly. Length of batt to be equal to on-center spacing of steel studs such that it is friction-fitted between studs and mounting angles without seams. Additional pieces of mineral wool batt to be stuffed inside the channel of each steel stud throughout the thickness of the forming material.
ROXUL INC — SAFE
- B. **Fill, Void or Cavity Material*** – Min 1/16 in. thickness (dry) of fill material spray-applied over top of forming material and lapping min 1/2 in. onto the top surface of the floor and onto the gypsum sheathing and steel studs.
John Wagner & Associates Inc. – GrabberGard EFS

*Bearing the UL Classification Mark



System No. CW-S-2054
Integrity Rating — 2 Hr
Insulation Rating — 1/4 Hr
Linear Opening Width — 8 In. Max

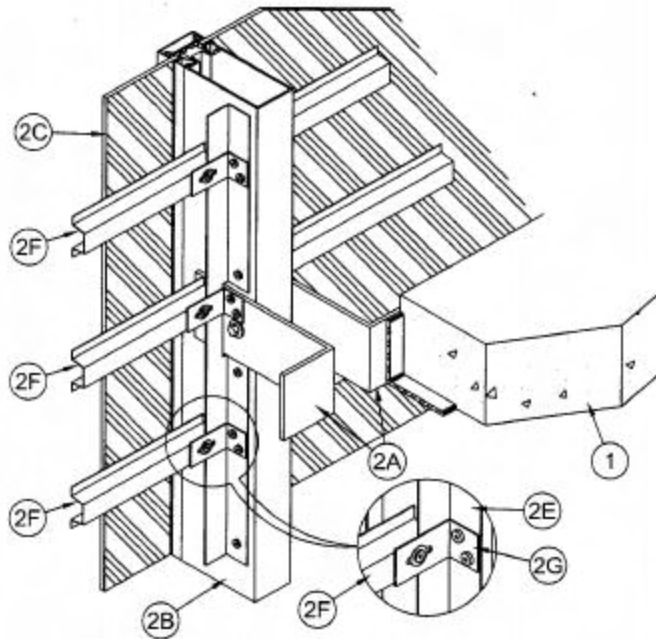
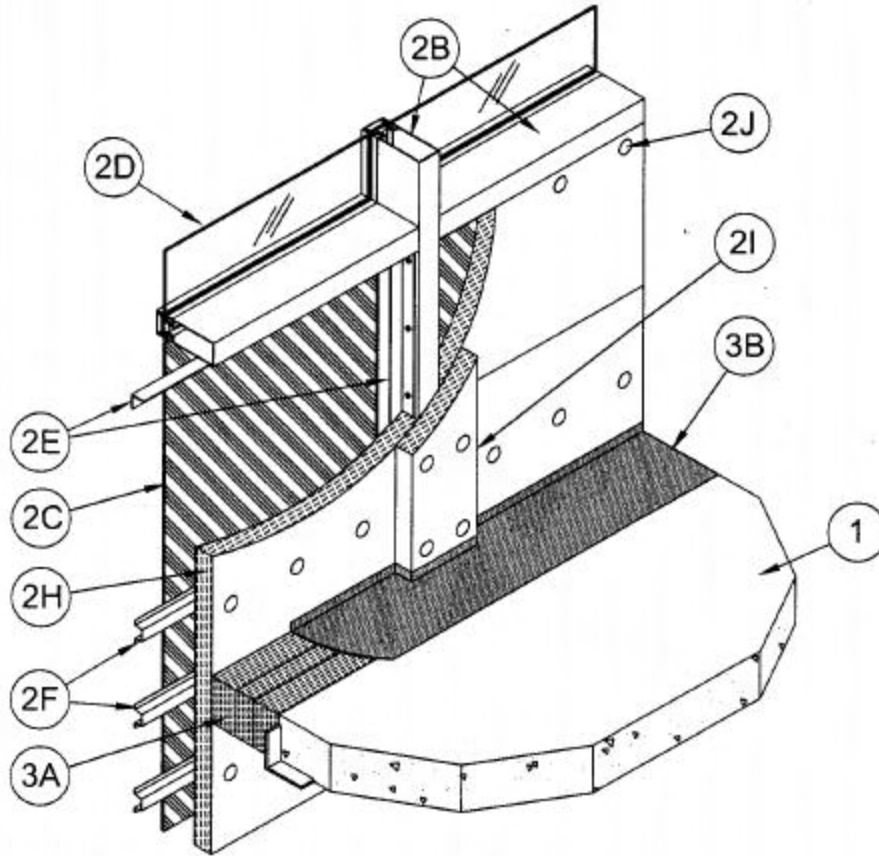



1. **Floor Assembly** – Min 4-1/2 in. thick reinforced lightweight or normal weight (100-150 pcf) structural concrete. Perimeter of floor assembly to be provided with min 4 by 4 by 1/4 in. thick cast-in-place structural steel angle for weld-attachment of mullion mounting clips (Item 2A).
2. **Curtain Wall Assembly** – The curtain wall assembly shall incorporate the following construction features:
 - A. **Mullion Mounting Clips** – Min 4 in. long angles with one nom 4 in. leg for attachment to edge of floor assembly and with one leg approx 4 in. longer than distance to nearest face of mullion. Clips welded to steel angle at edge of floor assembly (Item 1) on each side of vertical mullion (Item 2B) at each floor level. Top edge of each mounting angle to be recessed min 1/2 in. below top surface of floor.
 - B. **Framing** – The rectangular tubing mullions (vertical members) and transoms (horizontal members) shall be minimum 2-1/2 in. wide by 5 in. deep and shall be formed from min 0.100 in. thick aluminum. Mullions spaced max 60 in. OC and secured to mullion mounting clips (Item 2A) at each floor level with two 1/2 in. diam by 4 in. long hex head steel bolts in conjunction with steel nuts and washers. Interior face of mullions to be max 8 in. from edge of floor assembly. Transoms framing top and bottom edges of spandrel panels (Item 2C) to be spaced min 72 in. OC. Transom forming sill of vision panel (Item 2D) to be located such that its bottom surface is at height of 33 in. above the top surface of the floor (Item 1).
 - C. **Spandrel Panels** – Each panel secured in position with aluminum pressure plates in conjunction with gaskets and steel screws. The following types of spandrel panels may be used:
 1. Nom 1/4 in. thick opaque heat-strengthened or tempered glass.
 2. Nom 1-3/16 in. thick polished granite spandrel panels with 1 in. thick gauged edges.
 3. Nom 1/8 in. thick aluminum panels with 1/4 in. thick edges.
 - D. **Vision Panels** – Nom 1/4 in. thick transparent heat-strengthened glass. Each panel secured in position with aluminum pressure plates in conjunction with glazing gaskets and steel screws.
 - E. **Spandrel Panel Perimeter Angles** – Nom 1-1/2 by 1-1/2 in. No. 22 gauge galvanized steel angles installed around entire perimeter of each spandrel panel. Angles recessed from interior face of framing as necessary to accommodate thickness of curtain wall insulation (Item 2H). Angles notched as necessary to be continuous over mullion mounting clips (Item 2A). Angles screw-attached to mullions and transom along sides and top of each spandrel panel with No. 10 by 1/2 in. long self-drilling, self-tapping steel screws spaced max 12 in. OC. Angle along bottom of each spandrel panel to be screw-attached to leg of angle on mullion at each end without any direct attachment to transom.
 - F. **Stiff Back Channel** – Nom 2-1/2 in. wide by 7/8 in. deep hat-shaped channel formed of 22 gauge galv steel to be installed to stiffen curtain wall insulation between mullions above and below and at elevation of safing joint. One stiff back channel to be located with its centerline approx 6 in. below floor and one stiff back channel to be located with its centerline approx 6 in. above floor. A third stiff back channel is to be located near the midheight of the safing joint. A clearance of 1/4 to 1/2 in. shall be maintained between the ends of the stiff back channels and the mullions. Stiff back channel secured to mullion at each end with channel attachment clip (Item 2G) in conjunction with a No. 8 by 1/2 in. long self-drilling, self-tapping wafer head steel screw or a 3/16 in. diam steel bolt with nut and washer.
 - G. **Channel Attachment Clip** – Nom 1-1/2 by 2-1/2 by 1-1/2 in. long angle formed of 16 gauge galv steel. The 2-1/2 in. leg is provided with a 1/4 in. wide by 1-1/2 in. long slot along its centerline for attachment of the stiff back channel. Clips secured to mullions mounting clips (Item 2A) and mullions, through perimeter angles, with two No. 10 by 1/2 in. long self-drilling, self-tapping steel screws. Channel clips installed with 2-1/2 in. leg recessed from interior face of mullion to accommodate thickness of curtain wall insulation (Item 2H).



H. **Curtain Wall Insulation*** – Min 2 in. thick mineral wool board insulation, unfaced or faced on one side with aluminum foil/scrim vapor retarder, supplied in min 36 in. wide boards. Insulation boards to be installed with no vertical seams and with horizontal seams spaced min 24 in. OC. A full-width board shall be centered at the midheight of floor and tightly-fitted between vertical mullions, flush with interior surface of framing. The centered board shall be secured to the stiff back channels (Item 2F) located approx 6 in. above and below the floor with cup head weld pins (Item 2J) spaced max 10 in. OC along each channel. The remainder of the spandrel panel framing above and below the centered full-width board shall be filled in with additional lengths of board cut to fit tightly between mullions and with the horizontal seams between board sections tightly butted. The boards shall be secured to the spandrel panel perimeter angles with cup head weld pins at each corner of each board and spaced max 10 in. OC. When faced boards are used, butted seams to be covered with min 4 in. wide aluminum foil tape.

ROXUL INC — RHT-80

I. **Framing Covers – Curtain Wall Insulation*** – Min 8 in. wide strips cut from the same min 2 in. thick mineral wool batt insulation used for the curtain wall insulation (Item 2H). Framing covers to be centered over mullions and secured to the spandrel panel perimeter angles (Item 2E) with cup head weld pins (Item 2J) spaced max 12 in. OC. Where more than one spandrel panel occurs between vertically separated vision panels, the horizontal transom between spandrel panels shall also be covered with an 8 in. wide framing cover in the same manner as on the vertical mullions. Framing covers on mullions to abut the mineral wool batt safing material (Item 3A) above and below floor.

ROXUL INC — RHT-80

J. **Weld Pin** - No. 12 gauge galv steel weld pin with nom 1-3/16 in. diam galv steel cup head. Cup head weld pins provided in two lengths. One length to be equal to thickness of curtain wall insulation (Item 2H) and second length to be equal to thickness of curtain wall insulation plus thickness of framing cover (Item 2I). Cup head weld pins inserted through curtain wall insulation and mullion covers and welded to spandrel panel perimeter angles at max OC spacings referenced in Items 2H and 2I.

3. **Perimeter Fire Containment System** – The perimeter fire containment system shall incorporate the following construction features:

A. **Forming Material*** – Nom 4 in. thick, mineral wool batt safing material to be installed in continuous pieces between mullion clips. Safing material to be cut to a 4-1/2 in. width and stacked to a thickness which is at least 25 percent greater than the width of the linear gap between the curtain wall and the edge of the concrete floor slab. The safing material is compressed and inserted cut-edge-first into the linear gap and recessed from top surface of floor to accommodate the required thickness of fill material. Additional pieces of safing material to be friction-fit into space between mullion mounting clips at each mullion location with top edges of mullion clips covered with a min 1/2 in. thickness of compressed safing material.

ROXUL INC — SAFE

B. **Fill, Void or Cavity Material* – Sealant** – Min 1/16 in. thickness (dry) of fill material applied within the joint, flush with top surface of floor.

John Wagner & Associates Inc. – GrabberGard EFS

*Bearing the UL Classification Mark



System No. FF-D-0047

Assembly Rating – 2 hr

Nominal Joint Width – 1 in.

Class II Movement Capabilities – 25% Compression or Extension

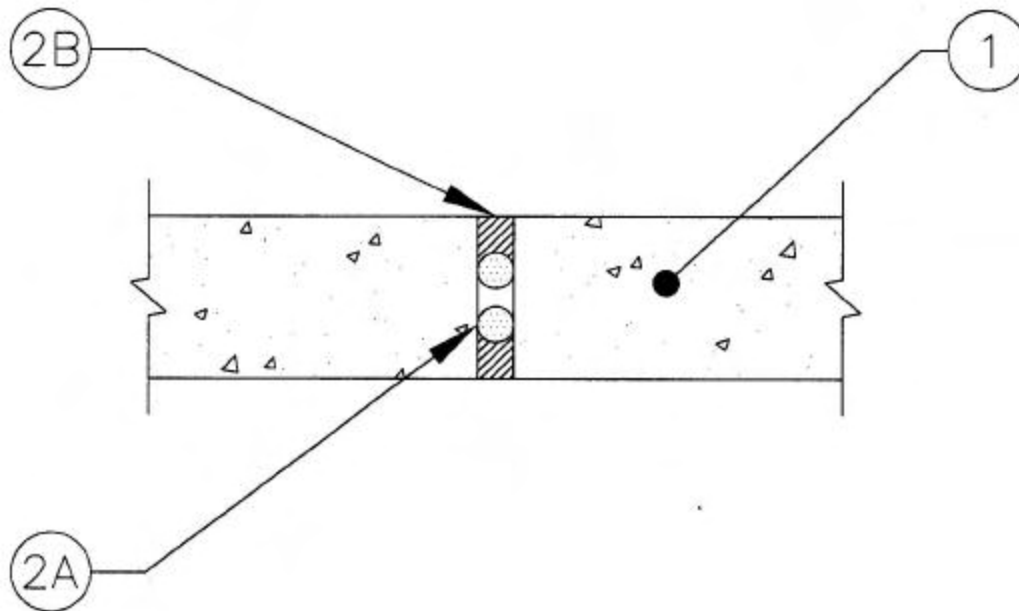

1. **Floor Assembly** – Min 4-1/2 in. thick steel-reinforced lightweight or normal weight (100-150 pcf) structural concrete.
2. **Joint Systems** – Max width of joint (at time of installation of joint system) is 1 in. The joint system is designed to accommodate a max 25 percent compression or extension from its installed width. The joint system shall consist of the following:
 - A. **Packing Material – Backer Rod** – Nom 1-1/4 in. diam polyethylene backer rod compressed and firmly packed into joint opening and recessed from both sides of floor to accommodate required thickness of fill material.
 - B. **Fill, Void or Cavity Material – Sealant** – Min 1 in. thickness of fill material applied within the joint, flush with both surfaces of floor.

John Wagner & Associates Inc. – GrabberGard IFC



System No. FF-D-0048

Assembly Rating – 2 hr

Nominal Joint Width – 1 in.

Class II Movement Capabilities – 25% Compression or Extension

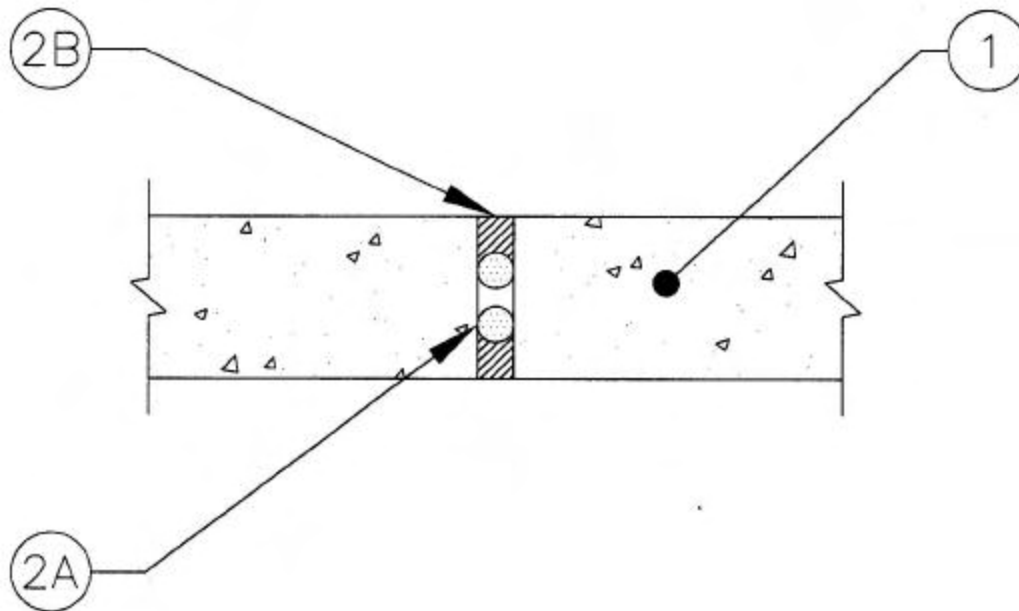

1. **Floor Assembly** – Min 4-1/2 in. thick steel-reinforced lightweight or normal weight (100-150 pcf) structural concrete.
2. **Joint Systems** – Max width of joint (at time of installation of joint system) is 1 in. The joint system is designed to accommodate a max 25 percent compression or extension from its installed width. The joint system shall consist of the following:
 - A. **Packing Material – Backer Rod** – Nom 1-1/4 in. diam polyethylene backer rod compressed and firmly packed into joint opening and recessed from both sides of floor to accommodate required thickness of fill material.
 - B. **Fill, Void or Cavity Material – Sealant** – Min 1 in. thickness of fill material applied within the joint, flush with both surfaces of floor.

John Wagner & Associates Inc. – GrabberGard EFC



System No. FF-D-1059

Assembly Rating – 2 Hr

Joint Width – 4 in. Max

Class II Movement Capabilities – 12.5% Compression or Extension

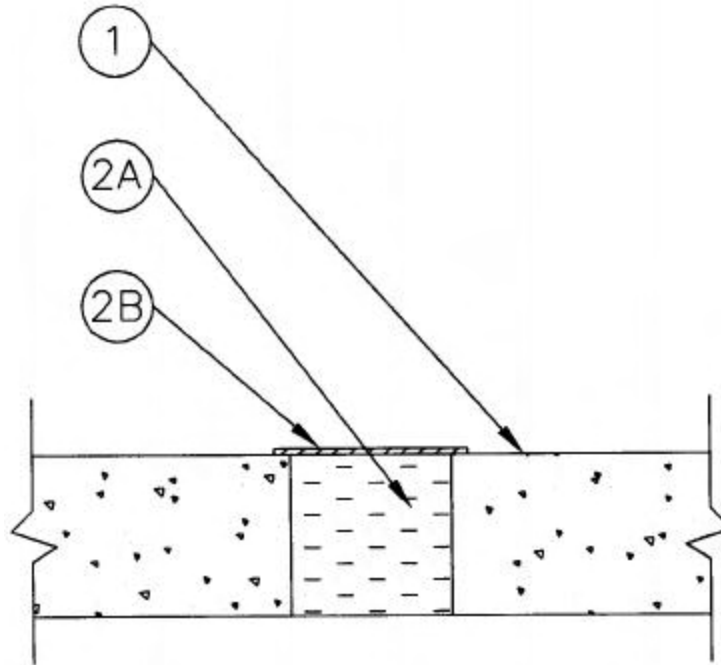

1. **Floor Assembly** – Min 4 1/2 in. thick steel-reinforced lightweight or normal weight (100-150 pcf) structural concrete.
2. **Joint System** – Max width of joint (at time of installation of joint system) is 4 in. The joint system is designed to accommodate a max 12.5 percent compression or extension from its installed width. The joint system shall consist of the following:
 - A. **Forming Material*** – Min 4 pcf mineral wool batt insulation installed into joint opening as a permanent form. Batt cut to min width of 4 1/2 in. and installed edge-first into joint opening, parallel with joint direction, such that batt sections are compressed min 33 percent in thickness and such that the compressed batt sections are flush with the top surface of floor.
 - Owens Corning** – Paroc Safing Insulation
 - Thermafiber LLC** – Type SAF
 - Rock wool Manufacturing Company** – Delta Safing Board
 - B. **Fill, Void or Cavity Material* – Sealant** – Min 1/16 in. dry thickness of fill material sprayed or brushed on top surface of floor to completely cover mineral wool and overlap a min of 1/2 in. onto concrete floor.
 - Grabber®** – GrabberGard EFS

*Bearing the UL Classification Marking



System No. FW-D-0038

Assembly Rating – 2 hr

Nominal Joint Width – 1 in.

Class II Movement Capabilities – 25% Compression or Extension

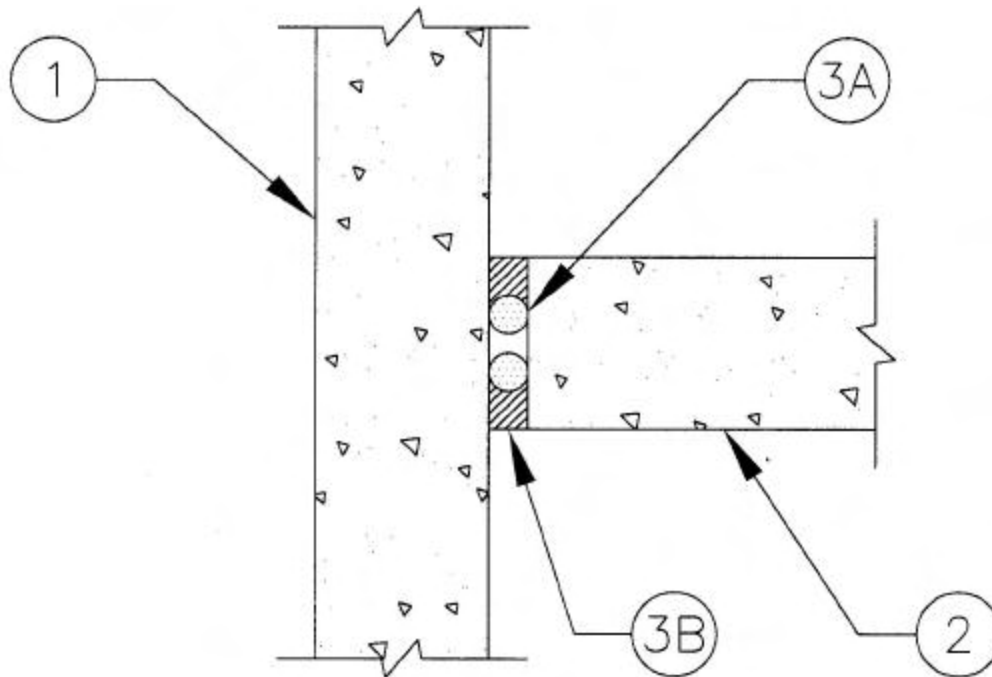

1. **Wall Assembly** – Min 4-1/2 in. thick reinforced lightweight or normal weight (100-150 pcf) structural concrete. Wall may also be constructed of any UL Classified **Concrete Blocks***.
See Classified **Concrete Blocks** (CATZ) category in the Fire resistance Directory for names of manufactures.
2. **Floor Assembly** – Min 4-1/2 in. thick steel-reinforced lightweight or normal weight (100-150 pcf) structural concrete.
3. **Joint Systems** – Max width of joint (at time of installation of joint system) is 1 in. The joint system is designed to accommodate a max 25 percent compression or extension from its installed width. The joint system shall consist of the following:
 - A. **Packing Material – Backer Rod** – Nom 1-1/4 in. diam polyethylene backer rod compressed and firmly packed into joint opening and recessed from both sides of wall to accommodate required thickness of fill material.
 - B. **Fill, Void or Cavity Material – Sealant** – Min 1 in. thickness of fill material applied within the joint, flush with both surfaces of wall.

John Wagner & Associates Inc. – GrabberGard IFC



System No. FW-D-0039

Assembly Rating – 2 hr

Nominal Joint Width – 1 in.

Class II Movement Capabilities – 25% Compression or Extension

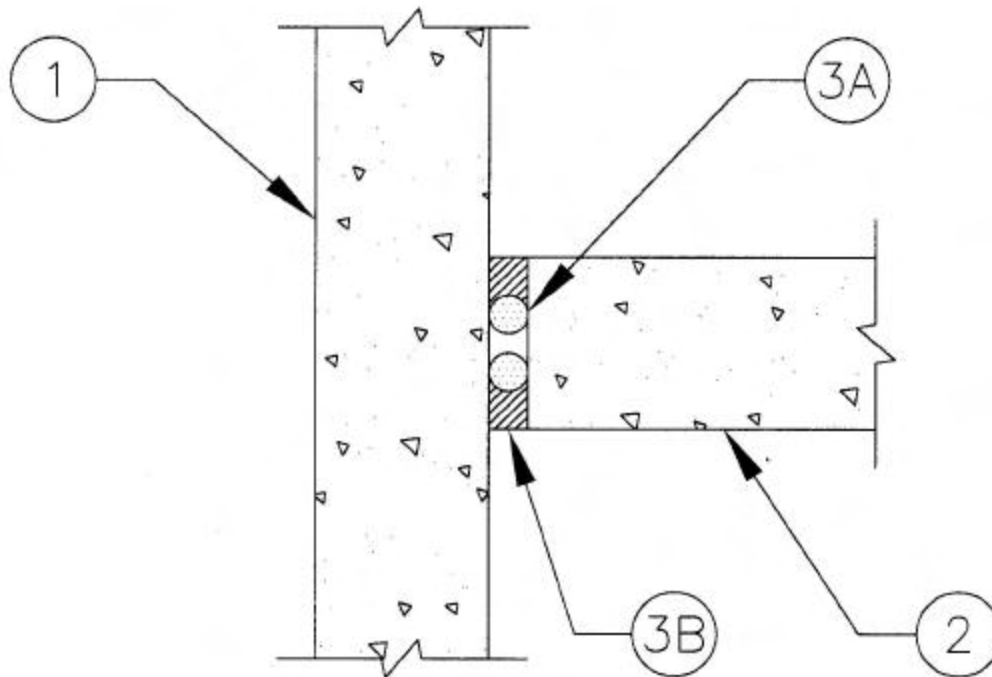

1. **Wall Assembly** – Min 4-1/2 in. thick reinforced lightweight or normal weight (100-150 pcf) structural concrete. Wall may also be constructed of any UL Classified **Concrete Blocks***.
See Classified **Concrete Blocks** (CATZ) category in the Fire resistance Directory for names of manufactures.
2. **Floor Assembly** – Min 4-1/2 in. thick steel-reinforced lightweight or normal weight (100-150 pcf) structural concrete.
3. **Joint Systems** – Max width of joint (at time of installation of joint system) is 1 in. The joint system is designed to accommodate a max 25 percent compression or extension from its installed width. The joint system shall consist of the following:
 - A. **Packing Material – Backer Rod** – Nom 1-1/4 in. diam polyethylene backer rod compressed and firmly packed into joint opening and recessed from both sides of wall to accommodate required thickness of fill material.
 - B. **Fill, Void or Cavity Material – Sealant** – Min 1 in. thickness of fill material applied within the joint, flush with both surfaces of wall.

John Wagner & Associates Inc. – GrabberGard EFC



System No. FW-D-1055

Assembly Rating – 2 Hr

Joint Width – 4 in. Max

Class II Movement Capabilities – 12.5% Compression or Extension

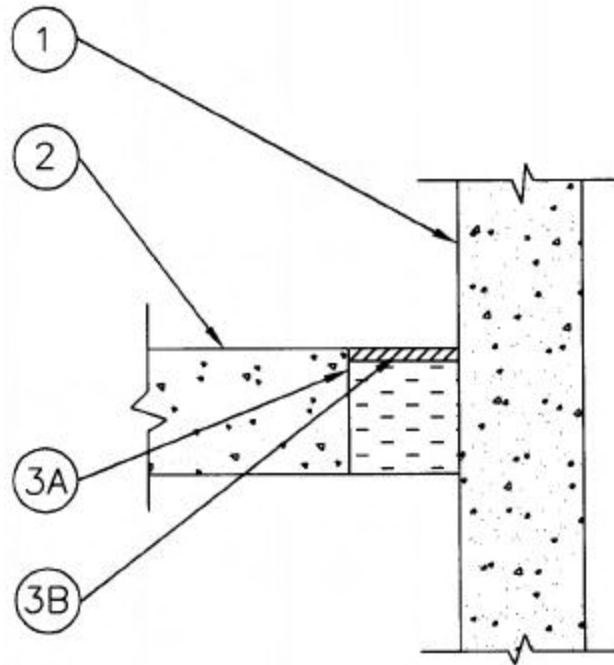

1. **Wall Assembly** – Min 4-1/2 in. thick reinforced lightweight or normal weight (100-150 pcf) structural concrete. Wall may also be constructed of any UL Classified **Concrete Blocks***.

See **Concrete Blocks** (CAZT) category in the Fire Resistance Directory for names of manufacturers.

2. **Floor Assembly** – Min 4-1/2 in. thick steel-reinforced lightweight or normal weight (100-150 pcf) structural concrete.
3. **Joint System** – Max width of joint (at time of installation of joint system) is 4 in. The joint system is designed to accommodate a max 12.5 percent compression or extension from its installed width. The joint system shall consist of the following:
 - A. **Forming Material*** – Min 4 pcf mineral wool batt insulation installed in joint opening as a permanent form. Batt cut to min width of 4-1/2 in. and installed edge first into joint opening, parallel with joint direction, such that batt sections are compressed min 33 percent in thickness and such that the compressed batt sections are flush with the top surface of floor. Adjoining lengths of batt to be tightly butted with seams spaced min 36 in. apart along the length of the joint.
 - Owens Corning** – Paroc Safing Insulation
 - Thermafiber LLC** – Type SAF
 - Rock Wool Manufacturing Company** – Delta Safing Board
 - B. **Fill, Void or Cavity Material* – Sealant** – Min 1/16 in. dry thickness of fill material sprayed or brushed on top surface of floor to completely cover mineral wool and overlap a min of 1/2 in. onto concrete floor.
 - John Wagner & Associates Inc.** – GrabberGard IFC

*Bearing the UL Classification Marking



System No. HW-D-0353
Assembly Ratings 1 & 2 Hr (See Item 2)
Nominal Joint Width – 3/4 in.
Class II Movement Capabilities – 33% Compression or Extension

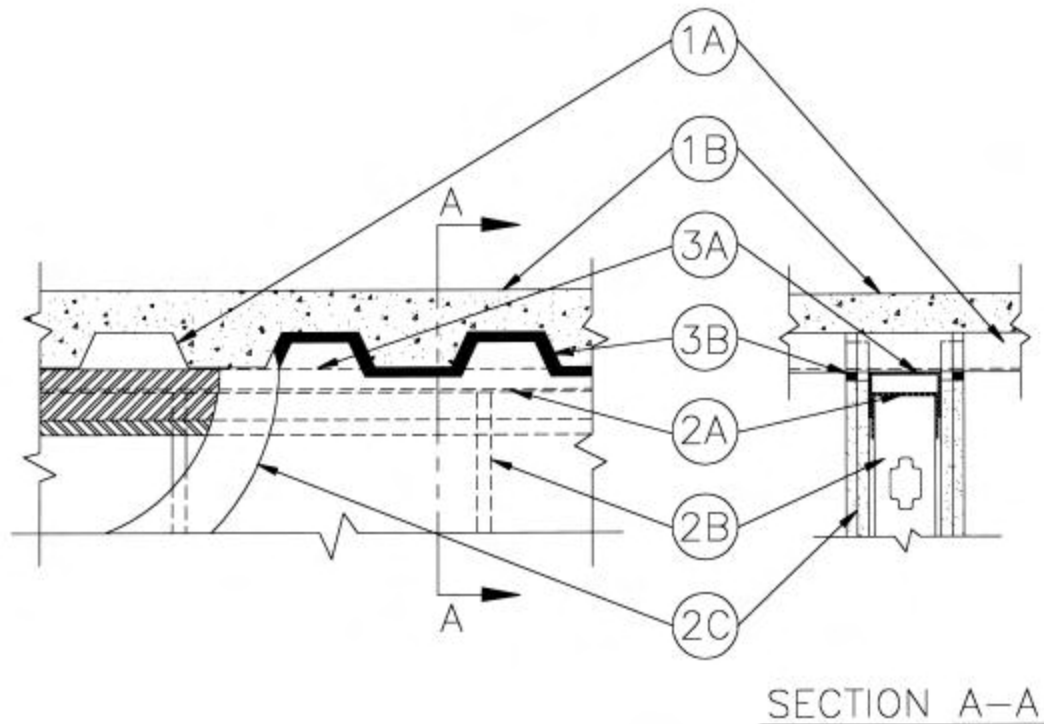

1. **Floor Assembly** – The fluted steel deck/concrete floor assembly shall be constructed of the materials and in the manner described in the individual Floor-Ceiling Design in the UL Fire Resistance Directory and shall include the following construction features:
 - A. **Steel Floor and Form Units*** – Max 3 in. deep galv fluted units.
 - B. **Concrete** – Min 2-1/2 in. thick reinforced concrete, as measured from the top plane of the floor units.
- 1A. **Roof Assembly** (Not Shown) – As an alternative to the floor assembly, a fire-rated fluted steel deck roof assembly may be used. The roof assembly shall be constructed of the materials and in the manner described in the individual P900 Series Roof-Ceiling Design in the UL Fire Resistance Directory. The hourly rating of roof assembly shall be equal or greater than the hourly rating of the wall assembly and shall include the following construction features:
 - A. **Steel Roof Deck** – Max 3 in. deep galv steel fluted roof deck.
 - B. **Roof Insulation** – Min 2-1/4 in. thick poured insulation concrete, as measured from the top plane of the floor units.
 - C. **Roof Covering*** – Hot-mopped or cold-application materials compatible with insulating concrete.
2. **Wall Assembly** – The 1 or 2 hr fire rated gypsum board/steel stud wall assembly shall be constructed of the materials and in the manner described in the individual U400 - Series Wall or Partition Design in the UL Fire Resistance Directory and shall include the following construction features:
 - A. **Steel Floor And Ceiling Runners** – Floor and ceiling runners of wall assembly shall consist of galv steel channels sized to accommodate steel studs (Item 2B). When U-shaped deflection channel (Item 3A) is used, ceiling runner installed within the deflection channel with 1 in. gap maintained between the top of ceiling runner and top of deflection plate. When deflection channel is not used, ceiling runner is secured to valleys of steel floor units (Item 1A) with steel fasteners or by welds spaced max 24 in. OC.
 - A1. **Light Gauge Framing* – Slotted Ceiling Runner** – As an alternate to the ceiling runner in Item 2A, slotted ceiling runner to consist of galv steel channel with slotted flanges sized to accommodate steel studs (Item



HW-D-0353

- 2B). Slotted ceiling runner installed perpendicular to direction of fluted steel floor units and secured to valleys of steel fasteners spaced max 24 in. OC. When slotted ceiling runner is used, deflection channel (Item 3A) shall not be used.
- METAL-LITE INC – The System**
SLIPTRACK SYSTEMS INC. – SLP-TRK
- A2. **Light Gauge Framing* – Clipped Ceiling Runner** – As an alternate to the ceiling runner in Item 2A, 2A1, clipped ceiling runner to consist of galv steel channel with clips preformed in track flanges which positively engage the inside flange of the steel studs (Item 2B). Track sized to accommodate steel studs (Item 2B). Track flanges to be min 2-1/2 in. Clipped ceiling runner installed perpendicular to direction of fluted steel floor units and secured to valleys with steel fasteners spaced 24 in. OC. When clipped ceiling runner is used, deflection channel (Item 3A) shall not be used.
- TOTAL STEEL SOLUTIONS LLC – Snap Trak**
- A3. **Light Gauge Framing* – Vertical Deflection Ceiling Runner** – As an alternate to the ceiling runner in Item 2A, 2A1 or 2A2, vertical deflection ceiling runner to consist of galv steel channel with slotted vertical deflection clips mechanically fastened within runner. Slotted clips, provided with step bushings, for permanent fastening of steel studs. Vertical deflection ceiling runner installed perpendicular to direction of fluted steel floor or roof deck and secured to valleys with steel fasteners spaced max 24 in. OC. When slotted ceiling runner is used, deflection channel (Item 3A) shall not be used.
- THE STEEL NETWORK INC – VertiTack VTD358, VTD400, VTD600 and VTD800**
- B. **Studs** – Steel studs to be min 3-5/8 in. wide. Studs cut 1/2 to 3/4 in. less in length than assembly height. Studs attached to ceiling runner with sheet metal screws a min of 1/2 in. below bottom of deflection channel, when deflection channel is used. When deflection channel is not used, studs shall not be secured to ceiling runner. When slotted ceiling runner (Item 2A1) is used, steel studs secured to slotted ceiling runner with No. 8 by 1/2 in. long wafer head steel screws at mid-height of slot on each side of wall. Stud spacing not to exceed 24 in. OC.
- C. **Gypsum Board*** – Gypsum board sheets to be installed to a min total thickness of 5/8 in or 1-1/4 in. on each side of the wall for a 1 or 2 hr fire rated wall, respectively. Wall to be constructed as specified in the individual Wall and Partition Design in the UL Fire Resistance Directory, except that the gypsum board is cut to fit the contour of the steel floor units with a nom 3/4 in. gap. The screws attaching the gypsum board to studs at the top of the wall shall be located 1 in. below the bottom of the deflection channel, when deflection channel is used. When deflection channel is not used, the screws attaching the gypsum board to studs at the top of the wall shall be located 1 in. below the bottom of the ceiling runner. **The hourly fire rating of the joint system is dependent on the hourly fire rating of the wall.**
3. **Joint System – Max separation between bottom of floor and top of wall is 3/4 in. The joint system is designed to accommodate a max 33 percent compression or extension from its installed width.** The joint system consists of a deflection channel and a fill material, as follows:
- A. **Deflection Channel** – (Optional) – A nom 3-5/8 in. wide by min 2 in. deep min 24 ga. steel U-shaped channel. Deflection channel secured to valleys of steel floor units (Item 1A) with steel fasteners or by welds spaced max 24 in. OC. The ceiling runner (Item 2A) is installed within the deflection channel to maintain a 1 in. gap between the top of the ceiling runner and the top of the deflection channel. The ceiling runner is not fastened to the deflection channel.
- B. **Fill Void or Cavity Material* – Sealant** – Min 5/8 in. thickness of fill material installed on each side of the wall between the top of the gypsum board and all surfaces of the steel floor units, flush with each surface of gypsum board.
- John Wagner & Associates Inc. – GrabberGard IFC**

*Bearing the UL Classification Marking



System No. HW-D-0354
Assembly Rating – 2 Hr (See Item 2)
Nominal Joint Width – 3/4 in.
Class II Movement Capabilities – 33% Compression or Extension

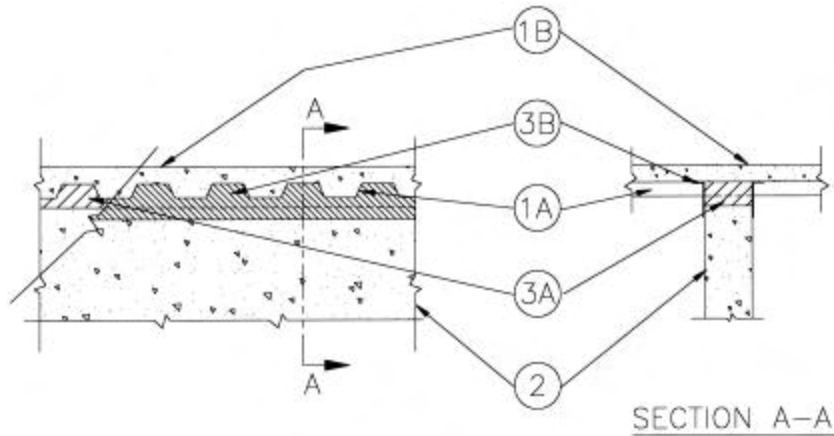

1. **Floor Assembly** – The fluted steel deck/concrete floor assembly shall be constructed of the materials and in the manner described in the individual Floor-Ceiling Design in the UL Fire Resistance Directory and shall include the following construction features:
 - A. **Steel Floor and Form Units*** – Max 3 in. deep galv fluted units.
 - B. **Concrete** – Min 2-1/2 in. thick reinforced concrete, as measured from the top plane of the floor units.
- 1A. **Roof Assembly (Not Shown)** – As an alternative to the floor assembly, a fire-rated fluted steel deck roof assembly may be used. The roof assembly shall be constructed of the materials and in the manner described in the individual P900 Series Roof-Ceiling Design in the UL Fire Resistance Directory. The hourly rating of roof assembly shall be equal or greater than the hourly rating of the wall assembly and shall include the following construction features:
 - A. **Steel Roof Deck** – Max 3 in. deep galv steel fluted roof deck.
 - B. **Roof Insulation** – Min 2-1/4 in. thick poured insulation concrete, as measured from the top plane of the floor units.
 - C. **Roof Covering*** – Hot-mopped or cold-application materials compatible with insulating concrete.
2. **Wall Assembly** – Min 4-7/8 in. thick reinforced lightweight or normal weight (100-150pcf) structural concrete. Wall may also be constructed of any UL Classified **Concrete Blocks***
See **Concrete Blocks (CAZT)** category in the Fire Resistance Directory for names of manufacturers.
3. **Joint System** – Max separation between bottom of floor and top of wall is 3/4 in. The joint system is designed to accommodate a max 33 percent compression or extension from its installed width. The joint system consists of a forming material and a fill material, as follows:
 - A. **Forming Material*** – Min 4-7/8 in. thickness of min 4 pcf density mineral wool batt insulation cut to the shape of the fluted deck, approximately 25 percent larger than the area of the flutes with additional min 4-7/8 in. thick by 1 in. high sections at the bottom of the shapes to completely fill the 3/4 in. gap between the top of the wall and bottom of the steel floor units. Mineral wool to be compressed and firmly packed into the flutes and the gap between the top of the wall and bottom of the steel floor units, flush with both sides of wall.

HIG Minwool LLC – Paroc Safing Insulation
Thermafiber LLC – Type SAF
 - B. **Fill, Void or Cavity Material*** – Min 1/16 in. thickness of fill material sprayed or brushed on each side of the wall in the flutes of the steel floor units and between the top of the wallboard and the bottom of the steel floor units to completely cover mineral wool and overlap a min of 1 in. onto wall and steel deck on both sides of wall.

John Wagner & Associates Inc. – GrabberGard EFS

*Bearing the UL Classification Marking



System No. HW-D-0355
Assembly Ratings – 2 Hr
Nominal Joint Width – 3/4 in.
Class II Movement Capabilities –33% Compression or Extension

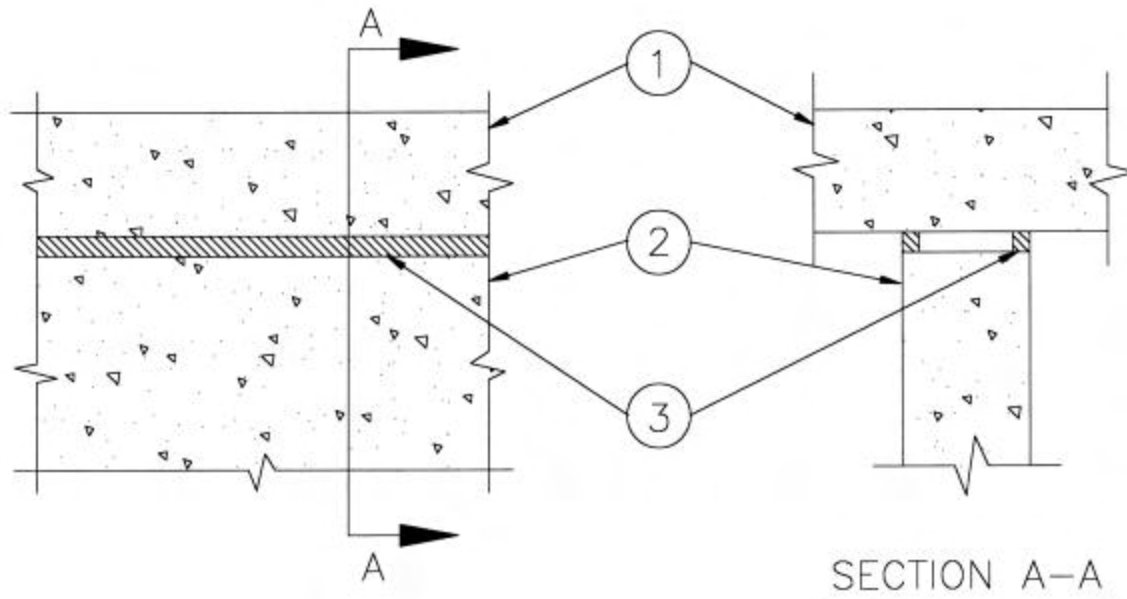

1. **Floor Assembly** – Min 4-1/2 in. thick reinforced lightweight or normal weight (100-150 pcf) concrete.
2. **Wall Assembly** – Min 4-7/8 in. thick reinforced lightweight or normal weight (100-150 pcf) structural concrete. Wall may also be constructed of any UL Classified **Concrete Blocks***. See **Concrete Blocks (CAZT)** category in the Fire Resistance Directory for names of manufacturers.
3. **Joint System** – **Max separation between bottom of floor and top of wall is 3/4 in.** The joint system is designed to accommodate a max 33 percent compression or extension from its installed width. Min 5/8 in. thickness of fill material installed on each side of the wall between the top of the wall and the bottom of the floor, flush with each surface of wall.

John Wagner & Associates Inc. – GrabberGard IFC

*Bearing the UL Classification Marking

System No. HW-D-0356
Assembly Ratings 1 & 2 Hr (See Item 2)
Nominal Joint Width – 3/4 in.
Class II Movement Capabilities – 33% Compression or Extension

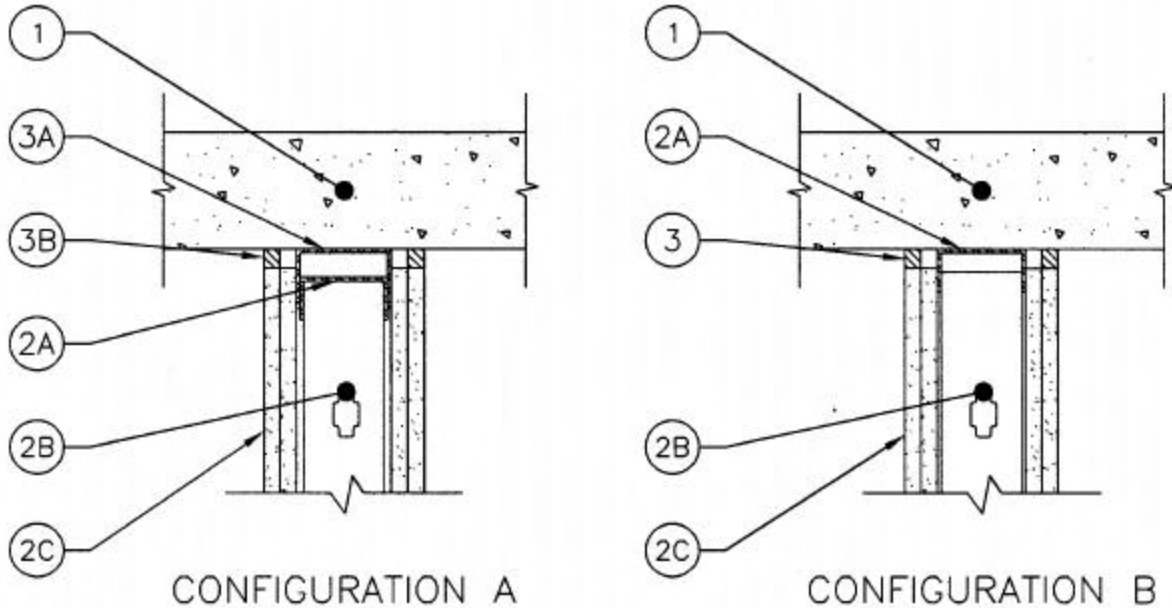

1. **Floor Assembly** – Min 4-1/2 in. thick reinforced lightweight or normal weight (100-150 pcf) concrete.

CONFIGURATION A

2. **Wall Assembly** – The 1 or 2 hr fire rated gypsum wallboard/steel stud wall assembly shall be constructed of the materials and in the manner described in the individual U400 - Series Wall or Partition Design in the UL Fire Resistance Directory and shall include the following construction features:

- A. **Steel Floor and Ceiling Runners** – Floor and Ceiling runners of wall assembly shall consist of galv steel channels sized to accommodate steel studs (Item 2B). Ceiling runner to be installed within the deflection channel such that a 1 in. gap is maintained between the top of ceiling runner and top of deflection channel. Deflection channel is secured to floor with steel masonry anchors spaced a max of 24 in. OC.
- B. **Studs** – Steel studs to be min 3-5/8 in. wide. Studs cut 1/2 to 3/4 in. less in length than assembly height. Studs attached to ceiling runner with sheet metal screws a min of 1/2 in. below bottom of deflection channel. Stud spacing not to exceed 24 in. OC.
- C. **Gypsum Board*** – Gypsum board sheets to be installed to a min total thickness of 5/8 or 1-1/4 in. on each side of the wall for a 1 or 2 hr fire rated assemblies, respectively. Wall to be constructed as specified in the individual Wall and Partition Design in the UL Fire Resistance Directory, except that a nom 3/4 in. gap shall be maintained between the top of the gypsum board and the lower surface of the floor. The screws attaching the wallboard to studs at the top of the wall shall be located 1in. below the bottom of the U-shaped deflection channel (Item 3A).

The hourly fire rating of the joint system is dependent on the hourly fire rating of the wall.

3. **Joint System** – Max separation between bottom of floor and top of wall is 3/4 in. The joint system is designed to accommodate a max 33 percent compression or extension from its installed width. The joint system consists of a deflection channel and a fill material, as follows:

- A. **Deflection Channel** – A nom 3-5/8 in. wide by min 2 in. deep min 24 gauge (or heavier) steel U-shaped channel. Deflection channel secured to floor assembly with steel fasteners, spaced max 24 in. OC. The ceiling runner (Item 2A) is installed within the deflection channel to maintain a 1 in. gap between the top of the ceiling runner and the top of the deflection channel. The ceiling runner is not fastened to the deflection channel.



- B. **Fill, Void or Cavity Material* – Sealant** – Min 5/8 in. thickness of fill material installed on each side of the wall between the top of the gypsum board and the bottom of floor, flush with each surface of wallboard.
John Wagner & Associates Inc. – GrabberGard IFC

CONFIGURATION B

2. **Wall Assembly** – The 1 or 2 hr fire rated gypsum wallboard/steel stud wall assembly shall be constructed of the materials and in the manner described in the individual U400 or V400 - Series Wall or Partition Design in the UL Fire Resistance Directory and shall include the following construction features:
- A. **Steel Floor and Ceiling Runners** – Floor and Ceiling runners of wall assembly shall consist of galv steel channels sized to accommodate steel studs (Item 2B). Ceiling runner is secured to floor with steel masonry anchors spaced a max of 24 in. OC.
 - A1. **Light Gauge Framing* – Slotted Ceiling Runner** – As an alternate to the ceiling runner in Item 2A, slotted ceiling runner to consist of galv steel channel with slotted flanges sized to accommodate steel studs (Item 2B). Slotted ceiling runner is secured to floor with steel masonry anchors spaced max 24 in. OC.
METAL-LITE – The System
SLIPTRACK SYSTEMS, INC – SLP-TRK
 - A2. **Light Gauge Framing* – Clipped Ceiling Runner** – As an alternate to the ceiling runner in Item 2A, 2A1, clipped runner to consist of galv steel channel with clips preformed in track flanges which positively engage the inside flange of the steel studs (Item 2B). Track sized to accommodate steel studs (Item 2B). Track flanges to be min 2-1/2 in. Clipped ceiling runner installed perpendicular to direction of fluted steel floor units and secured to valleys with steel fasteners spaced 24 in. OC.
TOTAL STEEL SOLUTIONS LLC – Snap Trak
 - A3. **Light Gauge Framing* – Vertical Deflection Ceiling Runner** – As an alternate to the ceiling runner in Item 2A, 2A1 or 2A2, vertical deflection ceiling runner to consist of galv steel channel with slotted vertical deflection clips mechanically fastened within runner. Slotted clips, provided with step bushings, for permanent fastening of steel studs. Vertical deflection ceiling runner installed perpendicular to direction of fluted steel floor or roof deck and secured to valleys with steel fasteners spaced max 24 in. OC.
THE STEEL NETWORK INC – VertiTrack VTD358, VTD400, VTD600 and VTD800
 - B. **Studs** – Steel studs to be min 3-5/8 in. wide. Studs cut 1/2 to 3/4 in. less in length than assembly height. Steel studs shall not be secured to ceiling runner when slotted ceiling runner (Item 2A1) is used, steel studs secured to slotted ceiling runner with No. 8 by 1/2 in. long wafer head steel screws at midheight of slot on each side of wall. When vertical deflection ceiling runner (Item 2A3) is used, steel studs secured to slotted vertical deflection clips, through bushings, with steel screws at mid-height of each slot Stud spacing not to exceed 24 in. OC.
 - C. **Gypsum Board*** – Gypsum board sheets to be installed to a min total thickness of 5/8 or 1-1/4 in. on each side of the wall for a 1 or 2 hr fire rated assemblies, respectively. Wall to be constructed as specified in the individual Wall and Partition Design in the UL Fire Resistance Directory, except that a nom 3/4 in. gap shall be maintained between the top of the gypsum board and the lower surface of the floor. The screws attaching the gypsum board to studs at the top of the wall shall be located 1in. below the bottom of the ceiling runner (Item 2A).
The hourly fire rating of the joint system is dependent on the hourly fire rating of the wall.
3. **Fill, Void or Cavity Material* – Sealant** – Max separation between bottom of floor and top of wall is 3/4 in. The joint system is designed to accommodate a max 33 percent compression or extension from its installed width. Min 5/8 in. thickness of fill material installed on each side of the wall between the top of the gypsum board and the bottom of floor, flush with each surface of wallboard.
John Wagner & Associates Inc. – GrabberGard IFC

*Bearing the UL Classification Marking



System No. HW-D-0357

Assembly Ratings 1, 2, 3 and 4 Hr (See Item 2)

L Rating at Ambient – Less than 1 CFM/Lin Ft.

L Rating at 400 F – Less than 1 CFM/Lin Ft.

Nominal Joint Width – 3/4 in.

Class II Movement Capabilities – 33% Compression or Extension

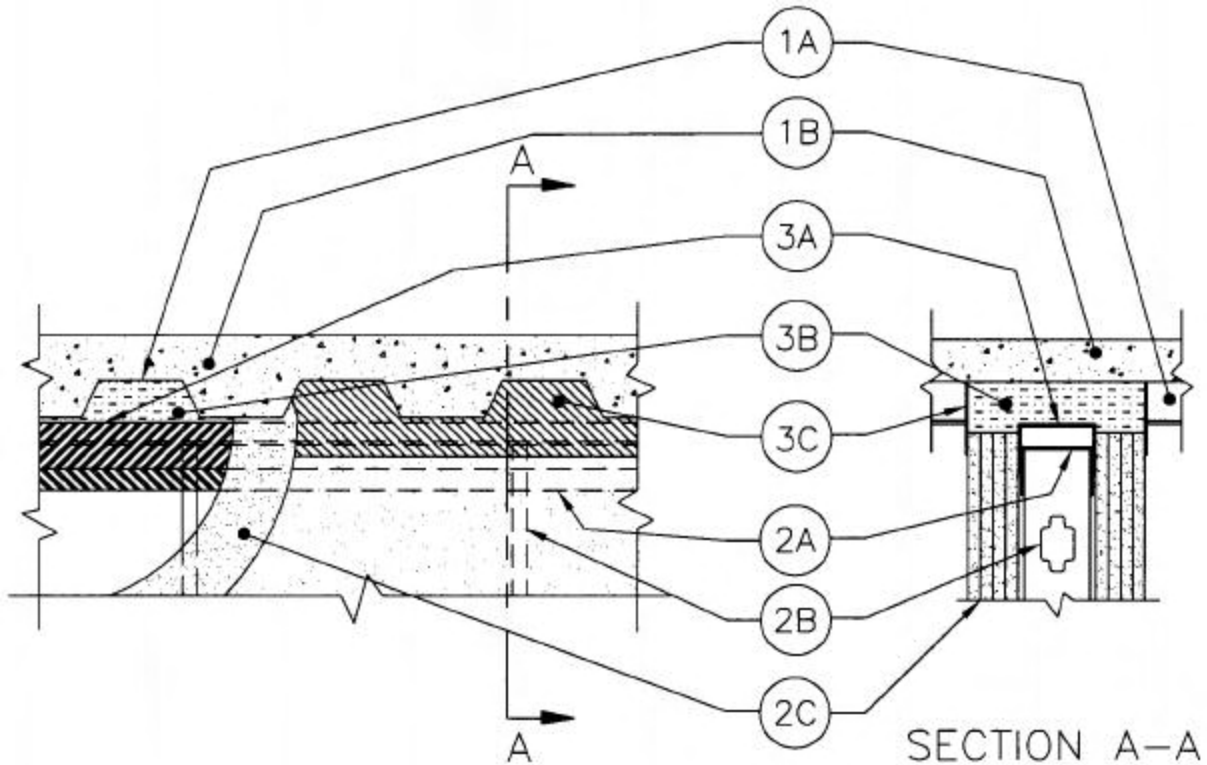

1. **Floor Assembly** – The fluted steel deck/concrete floor assembly shall be constructed of the materials and in the manner described in the individual Floor-Ceiling Design in the UL Fire Resistance Directory and shall include the following construction features:
 - A. **Steel Floor and Form Units*** – Max 3 in. deep galv fluted units.
 - B. **Concrete** – Min 2-1/2 in. thick reinforced concrete, as measured from the top plane of the floor units.
- 1A. **Roof Assembly** (Not Shown) – As an alternative to the floor assembly, a fire-rated fluted steel deck roof assembly may be used. The roof assembly shall be constructed of the materials and in the manner described in the individual P900 Series Roof-Ceiling Design in the UL Fire Resistance Directory. The hourly rating of roof assembly shall be equal or greater than the hourly rating of the wall assembly and shall include the following construction features:
 - A. **Steel Roof Deck** – Max 3 in. deep galv steel fluted roof deck.
 - B. **Roof Insulation** – Min 2-1/4 in. thick poured insulation concrete, as measured from the top plane of the floor units.
 - C. **Roof Covering*** – Hot-mopped or cold-application materials compatible with insulating concrete.



2. **Wall Assembly** – The 1, 2, 3, or 4 hr fire rated gypsum board/steel stud wall assembly shall be constructed of the materials and in the manner described in the individual U400-Series Wall or Partition Design in the UL Fire Resistance Directory and shall include the following construction features:
- A. **Steel Floor and Ceiling Runners** – Floor and ceiling runners of wall assembly shall consist of galv steel channels sized to accommodate steel studs (Item 2B). When U-shaped deflection channel (Item 3A) is used, ceiling runner installed within the deflection channel with 1 in. gap maintained between the top of ceiling runner and top of deflection plate. When deflection channel is not used, ceiling runner is secured to valleys of steel floor units (Item 1A) with steel fasteners or by welds spaced max 24 in. OC.
 - A1. **Light Gauge Framing* – Slotted Ceiling Runner** – As an alternate to the ceiling runner in Item 2A, slotted ceiling runner to consist of galv steel channel with slotted flanges sized to accommodate steel studs (Item 2B). Slotted ceiling runner is secured to floor with steel masonry anchors spaced max 24 in. OC. When slotted ceiling runner is used, deflection channel (Item 3A) shall not be used.

METAL-LITE – The System
SLIPTRACK SYSTEMS, INC – SLP-TRK
 - A2. **Light Gauge Framing* – Clipped Ceiling Runner** – As an alternate to the ceiling runner in Item 2A, 2A1, clipped runner to consist of galv steel channel with clips preformed in track flanges which positively engage the inside flange of the steel studs (Item 2B). Track sized to accommodate steel studs (Item 2B). Track flanges to be min 2-1/2 in. Clipped ceiling runner installed perpendicular to direction of fluted steel floor units and secured to valleys with steel fasteners spaced 24 in. OC. When clipped ceiling runner is used, deflection channel (Item 3A) shall not be used.

TOTAL STEEL SOLUTIONS LLC – Snap Trak
 - A3. **Light Gauge Framing* – Vertical Deflection Ceiling Runner** – As an alternate to the ceiling runner in Item 2A, 2A1 or 2A2, vertical deflection ceiling runner to consist of galv steel channel with slotted vertical deflection clips mechanically fastened within runner. Slotted clips, provided with step bushings, for permanent fastening of steel studs. Vertical deflection ceiling runner installed perpendicular to direction of fluted steel floor or roof deck and secured to valleys with steel fasteners spaced max 24 in. OC. When slotted ceiling runner is used, deflection channel (Item 3A) shall not be used.

THE STEEL NETWORK INC – VertiTrack VTD358, VTD400, VTD600 and VTD800
 - B. **Studs** – Steel studs to be min 3-5/8 in. wide. Studs cut 1/2 to 3/4 in. less in length than assembly height. Studs attached to ceiling runner with sheet metal screws a min of 1/2 in. below bottom of deflection channel, when deflection channel is used. When deflection channel is not used, studs shall not be secured to ceiling runner. When slotted ceiling runner (Item 2A1) is used, steel studs secured to slotted ceiling runner with No. 8 by 1/2 in. long wafer head steel screws at midheight of slot on each side of wall. When vertical deflection ceiling runner (Item 2A3) is used, steel studs secured to slotted vertical deflection clips, through bushings, with steel screws at mid-height of each slot Stud spacing not to exceed 24 in. OC
 - C. **Gypsum Board*** – Gypsum board sheets installed to a min total thickness of 5/8, 1-1/4, 1-7/8 or 2-1/2 in. on each side of wall for 1, 2, 3 and 4 hr rated assemblies, respectively. Wall to be constructed as specified in the individual Wall and Partition Design in the UL Fire Resistance Directory, except that a nom 3/4 in. gap shall be maintained between the top of the gypsum board and the lower surface of the floor. The screws attaching the gypsum board to studs at the top of the wall shall be located 1 in. below the bottom of the deflection channel, when deflection channel is used. When deflection channel is not used, the screws attaching the gypsum board to studs at the top of the wall shall be located 1 in. below the bottom of the ceiling runner. **The hourly fire rating of the joint system is dependent on the hourly fire rating of the wall.**



HW-D-0357

3. **Joint System – Max separation between bottom of floor and top of wall is 3/4 in. The joint system is designed to accommodate a max 33 percent compression or extension from its installed width.** The joint system consists of a deflection channel, forming material and a fill material, as follows:
- A. **Deflection Channel** (Optional) – A nom 3-5/8 in. wide by min 2 in. deep, min 24 ga. steel U-shaped channel. Deflection channel secured to valleys of steel floor units (Item 1A) with steel fasteners or by welds spaced max 24 in. OC. The ceiling runner (Item 2A) is installed within the deflection channel to maintain a 1 in. gap between the top of the ceiling runner and the top of the deflection channel. The ceiling runner is not fastened to the deflection channel.
 - B. **Forming Material*** – Min 4-7/8 in. thickness of min 4 pcf density mineral wool batt insulation for 1 and 2 hr rated assemblies, min 7-3/8 in. and 8-5/8 in. thickness of min 4 pcf density mineral wool batt insulation for 3 and 4 hr rated assemblies, respectively, cut to the shape of the fluted deck, approximately 25 percent larger than the area of the flutes and compressed into flutes of the steel floor units between the top of the deflection channel and the steel deck, flush with both sides of wall. Additional pieces of min 5/8 in. thickness of min 4 pcf mineral wool batt insulation for 1 and 2 hr rated assemblies, min 1-7/8 in. and min 2-1/2 in. thickness of min 4 pcf density mineral wool batt insulation for 3 and 4 hr rated assemblies, respectively, cut into strips and compressed approximately 25 percent to fill the 3/4 in. gap between the top of the gypsum board and bottom of the steel floor units, flush with both sides of wall.
 - IIG Minwool LLC** - Paroc Safing Insulation
 - Thermafiber L L C** - Type SAF
 - Rock Wool Manufacturing Company** – Delta Safing Board
 - C. **Fill, Void or Cavity Material*** – Min 1/16 in. (dry) thickness of fill material sprayed or brushed on each side of the wall in the flutes of the steel floor units and between the top of the gypsum board and the bottom of the steel floor units to completely cover mineral wool and overlap a min of 1 in. onto gypsum board and steel deck, on both sides of wall.
 - John Wagner & Associates Inc.** – GrabberGard EFS

*Bearing the UL Classification Marking



System No. HW-D-0358

Assembly Ratings – 1 & 2 Hr

Nominal Joint Width – 1 in.

CLASS II Movement Capabilities – 25% Compression or Extension

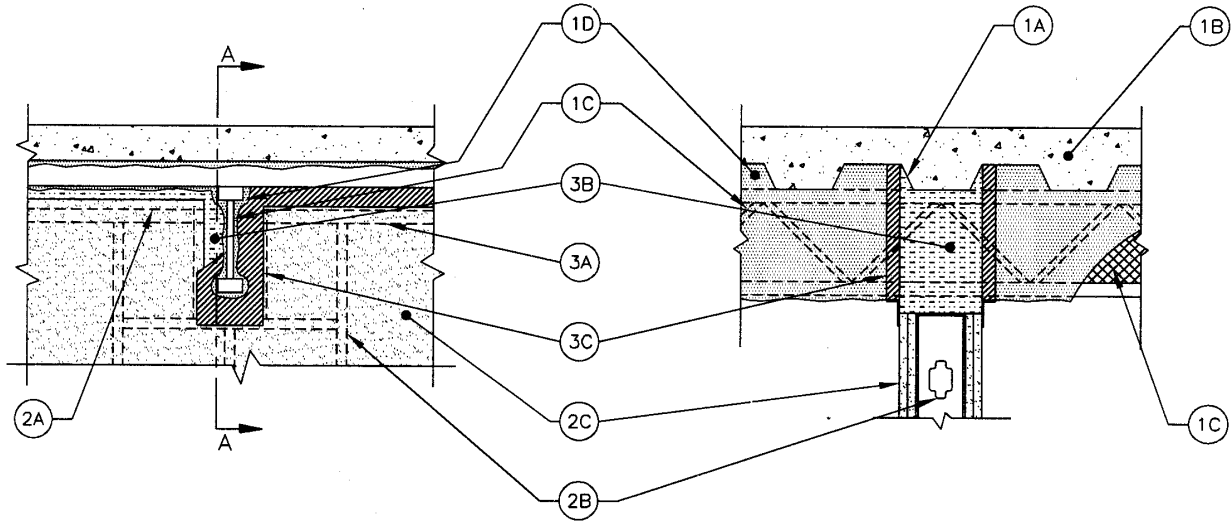

1. **Floor Assembly** – The fire-rated fluted steel deck/concrete floor assembly shall be constructed of the materials and in the manner described in the individual D700 Series Floor -Ceiling Design in the UL Fire Resistance Directory and shall include the following construction features:
 - A. **Steel Floor and Form Units*** – Max 3 in. deep galv steel fluted floor units.
 - B. **Concrete** – Min 2-1/2 in. thick reinforced lightweight or normal weight (100-150 pcf) concrete, as measured from the top plane of the floor units.
 - C. **Structural Steel Support** (Optional) – Steel beam or open-web steel joist, as specified in the individual D700 Series Floor-Ceiling Design, used to support steel floor units. Structural steel support oriented perpendicular to wall assembly. Where open-web steel joists pass through the fire rated wall, 3/8 in. diamond mesh expanded steel lath having a nom weight of 1.7 to 3.4 lb per sq yd shall be secured to one side of each joist with galvanized steel tie wire and the lath shall be fully covered with spray-applied fire resistive material with no min thickness requirement.
 - D. **Spray-Applied Fire Resistive Materials*** – After installation of the ceiling runner (Item 2A) or deflection channel (Item 3A, if used), steel floor units and structural steel supports to be sprayed in accordance with the specifications in the individual D700 Series Design.

WR Grace & Co. Conn Construction Products Div. – Type MK-6/HY.

2. **Wall Assembly** – The 1 or 2 hr fire rated gypsum board/steel stud wall assembly shall be constructed of the materials and in the manner described in the individual U400 - Series Wall or Partition Design in the UL Fire Resistance Directory and shall include the following construction features:
 - A. **Steel Floor and Ceiling Runners** – Floor and ceiling runners of wall assembly shall consist of galv steel channels sized to accommodate steel studs (Item 2B). Ceiling runner to be provided with min 1-1/4 in. to max 3 in. flanges. When deflection channel (Item 3A) is used, ceiling runner is to nest within the deflection channel with 1/2 in. to 1 in. gap maintained between the top of ceiling runner and top of the deflection channel. When deflection channel is not used, ceiling runner to be provided with 3 in. flanges and secured to steel floor units (Item 1A) with steel fasteners or by welds spaced max 24 in. OC. Ceiling runner to be centered beneath and parallel with valley of steel floor units. A clearance of 1 to 1-1/4 in. shall be maintained between the end of the ceiling runner or deflection channel and the spray applied fire resistive material on the structural steel support members.



- A1. **Light Gauge Framing* – Slotted Ceiling Runner** – As an alternate to the ceiling runner in Item 2A, slotted ceiling runner to consist of galv steel channel with slotted flanges sized to accommodate steel studs (Item 2B). Slotted ceiling runner installed perpendicular to direction of fluted steel floor units and secured to valleys with steel fasteners spaced max 24 in. OC. When slotted ceiling runner is used, deflection channel (Item 3A) shall not be used.

METAL-LITE – The System

SLIPTRACK SYSTEMS, INC – SLP-TRK

- A2. **Light Gauge Framing* – Clipped Ceiling Runner** – As an alternate to the ceiling runner in Item 2A, 2A1, clipped runner to consist of galv steel channel with clips preformed in track flanges which positively engage the inside flange of the steel studs (Item 2B). Track sized to accommodate steel studs (Item 2B). Track flanges to be min 2-1/2 in. Clipped ceiling runner installed perpendicular to direction of fluted steel floor units and secured to valleys with steel fasteners spaced 24 in. OC. When clipped ceiling runner is used, deflection channel (Item 3A) shall not be used.

TOTAL STEEL SOLUTIONS LLC – Snap Trak

- A3. **Light Gauge Framing* – Vertical Deflection Ceiling Runner** – As an alternate to the ceiling runner in Item 2A, 2A1 or 2A2, vertical deflection ceiling runner to consist of galv steel channel with slotted vertical deflection clips mechanically fastened within runner. Slotted clips, provided with step bushings, for permanent fastening of steel studs. Vertical deflection ceiling runner installed perpendicular to direction of fluted steel floor or roof deck and secured to valleys with steel fasteners spaced max 24 in. OC. When slotted ceiling runner is used, deflection channel (Item 3A) shall not be used.

THE STEEL NETWORK INC – VertiTrack VTD358, VTD400, VTD600 and VTD800

- B. **Studs** – Steel studs to be min 3-5/8 in. wide. Studs cut 1/2 to 3/4 in. less in length than with bottom nesting in and secured to floor runner. When deflection channel (Item 3A) is used, steel studs attached to ceiling runner (Item 2A) with sheet metal screws located 1/2 in. below bottom of deflection channel. When deflection channel is not used, studs to nest in ceiling runner without attachment. When slotted ceiling runner (Item 2A1) is used, steel studs secured to slotted ceiling runner with No. 8 by 1/2 in. long wafer head steel screws at midheight of slot on each side of wall. When vertical deflection ceiling runner (Item 2A3) is used, steel studs secured to slotted vertical deflection clips, through bushings, with steel screws at mid-height of each slot. A framed opening shall be constructed around each structural steel support member. A min clearance of 1 in. to a max clearance of 3 in. shall be maintained between the framing and spray applied fire resistive material on the two sides of the structural support member. The clearance between the framing and the spray applied fire resistive material on the bottom of the structural steel support member shall be min 1/2 in. to max 1 in. Stud spacing not to exceed 24 in. OC

- C. **Gypsum Board*** – Gypsum Wallboard sheets installed to a min total thickness of 5/8 in. and 1-1/4 in. on each side of wall for 1 and 2 hr rated assemblies, respectively. Wall to be constructed as specified in the individual U400 Series Design in the UL Fire Resistance Directory, except that a max nom 1 in. gap shall be maintained between the top of the gypsum board and the spray applied fire resistive material on the steel floor units and min 1/2 in. to max 1 in. gap shall be maintained between the top edge of the gypsum board and the spray applied fire resistive material on the structural steel support member. The screws attaching the gypsum board to the studs along the top of the wall shall be located 1 in. below the bottom of the deflection channel, when deflection channel is used. When deflection channel is not used, the screws attaching the gypsum board at the top of the wall shall be located 1 in. below the bottom of the ceiling runner. **The hourly fire rating of the joint system is equal to the hourly fire rating of the wall.**



3. **Joint System – Max separation between bottom of the spray applied fire resistive material on the steel floor units and top of gypsum board (at time of installation of joint system) is 1 in. Max separation between spray applied fire resistive material on bottom of structural support member and framed opening in top of wall is 1 in. The joint system is designed to accommodate a max 25 percent compression or extension from its installed width as measured between the spray applied fire resistive material on the steel floor units and the top of the gypsum board.** The joint system consists of a forming material and fill materials, with or without deflection channel (Item 3A), as follows:
- A. **Deflection Channel (Optional)** – Min 24 gauge galv steel channel, 3 in. deep, sized to accommodate ceiling runner (Item 2A). Deflection channel to be centered beneath and parallel with valley of steel floor unit and secured to steel floor unit with steel fasteners or by welds spaced max 24 in. OC. The ceiling runner (Item 2A) is installed within the deflection channel to maintain a 1/2 in. to 1 in. gap between the top of the ceiling runner and the top of the deflection channel. A clearance of 1 to 1-1/4 in. shall be maintained between the end of the deflection channel and the spray applied fire resistive material on the structural steel support members. The ceiling runner nest inside the deflection channel without attachment.
 - B. **Forming Material** – Min 4 pcf density mineral wool batt insulation cut to a length approximately the same as the overall thickness of wall and inserted cut edge first into the spaces between the spray-applied fire resistive material on the structural steel member and the framed notch at the top of the wall, flush with the gypsum board surface on both sides of the wall. The thickness of forming material shall be sufficient to attain a min compression of 33 percent between the sides of the framed notch and the protected structural steel member and between the bottom of the framed notch and bottom of the protected structural steel member. Additional sections of mineral wool batt insulation are compressed 33 percent in thickness and are installed cut edge first to completely fill the gap above the top of the gypsum board, flush with both surfaces of wall.
 - Fibrex Insulations Inc.** – FBX Safing Insulation
 - IIG Minwool LLC** – Paroc Safing Insulation
 - Rock Wool Manufacturing Co.** – Delta Board
 - Roxul** – Type Safe
 - Thermafiber, LLC** – Type SAF
 - C. **Fill, Void or Cavity Material*** – Min 1/16 in. wet thickness of fill material sprayed or brushed over the forming material on each side of the wall. Fill material to overlap a min of 1 in. onto gypsum board and a min 2 in. onto the spray applied fire resistive material (Item 1D) on the steel floor unit and on the structural steel support member on both sides of wall.
 - John Wagner & Associates Inc.** – GrabberGard EFS

*Bearing the UL Classification Marking



System No. HW-D-0359

Assembly Rating 2 Hr

L Rating at Ambient – Less than 1 CFM/Lin. Ft.

L Rating at 400° F – Less than 1 CFM/Lin. Ft.

Nominal Joint Width - 1”

Class II Movement Capabilities – 25% Compression or Extension

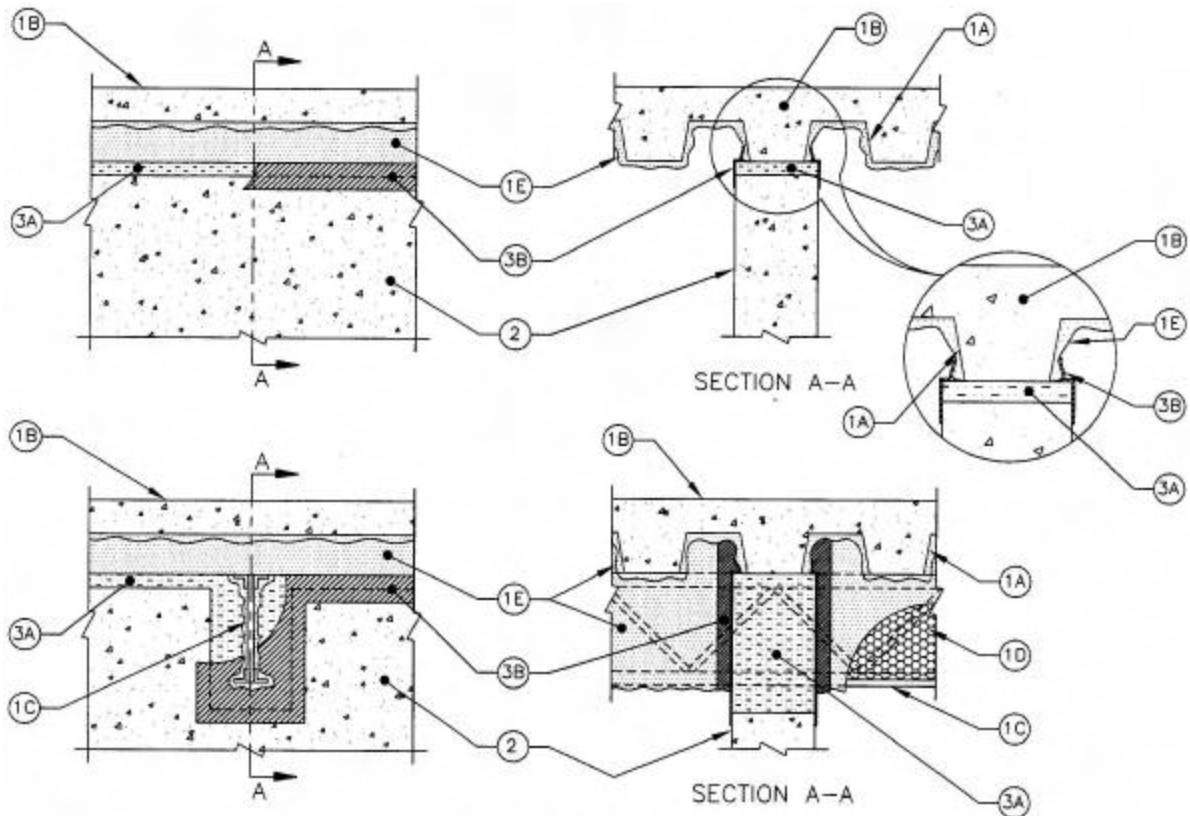

1. **Floor Assembly** – The fire-rated fluted steel deck/concrete floor assembly shall be constructed of the materials and in the manner described in the individual D700 Series Floor -Ceiling Design in the UL Fire Resistance Directory and shall include the following construction features:
 - A. **Steel Floor and Form Units*** – Max 3 in. deep galv steel fluted floor units.
 - B. **Concrete** - Min 2-1/2 in. thick reinforced concrete, as measured from the top plane of the floor units.
 - C. **Structural Steel Support** (Optional) – Steel beam or open-web steel joist, as specified in the individual D700 Series Floor-Ceiling Design, used to support steel floor units. Structural steel support oriented perpendicular to wall assembly.
 - D. **Steel Lath** – Where open-web steel joists pass through the fire rated wall, 3/8 in. diamond mesh expanded steel lath having a nom weight of 1.7 to 3.4 lb per sq yd shall be secured to one side of each joist with steel tie wire and the lath shall be fully covered with spray-applied fire resistive material with no min thickness requirement.
 - E. **Spray-Applied Fire Resistive Materials*** – Prior to installation of the forming material (Item 3A) and sealant (Item 3B), steel floor units and structural steel supports to be sprayed with the thickness of material specified in the individual D700 Series Design. Material is to be excluded from the steel deck in the area immediately above the wall. The spray applied fire resistive material is mixed with water in accordance with the mixing instructions on the bag. The min average density of the spray applied fire resistive material shall be 15 pcf with a min individual density of 14 pcf. See Design Information Section in Volume 1 of the Fire Resistance Directory for method of density determination.

WR Grace & Co. Conn Construction Products Div. – Type MK-6/HY.



HW-D-0359

2. **Wall Assembly** – Min 6-1/8 in. thick reinforced lightweight or normal weight (100-150 pcf) concrete. Wall may also be constructed of any UL Classified Concrete Block*. Wall assembly to be centered beneath and parallel with valley of steel floor unit.

See **Concrete Block** (CAZT) category in Fire Resistance Directory for names of manufacturers.

3. **Joint System** – Max separation between bottom plane of steel floor unit and top of concrete wall (at time of installation of joint system) is 1 in. Max separation between spray applied fire resistive material on bottom of structural support member and notched opening in top of wall is 1 in. Max clearance between spray applied fire resistive material on sides of structural steel member and notched opening in top of wall is 3 in. The joint system is designed to accommodate a max 25 percent compression or extension from its installed width as measured between bottom plane of steel floor units and top of concrete wall. The joint system shall consist of forming and fill materials, as follows:

- A. **Forming Material*** – Nom 4 pcf density mineral wool batt insulation cut to a length approximately 1 in. longer than overall thickness of wall and inserted cut edge first into the spaces between the spray-applied fire resistive material on the structural steel member and the notched opening at the top of the wall. The thickness of forming material shall be sufficient to attain a min compression of 20 percent between the sides of the notched opening and the protected structural steel member and a min compression of 33 percent between the bottom of the notched opening and the bottom of the protected structural steel member. The mineral wool batt insulation is to be additionally compressed in the length direction such that it is flush with both surfaces of the wall. Additional min 8 in. wide sections of mineral wool batt insulation are compressed 50 percent in thickness and are installed cut edge first to completely fill the gap above the top of the wall. The forming material shall be flush with both surfaces of wall.

Fibrex Insulations Inc. – FBX Safing Insulation

IIG Minwool LLC – Paroc Safing Insulation

Rock Wool Manufacturing Co. – Delta Board or Delta-8

Roxul – Type Safe

Thermafiber, LLC – Type SAF

- B. **Fill, Void or Cavity Material*** – Min 1/8 in. (dry) thickness of fill material sprayed or brushed over the forming material on each side of the wall. Fill material to overlap a min of 1/2 in. onto the concrete wall and a min 2 in. onto the spray applied fire resistive material (Item 1E) on the steel floor unit and on the structural steel support member on both sides of wall.

John Wagner & Associates Inc. – GrabberGard EFS

*Bearing the UL Classification Marking



System No. HW-D-0368
Assembly Ratings 1 & 2 Hr (See Item 2)
Nominal Joint Width – 3/4 in.
Class II Movement Capabilities – 33% Compression or Extension

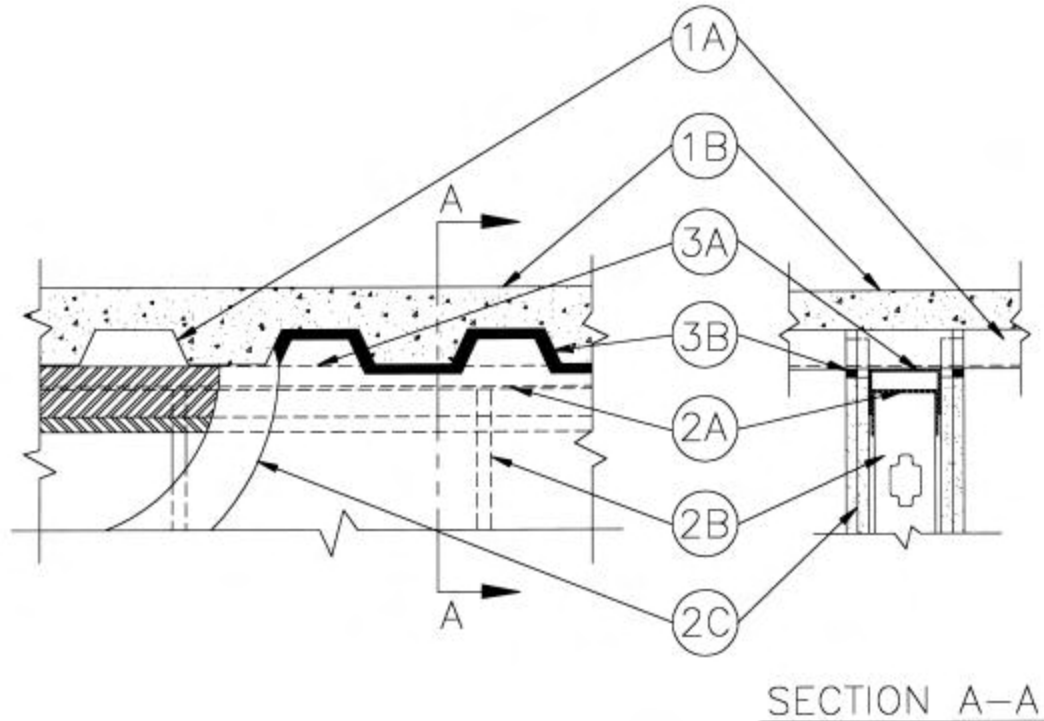

1. **Floor Assembly** – The fluted steel deck/concrete floor assembly shall be constructed of the materials and in the manner described in the individual Floor-Ceiling Design in the UL Fire Resistance Directory and shall include the following construction features:
 - A. **Steel Floor and Form Units*** – Max 3 in. deep galv fluted units.
 - B. **Concrete** – Min 2-1/2 in. thick reinforced concrete, as measured from the top plane of the floor units.
- 1A. **Roof Assembly** (Not Shown) – As an alternative to the floor assembly, a fire-rated fluted steel deck roof assembly may be used. The roof assembly shall be constructed of the materials and in the manner described in the individual P900 Series Roof-Ceiling Design in the UL Fire Resistance Directory. The hourly rating of roof assembly shall be equal or greater than the hourly rating of the wall assembly and shall include the following construction features:
 - A. **Steel Roof Deck** – Max 3 in. deep galv steel fluted roof deck.
 - B. **Roof Insulation** – Min 2-1/4 in. thick poured insulation concrete, as measured from the top plane of the floor units.
 - C. **Roof Covering*** – Hot-mopped or cold-application materials compatible with insulating concrete.
2. **Wall Assembly** – The 1 or 2 hr fire rated gypsum board/steel stud wall assembly shall be constructed of the materials and in the manner described in the individual U400 - Series Wall or Partition Design in the UL Fire Resistance Directory and shall include the following construction features:
 - A. **Steel Floor And Ceiling Runners** – Floor and ceiling runners of wall assembly shall consist of galv steel channels sized to accommodate steel studs (Item 2B). When U-shaped deflection channel (Item 3A) is used, ceiling runner installed within the deflection channel with 1 in. gap maintained between the top of ceiling runner and top of deflection plate. When deflection channel is not used, ceiling runner is secured to valleys of steel floor units (Item 1A) with steel fasteners or by welds spaced max 24 in. OC.
 - A1. **Light Gauge Framing*** – **Slotted Ceiling Runner** – As an alternate to the ceiling runner in Item 2A, slotted ceiling runner to consist of galv steel channel with slotted flanges sized to accommodate steel studs (Item 2B). Slotted ceiling runner installed perpendicular to direction of fluted steel floor units and secured to



valleys of steel fasteners spaced max 24 in. OC. When slotted ceiling runner is used, deflection channel (Item 3A) shall not be used.

METAL-LITE INC – The System
SLIPTRACK SYSTEMS INC. – SLP-TRK

- A2. **Light Gauge Framing* – Clipped Ceiling Runner** – As an alternate to the ceiling runner in Item 2A, 2A1, clipped ceiling runner to consist of galv steel channel with clips preformed in track flanges which positively engage the inside flange of the steel studs (Item 2B). Track sized to accommodate steel studs (Item 2B). Track flanges to be min 2-1/2 in. Clipped ceiling runner installed perpendicular to direction of fluted steel floor units and secured to valleys with steel fasteners spaced 24 in. OC. When clipped ceiling runner is used, deflection channel (Item 3A) shall not be used.

TOTAL STEEL SOLUTIONS LLC – Snap Trak

- A3. **Light Gauge Framing* – Vertical Deflection Ceiling Runner** – As an alternate to the ceiling runner in Item 2A, 2A1 or 2A2, vertical deflection ceiling runner to consist of galv steel channel with slotted vertical deflection clips mechanically fastened within runner. Slotted clips, provided with step bushings, for permanent fastening of steel studs. Vertical deflection ceiling runner installed perpendicular to direction of fluted steel floor or roof deck and secured to valleys with steel fasteners spaced max 24 in. OC. When slotted ceiling runner is used, deflection channel (Item 3A) shall not be used.

THE STEEL NETWORK INC – VertTrack VTD358, VTD400, VTD600 and VTD800

- B. **Studs** – Steel studs to be min 3-5/8 in. wide. Studs cut 1/2 to 3/4 in. less in length than assembly height. Studs attached to ceiling runner with sheet metal screws a min of 1/2 in. below bottom of deflection channel, when deflection channel is used. When deflection channel is not used, studs shall not be secured to ceiling runner. When slotted ceiling runner (Item 2A1) is used, steel studs secured to slotted ceiling runner with No. 8 by 1/2 in. long wafer head steel screws at mid-height of slot on each side of wall. Stud spacing not to exceed 24 in. OC.
- C. **Gypsum Board*** – Gypsum board sheets to be installed to a min total thickness of 5/8 in or 1-1/4 in. on each side of the wall for a 1 or 2 hr fire rated wall, respectively. Wall to be constructed as specified in the individual Wall and Partition Design in the UL Fire Resistance Directory, except that the gypsum board is cut to fit the contour of the steel floor units with a nom 3/4 in. gap. The screws attaching the gypsum board to studs at the top of the wall shall be located 1 in. below the bottom of the deflection channel, when deflection channel is used. When deflection channel is not used, the screws attaching the gypsum board to studs at the top of the wall shall be located 1 in. below the bottom of the ceiling runner. **The hourly fire rating of the joint system is dependent on the hourly fire rating of the wall.**

3. **Joint System – Max separation between bottom of floor and top of wall is 3/4 in. The joint system is designed to accommodate a max 33 percent compression or extension from its installed width.** The joint system consists of a deflection channel and a fill material, as follows:

- A. **Deflection Channel** – (Optional) – A nom 3-5/8 in. wide by min 2 in. deep min 24 ga. steel U-shaped channel. Deflection channel secured to valleys of steel floor units (Item 1A) with steel fasteners or by welds spaced max 24 in. OC. The ceiling runner (Item 2A) is installed within the deflection channel to maintain a 1 in. gap between the top of the ceiling runner and the top of the deflection channel. The ceiling runner is not fastened to the deflection channel.

- B. **Fill Void or Cavity Material* – Sealant** – Min 5/8 in. thickness of fill material installed on each side of the wall between the top of the gypsum board and all surfaces of the steel floor units, flush with each surface of gypsum board.

John Wagner & Associates Inc. – GrabberGard EFC

*Bearing the UL Classification Marking



System No. HW-D-0369

Assembly Ratings – 2 Hr

Nominal Joint Width – 3/4 in.

Class II Movement Capabilities – 33% Compression or Extension

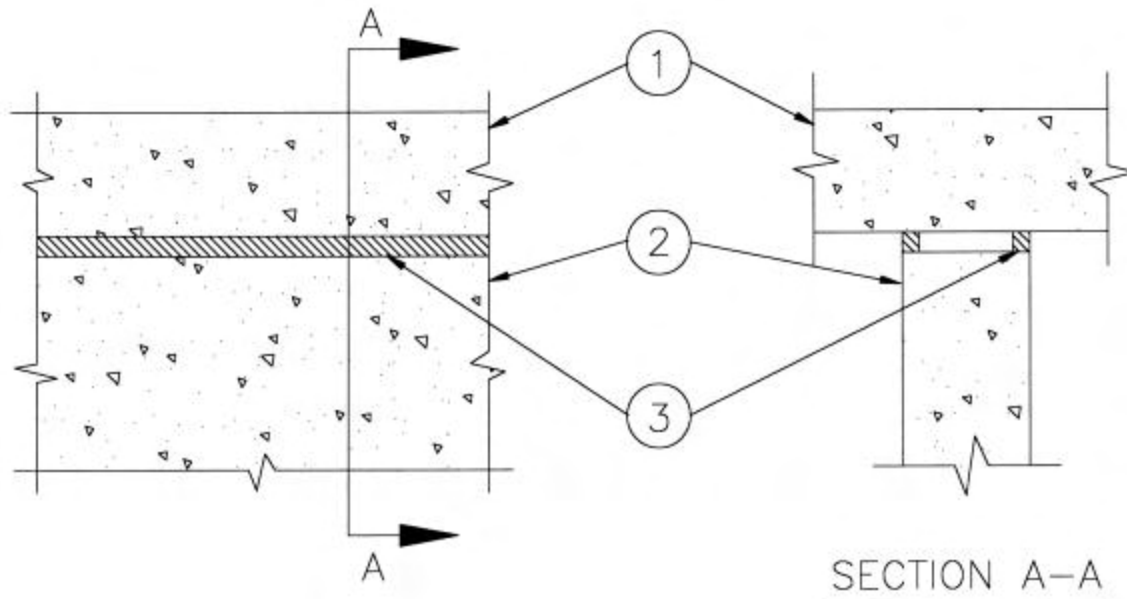

1. **Floor Assembly** – Min 4-1/2 in. thick reinforced lightweight or normal weight (100-150 pcf) concrete.
2. **Wall Assembly** – Min 4-7/8 in. thick reinforced lightweight or normal weight (100-150 pcf) structural concrete. Wall may also be constructed of any UL Classified **Concrete Blocks***. See **Concrete Blocks** (CAZT) category in the Fire Resistance Directory for names of manufacturers.
3. **Joint System** – **Max separation between bottom of floor and top of wall is 3/4 in. The joint system is designed to accommodate a max 33 percent compression or extension from its installed width.** Min 5/8 in. thickness of fill material installed on each side of the wall between the top of the wall and the bottom of the floor, flush with each surface of wall.

John Wagner & Associates Inc. – GrabberGard EFC

*Bearing the UL Classification Marking



System No. HW-D-0370
Assembly Ratings 1 & 2 Hr (See Item 2)
Nominal Joint Width – 3/4 in.
Class II Movement Capabilities – 33% Compression or Extension

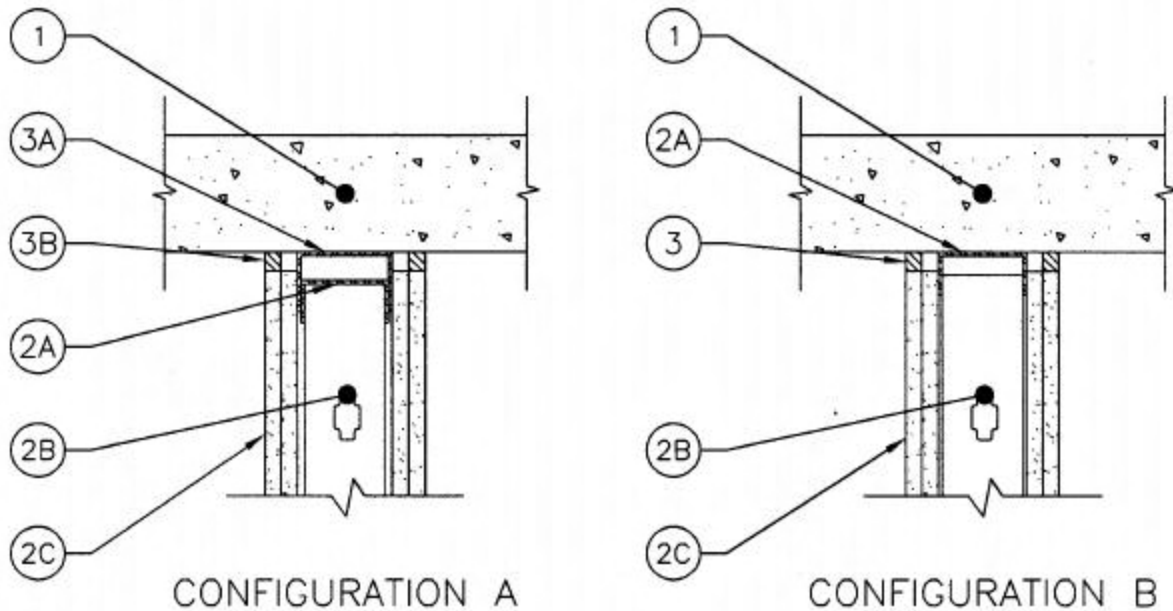

1. **Floor Assembly** – Min 4-1/2 in. thick reinforced lightweight or normal weight (100-150 pcf) concrete.

CONFIGURATION A

2. **Wall Assembly** – The 1 or 2 hr fire rated gypsum wallboard/steel stud wall assembly shall be constructed of the materials and in the manner described in the individual U400 - Series Wall or Partition Design in the UL Fire Resistance Directory and shall include the following construction features:
 - A. **Steel Floor and Ceiling Runners** – Floor and Ceiling runners of wall assembly shall consist of galv steel channels sized to accommodate steel studs (Item 2B). Ceiling runner to be installed within the deflection channel such that a 1 in. gap is maintained between the top of ceiling runner and top of deflection channel. Deflection channel is secured to floor with steel masonry anchors spaced a max of 24 in. OC.
 - B. **Studs** – Steel studs to be min 3-5/8 in. wide. Studs cut 1/2 to 3/4 in. less in length than assembly height. Studs attached to ceiling runner with sheet metal screws a min of 1/2 in. below bottom of deflection channel. Stud spacing not to exceed 24 in. OC.
 - C. **Gypsum Board*** – Gypsum board sheets to be installed to a min total thickness of 5/8 or 1-1/4 in. on each side of the wall for a 1 or 2 hr fire rated assemblies, respectively. Wall to be constructed as specified in the individual Wall and Partition Design in the UL Fire Resistance Directory, except that a nom 3/4 in. gap shall be maintained between the top of the gypsum board and the lower surface of the floor. The screws attaching the wallboard to studs at the top of the wall shall be located 1in. below the bottom of the U-shaped deflection channel (Item 3A).

The hourly fire rating of the joint system is dependent on the hourly fire rating of the wall.
3. **Joint System** – Max separation between bottom of floor and top of wall is 3/4 in. The joint system is designed to accommodate a max 33 percent compression or extension from its installed width. The joint system consists of a deflection channel and a fill material, as follows:
 - A. **Deflection Channel** – A nom 3-5/8 in. wide by min 2 in. deep min 24 gauge (or heavier) steel U-shaped channel. Deflection channel secured to floor assembly with steel fasteners, spaced max 24 in. OC. The ceiling runner (Item 2A) is installed within the deflection channel to maintain a 1 in. gap between the top of the ceiling runner and the top of the deflection channel. The ceiling runner is not fastened to the deflection channel.



- B. **Fill, Void or Cavity Material* – Sealant** – Min 5/8 in. thickness of fill material installed on each side of the wall between the top of the gypsum board and the bottom of floor, flush with each surface of wallboard.
John Wagner & Associates Inc. – GrabberGard EFC

CONFIGURATION B

2. **Wall Assembly** – The 1 or 2 hr fire rated gypsum wallboard/steel stud wall assembly shall be constructed of the materials and in the manner described in the individual U400 or V400 - Series Wall or Partition Design in the UL Fire Resistance Directory and shall include the following construction features:
- A. **Steel Floor and Ceiling Runners** – Floor and Ceiling runners of wall assembly shall consist of galv steel channels sized to accommodate steel studs (Item 2B). Ceiling runner is secured to floor with steel masonry anchors spaced a max of 24 in. OC.
 - A1. **Light Gauge Framing* – Slotted Ceiling Runner** – As an alternate to the ceiling runner in Item 2A, slotted ceiling runner to consist of galv steel channel with slotted flanges sized to accommodate steel studs (Item 2B). Slotted ceiling runner is secured to floor with steel masonry anchors spaced max 24 in. OC.
METAL-LITE – The System
SLIPTRACK SYSTEMS, INC – SLP-TRK
 - A2. **Light Gauge Framing* – Clipped Ceiling Runner** – As an alternate to the ceiling runner in Item 2A, 2A1, clipped runner to consist of galv steel channel with clips preformed in track flanges which positively engage the inside flange of the steel studs (Item 2B). Track sized to accommodate steel studs (Item 2B). Track flanges to be min 2-1/2 in. Clipped ceiling runner installed perpendicular to direction of fluted steel floor units and secured to valleys with steel fasteners spaced 24 in. OC.
TOTAL STEEL SOLUTIONS LLC – Snap Trak
 - A3. **Light Gauge Framing* – Vertical Deflection Ceiling Runner** – As an alternate to the ceiling runner in Item 2A, 2A1 or 2A2, vertical deflection ceiling runner to consist of galv steel channel with slotted vertical deflection clips mechanically fastened within runner. Slotted clips, provided with step bushings, for permanent fastening of steel studs. Vertical deflection ceiling runner installed perpendicular to direction of fluted steel floor or roof deck and secured to valleys with steel fasteners spaced max 24 in. OC.
THE STEEL NETWORK INC – VertiTrack VTD358, VTD400, VTD600 and VTD800
 - B. **Studs** – Steel studs to be min 3-5/8 in. wide. Studs cut 1/2 to 3/4 in. less in length than assembly height. Steel studs shall not be secured to ceiling runner when slotted ceiling runner (Item 2A1) is used, steel studs secured to slotted ceiling runner with No. 8 by 1/2 in. long wafer head steel screws at midheight of slot on each side of wall. When vertical deflection ceiling runner (Item 2A3) is used, steel studs secured to slotted vertical deflection clips, through bushings, with steel screws at mid-height of each slot Stud spacing not to exceed 24 in. OC.
 - C. **Gypsum Board*** – Gypsum board sheets to be installed to a min total thickness of 5/8 or 1-1/4 in. on each side of the wall for a 1 or 2 hr fire rated assemblies, respectively. Wall to be constructed as specified in the individual Wall and Partition Design in the UL Fire Resistance Directory, except that a nom 3/4 in. gap shall be maintained between the top of the gypsum board and the lower surface of the floor. The screws attaching the gypsum board to studs at the top of the wall shall be located 1in. below the bottom of the ceiling runner (Item 2A).
The hourly fire rating of the joint system is dependent on the hourly fire rating of the wall.
3. **Fill, Void or Cavity Material* – Sealant** – Max separation between bottom of floor and top of wall is 3/4 in. The joint system is designed to accommodate a max 33 percent compression or extension from its installed width. Min 5/8 in. thickness of fill material installed on each side of the wall between the top of the gypsum board and the bottom of floor, flush with each surface of wallboard.
John Wagner & Associates Inc. – GrabberGard EFC

*Bearing the UL Classification Marking



System No. HW-D-1050

Assembly Rating – 3 Hr

Joint Width – 4 in. Max

Class II Movement Capabilities – 12.5% Compression or Extension

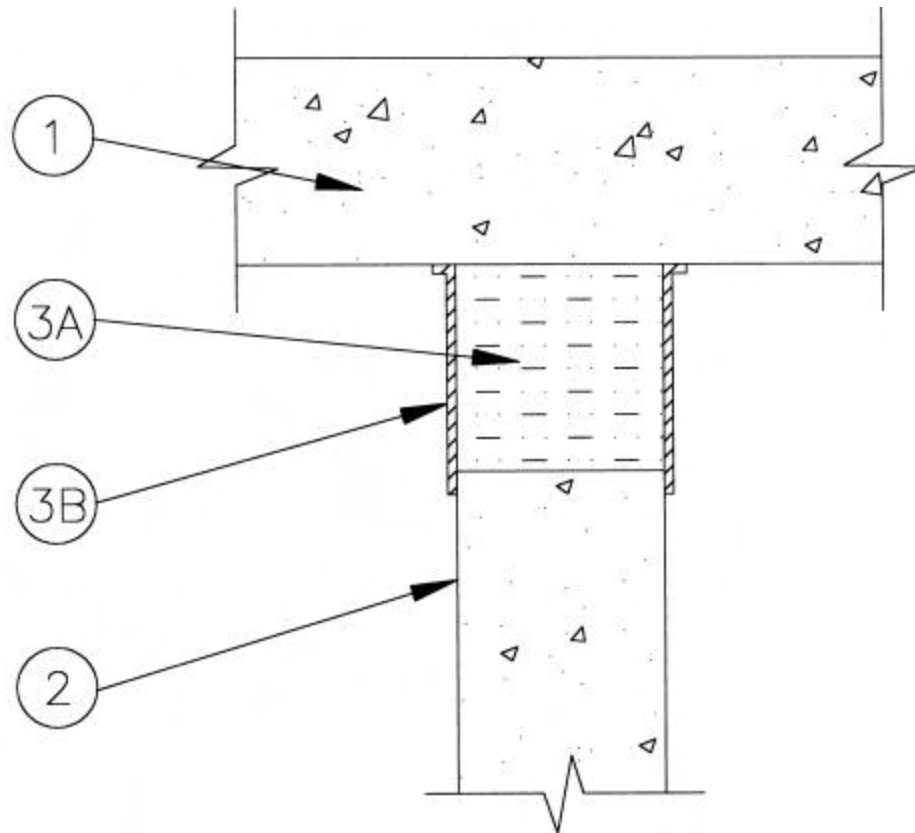

1. **Floor Assembly** – Min 4 1/2 in. thick steel-reinforced lightweight or normal weight (100-150 pcf) structural concrete.
2. **Wall Assembly** – Min 4 1/2 in. thick reinforced lightweight or normal weight (100-150 pcf) structural concrete. Wall may also be constructed of any UL Classified **Concrete Blocks***.
See **Concrete Blocks** (CAZT) category in the Fire Resistance Directory for names of manufacturers.
3. **Joint System** – Max width of joint (at time of installation of joint system) is 4 in. The joint system is designed to accommodate a max 12.5 percent compression or extension from its installed width. The joint system shall consist of the following:
 - A. **Forming Material*** – Min 4 pcf mineral wool batt insulation installed into joint opening as a permanent form. Batt cut to min width of 4 1/2 in. and installed edge-first into joint opening, parallel with joint direction, such that batt sections are compressed min 33 percent in thickness and such that the compressed batt sections are flush with the top surface of floor.
IIG Minwool LLC – Paroc Safing Insulation
Thermafiber LLC – Type SAF
Rock wool Manufacturing Company – Delta Safing Board
 - B. **Fill, Void or Cavity Material* – Sealant** – Min 1/16 in. dry thickness of fill material sprayed or brushed on joint completely covering mineral wool and overlapping a min of 1/2 in. onto concrete floor and wall assembly.

John Wagner & Associates Inc. – GrabberGard EFS

*Bearing the UL Classification Marking