

Firestop Products & Systems Submittal Documentation

Service Penetrations
 Construction Joints/Gaps

Project:

Contractor:

Installer:

Supplier:

Grabber Construction Products, Inc.
866-237-GRAB(4722)

Distributor:

Table of Contents

| | |
|--|------|
| | PAGE |
| Table of Contents | 2 |
| General Certificate of Conformance | 3 |
| LEEDS Information | |
| United States LEEDs | 4 |
| Product Data Sheets | |
| GrabberGard EFC. | 6 |

Joint Systems

Type of assembly joint system:

BW – Bottom of Wall

FF – Floor to Floor

FW – Floor to Wall

HW – Head of Wall

PJ – Perimeter Joint

WW – Wall to Wall

| Type of Assembly | System # | GrabberGard Product Used | System Details | |
|------------------|-----------|--------------------------|---|----|
| BW | BW-S-0010 | EFC | 1 & 2 hr - bottom of gyp wall to conc floor joint | 10 |
| FF | FF-D-0048 | EFC | 2 hr - floor to floor joint - 1 in. joint | 11 |
| FW | FW-D-0039 | EFC | 2 hr - floor to wall - 1 in. joint | 12 |
| WW | WW-D-0078 | EFC, IFC | 2 hr - concrete wall to concrete wall -3/4in. joint | 13 |
| WW | WW-S-0054 | EFC, IFC | 2 hr - concrete wall to gypsum wall -3/4 in. joint | 14 |

| | |
|---|----|
| Material Data Sheets | |
| GrabberGard EFC. | 15 |
| Equipment and Installation | |
| Spraying Instructions GrabberGard EFC | 18 |
| Locations | |
| Grabber Branch Locations | 25 |

GENERAL CERTIFICATE OF CONFORMANCE

Grabber Construction Products, Inc.
205 Mason Circle, Concord, CA 94520

GrabberGard EFC, IFC & EFS

THESE PRODUCTS ARE TESTED TO THE FOLLOWING TEST STANDARDS

In the USA:

ASTM E-814 Standard Test Method for Fire Tests of Through Penetrations Fire Stops

ASTM E-1399 Cyclic Movement and Measuring the Minimum and Maximum Joint Widths of Architectural Joint Systems

UL 1479 Fire Tests of Through-Penetration Firestops

UL 2079 Tests for Fire Resistance of Building Joint Systems

In Canada:

ULC S115-M95 Standard Method of Fire Tests of Firestop Systems

TESTED BY THIRD PARTY AGENCIES

Underwriters Laboratories, Inc. (UL)
Intertek Testing Services Inc. – Warnock Hersey (WHI)

No Asbestos or PCBs are used or contained in this product.

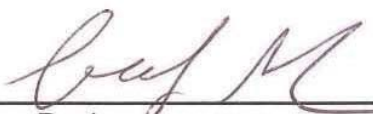

George Rouhana
Executive Director

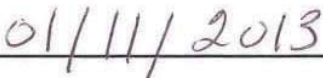

Date



LEED is a trademark of the US Green Building Council

To Whom It May Concern:

Re: LEED Information on Grabber Construction Products' GrabberGard Firestopping Products

This letter will detail the contribution of Grabber Construction Products' GrabberGard firestopping products to the LEED® (Leadership in Energy and Environmental Design) Green Building Rating System® in accordance with LEED-NC Version 2009 For New Construction & Major Renovations.

In reference to LEED® Material and Resource (MR) – Credit 2 – Construction Waste Management – the following Grabber' materials are recyclable where facilities exist:

| <u>Packaging</u> | <u>Recyclable Product</u> | <u>Weight Per Unit</u> |
|-------------------------------------|---------------------------|---|
| Carton | Cardboard | 56 g – EBI-60 70 g – Putty Stick 190 g – 10 oz plastic tube 350 g – 20 oz foil package 410 g – 10 L plastic jar 600 g – 29 oz plastic tube |
| 10.1 oz (300ml) plastic tube | HDPE | 49 g / Tube |
| 20 oz (600ml) foil pack | Aluminum | 5 g / Pack |
| 29 oz (850ml) tube | Fiberboard | 84 g / Tube |
| 35.2 oz (1L) EZ pour plastic bottle | HDPE | 50 g / Bottle |
| 2.5 gallon (9.5L) plastic pai | HDPE | 0.8 kg / Pail |
| 2.65 gallon (10 L) plastic jar | HDPE | 345 g / Jar |
| 5 gallon (18.9L) plastic pail | HDPE | 1.2 kg / Pail |
| Wooden pallet | Wood | 21 kg / Pallet |

In reference to LEED® Material and Resources – Credits 4.1 & 4.2 – Recycled Content, all GrabberGard firestopping products contain 5% post-consumer recycled content.

In reference to LEED® Material and Resources – Credit 5 - Regional Materials, Grabber can confirm that a minimum of 50% of the raw materials used in manufacturing the GrabberGard firestopping products are sourced and processed within a 500-miles radius of our manufacturing facility in Vancouver, BC.

If the project site is located within a 500-mile radius of our manufacturing site then this manufacturing site can contribute to earning Materials and Resource Credit 5.1 & 5.2.

The volatile organic content (VOC) of GrabberGard firestopping products are listed below and meets the minimum LEED® requirements for low-emitting materials. These materials can assist to earn Indoor Environmental Quality (IEQ) – Credit 4.1 – Low-Emitting Materials: Adhesives & Sealants (Architectural Sealants) & Credit 4.2 – Low-Emitting Materials: Paints & Coatings (Architectural Sealants).

| GrabberGard Firestopping Product | VOC content [g/L] |
|----------------------------------|-------------------|
| EFC | 32.5 |
| IFC | 37.1 |
| EFS | 81.3 |

If you have any additional questions, please feel free to contact us at (800) 237-4722.

PRODUCT DATA SHEET GRABBERGARD EFC

1 of 4

Description

GRABBERGARD EFC is a superior performance latexbased endothermic firestop caulk. It has excellent adhesion and bonding characteristics and will not slump or sag out after it has been properly installed. GRABBERGARD EFC elastomeric caulk has been designed to stop the passage of fires, smoke and fumes through fire-rated assemblies after it has been fully cured. GRABBERGARD EFC is chemically compatible with plastic pipes and cable jackets and is water resistant after fully cured. Once cured Grabbergard EFC provides a durable and flexible firestop and can be repaired if damaged or cut.

Applications

GRABBERGARD EFC firestop caulk provides an effective firestop seal when used as a single or multiple component system for through-penetrations, construction joints and voids. To make certain installation is correct, consult manufacturer's current listings, as well as, Third Party published Fire Resistance Directories and/or their websites. GRABBERGARD EFC common uses and features are listed below:

Used on: Single and multiple penetrations

Metallic pipes

- Copper, steel, cast iron
- Conduits

Non-metallic pipes

- ABS, CPVC, FRPP, PE, PEX, PVC
- Rigid and ENT conduit

Insulated pipes

- Fiberglass
- AB/PVC

Electrical cables and wires

- Jacket & non-jacketed

Cable trays

Mechanical ducts

Construction joints/gaps

- Top-of-Wall
- Horizontal and vertical joints
- Perimeter floor joints

Voids

Common construction substrate materials:

- Concrete
- Concrete block
- Steel deck
- Wood
- Gypsum wallboard

Features: Red Color
Non-toxic
Safe and easy to use
Easy clean up (Water Only)
Low volatile organic content (VOC)
No asbestos or PCB
Water resistance (when fully cured)
Mildew resistant (when fully cured)
Paintable (with latex based paints)
Excellent application characteristics

- Flows easily
- No slump
- Superior bond and adhesion

Excellent acoustic properties
Seals smoke and gases
One-component systems

Advantages

Endothermic — When GRABBERGARD EFC is exposed to high temperatures or direct fire, it releases water vapor, forms a solid char and retards the spread of fire.

Single Component

GRABBERGARD EFC Caulk can be used as a single component firestop in many applications. Just install the caulk directly into the opening without using fibrous insulation materials. In many situations GRABBERGARD EFC will replace the more conventional intumescent firestop devices such as pipe collars and wrap strips. This will reduce both the cost and installation time.

Versatility

GRABBERGARD EFC adheres to dry and damp concrete, wood, metals and other common construction material surfaces to form an air and watertight bond. GRABBERGARD EFC can be painted over using a latexbased paint after fully cured.

Flexibility

When installed GRABBERGARD EFC is properly installed in construction joints it will allow up to 33 per cent extension and compression movement of the intersecting assemblies. It will also accommodate longitudinal and lateral movement of through and partial service penetrating items installed in the assembly. GRABBERGARD EFC will remain flexible after it has fully cured.

Disclaimer: All technical advice, recommendations and services rendered by the seller gratis. They are based on technical data, which the seller believes to be reliable, and are intended for use by persons having the skills and know how, at their own discretion and risk. In no event will the seller be liable for any consequential damages arising out of the use of this product.



PRODUCT DATA SHEET GRABBERGARD EFC

2 of 4

Limitations

Consult the Installation Instructions, Storage and Handling and Transportation Sections. Exposure to rain, running or standing water; before, the sealant is cured may cause the installed material(s) to wash out. The curing process occurs naturally through the evaporation of its water content into the atmosphere. Slower cure times may be experienced if the sealant is installed at low temperatures, damp and/or in high humidity environments. Any materials used in the firestop system for damming, insulation or support that may not allow for the free passage of air could result in longer curing times. The environment in which the compound is being used should be considered when estimating cure times.

Compliance/Approvals

GRABBERGARD EFC has been Third Party tested for many firestop applications. They meet or exceed the requirements of ASTM E 814; ASTM E 119; UL 1479; UL 2079; ULC S 115- M95; ULC S 101; ASTM E 84. Underwriters Laboratories (UL) and Intertek Warnock Hersey are Third Party fire endurance testing agencies accredited by ICBO, BOCA, and SBCCI (National Evaluation Services) in the United States.

Additional Testing

GRABBERGARD EFC caulk becomes an integral component in a complete building system of walls, floor/ ceiling assemblies, service penetration, joints and the like. For this reason, its physical compatibility to other materials used in these complex configurations requires more than the routine firestopping product testing. The results of these additional tests are listed in Table 1, Physical and Chemical Properties.

GRABBERGARD EFC caulk has proven that it has all the physical and chemical characteristics desired in a firestopping product. After it has been installed and fully cured, it has excellent stability and flexibility, even after four weeks at freezing temperatures of -15°F (-26°C) and exposure to extreme temperatures of 300 F(149°C) for 24 hours. Dimensional changes were well within the accepted standards (<2% per ASTM C 356). Dynamic testing has demonstrated the high elasticity properties of GRABBERGARD EFC.

Installation Instructions

GRABBERGARD EFC must be installed in compliance with the listed system designs published by Third Party testing laboratories (UL, ITS Warnock Hersey). Refer to their respective published Fire Resistance Directories and/ or their Websites. GRABBERGARD EFC does not require mineral wool insulation in many applications.

Prep-work

To install properly, remove excessive dust, dirt, debris, grease, oil and standing water.

Application

Apply caulking material with standard cartridge or bulkloading application guns or trowel in place with standard troweling tools. Install the required amount of caulking material into the opening using sufficient pressure to ensure it is in contact with all surfaces, substrates and/ or penetrating items. The manufacturer recommends tooling the surface with a moist putty knife or similar tooling utensil. Tooling the caulking material will create a stronger bond and a smooth finish especially on irregular or porous surfaces. Do not apply GRABBERGARD EFC to mineral wool that is or was wet from exposure to water, standing water, rain or snow.

Caution: Mineral wool may cause eye, skin or respiratory tract irritation. Avoid contact with eyes, skin of clothing. Recommend using gloves and goggles. Refer to mineral wool manufacturer's Material Safety Data Sheets.

Installation Temperature

For best results, installation temperatures should be between 45°-90°F(7°-32°C).

Maintenance

No special maintenance is required after the GRABBERGARD EFC sealant is installed and fully cured. If, after installation, the GRABBERGARD EFC sealant is damaged or cut, repairs should be made with the same sealant.

Disclaimer: All technical advice, recommendations and services rendered by the seller gratis. They are based on technical data, which the seller believes to be reliable, and are intended for use by persons having the skills and know how, at their own discretion and risk. In no event will the seller be liable for any consequential damages arising out of the use of this product.



PRODUCT DATA SHEET GRABBERGARD EFC

3 of 4

Manufacturer's Recommendations

The manufacturer recommends this product be installed by those trained in proper installation procedures (Approved Installer Card) and be able to read and understand a firestop system design listing (i.e. UL or WHI Listed System Design).

Storage and Handling

Keep product stored in a protected covered area in its original unopened containers. Manufacturer recommends storage temperatures to between 40°-90°F(4°-32°C).

DO NOT ALLOW TO FREEZE

Product has a shelf life of one(1) year. Stock rotation program is recommended.

Transportation

Recommended transportation temperatures should be between 40°-90°F (4°-32°C).

DO NOT ALLOW TO FREEZE**First Aid**

In case of contact with eyes, flush with water and consult a physician. Skin contact, clean up thoroughly with water or soapy water. Consult a physician if eye or skin irritation develops or is persistent. **SEE MSDS FOR ADDITIONAL INFORMATION.**

Availability

GRABBERGARD IFC caulk is supplied in:

- 10 fl . oz. (300ml) plastic cartridges
- 29 fl . oz. (850ml) cartridges
- 20 fl . oz. (590ml) sausages
- 5 gal. (18.9L) tapered plastic pails

Coverage

Estimated product usage will vary depending on opening size and configuration. Check GRABBERGARD'S estimating charts for coverage.

Warranty

Grabber Construction Products will not accept liability for more than product refund. Any claim regarding product defect must be received in writing within 1 year from date of shipment. Grabber makes no other Warranty or Guarantee express or implied, including warranties of fitness for a particular purpose or merchantability. The seller shall assume no other liability for incidental or consequential damages arising out of the sale or use of this product.

Technical Services

For technical information and assistance regarding application information, code requirements and performance specifications:

Toll Free 1-866-237-GRAB(4722)

Web Site www.grabberman.com

Disclaimer: All technical advice, recommendations and services rendered by the seller gratis. They are based on technical data, which the seller believes to be reliable, and are intended for use by persons having the skills and know how, at their own discretion and risk. In no event will the seller be liable for any consequential damages arising out of the use of this product.



PRODUCT DATA SHEET GRABBERGARD EFC

Table 1 – Physical and Chemical Properties

As Supplied

| | |
|--------------------------------------|-------------------|
| Type of Polymer | Waterborne Resin |
| Odor | Mild Latex |
| Solids Content (Wt%) | 77 ± 2% |
| Application Temperatures | 45°-90°F(7°-32°C) |
| Viscosity (ASTM D-2196) | 560000-744000cps |
| Extrudability | Passed |
| Color - (ASTM C-834) | Rust Red |
| Specific Gravity - (ASTM D-1475) | 1.40-1.50 |
| Dry Time - (ASTM D-1640) | |
| Dry to touch @ 6mils | 20-30 mins |
| Full Cure Time | 7-21 days |
| (depends on thickness & environment) | |
| pH - (ASTM E-70) | 8-9 |

As Cured

| | |
|--|-------------------|
| In Service Temperature | up to 120°F(49°C) |
| Moisture Absorption | < 4% |
| Stability | Passed |
| [Dimensional, Cracking, Blisters, Flexibility] | |
| Corrosion - (ASTM C-655) | Passed |
| [for Aluminum, Copper, Steel, Galvanized Steel, Stainless Steel] | |
| Volume Shrinkage - (ASTM C-1241) | Passed |
| Chemical Compatibility - (ASTM D-543) | Passed |
| Slump Test - (ASTM D-2202 - Modified) | Passed |
| Hardness - (ASTM D-2240, Shore A) | 22 |
| Freeze/Thaw - (ASTM D-2243) | Excellent |
| Tensile Properties - (ASTM D-2370) | |
| Tensile Strength | 26 psi |
| Maximum Elongation | 1400% |
| Corrosion - (ASTM D-5894) | Passed |
| Surface Burning Characteristics - (ASTM E-84) | |
| Flame Spread Index | < 25 |
| Smoke Developed Index | < 50 |
| STC Sound Transmission Loss - (ASTM 90-99) | Full Recovery |

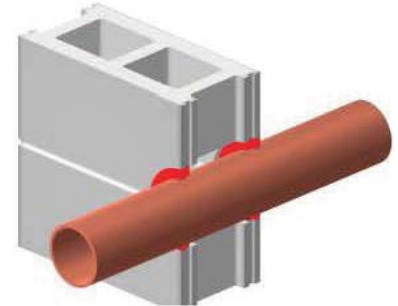

Typical Pipe Penetration

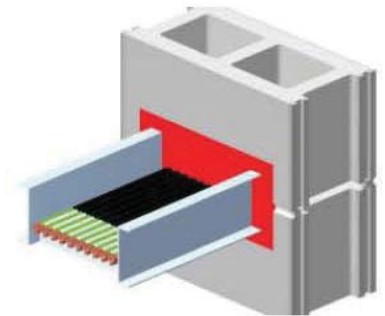

Disclaimer: All technical advice, recommendations and services rendered by the seller gratis. They are based on technical data, which the seller believes to be reliable, and are intended for use by persons having the skills and know how, at their own discretion and risk. In no event will the seller be liable for any consequential damages arising out of the use of this product.



System No. BW-S-0010

Assembly Ratings 1 & 2 Hr (See Item 2)

Nominal Joint Width – 3/4 in.

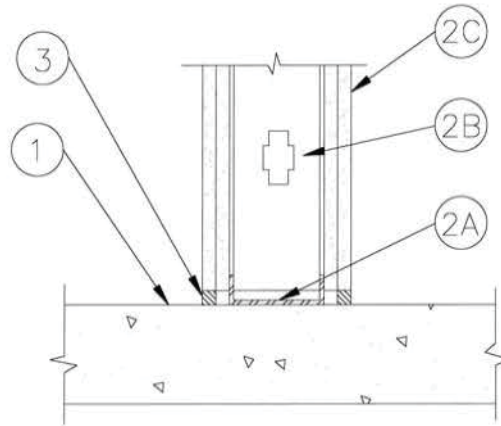

1. **Floor Assembly** – Min 4-1/2 in. thick reinforced lightweight or normal weight (100-150 pcf) structural concrete. Floor may also be constructed of any 6 in. thick UL Classified hollow-core **Precast Concrete Units***.

See **Precast Concrete Units** category in the Fire Resistance Directory for names of manufactures.

2. **Wall Assembly** – The 1 or 2 hr fire-rated gypsum board/steel stud wall assembly shall be constructed of the materials and in the manner specified in the individual U400 or V400 Series Wall or Partition Design in the UL Fire Resistance Directory. In addition, the wall may incorporate a head-of-wall joint system constructed as specified in the HW Series Joint Systems in the UL Fire Resistance Directory. The wall shall include the following construction features:

- A. **Steel Floor Runner** – Floor runners of wall assembly shall consist of min No. 25 gauge galv steel channels sized to accommodate steel studs (Item 2B). Floor runners to be provided with min 1-1/4 in. flanges. Runners secured with steel fasteners spaced 12 in. OC.
- B. **Studs** – Steel studs to be min 2-1/2 in. wide. Studs cut 1/2 to 3/4 in. less in length than assembly height with bottom nesting in, resting on and fastened to floor runner with sheet metal screws. Stud spacing not to exceed 24 in. OC.
- C. **Gypsum Board*** – Gypsum board installed to a min total thickness of 5/8 or 1-1/4 in. on each side of wall for a 1 or 2 hr rated wall, respectively. Wall to be constructed as specified in the individual U400 or V400 Series Design in the UL Fire Resistance Directory, except that a max 3/4 in. gap shall be maintained between the bottom of gypsum board and top of concrete floor.

The hourly fire rating of the joint system is equal to the hourly fire rating of the wall.

3. **Fill, Void or Cavity Material* – Sealant** – Max separation between top of floor and bottom of gypsum board is 3/4 in. Min 5/8 in. thickness of fill material installed on each side of the wall between the bottom of the gypsum board and the top of the concrete floor, flush with each surface of the wall.

GRABBER CONSTRUCTION PRODUCTS INC – GrabberGard EFC

*Bearing the UL Classification Mark



System No. FF-D-0048

Assembly Ratings 1 & 2 Hr (See Item 2)

Nominal Joint Width – 1 in.

Class II Movement Capabilities – 25% Compression or Extension

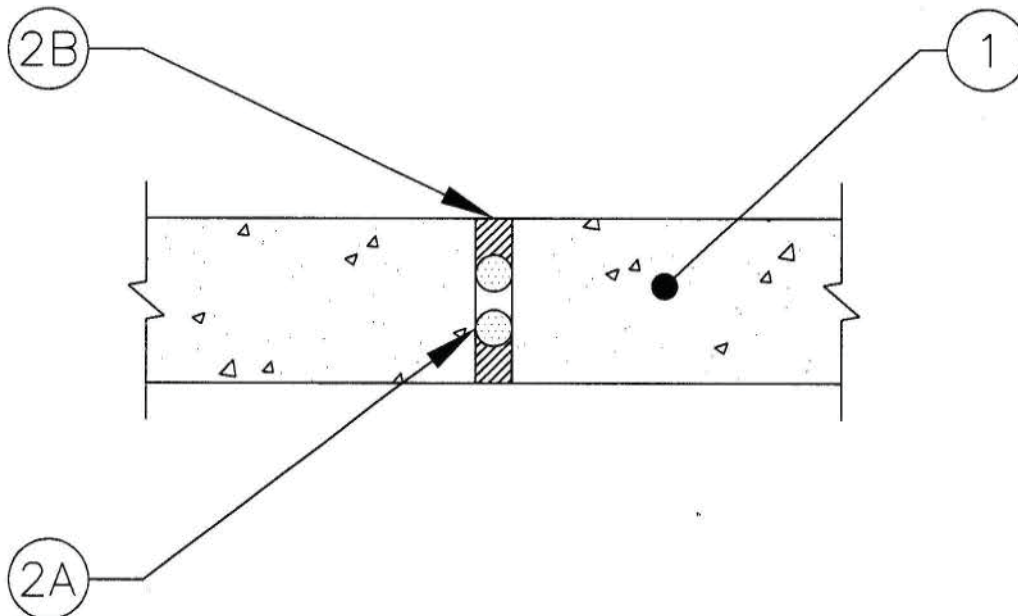

1. Floor Assembly – Min 4-1/2 in. thick steel-reinforced lightweight or normal weight (100-150 pcf) structural concrete.
2. Joint Systems – Max width of joint (at time of installation of joint system) is 1 in. The joint system is designed to accommodate a max 25 percent compression or extension from its installed width. The joint system shall consist of the following:
 - A. Packing Material – Backer Rod – Nom 1-1/4 in. diam polyethylene backer rod compressed and firmly packed into joint opening and recessed from both sides of floor to accommodate required thickness of fill material.
 - B. Fill, Void or Cavity Material* – Sealant – Min 1 in. thickness of fill material applied within the joint, flush with both surfaces of floor.

GRABBER CONSTRUCTION PRODUCTS INC – GrabberGard EFC

*Bearing the UL Classification Marking





System No. FW-D-0039

Assembly Ratings 2 Hr

Nominal Joint Width – 1 in.

Class II Movement Capabilities – 25% Compression or Extension

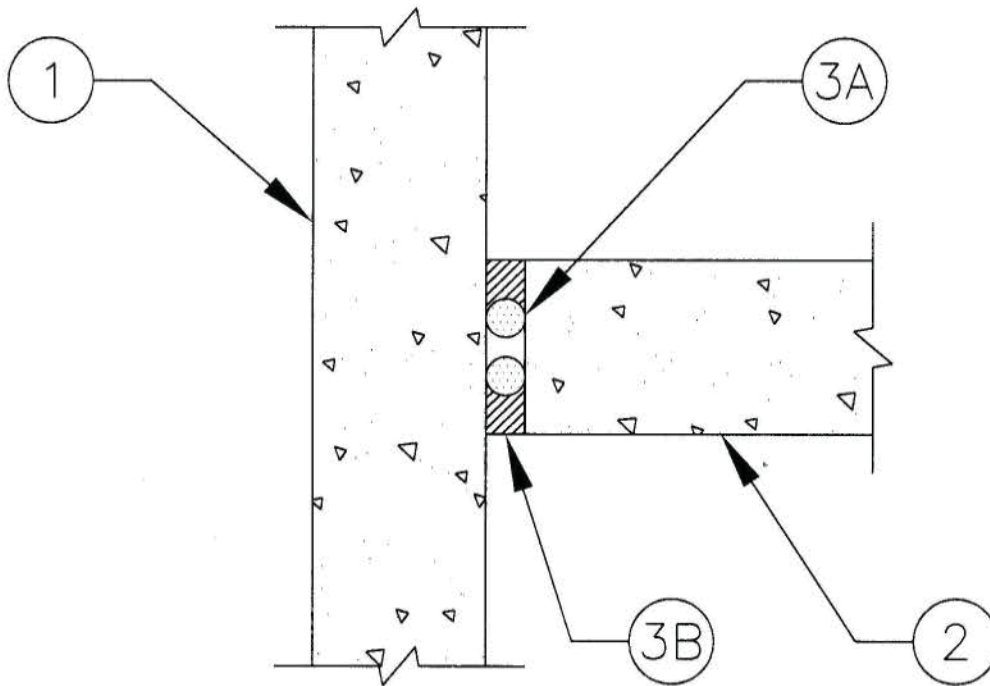

1. **Wall Assembly** – Min 4-1/2 in. thick reinforced lightweight or normal weight (100-150 pcf) structural concrete. Wall may also be constructed of any UL Classified **Concrete Blocks***.
See Classified **Concrete Blocks** (CATZ) category in the Fire resistance Directory for names of manufactures.
2. **Floor Assembly** – Min 4-1/2 in. thick steel-reinforced lightweight or normal weight (100-150 pcf) structural concrete.
3. **Joint Systems** – Max width of joint (at time of installation of joint system) is 1 in. The joint system is designed to accommodate a max 25 percent compression or extension from its installed width. The joint system shall consist of the following:
 - A. **Packing Material – Backer Rod** – Nom 1-1/4 in. diam polyethylene backer rod compressed and firmly packed into joint opening and recessed from both sides of wall to accommodate required thickness of fill material.
 - B. **Fill, Void or Cavity Material* – Sealant** – Min 1 in. thickness of fill material applied within the joint, flush with both surfaces of wall.

GRABBER CONSTRUCTION PRODUCTS INC – GrabberGard EFC

*Bearing the UL Classification Marking





System No. WW-D-0078

Assembly Rating – 2 Hr

Nominal Joint Width – 3/4 in. (19 mm)

Class II Movement Capabilities – 33% Compression and Extension

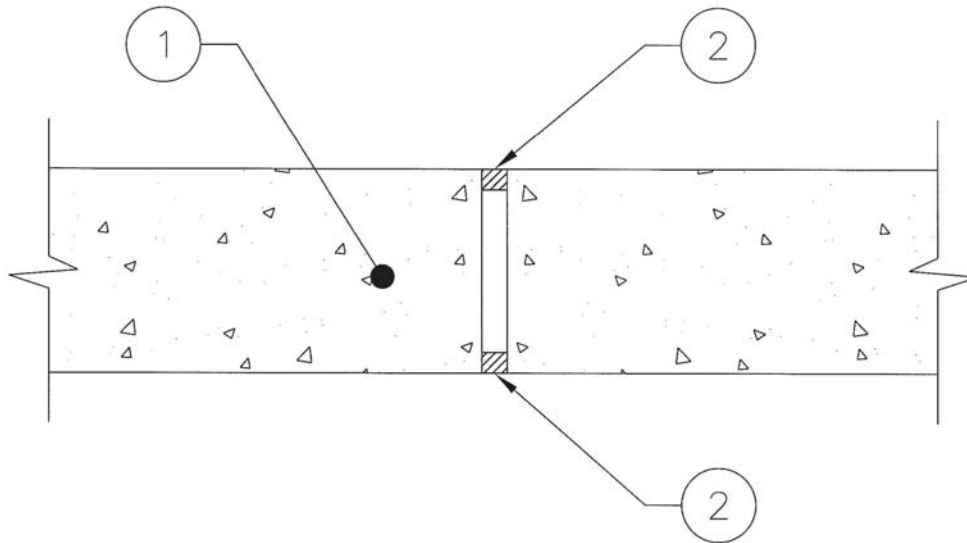

1. **Wall Assembly** – Min 4-1/2 in. (114 mm) thick steel-reinforced lightweight or normal weight (100-150 pcf or 1600- 2400 kg/m³) structural concrete. Wall may also be constructed of any UL Classified **Concrete Blocks**.*
See **Concrete Blocks** (CATZ) category in the Fire Resistance Directory for names of manufacturers.
2. **Joint System – Fill, Void or Cavity Materials*** – Max width of joint (at time of installation) is 3/4 in. (19 mm). The joint system is designed to accommodate a max 33 percent compression or extension from its installed width. The joint system shall consist of a min 5/8 in. (16 mm) thickness of fill material applied within the joint, flush with each surface of wall.

GRABBER CONSTRUCTION PRODUCTS INC – GrabberGard IFC or GrabberGard EFC

*Bearing the UL Classification Marking





System No. WW-S-0054

Assembly Rating – 1 and 2 Hr (See Item 1)

Nominal Joint Width – 3/4 in. (19 mm)

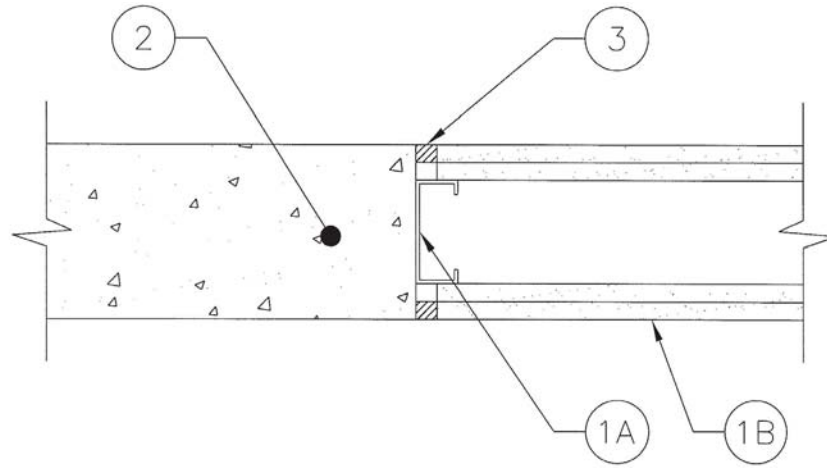

1. **Wall Assembly** – The 1 or 2 hr fire-rated gypsum board/steel stud wall assembly shall be constructed of the materials and in the manner specified in the individual U400 or V400 Series Wall or Partition Design in the UL Fire Resistance Directory and shall include the following construction features:

- A. **Studs** – Steel studs to be min 3-1/2 in. (89 mm) wide by 1-1/4 in. (32 mm) deep corrosion protected min 25 MSG steel channels. Studs not to exceed 24 in. (610 mm) OC. Stud installed nominally centered at joint location.
- B. **Gypsum Board*** – Gypsum board sheets installed to a min total thickness of 5/8 in. (16 mm) or 1-1/4 in. (32 mm) on each side of wall for 1 and 2 hr fire rated assemblies, respectively.

The hourly rating of the joint system is dependent on the hourly rating of the wall assembly in which it is installed.

2. **Wall Assembly** – Min 4-1/2 in. (114 mm) thick steel-reinforced lightweight or normal weight (100-150 pcf or 1600- 2400 kg/m³) structural concrete. Wall may also be constructed of any UL Classified **Concrete Blocks**.*

See **Concrete Blocks** (CATZ) category in the Fire Resistance Directory for names of manufacturers.

3. **Joint System – Fill, Void or Cavity Materials*** – Max width of joint (at time of installation) is 3/4 in. (19 mm). The joint system shall consist of a min 5/8 in. (16 mm) thickness of fill material applied within the joint, flush with each surface of wall.

GRABBER CONSTRUCTION PRODUCTS INC – GrabberGard IFC or GrabberGard EFC

*Bearing the UL Classification Marking



MATERIAL SAFETY DATA SHEET

MSDS Name: GrabberGard EFC

Revision Date: August 30, 2012

1. Product and Company Identification

Product Name: GrabberGard EFC
 Product Code: GGEFC10, GGEFC 20, GGEFC29, GGEFC5
 Supplier: Grabber Construction Products
 205 Mason Circle
 Concord, CA 94520
 Medical Emergency: Passive Fire Protection Partners, 1412 Derwent Way, Delta, BC V3M 6H9, (800) 810-1788
 Product Information: 800-877-TURN (Concord, California) 8:00 a.m. - 4:00 p.m. PST

2. Composition/Information on Ingredients

| Ingredient | CAS Number | % (wt.) | LC50 (rat) | LD50 (rat) | TLV | STEL |
|------------------------|---------------|---------|------------|--------------|--------|------|
| Calcium Carbonate | 1317-65-3 | < 50 | N/A | N/A | N/A | N/E |
| Vinyl Acetate Polymers | Not disclosed | < 40 | N/A | N/A | N/A | N/A |
| Water | 7732-18-5 | < 25 | N/A | N/A | N/E | N/E |
| Auxiliary Chemicals | N/A | < 5 | N/A | 20 - 34 g/Kg | 50 ppm | N/A |
| Color Pigment | 1309-37-1 | < 0.5 | N/A | N/A | N/A | N/A |

3. Physical Properties

| | | | |
|--------------------------------|-------------------------|--------------------------|-------------|
| Appearance / Physical State | Red, viscous compound | Specific Gravity (@25°C) | 1.40 – 1.50 |
| Odour | Mild odour | Evaporation Rate | < 1 |
| Odour Threshold | Slightly aromatic odour | Boiling Point (°C) | > 100 |
| Vapour Pressure (mm Hg) | 18.51880 | Freezing Point (°C) | 0 |
| Vapour Density (Air = 1) | of Water vapor | pH | 8.0 – 9.0 |
| Coefficient of H2O/Oil Distrib | Not determined | VOC contents (g/L) | 32.5 |

4. Fire and Explosion Data

| | |
|----------------------------------|---|
| Flammability | No |
| Means of Extinction | Normal fire fighting procedures should be followed to avoid inhalation of smokes and gases. |
| Special Fire-fighting Procedures | Firefighters should wear the usual protective gear use self-contained breathing apparatus. |
| Auto-ignition Temperature (°C) | N/A |
| Flash Point (°C) / Method | N/A |
| Upper Flammable Limit (% Volume) | N/A |
| Lower Flammable Limit (% Volume) | N/A |
| Sensitivity to Mechanical Impact | No |
| Sensitivity to Static Discharge | No |
| Hazardous Combustion Products | Carbon Monoxide, Carbon Dioxide, aliphatic hydrocarbons and hydrocarbon oxidation products |

5. Reactivity Data

| | |
|----------------------------------|---|
| Stability | Stable at normal condition |
| Condition of Reactivity | Contact with incompatible substances |
| Incompatible Materials | Reacts with mineral acids and alkalis |
| Hazardous Decomposition Products | Dried films forced to burn will produce: Carbon Monoxide, Carbon Dioxide, and hydrocarbon oxidation products. |

MATERIAL SAFETY DATA SHEET

MSDS Name: GrabberGard EFC

Revision Date: August 30, 2012

| 6. Toxicological Properties | |
|--|---|
| Routes of Exposure | <input checked="" type="checkbox"/> Skin contact <input checked="" type="checkbox"/> Skin absorption <input checked="" type="checkbox"/> Eye contact <input checked="" type="checkbox"/> Inhalation <input checked="" type="checkbox"/> Ingestion |
| Effects of Acute Exposure to Product | Skin and eye irritation may occur after contact with the product. |
| Effects of Chronic Exposure to Product | None known |
| Exposure Limits | None known |
| Irritancy of Product | Slight on skin and eyes |
| Sensitization of Product | None known |
| Carcinogenicity | None known |
| Teratogenicity | None known |
| Reproductive Toxicity | None known |

| 7. First Aid Measures | |
|-----------------------|--|
| Eye Contact | Flush with large quantities of water gently for 15 minutes and get medical attention. |
| Skin Contact | Wash with soap and water. |
| Inhalation | Remove affected person away from source of exposure to fresh air and get medical attention IMMEDIATELY |
| Ingestion | Get medical attention IMMEDIATELY. |

| 8. Preventive Measures | |
|-------------------------------|--|
| Engineering Controls | Standard industrial ventilation is recommended. |
| Personal Protective Equipment | Chemical safety glasses and gloves were required during normal use and handling. |
| Eye Protection (Specify) | Face shield or chemical goggles were recommended. |
| Skin Protection (Specify) | Chemical resistant nitrile, neoprene or rubber gloves were recommended if contact to the product directly. |
| Respiratory (Specify) | Respiratory protection is not normally required. Use NIOSH/MSHA approved respirator if condition warrant. |
| Other | |

| 9. Precautions for Safe Handling and Use | |
|--|---|
| Handling Procedure and Equipment | N/A |
| Storage Requirement | Material should be kept in a closed container and stored between 4 – 32°C (40 – 90°F) |
| Spill, Leak or Releases | Wear protective equipment during cleanup. |
| Waste Disposal | Care should be taken to ensure that the material or it's containers and disposed of in an approved facility, state, provincial and local regulations. |
| Special Shipping Instructions | DO NOT FREEZE |

| 10. Regulation Information | |
|----------------------------|--|
| WHMIS | Not controlled |
| HMIS | Health 1, Flammability 0, Reactivity 0 |
| TDG Regulation | Not classified as a hazardous material. |
| TSCA | All ingredients of this product are on the inventory list. |
| DSL | All ingredients of this product are on the list. |

MATERIAL SAFETY DATA SHEET

MSDS Name: GrabberGard EFC

Revision Date: August 30, 2012

| 11. Preparation Information | |
|---|---|
| Prepared by: | Chemical Laboratory, Passive Fire Protection Partners |
| Preparation Date: | 11 March 2003 |
| Telephone: | (604) 515-1788 |
| Reason for Revision: | New formulation, rev 001, March 22, 2002 New format of MSDS, rev 002, September 16, 2004 Ingredient information updating, rev 003, November 10, 2006 MSDS reviewing, rev 004, December 30, 2008 Formulation updating, rev 005, August 24, 2009 Spelling mistake on Section of Precaution for Safe Handling and Use, rev 006, March 1, 2010 Formulation updating, rev007, January 3, 2011 Review, rev008, August 30, 2012 |
| Revision Date: | August 30, 2012 |
| Abbreviations Used: | % (wt.) = Weight Percentage ACGIH = American Conference of Governmental Industrial Hygienists CAS Number = Chemical Abstracts Series Number DSL = Domestic Substance List in Canada H = Hours HMIS = Hazardous Material Identification System IARC = International Agency for Research on Cancer LC50 = Lethal Concentration, 50% LD50 = Lethal Dose, 50% MSHA = Mine Safety and Health Administration N/A = Not Applicable or Not Available N/E = None Established NIOSH = The National Institute for Occupational Safety and Health NTP = National Toxicology Program OSHA = The Occupational Safety and Administration STEL = Short Term Exposure Limit TDG = Transportation of Dangerous Goods TLV = Threshold Limit Value TSCA = Toxic Substance Control Act in US VOC = Volatile Organic Compounds WHMIS = Workplace Hazardous Material Identification System |
| <p>This information is provided in good faith and is correct to the best of Grabber Construction Products' knowledge as of the date hereof; however, Grabber makes no representation as to its completeness or accuracy. Customers are encouraged to make their own determination as to the suitability of this product for their purpose prior to use. Grabber disclaims responsibility to damages of any kind resulting from the use of this information. THERE ARE NO WARRANTIES OR REPRESENTATIONS, EXPRESS OR IMPLIED, INCLUDING THOSE OF MERCHANTABILITY OR FITNESS FOR A PARTICULAR PURPOSE WITH RESPECT TO THIS INFORMATION OR TO THE PRODUCT IT DESCRIBES.</p> | |

CAULKING INSTRUCTIONS - GRABBERGARD EFC

Equipment and Caulking Installations Instructions Using Caulking Applicator Guns



There are different types of caulking applicator guns available. The recommended procedure when using the different styles will be described in Sections A and B. Section C will then describe the recommended procedures to follow to install the caulk and finish the job.

Section A – Applying Caulk in Plastic and Cardboard Fiber Foil Wrapped Cartridges

There are variety of applicator caulking guns available to do firestopping. We recommend using a smooth rod style rather than the less expensive ratchet rod type. When dispensing caulk from a 29 ounce-size cartridge, we recommend a rod type gun with at least a 12:1 thrust ratio. The higher thrust ratio means less hand fatigue since firestopping caulks are usually high viscous caulking. The higher thrust ratio will also help when the product becomes stiffer in the colder temperatures. (12:1 ration generates approximately 300 pound thrust)

For manual single component cartridge applicator guns.



Select the correct size manual drive frame-style cartridge gun for either the 10-ounce (300ml) or the larger 29-ounce (850ml) plastic or cardboard fiber foil wrapped tube type



Using a utility knife cut off the end of the plastic tip/nozzle to the desired opening size. The cut can be either straight across (90°) or angled (45°). Cutting too small of an opening will restrict the flow of material and a smaller bead size will result. The smaller the opening the higher the trigger action (pressure) required to move the material out of the tube.

On the 29 fl. oz. tubes, insert either a screwdriver or other pointed utensil into the plastic nozzle to puncture the membrane; which will allow the caulk material to flow.

CAULKING INSTRUCTIONS - GRABBERGARD EFC



Pull back the push rod of the frame-style caulking gun to its full extension.



Drop the cartridge into the frame insuring that the plastic nozzle of the cartridge is place through the opening in the end plate.



Repeatedly pull the trigger of the applicator guns until the push rod is advanced to the end of the cartridge. The caulk will begin to flow when some resistance is felt.



When the desired amount of material has been advanced, stop triggering; release the pressure by pressing the lever (tab) located at the back of the handle with your thumb. This causes the push rod to slip back stopping the flow of material.

REFER TO SECTION C TO COMPLETE THE INSTALLATION PROCEDURE.

CAULKING INSTRUCTIONS - GRABBERGARD EFC

Section B- Applying Caulk with Refillable Bulk Loading Applicator Gun



The caulking to be used is shipped in 5-gallon (18.9 liter) plastic tapered pails.



Advance the plunger and push the rod down to the end of the barrel. To begin the loading process, remove the front cap containing the nozzle.



With a utility knife, cut an opening in the plastic nozzle (cut can be straight across (90°) or angled (45°)).



Coat the threads at the end of the barrel with a solvent (oil) or water to prevent the accumulation of material.



Immerse the open end of the barrel into the material to a depth of approximately 1-inch. Move the immersed gun slightly around so the material will adhere and form an air seal.

CAULKING INSTRUCTIONS - GRABBERGARD EFC



Hold the barrel steady, grip the T-pull and slowly pull the push rod back drawing the material into the barrel. Pulling the rod back too quickly may result in air pockets and an incomplete fill.

Remove the gun from the pail of material and scrape off the excess amount that has accumulated on the barrel.

Replace the front cap and nozzle.

To stop the flow of product, stop triggering and depress the pressure and release tab on the handle.

Now you are ready to install the material into the openings and joints.



REFER TO SECTION C TO COMPLETE THE INSTALLATION PROCEDURE.

Section C – Installing Firestop Caulk

General Information

All firestopping installations must be performed in compliance with a tested and listed firestop system design. The testing laboratories like Underwriters Laboratories (UL) or Intertek (Warnock Hersey) publish these listings.

For the appropriate listing, consult the manufacturer's literature or the testing laboratories Fire Protection Directories and/ or their web sites.

The manufacturer recommends an individual who has been properly trained in the correct procedures should perform all firestop installations. The individual must be able to read and understand a tested firestop listing design.

The applicator should have the following materials and equipment to correctly and safely install firestop caulking.

- Safety Glasses
- Gloves
- Utility (box) knife
- Stainless Steel Spatula
- Cleaning rags
- Plastic spray water bottle (quart/liter) with finger pump trigger/nozzle

Areas to be firestopped should be clean, free from: water, excessive dirt, dust, debris and grease. For the best results, the ideal atmospheric temperatures and environment would be:

- Dry, 60°-75°F (15°C -24°C) & R.H. 50 %.

CAULKING INSTRUCTIONS - GRABBERGARD EFC

When the damming or fire insulation material is required, the following information should be considered before commencing.

- Backer rod used as a damming or support material should be installed into the opening in a thickness and compressed sufficiently as to not dislodge and fall out under normal building movement. Wrap the backer rod completely around the penetration(s) and recess it to accommodate the required amount of firestop caulk.
- Mineral wool when required, as an insulation material, it should be installed into the opening compressed to a thickness as to not dislodge nor fall out under normal building movement. The mineral wool, usually 4 pcf, should be installed to the compression required by the firestop listing. The orientation of the mineral wool is also very important and maybe the difference of the system being in compliance or not. For construction joints or through penetration in floor (horizontal) rated assemblies, the mineral wool or similar fibrous material should be installed with the lamination in a vertical orientation assemblies. The opposite is the rule of joints and through penetrations in wall (vertical) assemblies. Here the laminations should be placed in a horizontal orientation. Installing the mineral wool in these different lamination directions allows the material to be compressed to the density required for the fire rating and building movement.
- Do not install mineral wool that is or has become wet i.e. exposure to water, rain, or snow.

Water base caulks adhere to some construction materials better than others. Applying a light mist of water to these surfaces can in some instances, help the bonding process. Mineral wool, is one of these materials, especially when it is in a vertical orientation.

Tooling the installed material can be done in several ways:

- Dry tooling: After the material is put in place, using a spatula or other tool that has not been wetted with water, smooth it out.
- Wet tooling: After the material has been put in place, using a spatula or other tool that has been wetted with water, smooth it out.
- Wet tooling: After the material has been installed, lightly mist the material with water. Use a plastic water spray bottle, turn the nozzle to a mist spray orifice, hold the bottle approximately 10-12 inches (255-305mm) from the area. **DO NOT APPLY WATER TO THE MATERIAL IN A CONCENTRATED JET SPRAY.** This will apply too much water, causing the material to dilute and run out.

CAULKING INSTRUCTIONS - GRABBERGARD EFC

Caulking Penetrations

Install the correct amount of caulk material into the opening (annular space) around the service penetration to the depth/thickness required. Make sure that caulking is in intimate contact with the substrate and the penetrating item. Once the caulk is in place, tool the material with a tooling utensil (spatula) to a smooth finish. This will push the installed material into areas not covered in the initial caulking procedure. It will also help to ensure a better bond with mating construction materials.

Caulking Construction Joints

Some construction joints do not require damming material or mineral wool to be used to affect a firestop system. When fillercaulk material is the only component required, the installation must be installed in accordance with the listing being used. This usually requires the filler material to be installed into the gap/joint. Once the caulking has been trowelled or gunned in place, the installed material should be tooled into a smooth finish. Work the material to ensure no voids and air holes are left. This is particularly important when caulking to fireproofing materials. Cured fireproofing is very porous and the caulking must be tooled to it to ensure a tight seal and a secure mating surface system, refer to the procedures described above for the proper installation before applying the filler caulking material.

Note: All installation procedures of firestop caulk materials outlined in the proceeding information are **water-based compounds**.

Grabber Branch Locations

GRABBER Atlanta
Duluth, GA
Phone: 770-813-1332

GRABBER Jacksonville
Jacksonville, FL
Phone: 904-739-2760

GRABBER Northwest
Portland, OR
Phone: 503-467-5001

GRABBER Tampa
Tampa, FL
Phone: 813-249-2281

GRABBER California
Concord, CA
Phone: 925-687-6606

GRABBER Honolulu
Honolulu, HI
Phone: 808-836-1161

GRABBER Los Angeles
Santa Fe Springs, CA
Phone: 562-696-5122

GRABBER Texas
Dallas, TX
Phone: 972-470-9044

GRABBER Canada
Langley, British Columbia
Phone: 604-856-1444

GRABBER Miami
Miami, FL
Phone: 305-820-0975

GRABBER Ohio
Fairfield, OH
Phone: 513-874-9027

GRABBER Utah
Murray, UT
Phone: 801-266-4151

GRABBER Frederick
Frederick, MD 21703-7300
Phone: 301-371-0701

GRABBER Midwest
Maumee, OH
Phone: 419-794-8212

GRABBER Orlando
Orlando, FL
Phone: 407-297-7278

GRABBER Virginia
Chantilly, VA
Phone: 703-631-8770

GRABBER Ft. Myers
Ft. Myers, FL
Phone: 239-278-1888

GRABBER Missouri
Kansas City, MO
Phone: 816-931-8816

GRABBER San Diego
San Diego, CA
Phone: 858-292-6022

Grabber/Scorpion Fasteners
East Windsor, CT
Phone: 860-623-3600

GRABBER Houston
Houston, TX
Phone: 713-545-3918

GRABBER Northeast
Pennsauken, NJ
Phone: 856-662-2525

GRABBER Southeast
Pompano Beach, FL
Phone: 954-971-4730

Grabber Branch Locations

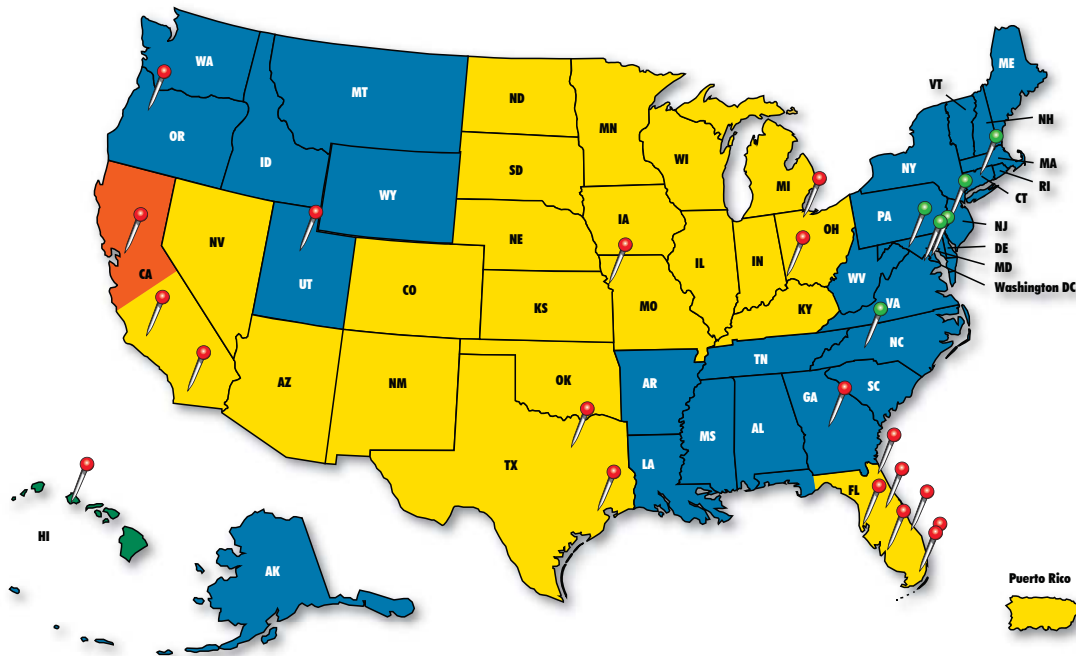

International Division
Phone: 925.687.6606

Home Centers
Phone: 800.606.6006

U.S. North Division
Phone: 800-241-3161

U.S. South Division
Phone: 800-925-0320

Grabber has you covered with more than just great fastening products. . .

To put it simply, Grabber can help you build a better product while simultaneously making you more money. Through constant innovation, Grabber continues to simplify the way you work by providing the best, most technologically advanced products available today.



**Drywall Screws
Metal Framing Screws
Concrete Anchors
Pneumatic Nails**

Fasten it

Grabber has a full line of fasteners for just about any application. From drywall screws to heavy gauge framing screws Grabber has what you need. Grabber invented the drywall screw and changed an entire industry. For the past 40 years Grabber has been the name you can trust for professional grade fasteners.



**SuperDrive
Screw Guns
Chop Saws
Lasers**

Drive it

Grabber's SuperDrive tool is designed to make driving screws faster and more accurate. Along with SuperDrive, Grabber offers many other tools that make your work easier including chop saws, routers, lasers and more.



**Subfloor Adhesives
Drywall Adhesives
Acoustical Sealants
Fire Stopping Caulks**

Caulk it

Grabber offers a complete line of caulks including sound control sealants, subfloor adhesives, drywall adhesives, insulation foam and more. Grabber also offers EFC and IFC fire stopping caulks and sealants.



**NO-COAT® Stick Products
NO-COAT® ULTRAFLEX
HYDROTRIM®
Drywall Tape
Finishing Tools**

Finish it

Grabber has everything you need for finishing your drywall projects. From fiberglass mesh tape and spark perforated drywall tape to the innovative No-Coat® structural drywall system, Grabber has what you need to do the job right.

Quality every step of the way. . . the reason the pros choose Grabber

Grabber sweats the small stuff, and that makes all the difference

The professional's first choice for over 40 years, Grabber premium quality screws are built for performance. Sharper threads mean a better driving experience so Grabber changes thread dies more frequently. Tight recesses mean screws are less likely to cam-out and bit tips will last longer so Grabber changes recess dies more frequently. Consistent heat treating means screw heads will be less likely to pop off, so Grabber heat treats fewer screws at a time ensuring more even heat treatment. These are small things most people don't notice, but they are also small things that make the difference between average fasteners and professional grade fasteners.

Grabber is an international distributor of premium fasteners and fastening systems for wood, metal, and drywall applications in the commercial and residential construction markets. Grabber is home to the Deckmaster® Hidden Fastening System, the patented LOX® Drive System, and the SuperDrive Auto-Feed Fastening System. Grabber also distributes a wide range of proprietary tools and accessories, various equipment, and building materials to the construction industry.

Grabber screws and drywall nails are ICC ES (International Code Council Evaluation Service) evaluated, and engineered to meet or exceed the specifications for use, as prescribed in UBC 1997, IBC 2006, IRC 2006, IBC 2009, and IRC 2009. ASTM reports, approvals, shear, pullout and other technical information is available at www.grabberman.com

Grabber screws and nails are produced in an ISO 9001 and ISO 14001 approved and certified manufacturing environments. Grabber also supports a complete line of US manufactured construction fasteners that meet "Buy American" and the "American Reinvestment and Recovery Act" requirements. GrabberGard® exterior grade coated fasteners are rated for use in ACQ, pressure and fire treated lumber.



GRABBER
CONSTRUCTION PRODUCTS

www.grabberman.com

**Visit www.grabberman.com or
call 800-477-8876
to find a dealer near you.**

