

**Firestop Products & Systems
Submittal Documentation**

- Service Penetrations
- Construction Joints/Gaps

Project:

Contractor:

Installer:

Supplier:

Grabber Construction Products, Inc.
866-237-GRAB(4722)

Distributor:

Table of Contents

Table of Contents	PAGE
Table of Contents	2
General Certificate of Conformance	3
LEEDS Information	
United States LEEDS	5
Product Data Sheets	
GrabberGard EFC	7

Through-Penetrations Firestop Systems

Type of assembly

CFW – Concrete Floors & Walls
 CF – Concrete Floors
 CMD – Concrete Metal Decks
 PCF – Precast Concrete Floors

FF – Framed Floors
 HFS – Hambro Floor Systems
 CW – Concrete Walls
 FW – Framed Walls

Type of Assembly	System #	GrabberGard Product Used	System Details	
CFW	C-AJ-0108	EFC	2 hr - 4-1/2 x 40 or 4-1/2 in. diam void	11
CFW	C-AJ-1499	EFC	3 hr - steel, conduit, iron, copper pipes	12
CFW	C-AJ-1500	EFC	3 hr - steel, conduit, iron, copper pipe w/ metal sleeve	13
CFW	C-AJ-2470	EFC	2 hr - cpvc	15
CFW	C-AJ-3233	EFC	3 hr - multiple cables	16
CFW	C-AJ-5266	EFC	2 hr - ab/pvc insulated metal pipes	17
CFW	C-AJ-5267	EFC	2 hr - fg insulated metal pipes	18
CFW	C-AJ-8145	EFC	2 hr - Multiple elec cables & metal pipes	19
CF	F-A-2126	EFC	2 hr - abs, pvc, w/ wc	21
CF	F-A-7015	EFC	2 hr - 24 in. x 24 in. duct	22
CMD	F-A-7016	EFC	2 hr - 16 in. diam duct	23
FF	F-C-1122	EFC	1 hr - steel, iron, conduit, copper pipes	24
FF	F-C-2287	EFC	1 hr - cpvc, pvc and rnc	25
FF	F-C-3080	EFC	1 & 2 hr - single cable	26
CW	W-J-1157	EFC	1, 2, 3 & 4 hr - steel, iron, conduit, copper pipes	27
CW	W-J-2153	EFC	1, 2, 3 & 4 hr - cpvc, pvc, pex	28
CW	W-J-3123	EFC	1 & 2 hr - multiple cables	29
CW	W-J-4047	EFC	1 & 2 hr - 24 x 6 in. alum or steel cable tray	30
CW	W-J-7066	EFC	1 & 2 hr - 26 x 30 in.; min 24 ga. rectangular duct	72
CW	W-J-7067	EFC	1 & 2 hr - 16 in. min 22 ga round duct	33

Type of Assembly	System #	GrabberGard Product Used	System Details	
FW	W-L-1342	EFC	1, 2, 3 & 4 hr - steel, iron, conduit, copper pipes	34
FW	W-L-2387	EFC	1, 2, 3 & 4 hr - cpvc, pvc, pex	36
FW	W-L-3247	EFC	1 & 2 hr - multiple cables	37
FW	W-L-4047	EFC	1 & 2 hr - 24 x 6 in. alum or steel cable tray	38
FW	W-L-5219	EFC	1 & 2 hr - ab/pvc insulated metal pipes	40
FW	W-L-7109	EFC	1 & 2 hr - 26 x 30 in.; min 24 ga. rectangular duct	42
FW	W-L-7110	EFC	1 & 2 hr - 16 in. min 22 ga round duct	43

Material Data Sheets

GrabberGard EFC. 44

Equipment and Installation

Caulking Instructions GrabberGard EFC 47

Locations

Grabber Branch Locations 54

GENERAL CERTIFICATE OF CONFORMANCE

Grabber Construction Products, Inc.
205 Mason Circle, Concord, CA 94520

GrabberGard EFC, IFC & EFS

THESE PRODUCTS ARE TESTED TO THE FOLLOWING TEST STANDARDS

In the USA:

ASTM E-814 Standard Test Method for Fire Tests of Through Penetrations Fire Stops

ASTM E-1399 Cyclic Movement and Measuring the Minimum and Maximum Joint Widths of Architectural Joint Systems

UL 1479 Fire Tests of Through-Penetration Firestops

UL 2079 Tests for Fire Resistance of Building Joint Systems

In Canada:

ULC S115-M95 Standard Method of Fire Tests of Firestop Systems

TESTED BY THIRD PARTY AGENCIES

Underwriters Laboratories, Inc. (UL)
Intertek Testing Services Inc. – Warnock Hersey (WHI)

No Asbestos or PCBs are used or contained in this product.

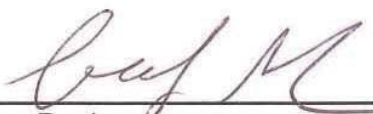

George Rouhana
Executive Director

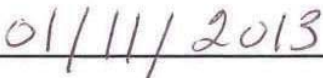

Date



LEED is a trademark of the US Green Building Council

To Whom It May Concern:

Re: LEED Information on Grabber Construction Products' GrabberGard Firestopping Products

This letter will detail the contribution of Grabber Construction Products' GrabberGard firestopping products to the LEED® (Leadership in Energy and Environmental Design) Green Building Rating System® in accordance with LEED-NC Version 2009 For New Construction & Major Renovations.

In reference to LEED® Material and Resource (MR) – Credit 2 – Construction Waste Management – the following Grabber' materials are recyclable where facilities exist:

Packaging	Recyclable Product	Weight Per Unit
Carton	Cardboard	56 g – EBI-60
		70 g – Putty Stick
		190 g – 10 oz plastic tube
		350 g – 20 oz foil package
		410 g – 10 L plastic jar
		600 g – 29 oz plastic tube
10.1 oz (300ml) plastic tube	HDPE	49 g / Tube
20 oz (600ml) foil pack	Aluminum	5 g / Pack
29 oz (850ml) tube	Fiberboard	84 g / Tube
35.2 oz (1L) EZ pour plastic bottle	HDPE	50 g / Bottle
2.5 gallon (9.5L) plastic pai	HDPE	0.8 kg / Pail
2.65 gallon (10 L) plastic jar	HDPE	345 g / Jar
5 gallon (18.9L) plastic pail	HDPE	1.2 kg / Pail
Wooden pallet	Wood	21 kg / Pallet

In reference to LEED® Material and Resources – Credits 4.1 & 4.2 – Recycled Content, all GrabberGard firestopping products contain 5% post-consumer recycled content.

In reference to LEED® Material and Resources – Credit 5 - Regional Materials, Grabber can confirm that a minimum of 50% of the raw materials used in manufacturing the GrabberGard firestopping products are sourced and processed within a 500-miles radius of our manufacturing facility in Vancouver, BC.

If the project site is located within a 500-mile radius of our manufacturing site then this manufacturing site can contribute to earning Materials and Resource Credit 5.1 & 5.2.

The volatile organic content (VOC) of GrabberGard firestopping products are listed below and meets the minimum LEED® requirements for low-emitting materials. These materials can assist to earn Indoor Environmental Quality (IEQ) – Credit 4.1 – Low-Emitting Materials: Adhesives & Sealants (Architectural Sealants) & Credit 4.2 – Low-Emitting Materials: Paints & Coatings (Architectural Sealants).

GrabberGard Firestopping Product	VOC content [g/L]
EFC	32.5
IFC	37.1
EFS	81.3

If you have any additional questions, please feel free to contact us at (800) 237-4722.

PRODUCT DATA SHEET GRABBERGARD EFC

1 of 4

Description

GRABBERGARD EFC is a superior performance latexbased endothermic firestop caulk. It has excellent adhesion and bonding characteristics and will not slump or sag out after it has been properly installed. GRABBERGARD EFC elastomeric caulk has been designed to stop the passage of fires, smoke and fumes through fire-rated assemblies after it has been fully cured. GRABBERGARD EFC is chemically compatible with plastic pipes and cable jackets and is water resistant after fully cured. Once cured Grabbergard EFC provides a durable and flexible firestop and can be repaired if damaged or cut.

Applications

GRABBERGARD EFC firestop caulk provides an effective firestop seal when used as a single or multiple component system for through-penetrations, construction joints and voids. To make certain installation is correct, consult manufacturer's current listings, as well as, Third Party published Fire Resistance Directories and/or their websites. GRABBERGARD EFC common uses and features are listed below:

Used on: Single and multiple penetrations

Metallc pipes

- Copper, steel, cast iron
- Conduits

Non-metallc pipes

- ABS, CPVC, FRPP, PE, PEX, PVC
- Rigid and ENT conduit

Insulated pipes

- Fiberglass
- AB/PVC

Electrical cables and wires

- Jacket & non-jacketed

Cable trays

Mechanical ducts

Construction joints/gaps

- Top-of-Wall
- Horizontal and vertical joints
- Perimeter floor joints

Voids

Common construction substrate materials:

- Concrete
- Concrete block
- Steel deck
- Wood
- Gypsum wallboard

Features: Red Color
Non-toxic
Safe and easy to use
Easy clean up (Water Only)
Low volatile organic content (VOC)
No asbestos or PCB
Water resistance (when fully cured)
Mildew resistant (when fully cured)
Paintable (with latex based paints)
Excellent application characteristics

- Flows easily
- No slump
- Superior bond and adhesion

Excellent acoustic properties
Seals smoke and gases
One-component systems

Advantages

Endothermic — When GRABBERGARD EFC is exposed to high temperatures or direct fire, it releases water vapor, forms a solid char and retards the spread of fire.

Single Component

GRABBERGARD EFC Caulk can be used as a single component firestop in many applications. Just install the caulk directly into the opening without using fibrous insulation materials. In many situations GRABBERGARD EFC will replace the more conventional intumescent firestop devices such as pipe collars and wrap strips. This will reduce both the cost and installation time.

Versatility

GRABBERGARD EFC adheres to dry and damp concrete, wood, metals and other common construction material surfaces to form an air and watertight bond. GRABBERGARD EFC can be painted over using a latexbased paint after fully cured.

Flexibility

When installed GRABBERGARD EFC is properly installed in construction joints it will allow up to 33 percent extension and compression movement of the intersecting assemblies. It will also accommodate longitudinal and lateral movement of through and partial service penetrating items installed in the assembly. GRABBERGARD EFC will remain flexible after it has fully cured.

Disclaimer: All technical advice, recommendations and services rendered by the seller gratis. They are based on technical data, which the seller believes to be reliable, and are intended for use by persons having the skills and know how, at their own discretion and risk. In no event will the seller be liable for any consequential damages arising out of the use of this product.



PRODUCT DATA SHEET GRABBERGARD EFC

2 of 4

Limitations

Consult the Installation Instructions, Storage and Handling and Transportation Sections. Exposure to rain, running or standing water; before, the sealant is cured may cause the installed material(s) to wash out. The curing process occurs naturally through the evaporation of its water content into the atmosphere. Slower cure times may be experienced if the sealant is installed at low temperatures, damp and/or in high humidity environments. Any materials used in the firestop system for damming, insulation or support that may not allow for the free passage of air could result in longer curing times. The environment in which the compound is being used should be considered when estimating cure times.

Compliance/Approvals

GRABBERGARD EFC has been Third Party tested for many firestop applications. They meet or exceed the requirements of ASTM E 814; ASTM E 119; UL 1479; UL 2079; ULC S 115-M95; ULC S 101; ASTM E 84. Underwriters Laboratories (UL) and Intertek Warnock Hersey are Third Party fire endurance testing agencies accredited by ICBO, BOCA, and SBCCI (National Evaluation Services) in the United States.

Additional Testing

GRABBERGARD EFC caulk becomes an integral component in a complete building system of walls, floor/ ceiling assemblies, service penetration, joints and the like. For this reason, its physical compatibility to other materials used in these complex configurations requires more than the routine firestopping product testing. The results of these additional tests are listed in Table 1, Physical and Chemical Properties.

GRABBERGARD EFC caulk has proven that it has all the physical and chemical characteristics desired in a firestopping product. After it has been installed and fully cured, it has excellent stability and flexibility, even after four weeks at freezing temperatures of -15°F (-26°C) and exposure to extreme temperatures of 300 F(149°C) for 24 hours. Dimensional changes were well within the accepted standards (<2% per ASTM C 356). Dynamic testing has demonstrated the high elasticity properties of GRABBERGARD EFC.

Installation Instructions

GRABBERGARD EFC must be installed in compliance with the listed system designs published by Third Party testing laboratories (UL, ITS Warnock Hersey). Refer to their respective published Fire Resistance Directories and/or their Websites. GRABBERGARD EFC does not require mineral wool insulation in many applications.

Prep-work

To install properly, remove excessive dust, dirt, debris, grease, oil and standing water.

Application

Apply caulking material with standard cartridge or bulk-loading application guns or trowel in place with standard troweling tools. Install the required amount of caulking material into the opening using sufficient pressure to ensure it is in contact with all surfaces, substrates and/or penetrating items. The manufacturer recommends tooling the surface with a moist putty knife or similar tooling utensil. Tooling the caulking material will create a stronger bond and a smooth finish especially on irregular or porous surfaces. Do not apply GRABBERGARD EFC to mineral wool that is or was wet from exposure to water, standing water, rain or snow.

Caution: Mineral wool may cause eye, skin or respiratory tract irritation. Avoid contact with eyes, skin of clothing. Recommend using gloves and goggles. Refer to mineral wool manufacturer's Material Safety Data Sheets.

Installation Temperature

For best results, installation temperatures should be between 45°-90°F(7°-32°C).

Maintenance

No special maintenance is required after the GRABBERGARD EFC sealant is installed and fully cured. If, after installation, the GRABBERGARD EFC sealant is damaged or cut, repairs should be made with the same sealant.

Disclaimer: All technical advice, recommendations and services rendered by the seller gratis. They are based on technical data, which the seller believes to be reliable, and are intended for use by persons having the skills and know how, at their own discretion and risk. In no event will the seller be liable for any consequential damages arising out of the use of this product.



PRODUCT DATA SHEET GRABBERGARD EFC

3 of 4

Manufacturer's Recommendations

The manufacturer recommends this product be installed by those trained in proper installation procedures (Approved Installer Card) and be able to read and understand a firestop system design listing (i.e. UL or WHI Listed System Design).

Storage and Handling

Keep product stored in a protected covered area in its original unopened containers. Manufacturer recommends storage temperatures to between 40°-90°F(4°-32°C).

DO NOT ALLOW TO FREEZE

Product has a shelf life of one(1) year. Stock rotation program is recommended.

Transportation

Recommended transportation temperatures should be between 40°-90°F (4°-32°C).

DO NOT ALLOW TO FREEZE**First Aid**

In case of contact with eyes, flush with water and consult a physician. Skin contact, clean up thoroughly with water or soapy water. Consult a physician if eye or skin irritation develops or is persistent. SEE MSDS FOR ADDITIONAL INFORMATION.

Availability

GRABBERGARD EFC caulk is supplied in:

- 10 fl. oz. (300ml) plastic cartridges
- 29 fl. oz. (850ml) cartridges
- 20 fl. oz. (590ml) sausages
- 5 gal. (18.9L) tapered plastic pails

Coverage

Estimated product usage will vary depending on opening size and configuration. Check GRABBERGARD'S estimating charts for coverage.

Warranty

Grabber Construction Products will not accept liability for more than product refund. Any claim regarding product defect must be received in writing within 1 year from date of shipment. Grabber makes no other Warranty or Guarantee express or implied, including warranties of fitness for a particular purpose or merchantability. The seller shall assume no other liability for incidental or consequential damages arising out of the sale or use of this product.

Technical Services

For technical information and assistance regarding application information, code requirements and performance specifications:

Toll Free 1-866-237-GRAB(4722)

Web Site www.grabberman.com

Disclaimer: All technical advice, recommendations and services rendered by the seller gratis. They are based on technical data, which the seller believes to be reliable, and are intended for use by persons having the skills and know how, at their own discretion and risk. In no event will the seller be liable for any consequential damages arising out of the use of this product.



PRODUCT DATA SHEET GRABBERGARD EFC

Table 1 – Physical and Chemical Properties

As Supplied

Type of Polymer	Waterborne Resin
Odor	Mild Latex
Solids Content (Wt%)	77±2%
Application Temperatures	45°-90°F(7°-32°C)
Viscosity (ASTM D-2196)	560000-744000cps
Extrudability	Passed
Color - (ASTM C-834)	Rust Red
Specific Gravity - (ASTM D-1475)	1.40-1.50
Dry Time - (ASTM D-1640)	
Dry to touch @ 6mils	20-30 mins
Full Cure Time	7-21 days
(depends on thickness & environment)	
pH - (ASTM E-70)	8-9

As Cured

In Service Temperature	up to 120°F(49°C)
Moisture Absorption	< 4%
Stability	Passed
[Dimensional, Cracking, Blisters, Flexibility]	
Corrosion - (ASTM C-655)	Passed
[for Aluminum, Copper, Steel, Galvanized Steel, Stainless Steel]	
Volume Shrinkage - (ASTM C-1241)	Passed
Chemical Compatibility - (ASTM D-543)	Passed
Slump Test - (ASTM D-2202 - Modified)	Passed
Hardness - (ASTM D-2240, Shore A)	22
Freeze/Thaw - (ASTM D-2243)	Excellent
Tensile Properties - (ASTM D-2370)	
Tensile Strength	26 psi
Maximum Elongation	1400%
Corrosion - (ASTM D-5894)	Passed
Surface Burning Characteristics - (ASTM E-84)	
Flame Spread Index	< 25
Smoke Developed Index	< 50
STC Sound Transmission Loss - (ASTM 90-99)	Full Recovery

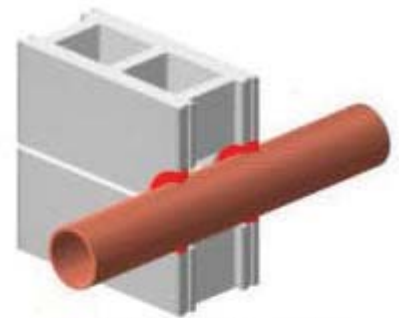

Typical Pipe Penetration

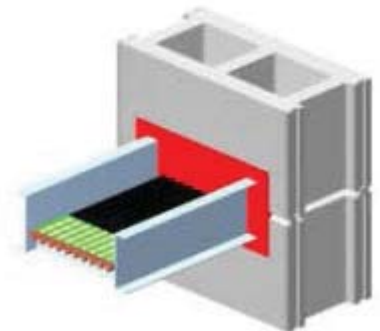

Typical Cable Tray Penetration

Disclaimer: All technical advice, recommendations and services rendered by the seller gratis. They are based on technical data, which the seller believes to be reliable, and are intended for use by persons having the skills and know how, at their own discretion and risk. In no event will the seller be liable for any consequential damages arising out of the use of this product.



System No. C-AJ-0108

F Rating – 2 Hr

T Rating – 2 Hr

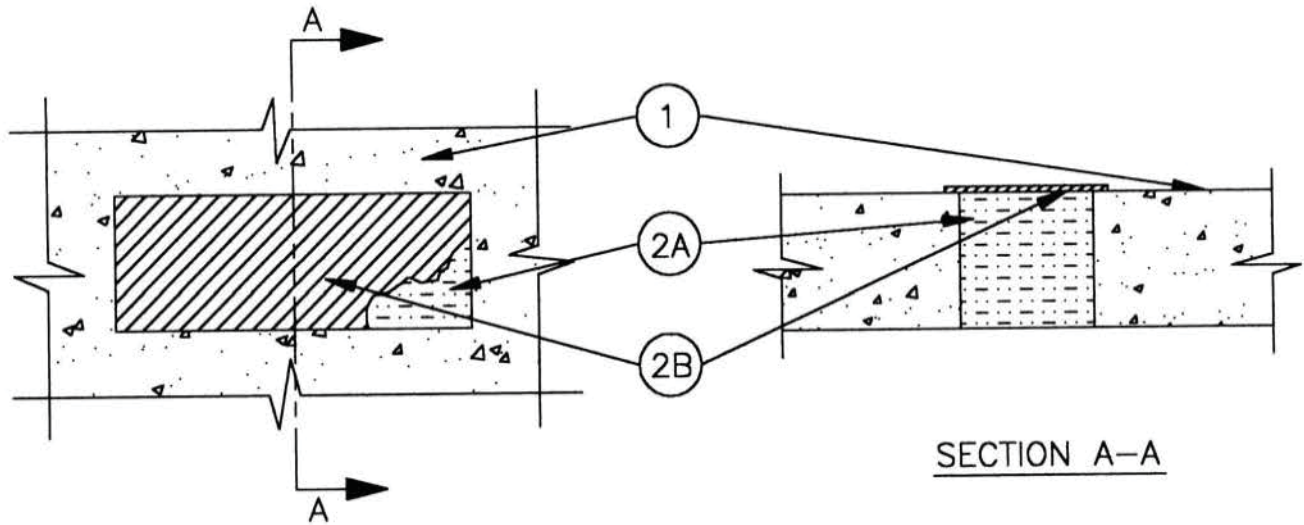

1. **Floor or Wall Assembly** – Min 4-1/2 in. thick reinforced lightweight or normal weight (100-150 pcf) structural concrete. Min 5 in. thick reinforced lightweight or normal weight (100-150 pcf) structural concrete wall. Wall may also be constructed of any UL Classified Concrete Blocks*. Max size of opening to be 4-1/2 by 40 in. or 4-1/2 in diam.

A. See **Concrete Blocks (CAZT)** category in the Fire Resistance Directory for names of manufactures.

2. **Firestop System** – The firestop system shall consist of the following:

A. **Packing Material** – Min 4 in. or 4-1/2 in. thickness of min 4 pcf mineral wool batt insulation for sealants B1 and B2, respectively, compressed 25 percent into opening as a permanent form. Packing material to be recessed from top surface of floor or both surfaces of wall assembly to accommodate the required thickness of fill material (Item 2B1).

B. **Fill, Void or Cavity Material* – Sealant** – Min 1/2 in. thickness of fill material applied within the opening, flush with top surface of floor or both surfaces of wall assembly.

GRABBER CONSTRUCTION PRODUCTS INC – GrabberGard EFC

*Bearing the UL Classification Marking



System No. C-AJ-1499

L Rating at Ambient – Less than 1 CFM/ sq. ft.

L Rating at 400°F – Less than 1 CFM/sq. ft.

F Rating – 3 Hr

T Rating – 1/4 Hr

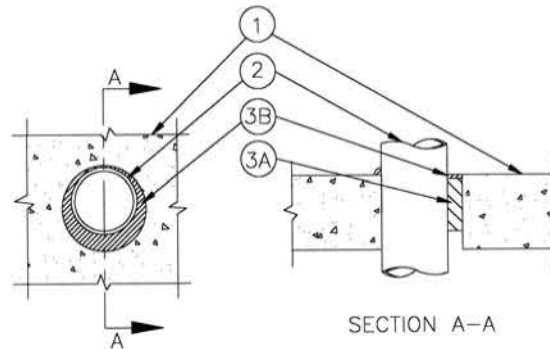

1. **Floor or Wall Assembly** – Min 4-1/2 in. thick lightweight or normal weight (100-150 pcf) concrete. Wall may also be constructed of any UL Classified Concrete Block. Max diam of opening is 25-1/4 in.
See **Concrete Blocks (CAZT)** category in the Fire Resistance Directory for names of manufacturers.
2. **Through Penetrants** – One metallic pipe, conduit or tubing to be installed either concentrically or eccentrically within the firestop system. The annular space between pipe, conduit or tubing and edge of through opening shall be min 0 in. (point contact) to max 2-1/8 in. Pipe, conduit or tubing to be rigidly supported on both sides of floor or wall assembly. The following types and sizes of metallic pipes, conduits or tubing may be used:
 - A. **Steel Pipe** – Nom 24 in. diam (or smaller) Schedule 10 (or heavier) steel pipe.
 - B. **Conduit** – Nom 6 in. diam (or smaller) rigid steel conduit.
 - C. **Conduit** – Nom 4 in. diam (or smaller) steel electrical metallic tubing.
 - D. **Iron Pipe** – Nom 24 in. diam (or smaller) cast or ductile iron pipe.
 - E. **Copper Tubing** – Nom 6 in. diam (or smaller) Type L (or heavier) copper tube.
 - F. **Copper Pipe** – Nom 6 in. diam (or smaller) Regular (or heavier) copper pipe.
3. **Firestop System** – The firestop system shall consist of the following:
 - A. **Packing Material** – Min 4 in. or 4-1/2 in. thickness of 4 pcf mineral wool batt insulation for sealants B1 and B2, respectively, firmly packed into opening as a permanent form. Packing material to be recessed from top surface of floor or from both surfaces of wall to accommodate the required thickness of fill material (Item 3B).
 - B. **Fill Void or Cavity Material*** – Sealant – Min 1/2 in. thickness of fill material applied within annulus, flush with top surface of floor or both surfaces of wall. At point contact location between penetrant and periphery of opening a min 1/2 in. diam bead of fill material shall be applied at the periphery of opening/penetrant interface on top surface of floor assembly or both surfaces of wall.

GRABBER CONSTRUCTION PRODUCTS INC – GrabberGard EFC

*Bearing the UL Classification Marking





System No. C-AJ-1500

L Rating at Ambient – Less than 1 CFM/ sq. ft.

L Rating at 400°F – Less than 1 CFM/sq. ft.

F Rating – 3 Hr

T Rating – 1/4 Hr

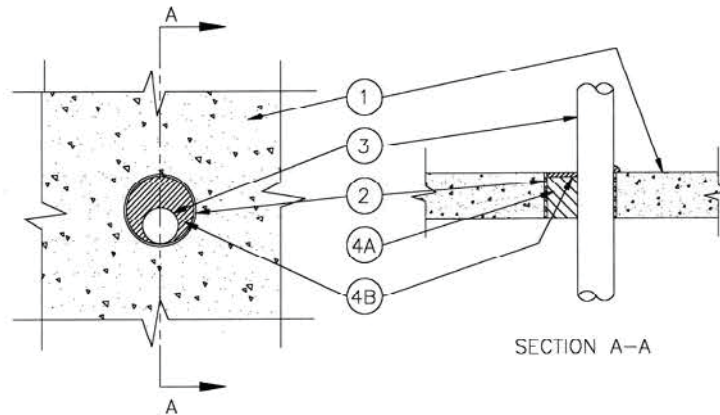

1. **Floor or Wall Assembly** – Min 4-1/2 in. thick lightweight or normal weight concrete (100-150 pcf). Wall may also be constructed of any UL Classified **Concrete Blocks***. Max diam of opening is 8 in.
See **Concrete Blocks (CAZT)** category in the Fire Resistance Directory for names of manufacturers.
2. **Metallic Sleeve** – (Optional) – Sleeve to be cast or grouted into floor or wall assembly, flush with floor or both wall assembly. The following metallic sleeves may be used within the firestop system:
 - A. Nom 8 in. diam (or smaller) Schedule 40 (or heavier) steel sleeve.
 - B. Nom 4 in. diam (or smaller) steel electrical metallic tubing (EMT) sleeve.
3. **Through Penetrants** – One metallic pipe, conduit or tubing to be installed either concentrically or eccentrically within the firestop system. The annular space between pipe, conduit or tubing and sleeve or periphery of opening shall be min 0 in. (point contact) to max 3-1/2 in. Pipe, conduit or tubing to be rigidly supported on both sides of floor or wall assembly. The following types and sizes of metallic pipes, conduits or tubing may be used:
 - A. **Steel Pipe** – Nom 4 in. diam (or smaller) Schedule 40 (or heavier) steel pipe.
 - B. **Iron Pipe** – Nom 4 in. diam (or smaller) cast or ductile iron pipe.
 - C. **Conduit** – Nom 4 in. diam (or smaller) steel electrical metallic tubing or rigid steel conduit.
 - D. **Copper Tubing** – Nom 3 in. diam (or smaller) Type L (or heavier) copper tube.
 - E. **Copper Pipe** – Nom 3 in. diam (or smaller) Regular (or heavier) copper pipe.





4. **Firestop System** – The firestop system shall consist of the following:

- A. **Packing Material** – Min 4 in. or 4-1/4 in. thickness of min 4 pcf density mineral wool batt insulation for sealants B1 and B2, respectively, firmly packed into opening as a permanent form. Packing material to be recessed from top surface of floor or from both surfaces of wall as required to accommodate the required thickness of fill material (Item 4B).
- B. **Fill Void or Cavity Material* – Sealant** – Min 1/2 in. thickness of fill material applied within annulus, flush with top surface of floor or both surfaces of wall. At point contact location between penetrant and sleeve or concrete, a 1/2 in. diam bead of fill material shall be applied at the sleeve or concrete/penetrant interface on the top surface of floor or both surfaces of wall.

GRABBER CONSTRUCTION PRODUCTS INC – GrabberGard EFC

*Bearing the UL Classification Marking





System No. C-AJ-2470

F Rating - 2 Hr
T Rating - 2 Hr

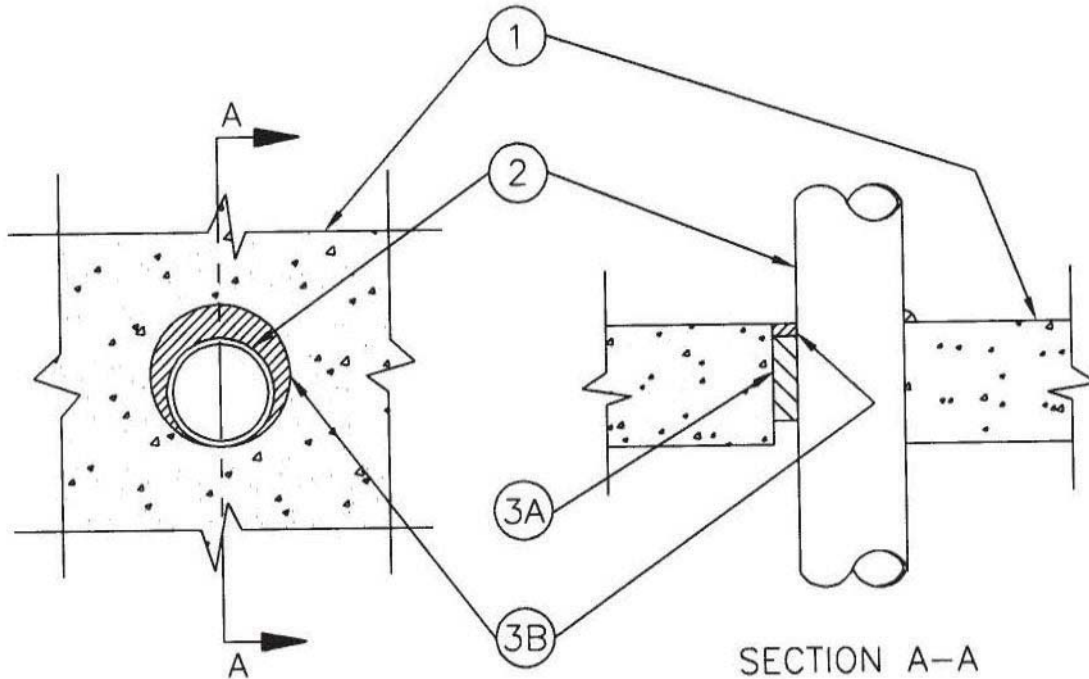

1. **Floor or Wall Assembly** – Min 5 in. thick normal weight (150 pcf) concrete. Wall may also be constructed of any UL Classified Concrete Blocks*. Max diam of opening is 3-3/4 in.
See **Concrete Blocks (CAZT)** category in the Fire Resistance Directory for names of manufacturers.
2. **Nonmetallic Pipe** – Nom 2 in. diam (or smaller) SDR 11 chlorinated polyvinyl chloride (CPVC) pipe for use in closed (process or supply) piping systems. One pipe to be installed either concentrically or eccentrically within the firestop system. The annular space between pipe and periphery of opening shall be min 3/8 in. to max 1 in. Pipe to be rigidly supported on both sides of floor or wall assembly.
3. **Firestop System** – The firestop system shall consist of the following:
 - A. **Packing Material** – Min 3-1/2 in. thickness of min 4 pcf mineral wool batt insulation firmly packed into opening as a permanent form. Packing material to be recessed from top surface of floor or from both surfaces of wall as required to accommodate the required thickness of fill material (Item 3B).
 - B. **Fill, Void or Cavity Material* – Sealant** – Min 1/2 in. thickness of fill material applied within annulus, flush with top surface of floor or both surfaces of wall.

GRABBER CONSTRUCTION PRODUCTS INC – GrabberGard EFC

*Bearing the UL Classification Marking





System No. C-AJ-3233

F Rating - 3 Hr
T Rating - 1/2 Hr

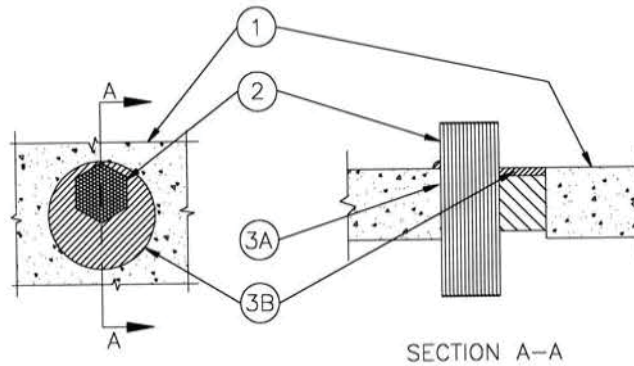

1. **Floor or Wall Assembly** — Min 5 in. thick normal weight (150 pcf) concrete. Wall may also be constructed of any UL Classified **Concrete Blocks***. Max diam of opening is 10-1/4 in.

See **Concrete Blocks (CAZT)** category in the Fire Resistance Directory for names of manufacturers.

2. **Cables** — Aggregate cross-sectional area of cable in opening to be max 27 percent of the cross-sectional area of the opening. The annular space between cables and periphery shall be min 0 in. (point contact) to max 3-1/2 in. Cables to be rigidly supported on both sides of floor or wall assembly. Any combination of the following types and sizes of copper conductor cables may be used:

- A. 1/C 750 kcmil (or smaller) copper conductor polyvinyl chloride (PVC) jacketed aluminum clad or steel clad TEK cable with cross-linked polyethylene (XLPE) insulation.
- B. 3/C 350 kcmil (or smaller) copper conductor PVC jacketed aluminum clad or steel clad TEK cable with XLPE insulation.
- C. 4/C No. 14 AWG (or smaller) copper conductor PVC jacketed aluminum clad or steel clad TEK cable with XLPE insulation.
- D. Max 25 pair No. 20 AWG (and smaller) copper conductor PVC jacketed cable with PVC insulation.
- E. 1/C 400 kcmil (or smaller) aluminum or copper conductor cable with XLPE insulation.
- F. 4/C No. 6 AWG (or smaller) copper conductor PVC jacketed cable with XLPE insulation
- G. **Through Penetration Product*** — Max 3/C No. 2 AWG (or smaller) aluminum or steel clad **Armored Cable** or aluminum or steel clad **Metal Clad Cable** with copper conductors.

ALFEX CORP

3. **Firestop System** — The firestop system shall consist of the following:

- A. **Packing Material** — Min 3-1/2 in thickness of min 4 pcf mineral wool batt insulation firmly packed into opening as a permanent form. Packing material to be recessed from top surface of floor or from both surfaces of wall as required to accommodate the required thickness of fill material (Item 3B).
- B. **Fill, Void or Cavity Material* — Sealant** — Min 1/2 in. thickness of fill material applied within annulus, flush with top surface of floor or both surfaces of wall. Sealant to be forced into interstices of cable group to max extent possible.

GRABBER CONSTRUCTION PRODUCTS INC — GrabberGard EFC

*Bearing the UL Classification Marking





System No. C-AJ-5266

F Rating - 2 Hr

T Rating - 3/4 & 1-1/4 Hr (See Item 2)

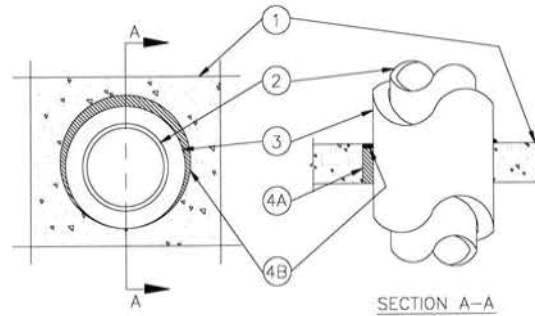

1. **Floor or Wall Assembly** – Min 4-1/2 in. thick reinforced lightweight or normal weight (100-150 pcf) concrete. Wall may also be constructed of any UL Classified **Concrete Blocks***. Max diam of opening is 18 in.
See **Concrete Blocks (CAZT)** category in the Fire Resistance Directory for names of manufacturers.
2. **Through Penetrants** – One metallic pipe or tubing to be installed either concentrically or eccentrically within the firestop system. Pipe or tubing to be rigidly supported on both sides of floor or wall assembly. The following types and sizes of metallic pipes or tubing may be used:
 - A. **Steel Pipe** – Nom 12 in. diam (or smaller) Schedule ST 40 (or heavier) steel pipe.
 - B. **Iron Pipe** – Nom 12 in. diam (or smaller) cast or ductile iron pipe.
 - C. **Copper Tubing** – Nom 2 in. diam (or smaller) Type L (or heavier) copper tubing.
 - D. **Copper Pipe** – Nom 2 in. diam (or smaller) Regular (or heavier) copper pipe.
3. **Pipe Covering*** – Max 2 in. thick hollow cylindrical heavy density glass fiber units jacketed on the outside with an all service jacket. Longitudinal joints sealed with metal fasteners or factory-applied self-sealing lap tape. Transverse joints secured with metal fasteners or with butt tape supplied with the product. The annular space between the insulated pipe and the edge of the through opening shall be min 0 in. (point contact) to max 1-1/4 in.
See Pipe and Equipment Covering – **Materials (BRGU)** category in the Building Materials Directory for names of manufacturers. Any pipe covering material meeting the above specifications and bearing the UL Classification Marking with a Flame Spread Index of 25 or less and a Smoke Developed Index of 50 or less may be used.
4. **Firestop System** – The firestop system shall consist of the following:
 - A. **Packing Material** – Min 4 in. thickness of min 4 pcf mineral wool batt insulation firmly packed into opening as a permanent form. Packing material to be recessed from top surface of floor or from both surfaces of wall as required to accommodate the required thickness of fill material.
 - B. **Fill, Void or Cavity Material* – Sealant** – Min 1/2 in. thickness of fill material applied within the annulus, flush with top surface of floor or with both surfaces of wall. At the point contact location between pipe and concrete, a min 3/8 in. diam bead of fill material shall be applied at the concrete/pipe-covering interface on the top surface of floor and on both surfaces of wall.

GRABBER CONSTRUCTION PRODUCTS INC – GrabberGard EFC

*Bearing the UL Classification Marking





System No. C-AJ-5267

F Rating - 2 Hr

T Rating - 3/4 & 1-1/4 Hr (See Item 2)

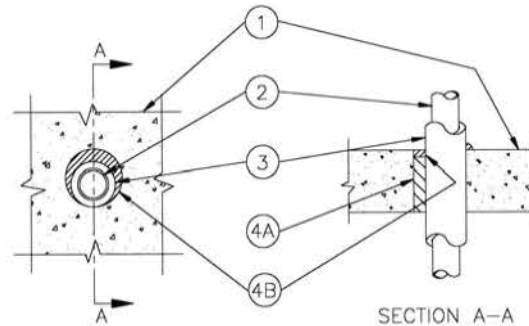

1. **Floor or Wall Assembly** – Min 4-1/2 in. thick reinforced lightweight or normal weight (100-150 pcf) concrete. Wall may also be constructed of any UL Classified Concrete Blocks*. Max diam of opening is 4-1/2 in.
See Concrete Blocks (CAZT) category in the Fire Resistance Directory for names of manufacturers.
2. **Through Penetrants** – One metallic pipe or tubing to be installed either concentrically or eccentrically within the firestop system. Pipe or tubing to be rigidly supported on both sides of floor or wall assembly. The following types and sizes of metallic pipes or tubing may be used:
 - A. **Steel Pipe** – Nom 2 in. diam (or smaller) Schedule ST 40 (or heavier) steel pipe.
 - B. **Iron Pipe** – Nom 2 in. diam (or smaller) cast or ductile iron pipe.
 - C. **Copper Tubing** – Nom 2 in. diam (or smaller) Type L (or heavier) copper tubing.
 - D. **Copper Pipe** – Nom 2 in. diam (or smaller) Regular (or heavier) copper pipe.

T Rating is 1-1/4 Hr for penetrants A, B. T Rating is 3/4 Hr for penetrants C and D.
3. **Tube Insulation – Plastics+** – Nom 3/4 in. thick acrylonitrile butadiene/polyvinyl chloride (AB/PVC) flexible foam furnished in the form of tubing. The annular space between the insulated pipe and the edge of the through opening shall be min 0 in. (point contact) to max 7/8 in.
See Plastics+ (QMFZ2) category in the Recognized Component Directory for names of manufacturers. Any Recognized Component tube insulation material meeting the above specifications and having a UL 94 Flammability Classification of 94-5VA may be used.
4. **Firestop System** – The firestop system shall consist of the following:
 - A. **Packing Material** – Min 4 in. thickness of min 4 pcf mineral wool batt insulation firmly packed into opening as a permanent form. Packing material to be recessed from top surface of floor or from both surfaces of wall as required to accommodate the required thickness of fill material.
 - B. **Fill, Void or Cavity Material* – Sealant** – Min 1/2 in. thickness of fill material applied within the annulus, flush with top surface of floor or with both surfaces of wall.

GRABBER CONSTRUCTION PRODUCTS INC – GrabberGard EFC

+ Bearing the UL Recognized Component Mark

*Bearing the UL Classification Marking





System No. C-AJ-8145

F Rating - 2 Hr

T Rating - 0 Hr

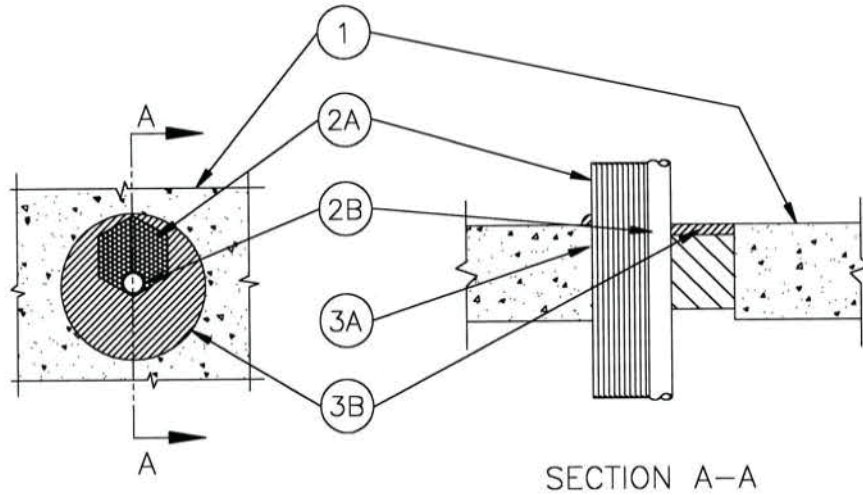

1. **Floor or Wall Assembly** — Min 5 in. thick lightweight or normal weight (100-150 pcf) concrete. Wall may also be constructed of any UL Classified **Concrete Blocks***. Max diam of opening is 10-1/4 in.
See **Concrete Blocks (CAZT)** category in the Fire Resistance Directory for names of manufacturers.

2. **Through Penetrants** — Pipes, conduits or cables to be bundled within the opening such that the aggregate cross-sectional area of penetrants in opening to be max 27 percent of the cross-sectional area of the opening in floor or wall. The space between penetrants and periphery of opening shall be min 0 in. (point contact) to max 3-1/2 in. Penetrants to be rigidly supported on both sides of floor or wall assembly. The following types and sizes of penetrants may be used:

A. **Metallic Pipes** — The following types and sizes of metallic pipes, conduits or tubing may be used:

- A1. **Steel Pipe** — Nom 2 in. diam (or smaller) Schedule 5 (or heavier) steel pipe.
- A2. **Conduit** — Nom 2 in. diam (or smaller) steel electrical metallic tubing or steel conduit.

B. **Cables** — Any combination of the following types and sizes of cables may be used:

- B1. 1/C 750 kcmil (or smaller) copper conductor polyvinyl chloride (PVC) jacketed aluminum clad or steel clad TEK cable with cross-linked polyethylene (XLPE) insulation.
- B2. 3/C 350 kcmil (or smaller) copper conductor PVC jacketed aluminum clad or steel clad TEK cable with XLPE insulation.
- B3. 4/C No. 14 AWG (or smaller) copper conductor PVC jacketed aluminum clad or steel clad TEK cable with XLPE insulation.
- B4. Max 25 pair No. 20 AWG (and smaller) copper conductor PVC jacketed cable with PVC insulation.
- B5. 1/C 400 kcmil (or smaller) aluminum or copper conductor cable with XLPE insulation.
- B6. 4/C No. 6 AWG (or smaller) copper conductor PVC jacketed cable with XLPE insulation.





3. **Firestop System** – The firestop system shall consist of the following:

- A. **Packing Material** – Min 3-1/2 in. thickness of min 4 pcf mineral wool batt insulation firmly packed into opening as a permanent form.
Packing material to be recessed from top surface of floor or from both surfaces of wall as required to accommodate the required thickness of fill material (Item 3B).
- B. **Fill, Void or Cavity Material* – Sealant** – Min 1/2 in. thickness of fill material applied within annulus, flush with top surface of floor or both surfaces of wall. Sealant to be forced into interstices of penetrants to max extent possible.

GRABBER CONSTRUCTION PRODUCTS INC – GrabberGard EFC

*Bearing the UL Classification Marking





System No. F-A-2126

F Rating – 2 Hr

T Rating – 2 Hr

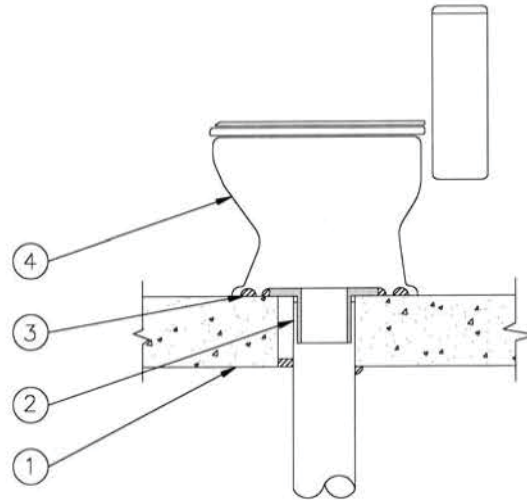

1. **Floor Assembly** – Min 4-1/2 in. thick lightweight or normal weight concrete (100-150 pcf). Max diam of opening is 6 in.
2. **Nonmetallic Pipe** – One nonmetallic drain pipe with max 4 in. diam toilet flange installed either concentrically or eccentrically within the firestop system. The annular space between drain pipe and periphery of opening shall be min 0 in. (point contact) to max 1-1/2 in. Pipe to be rigidly supported on lower side of floor assembly. The following types and sizes of nonmetallic pipes, fittings and flanges may be used:
 - A. **Polyvinyl Chloride (PVC) Pipe** – Nom 4 in. diam (or smaller) Schedule 40 solid core or cellular core PVC pipe for use in vented (drain, waste or vent) piping system.
 - B. **Acrylonitrile Butadiene Styrene (ABS) Pipe** – Nom 4 in. diam (or smaller) Schedule 40 cellular core or solid core ABS pipe for use in vented (drain, waste or vent) piping systems.
3. **Fill, Void or Cavity Material* – Sealant** – Min 1 in. thickness of fill material applied within the annulus, flush with bottom surface of floor. At point contact location between concrete and pipe, a min 1/2 in diam bead of fill material shall be applied at the pipe/concrete interface on bottom surface of floor assembly. A min 1/2 in. diam bead of fill material shall be applied around top edge of toilet flange. Prior to placement of water closet, a min 1/2 in. diam bead of fill material shall be applied to the bottom surface of the outer rim of the water closet.

GRABBER CONSTRUCTION PRODUCTS INC – GrabberGard EFC

4. **Water Closet** – Floor mounted vitreous china water closet.

*Bearing the UL Classification Marking





System No. F-A-7015

F Rating – 2 Hr
T Rating – 1/2 Hr

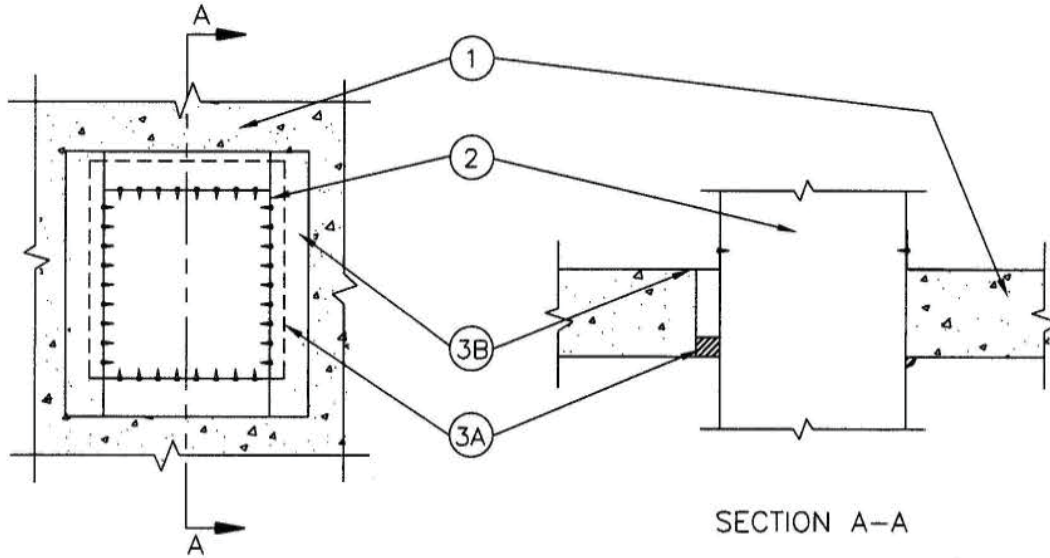

1. **Floor Assembly** – Min 4-1/2 in. thick reinforced lightweight or normal weight (100-150 pcf) concrete. Max area of opening is 625 sq in. with a max dimension of 25 in.
2. **Through Penetrant** – Nom 24 by 24 in. (or smaller) 26 ga. (or heavier) square steel duct to be installed either concentrically or eccentrically within the firestop system. An annular space of min 0 in. (point contact) to max 1 in. Duct to be rigidly supported on top surface of floor assembly.
3. **Firestop System** – The firestop system shall consist of the following:
 - A. **Fill, Void or Cavity Material* – Sealant** – Min 1 in. thickness of fill material applied within annulus, flush with bottom surface of floor. At the point contact location between penetrant and periphery of opening, min 1/2 in. diam bead of fill material shall be applied at the concrete/duct interface on exposed surface of floor.
 - B. **Retaining Angles** – Min 16 gauge 1-1/2 in. by 1-1/2 in. galv steel angles. Angles attached to duct on unexposed side of floor with min 1/2 in. long, No. 8 (or larger) sheet metal screws, spaced max 4 in. OC.

GRABBER CONSTRUCTION PRODUCTS INC – GrabberGard EFC

*Bearing the UL Classification Marking





System No. F-A-7016

F Rating – 2 Hr
T Rating – 1/2 Hr

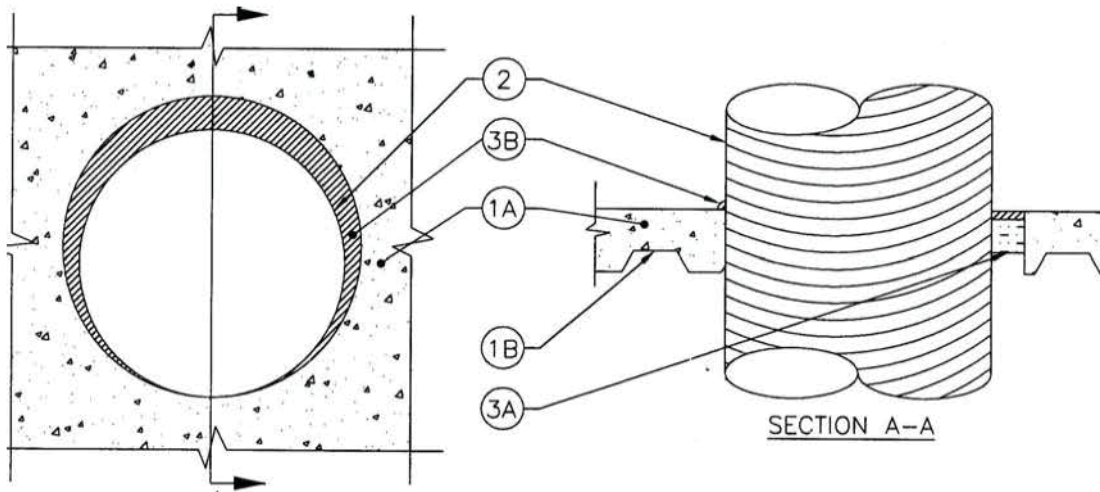

1. **Floor Assembly** – The fire-rated unprotected concrete and steel floor assembly shall be constructed of the materials and in the manner described in the individual D900 Series Floor -Ceiling Design in the UL Fire Resistance Directory and shall include the following construction features:
 - A. **Concrete** – Min 2-1/2 in. thick reinforced lightweight or normal weight (100-150 pcf) concrete.
 - B. **Steel Floor and Form Units*** – Composite or non-composite max 3 in. deep fluted galv units as specified in the individual Floor-Ceiling design. Max diam of opening is 18 in.
2. **Steel Duct** – Nom 16 in. diam (or smaller) No. 22 gauge (or heavier) spiral wound steel duct to be installed either concentrically or eccentrically within the firestop system. The annular space between the duct and the periphery of the opening shall be min. 0 in. (point contact) to max 2 in. Duct to be rigidly supported on both sides of floor assembly.
3. **Firestop System** – The firestop system shall consist of the following:
 - A. **Packing Material** – Min 2 in. thickness of min 4 pcf density mineral wool batt insulation firmly packed into opening as a permanent form. Packing material to be recessed from top surface of floor as required to accommodate required thickness of fill material.
 - B. **Fill, Void or Cavity Material* – Sealant** – Min 1/2 in. thickness of sealant applied within the annulus, flush with top surface of floor. Min 1/2 in. diam bead of sealant shall be applied at the duct/concrete interface at point contact location on the top surface of floor.

GRABBER CONSTRUCTION PRODUCTS INC – GrabberGard EFC

*Bearing the UL Classification Marking





System No. F-C-1122

F Rating – 1 Hr
T Rating – 1/4 Hr

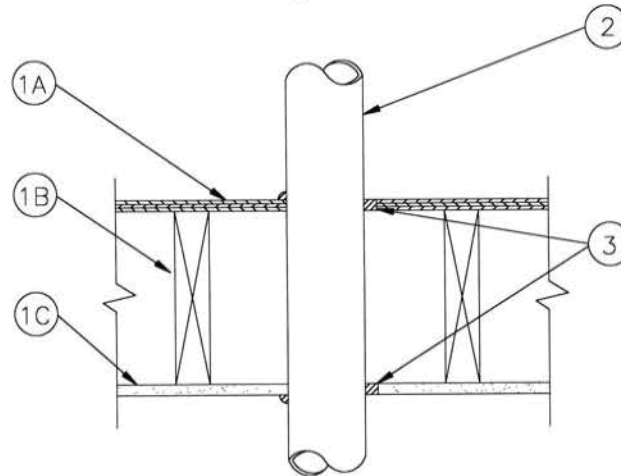

1. **Floor-Ceiling Assembly** – The fire rated wood truss or combination wood and steel truss Floor-Ceiling assembly shall be constructed of the materials and in the manner described in the individual L500 Series Design in the UL Fire Resistance Directory and shall include the following construction features:
 - A. **Flooring System** – Lumber of plywood subfloor with finish floor of lumber, plywood or Floor Topping Mixture-* as specified in the individual Floor-Ceiling Design. Max diam of floor opening is 5-1/8 in.
 - B. **Wood Joists*** – Nom 2 by 10 in. deep (or deeper) lumber joists spaced 16 in. OC with nom 1 by 3 in. lumber bridging and with ends firestopped or steel or combination lumber and steel joists, trusses or Structural Wood Members* with bridging as required and with ends firestopped.
 - C. **Gypsum Board*** – Nom 5/8 in. thick as specified in the individual Floor-Ceiling Design.
2. **Through Penetrants** – One metallic pipe, conduit or tubing to be installed concentrically or eccentrically within the firestop system, The annular space between pipe, conduit or tubing and periphery of opening shall be min 1/4 in. to max 3/4 in. Pipe, conduit or tubing to be rigidly supported on both sides of floor assembly. The following types and sizes of metallic pipe, conduit or tubing may be used:
 - A. **Steel Pipe** – Nom 4 in. diam (or smaller) Schedule 10 (or heavier) steel pipe.
 - B. **Conduit** – Nom 4 in. diam (or smaller) electrical metallic tubing (EMT) or steel conduit.
 - C. **Copper Tubing** – Nom 4 in. diam (or smaller) Type L (or heavier) copper tubing.
 - D. **Copper Pipe** – Nom 4 in. diam (or smaller) Regular (or heavier) copper pipe
 - E. **Iron Pipe** – Nom 4 in. diam (or smaller) service weight (or heavier) cast iron soil pipe, nom 4 in. (or smaller) or Class 50 (or heavier) ductile iron pressure pipe.
3. **Fill, Void or Cavity Material*** – **Sealant** – Min 3/4 in. thickness of fill material applied within the annulus, flush with top surface of floor. Min 5/8 in. applied within the annulus, flush with the surface of ceiling.

GRABBER CONSTRUCTION PRODUCTS INC – GrabberGard EFC

*Bearing the UL Classified Marking





System No. F-C-2287

F Rating – 1 Hr
T Rating – 1 Hr

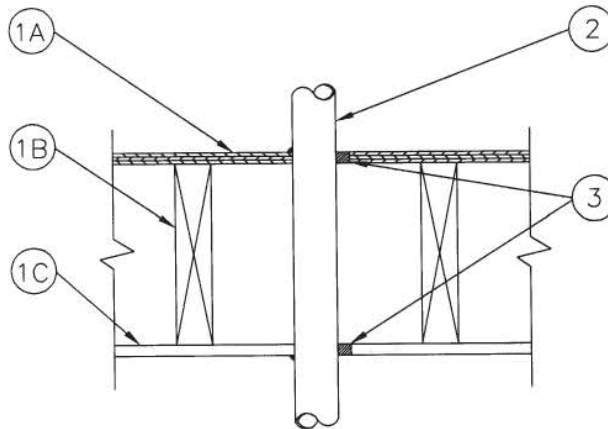

1. **Floor-Ceiling Assembly** – The fire rated wood truss or combination wood and steel truss Floor-Ceiling assembly shall be constructed of the materials and in the manner described in the individual L500 Series Design in the UL Fire Resistance Directory and shall include the following construction features:
 - A. **Flooring System** – Lumber of plywood subfloor with finish floor of lumber, plywood or Floor Topping Mixture* as specified in the individual Floor-Ceiling Design. Max diam of floor opening is 3-1/8 in.
 - B. **Wood Joists*** – Nom 2 by 10 in. deep (or deeper) lumber joists spaced 16 in. OC, with nom 1 by 3 in. lumber bridging and with ends firestopped or steel or combination lumber and steel joists, trusses or Structural Wood Members* with bridging as required and with ends firestopped.
 - C. **Gypsum Board*** – Nom 5/8 in. thick as specified in the individual Floor-Ceiling Design. Max diam of opening is 3-1/8 in.
2. **Through Penetrant** – One non-metallic pipe or conduit to be installed either concentrically or eccentrically within the firestop system. The annular space between pipe and periphery of opening shall be min 0 in. (point contact) to max 7/8 in. Pipe to be rigidly supported on both sides of floor assembly.
 - A. **Chlorinated Polyvinyl Chloride (CPVC) Pipe** – Nom 2 in. diam (or smaller) SDR 11 cellular or solid core chlorinated polyvinyl chloride (CPVC) pipe for use in closed (process or supply) piping systems.
 - B. **Polyvinyl Chloride (PVC) Pipe** – Nom 2 in. diam (or smaller) Schedule 40 (or heavier) PVC pipe for use in closed (process or supply) piping systems.
 - C. **Rigid Nonmetallic Conduit+** – Nom 2 in. diam (or smaller) Schedule 40 PVC conduit installed in accordance with Article 347 of the National Electrical Code (NFPA No. 70).
3. **Fill, Void or Cavity Material*** – **Sealant** – Min 3/4 in. thickness of fill material applied within the annulus, flush with top surface of floor. Min 5/8 in. thickness of fill material applied within the annulus, flush with bottom surface of ceiling. Min 1/4 in. diam bead of fill material applied at the pipe/floor and pipe/ceiling interfaces at point contact locations on both sides of assembly.

GRABBER CONSTRUCTION PRODUCTS INC – GrabberGard EFC

*Bearing the UL Classification Marking

+ Bearing the UL Listing Mark





System No. F-C-3080

F Rating – 1 Hr
T Rating – 1 Hr

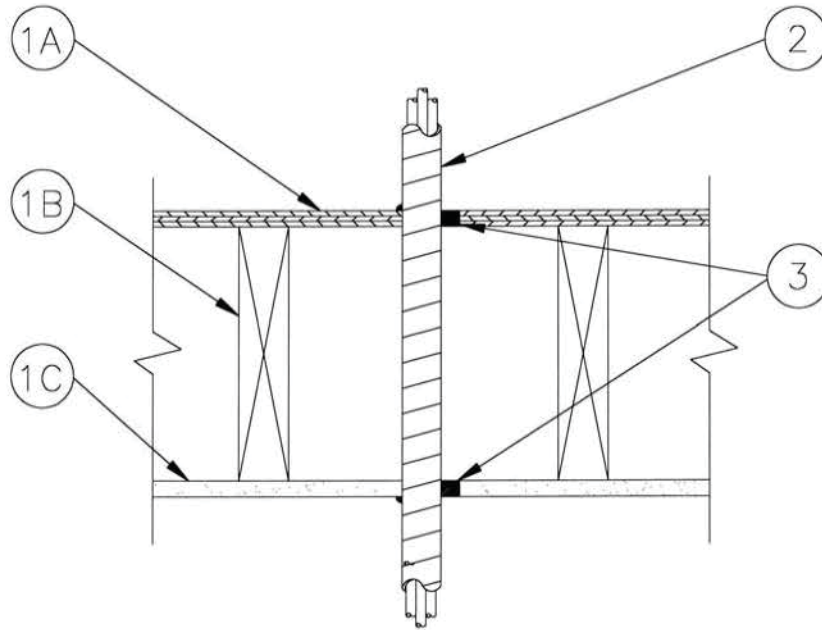

1. **Floor-Ceiling Assembly** – The 1 hr fire rated wood truss or combination wood and steel truss floor-ceiling assembly shall be constructed of the materials and in the manner described in the individual L500 Series Design in the UL Fire Resistance Directory and shall include the following construction features:
 - A. **Flooring System** – Lumber of plywood subfloor with finish floor of lumber, plywood or Floor Topping Mixture* as specified in the individual Floor-Ceiling Design. Max diam of opening is 5-1/8 in.
 - B. **Wood Joists*** – Nom 2 by 10 in. deep (or deeper) lumber joists spaced 16 in. OC with nom 1 by 3 in. lumber bridging and with ends firestopped or steel or combination lumber and steel joists, trusses or Structural Wood Members* with bridging as required and with ends firestopped.
 - C. **Gypsum Board*** – Nom 5/8 in. thick as specified in the individual Floor-Ceiling Design. Max diam of opening is 5-1/8 in.
2. **Cables** – Max 3/C No. 3/0 AWG with 1 No. 8 AWG bare copper ground, aluminum-clad or steel-clad TEK cable, with or without polyvinyl chloride jacket to be installed concentrically or eccentrically within the firestop. The annular space between cable and periphery of opening shall be min 0 in. (point contact) to max 3/4 in. Cable to be rigidly supported on both sides of assembly.
3. **Fill, Void or Cavity Material* – Sealant** – Min 3/4 in. thickness of fill material applied within the annulus, flush with top surface of floor. Min 5/8 in. thickness of fill material applied within the annulus, flush with bottom surface of ceiling. Min 1/4 in. diam bead of fill material shall be applied at the cable/floor and cable/ceiling interfaces at point contact locations on both sides of assembly.

GRABBER CONSTRUCTION PRODUCTS INC – GrabberGard EFC

*Bearing the UL Classified Marking





System No. W-J-1157

F Ratings – 1, 2, 3 and 4 Hr (Item 1)

T Ratings – 0 & 1/4 Hr (See Item 2)

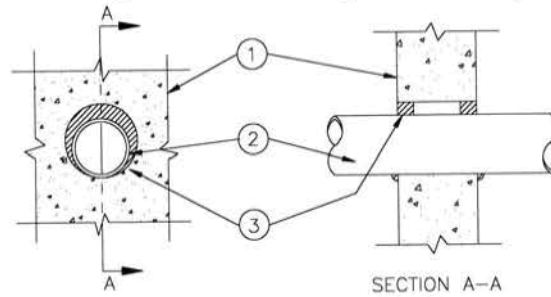

1. **Wall Assembly** – Min 4-7/8, 6-1/8, 7-3/8, 8-5/8 in. thick normal weight or lightweight (100-150 pcf) concrete for 1, 2, 3, 4 hr rated assemblies, respectively. Wall may also be constructed of any UL Classified **Concrete Blocks***. Max diam of opening is 14-1/8 in. See **Concrete Blocks (CAZT)** category in the Fire Resistance Directory for names of manufacturers.
The hourly F Rating of the firestop system is equal to the hourly fire rating of the wall assembly in which it is installed.
2. **Through Penetrants** – One metallic pipe, conduit or tubing installed either concentrically or eccentrically within the firestop system. The annular space between pipe, conduit or tubing and periphery of opening shall be min 0 in. to max 1-3/8 in. Pipe, conduit or tubing to be rigidly supported on both sides of wall assembly. The following types and sizes of metallic pipes, conduits or tubing may be used:
 - A. **Steel Pipe** – The following types and sizes of steel pipes may be used:
 - A1. Nom 4 in. diam (or smaller) Schedule 7 (or heavier) steel pipe.
 - A2. Nom 8 in. diam (or smaller) Schedule 10 (or heavier) steel pipe.
 - A3. Nom 10 in. diam (or smaller) Schedule 20 (or heavier) steel pipe.
 When steel pipe is used, T Rating is 1/4 hr for nom 4 in. diam (or smaller) and 0 hr for steel pipes greater than nom 4 in. diam.
 - B. **Iron Pipe** – Nom 4 in. diam (or smaller) cast or ductile iron pipe. When iron pipe is used T Rating is 1/4 hr.
 - C. **Conduit** – Nom 4 in. diam (or smaller) steel electrical metallic tubing (EMT). When EMT is used T Rating is 1/4 hr.
 - D. **Copper Tubing** – Nom 4 in. diam (or smaller) Type L (or heavier) copper tubing. When copper tube is used T Rating is 0 hr.
 - E. **Copper Pipe** – Nom 4 in. diam (or smaller) Regular (or heavier) copper pipe. When copper pipe is used T Rating is 0 hr.
3. **Fill, Void or Cavity Material* – Sealant** – Min 5/8 in. thickness of sealant for 1 rated wall assembly, and min 1 in. thickness of sealant for 2, 3 and 4 hr rated wall assemblies, applied within the annulus, flush with both surfaces of wall. At point contact location between penetrant and periphery of opening, a min 1/2 in. diam bead of fill material shall be installed at the concrete/penetrant interface on both surfaces of wall.

GRABBER CONSTRUCTION PRODUCTS INC – GrabberGard EFC

*Bearing the UL Classification Marking





System No. W-J-2153

F Rating – 1, 2, 3 & 4 Hr (See Item 1)

T Rating – 1, 2, 3 & 4 Hr

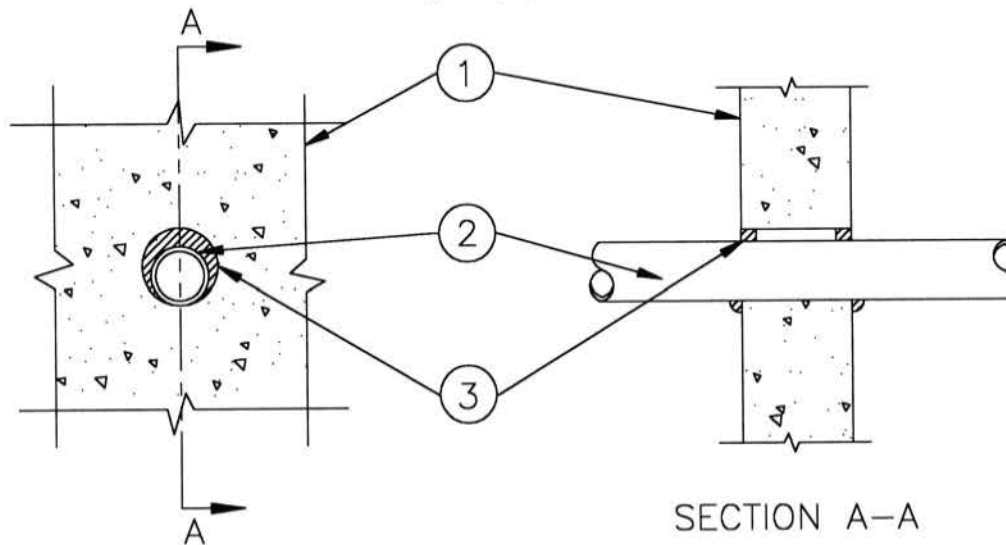

1. **Wall Assembly** – Min 4-7/8, 6-1/8, 7-3/8 or 8-5/8 in. thick lightweight or normal weight (100- 150 pcf) concrete for 1, 2, 3 or 4 hour rated wall assemblies, respectively. Wall may also be constructed of any UL Classified **Concrete Blocks**. Max diam of opening is 3-1/8 in. See **Concrete Blocks (CAZT)** category in the Fire Resistance Directory for names of manufacturers. The F and T Ratings of the firestop system is equal to the hourly fire rating of the wall assembly in which it is installed
2. **Through Penetrants** – One nonmetallic pipe or tubing installed either concentrically or eccentrically within the firestop system. The annular space between pipe and periphery of opening shall be min 0 in. to max 7/8 in. Pipe or tubing to be rigidly supported on both sides of wall assembly. The following types and sizes of nonmetallic pipes or tubing may be used:
 - A. **Chlorinated Polyvinyl Chloride (CPVC) Pipe** – Nom 2 in. diam (or smaller) SDR 11 CPVC pipe for use in closed (process or supply) piping systems.
 - B. **Polyvinyl Chloride (PVC) Pipe** – Nom 2 in. diam (or smaller) Schedule 40 (or heavier) cellular or solid core PVC pipe for use in closed (process or supply) piping systems.
 - C. **Crosslinked Polyethylene (PEX) Tubing** – Nom 3/4 in. diam (or smaller) SDR 9 PEX tubing for use in closed (process or supply) piping systems.
3. **Fill, Void or Cavity Material*** – **Sealant** – Min 5/8 in. thickness for 1 hr rated wall assemblies and 1 in. thickness of fill material for 2, 3 or 4 hr rated wall assemblies, respectively, applied within the annulus, flush with both surfaces of wall. At point contact location between penetrant and periphery of opening, a min 1/2 in. diam bead of fill material shall be applied at the concrete/penetrant interface on both surfaces of wall.

GRABBER CONSTRUCTION PRODUCTS INC – GrabberGard EFC

*Bearing the UL Classification Marking





System No. W-J-3123

F Rating – 1 & 2 Hr (See Item 1)

T Rating – 3/4 Hr

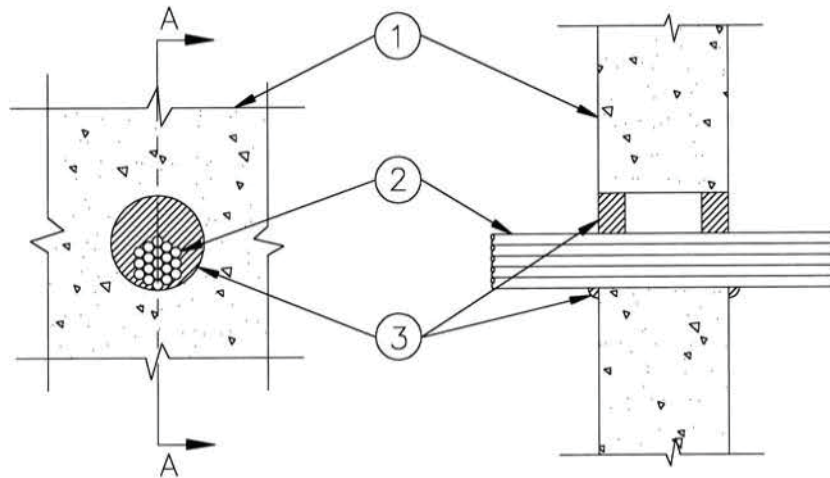

SECTION A-A

1. **Wall Assembly** – Min 4-7/8 or 6-1/8 in. thick lightweight or normal weight (100-150 pcf) concrete for 1 or 2 hr rated assemblies, respectively. Wall may also be constructed of any UL Classified **Concrete Blocks***. Max diam of opening is 3-1/8 in.
See **Concrete Blocks (CAZT)** category in the Fire Resistance Directory for names of manufacturers.
2. **Cables** – Aggregate cross-sectional area of cable in opening to be max 44 percent of the cross-sectional area of the opening. The annular space between cables and periphery shall be min 0 in. (point contact) to max 1-1/2 in. Cables to be rigidly supported on both sides of floor or wall assembly. Any combination of the following types and sizes of copper conductor cables may be used:
 - A. 3/C No. 3/0 (or smaller) copper conductor polyvinyl chloride (PVC) jacketed aluminum clad or steel clad TEK cable with XLPE insulation.
 - B. 2/C No. 10 AWG (or smaller) copper conductor PVC cable with XLPE insulation.
3. **Fill, Void or Cavity Material* – Sealant** – Min 5/8 or 1-1/4 in. thickness of fill material for 1 or 2 hr rated wall assemblies, respectively, applied within the annulus, flush with both surfaces of wall. Sealant to be forced into interstices of cable group to max extent possible. At the point contact location between cable(s) and concrete, a min 1/2 in. diam bead of fill material shall be applied at the concrete/cable interface on both surfaces of wall.

GRABBER CONSTRUCTION PRODUCTS INC – GrabberGard EFC

*Bearing the UL Classification Marking





System No. W-J-4047

F-Rating – 2 Hr
T-Rating – 3/4 Hr

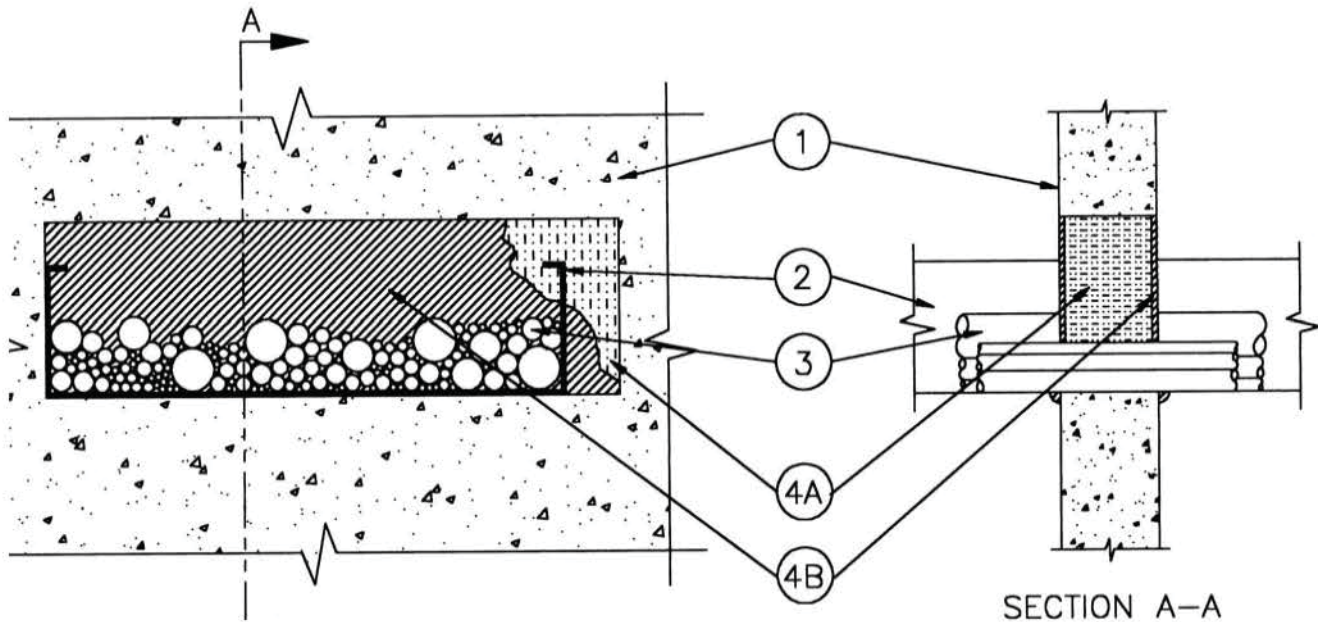

1. **Wall Assembly** – Min 4-7/8 in. thick lightweight or normal weight (100-150 pcf) concrete. Wall may also be constructed of any UL Classified **Concrete Blocks***. Max opening size to be 26 in. by 8 in. (208 sq. in.).
See **Concrete Blocks (CAZT)** category in the Fire Resistance Directory for names of manufacturers.
2. **Cable Tray +** – Max 24 in. wide by max 6 in. deep 15 gauge (or heavier) aluminum or steel cable tray installed within the opening. The annular space between the cable tray and the periphery of the opening shall be min 0 in. (point contact) to max 2 in. Cable tray to be rigidly supported on both sides of wall assembly.
3. **Cables** – Aggregate cross-sectional area of cables in opening to be max 40 percent of the cross-sectional area of the opening. The annular space between cables and periphery of opening shall be min 0 in. (point contact) to max 5-3/4 in. Cables to be rigidly supported on both sides of wall assembly. The following types and sizes of cables may be used:
 - A. 1/C 750 kcmil (or smaller) copper conductor polyvinyl chloride (PVC) jacketed aluminum clad or steel clad TEK cable with cross-linked polyethylene (XLPE) insulation.
 - B. 3/C 350 kcmil (or smaller) copper conductor PVC jacketed aluminum clad or steel clad TEK cable with XLPE insulation.
 - C. 4/C No. 14 AWG (or smaller) copper conductor PVC jacketed aluminum clad or steel clad TEK cable with XLPE insulation.
 - D. Max 25 pair No. 20 AWG (and smaller) copper conductor PVC jacketed cable with PVC insulation.
 - E. 1/C 400 kcmil (or smaller) aluminum or copper conductor cable with XLPE insulation.
 - F. 4/C No. 6 AWG (or smaller) copper conductor PVC jacketed cable with XLPE insulation.





4. Firestop System – The firestop system shall consist of the following:

- A. **Packing Material** – Min 3-5/8 in. thickness of min 4 pcf mineral wool batt insulation packed into opening as a permanent form. Packing material to be recessed from both surfaces of wall as to accommodate the required thickness of fill material (Item B).
- B. **Fill, Void or Cavity Material* – Sealant** – Min 1/4 in. thickness of fill material applied within annulus, flush with both sides of wall. At point contact location between penetrant and periphery of opening, a min 1/2 in. diam bead of fill material shall be applied at the concrete/penetrant interface on both surfaces of wall.

GRABBER CONSTRUCTION PRODUCTS INC – GrabberGard EFC

+ Bearing the UL Listing Marking

*Bearing the UL Classification Marking





System No. W-J-7066

F Rating – 1 & 2 Hr (See Item 1)

T Rating – 0 Hr

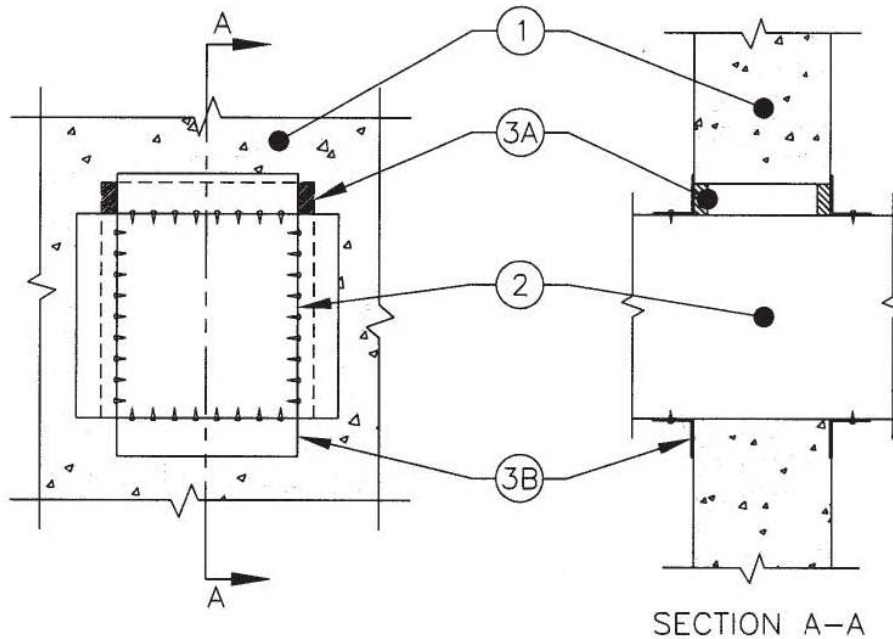

1. **Wall Assembly** – Min 6 in. thick reinforced lightweight or normal weight (100-150 pcf) concrete. Wall may also be constructed of any UL Classified **Concrete Blocks***. Max size of opening to be 957 sq. in. with a max dimension of 33 in.
See **Concrete Blocks (CAZT)** category in the Fire Resistance Directory for names of manufacturers.
2. **Steel Duct** – Nom 26 in. by 30 (or smaller) No. 24 gauge (or heavier) galv steel duct to be installed either concentrically or eccentrically within the firestop system. An annular space of min 0 in. (point contact) to max 1-1/2 in. is required within the firestop system. Steel duct to be rigidly supported on both sides of wall assembly.
3. **Firestop System** – The firestop system shall consist of the following:
 - A. **Fill, Void or Cavity Material* – Sealant** – Min 5/8 in. thickness of fill material applied within annulus, flush with both surfaces of wall assembly. At point contact location between duct and concrete, a min 1/4 in. diam bead of sealant shall be applied at the concrete/duct interface on both surfaces of wall assembly.
 - B. **Retaining Angles** – Min 16 gauge galv steel angles sized to lap duct a min of 2 in. and lap wall surfaces of a min of 1 in. Angles attached to duct on both sides of wall with min 1/2 in. long, No. 10 (or larger) sheet metal screws spaced a max of 1 in. from each end of duct and spaced a max of 6 in. OC.

GRABBER CONSTRUCTION PRODUCTS INC – GrabberGard EFC

*Bearing the UL Classification Marking





System No. W-J-7067

F Rating – 1 & 2 Hr (See Item 1)

T Rating – 0 Hr

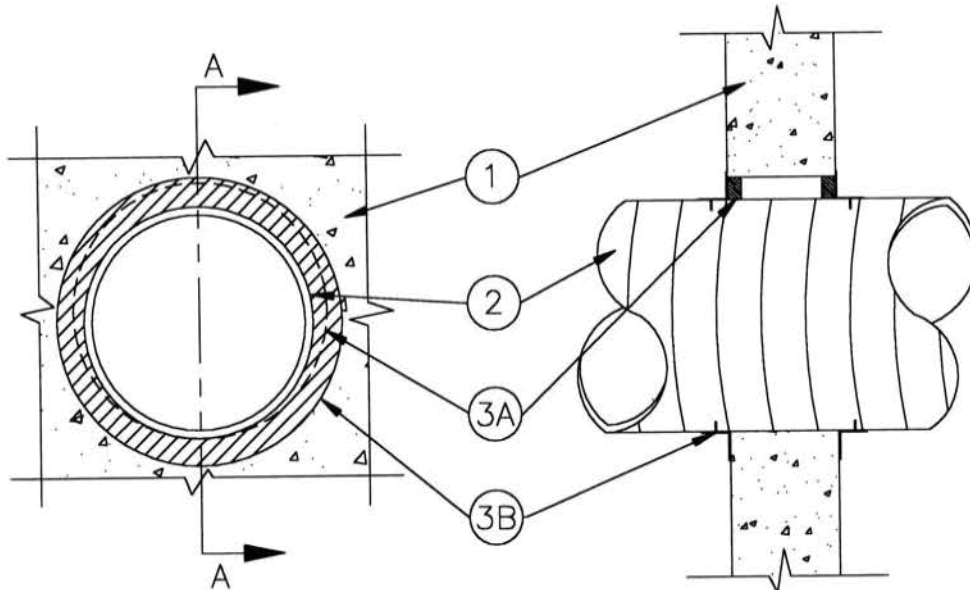

1. **Wall Assembly** – Min 6 in. thick reinforced lightweight or normal weight (100-150 pcf) concrete. Wall may also be constructed of any UL Classified **Concrete Blocks***. Max diam of opening is 17 in.
See **Concrete Blocks (CAZT)** category in the Fire Resistance Directory for names of manufacturers.
2. **Steel Duct** – Nom 16 in. diam (or smaller) No. 22 gauge (or heavier) galv steel duct to be installed either concentrically or eccentrically within the firestop system. The annular space between duct and periphery of opening shall be min 0 in. (point contact) to max 1 in. Duct to be rigidly supported on both sides of wall assembly.
3. **Firestop System** – The firestop system shall consist of the following:
 - A. **Fill, Void or Cavity Material* – Sealant** – Min 5/8 in. thickness of fill material applied within annulus, flush with both surfaces of wall assembly. At the point contact location between duct and concrete, a min 1/4 in. diam bead of sealant shall be applied at the concrete/duct interface on both surfaces of wall assembly.

GRABBER CONSTRUCTION PRODUCTS INC – GrabberGard EFC

- B. **Retaining Angles** – Min 16 gauge galv steel angles roll-formed and sized to lap duct a min of 1 in. and lap wall surfaces of a min of 1 in. Angles attached to duct on both sides of wall with min 1/2 in. long, No. 10 (or larger) sheet metal screws spaced a max of 6 in. OC.

*Bearing the UL Classification Marking





System No. W-L-1342

F Rating – 1, 2, 3 & 4 Hr (See Item 1)

T Rating – 0 & 1/4 Hr (See Item 2)

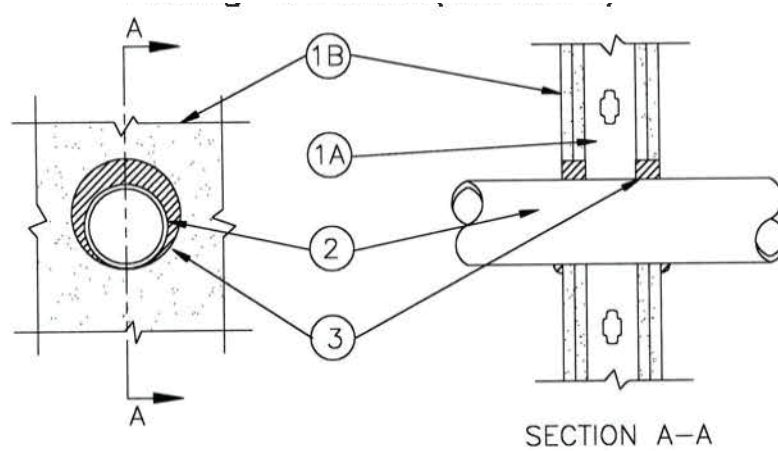

1. **Wall Assembly** – The 1, 2, 3 or 4 hr fire-rated gypsum wallboard/stud wall assembly shall be constructed of the materials and in the manner specified in the individual U300 or U400 Series Wall and Partition Designs in the UL Fire Resistance Directory and shall include the following construction features:
 - A. **Studs** – Wall framing may consist of either wood studs or steel channel studs. Wood studs to consist of nom 2 by 4 in. lumber spaced 16 in. OC. Steel studs to be min 3-5/8 in. wide and spaced max 24 in. OC.
 - B. **Gypsum Board*** – Thickness, type, number of layers and fasteners as specified in the individual Wall and Partition Design. Max diam of opening is 25-3/8 in. The hourly F Rating of the firestop system is equal to the hourly fire rating of the wall assembly in which it is installed.
2. **Through Penetrants** – One metallic pipe, conduit or tubing installed either concentrically or eccentrically within the firestop system. The annular space between pipe, conduit or tubing and periphery of opening shall be min 0 (point contact) in. to max 1-1/4 in. Pipe, conduit or tubing to be rigidly supported on both sides of wall assembly. The following types and sizes of metallic pipes, conduits or tubing may be used:
 - A. **Steel Pipe** – The following types and sizes of steel pipes may be used:
 - A1. Nom 12 in. diam (or smaller) Schedule 10 (or heavier) steel pipe.
 - A2. Nom 24 in. diam (or smaller) Schedule 40 (or heavier) steel pipe.
 When steel pipe is used, T Rating is 1/4 hr for nom 4 in, diam (or smaller) and 0 hr for steel pipes greater than nom 4 in, diam.
 - B. **Iron Pipe** – Nom 24 in. diam (or smaller) cast or ductile iron pipe. **When iron pipe is used T Rating is 1/4 hr.**
 - C. **Conduit** – Nom 4 in. diam (or smaller) steel electrical metallic tubing (EMT) or steel conduit. **When EMT or steel conduit is used, T Rating is 1/4 hr.**
 - D. **Copper Tubing** – Nom 6 in. diam (or smaller) Type L (or heavier) copper tubing. **When copper tube is used, T Rating is 0 hr.**
 - E. **Copper Pipe** – Nom 6 in. diam (or smaller) Regular (or heavier) copper pipe. **When copper pipe is used, T Rating is 0 hr.**





W-L-1342

3. **Fill, Void or Cavity Material* – Sealant** – Min 5/8 in. thickness of fill material for 1 hr rated wall assemblies and 1 in. thickness of fill material for 2, 3 or 4 hr rated wall assemblies, applied within the annulus, flush with both surfaces of wall. At point contact location between penetrant and gypsum board, a min 1/2 in. diam bead of fill material shall be installed at the gypsum board/penetrant interface on both surfaces of wall.

GRABBER CONSTRUCTION PRODUCTS INC – GrabberGard EFC

*Bearing the UL Classification Marking





System No. W-L-1475

ANSI/UL 1479 (ASTM E814)

F Rating – 2 Hr
FT Rating – 0 Hr

CAN/ULC S 115

F Rating – 2 Hr
FT Rating – 0 Hr
FH – Rating 2 Hr
FTH Rating – 0 Hr

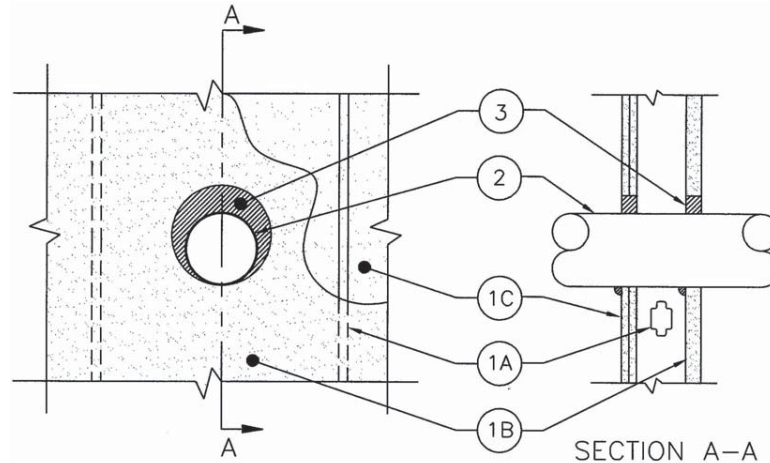

1. **Wall Assembly** – The 2 hr fire rated shaft wall assembly shall be constructed of the materials and in the manner described in the individual U400, V400 or W 400 -Series Wall or Partition Design in the UL Fire Resistance Directory and shall include the following construction features:

- A. Steel Studs – C-H-shaped studs, 2-1/2 in.(64 mm) wide by min 1-1/2 in. (38 mm) deep, spaced 24 in. (610 mm) OC.
- B. Gypsum Board* – 1 in. (25 mm) thick gypsum board liner panels, supplied in nom 24 in. (610 mm) widths as specified in the individual Wall and Partition Design. Max diam of opening is 10 in. (254 mm).
- C. Gypsum Board* – Two layers of 1/2 in. (13 mm) thick gypsum board as specified in the individual Wall and Partition Design. Max diam of opening is 10 in. (254 mm).

2. **Through Penetrants** – One metallic pipe, conduit or tubing installed either concentrically or eccentrically within the firestop system. The annular space between pipe, conduit or tubing and periphery of opening shall be min 0 in. (point contact) to max 1-3/8 in. (35 mm). Pipe, conduit or tubing to be rigidly supported on both sides of wall assembly. The following types of and sizes of metallic pipes, conduits or tubing may be used:

- A. Steel Pipe – Nom 8 in. (203 mm) diam (or smaller) Schedule 10 (or heavier) steel pipe
- B. Iron Pipe – Nom 8 in. (203 mm) diam (or smaller) cast or ductile iron pipe
- C. Conduit – Nom 4 in. (102 mm) diam (or smaller) steel electrical metallic tubing (EMT) or nom 6 in. (152mm) (or smaller) rigid steel conduit
- D. Copper Tubing – Nom 4 in.(102 mm) diam (or smaller) Type L (or heavier) copper tubing
- E. Copper Pipe – Nom 4 in. (102 mm) diam (or smaller) Regular (or heavier) copper pipe

3. **Fill, Void or Cavity Material*** – Sealant – Min 1 in. (25 mm) thickness of sealant applied within the annulus, flush with both surfaces of wall. Min. 1/2 in. (13 mm) diam bead of fill material shall be applied at the gypsum board/penetrant interface at the point contact location on outer surface of wall on side using two layers of 1/2 in. (13 mm) gypsum board (Item 1C).

GRABBER CONSTRUCTION PRODUCTS INC – GrabberGard EFC

*Bearing the UL Classification Marking





System No. W-L-2387

F Rating – 1, 2, 3 & 4 Hr (See Item 1)
T Rating – 1, 2, 3 & 4 Hr (See Item 1)

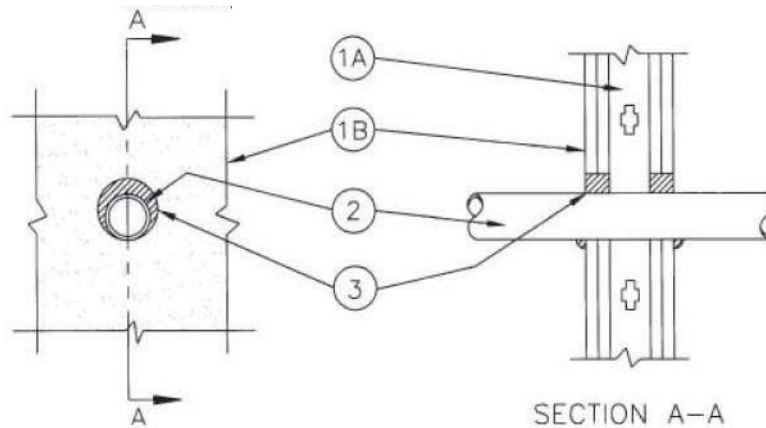

1. **Wall Assembly** – The 1, 2, 3 or 4 hr fire-rated gypsum wallboard/stud wall assembly shall be constructed of the materials and in the manner specified in the individual U300 or U400 Series Wall and Partition Designs in the UL Fire Resistance Directory and shall include the following construction features:
 - A. **Studs** – Wall framing may consist of either wood studs or steel channel studs. Wood studs to consist of nom 2 by 4 in. lumber spaced 16 in. OC. Steel studs to be min 3-5/8 in. wide and spaced max 24 in. OC.
 - B. **Gypsum Board*** – The gypsum board type, thickness, number of layers, fasteners type and sheet orientation shall be as specified in the individual U300 or U400 Series Design in the UL Fire Resistance Directory. Max diam of opening is 3-1/8 in.
The hourly F and T Ratings of the firestop system are equal to the hourly fire rating of the assembly in which it is installed.
2. **Through Penetrants** – One nonmetallic pipe or tubing installed either concentrically or eccentrically within the firestop system. Pipe or tubing to be rigidly supported on both sides of wall assembly. The following types and sizes of nonmetallic pipes or tubing may be used:
 - A. **Chlorinated Polyvinyl Chloride (CPVC) Pipe** – Nom 2 in. diam (or smaller) SDR 11 CPVC pipe for use in closed (process or supply) piping systems. The annular space between pipe and periphery of opening shall be min 1/4 in. to max 1/2 in.
 - B. **Crosslinked Polyethylene (PEX) Tubing** - Nom 1-1/2 in. diam (or smaller) SDR 9 PEX tubing for use in closed (process or supply) piping systems. The annular space between tubing and periphery of opening shall be min 1/4 in. to max 3/8 in.
 - C. **Polyvinyl Chloride (PVC) Pipe** - Nom 2 in. diam (or smaller) Schedule 40 solid core or cellular core PVC pipe for use in closed (process or supply) piping system. The annular space between pipe and periphery of opening shall be min 1/4 in. to max 1/2 in.
3. **Fill, Void or Cavity Material* – Sealant** – Min 5/8 in. thickness of fill material for 1 hr rated wall assemblies and min 1 in. thickness of fill material for 2, 3 or 4 hr rated wall assemblies, applied within the annulus, flush with both surfaces of wall.

GRABBER CONSTRUCTION PRODUCTS INC – GrabberGard EFC

*Bearing the UL Classification Marking





System No. W-L-3247

F Rating – 1 & 2 Hr (See Item 1)

T Rating – 3/4 Hr (See Item 1)

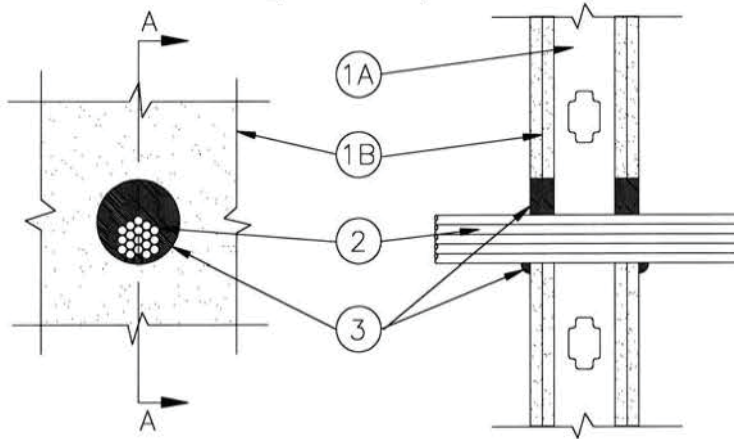

1. **Wall Assembly** – The 1 or 2 hr fire-rated gypsum wallboard/stud wall assembly shall be constructed of the materials and in the manner specified in the individual U300 or U400 Series Wall and Partition Designs in the UL Fire Resistance Directory and shall include the following construction features:
 - A. **Studs** – Wall framing may consist of either wood studs or steel channel studs. Wood studs to consist of nom 2 by 4 in. lumber spaced 16 in. OC. Steel studs to be min 3-5/8 in. wide and spaced max 24 in. OC.
 - B. **Gypsum Board*** – Thickness, type, number of layers and fasteners as specified in the individual Wall and Partition Design. Max diam of opening is 3-1/8 in.

The hourly F Rating of the firestop system is equal to the hourly fire rating of the wall assembly in which it is installed. The T rating is 1/2 hr for 1 hr rated and 3/4 hr for 2 hr rated assemblies.
2. **Cables** – Aggregate cross-sectional area of cable in opening to be max 44 percent of the cross-sectional area of the opening. The annular space between cables and periphery shall be min 0 in. (point contact) to max 1-1/2 in. Cables to be rigidly supported on both sides of wall assembly. Any combination of the following types and sizes of copper conductor cables may be used:
 - A. 3/C No. 3/0 (or smaller) copper conductor polyvinyl chloride (PVC) jacketed aluminum clad or steel clad TEK cable with XLPE insulation
 - B. 2/C No. 10 AWG (or smaller) copper conductor PVC jacketed cable with XLPE insulation.
 - C. **Through Penetration Product*** – Max 3/C No. 2 AWG (or smaller) aluminum or steel clad Armored Cable* or aluminum or steel clad Metal Clad Cable* with copper conductors.
3. **Fill, Void or Cavity Material* – Sealant** – Min 5/8 or 1-1/4 in. thickness of fill material for 1 or 2 hr rated wall assemblies, respectively, applied within the annulus, flush with both surfaces of wall. Caulk to be forced into interstices of cable group to max extent possible. At the point contact location between cable(s) and gypsum board, a min 1/2 in. diam bead of fill material shall be applied at the gypsum board/cable interface on both surfaces of wall.

GRABBER CONSTRUCTION PRODUCTS INC – GrabberGard EFC

*Bearing the UL Classification Marking





System No. W-L-4047

F Rating – 1 & 2 Hr (See Item 1B)

T Rating – 3/4 Hr

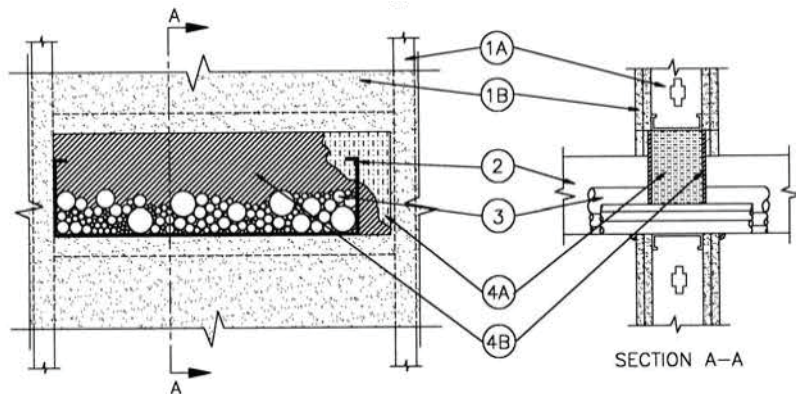

1. **Wall Assembly** – The 1 or 2 hr fire-rated gypsum wallboard/stud wall assembly shall be constructed of the materials and in the manner specified in the individual U300 or U400 Series Wall and Partition Designs in the UL Fire Resistance Directory and shall include the following construction features:
 - A. **Studs** – Wall framing may consist of either wood studs or steel channel studs. Wood studs to consist of nom 2 by 4 in. lumber spaced 16 in. OC. Steel studs to be min 3-5/8 in. wide and spaced max 24 in. OC. Additional framing members may be installed in stud cavity containing cable tray (Item 2) to form a rectangular box around cable tray.
 - B. **Wallboard, Gypsum*** – Thickness, type, number of layers and fasteners, as specified in the individual Wall and Partition Design. Max opening size to be 26 in. by 8 in. (208 sq. in.).
The hourly F Rating of the firestop system is equal to the hourly F Rating of the wall assembly in which it is installed.
2. **Cable Tray** + – Max 24 in. wide by max 6 in. deep 15 ga. (or heavier) aluminum or steel cable tray installed within the opening. The annular space between the cable tray and periphery of the opening shall be min 0 in. (point contact) to max 2 in. Cable tray to be rigidly supported on both sides of wall assembly.
3. **Cables** – Aggregate cross-sectional area of cables in cable tray to be max 40 percent of the cross-sectional area of the opening. The annular space between cables and periphery of opening shall be min 0 in. (point contact) to max 5-3/4 in. Cables to be rigidly supported on both sides of wall assembly. Any combination of the following types and sizes of cables may be used:
 - A. 1/C 750 kcmil (or smaller) copper conductor polyvinyl chloride (PVC) jacketed aluminum clad or steel clad TEK cable with cross-linked polyethylene (XLPE) insulation.
 - B. 3/C 350 kcmil (or smaller) copper conductor PVC jacketed aluminum clad or steel clad TEK cable with XLPE insulation.
 - C. 4/C No. 14 AWG (or smaller) copper conductor PVC jacketed aluminum clad or steel clad TEK cable with XLPE insulation.
 - D. Max 25 pair No. 20 AWG (or smaller) copper conductor PVC jacketed cable with PVC insulation.
 - E. 1/C 400 kcmil (or smaller) aluminum or copper conductor cable with XLPE insulation.
 - F. 4/C No. 6 AWG (or smaller) copper conductor PVC jacketed cable with XLPE insulation.





4. Firestop System — The firestop system shall consist of the following:

- A. **Packing Material** — Min 3-5/8 in. thickness of min 4 pcf mineral wool batt insulation firmly packed into opening as a permanent form. Packing material to be installed flush with both sides of studs (Item 1A). Packing material to be recessed from both surfaces of wall as required to accommodate the required thickness of fill material (Items 4B).
- B. **Fill, Void or Cavity Material*** — Sealant — Min 1/4 in. thickness of fill material applied within annulus, flush with both surfaces of wall. At point contact location between penetrant and periphery of opening, a min 1/2 in. diam bead of fill material shall be applied at the gypsum board/penetrant interface on both surfaces of wall assembly.

GRABBER CONSTRUCTION PRODUCTS INC — GrabberGard EFC

*Bearing the UL Classification Marking

+ Bearing the UL Listing Marking





System No. W-L-5219

F Rating – 1 & 2 Hr (See Item 1)
T Rating – 1/2, 1 & 2 Hr (See Item 3)

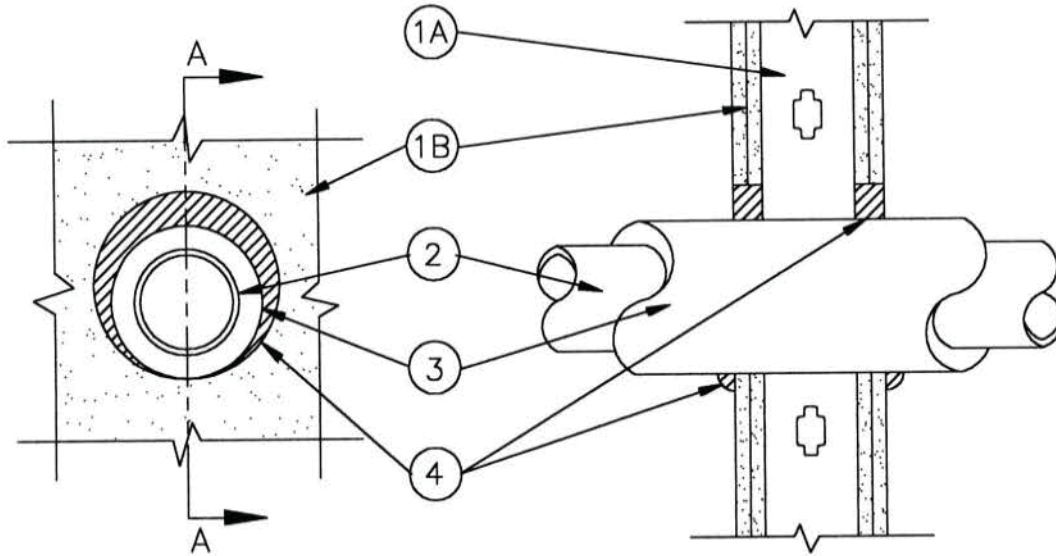

1. **Wall Assembly** – The 1 or 2 hr fire-rated gypsum wallboard/stud wall assembly shall be constructed of the materials and in the manner specified in the individual U300 or U400 Series Wall and Partition Designs in the UL Fire Resistance Directory and shall include the following construction features:
 - A. **Studs** – Wall framing may consist of either wood studs or steel channel studs. Wood studs to consist of nom 2 by 4 in. lumber spaced 16 in. OC. Steel studs to be min 3-5/8 in. wide and spaced max 24 in. OC.
 - B. **Gypsum Board*** – Nom 5/8 in. by 4 ft. wide with square or tapered edges. The gypsum wallboard type, number of layers, and fastener type and sheet orientation shall be as specified in the individual Wall and Partition Design. Max diam of opening is 7-1/2 in.
The hourly F Rating of the firestop system is equal to the hourly fire rating of the wall assembly in which it is installed.
2. **Through Penetrants** – One metallic pipe or tubing to be centered within the firestop system. Pipe or tubing to be rigidly supported on both sides of wall assembly. The following types and sizes of metallic pipes and tubing may be used:
 - A. **Steel Pipe** – Nom 4 in. diam (or smaller) Schedule 40 (or heavier) steel pipe
 - B. **Iron Pipe** – Nom 4 in. diam (or smaller) cast or ductile iron pipe
 - C. **Copper Tubing** – Nom 2 in. diam (or smaller) Type L (or heavier) copper tube
 - D. **Copper Pipe** – Nom 2 in. diam (or smaller) Regular (or heavier) copper pipe





3. **Tube Insulation – Plastic+** – Nom 1/2 or 3/4 in. thick acrylonitrile butadiene/polyvinyl chloride (AB/PVC) flexible foam furnished in the form of tubing. The annular space between tube insulation and the periphery of opening shall be min 0 in. (point contact) to max 1 in. See **Plastics+** (QMFZ2) category in the Recognized Component Directory for names of manufacturers. Any Recognized Component tube insulation material meeting the above specifications and having a UL 94 Flammability Classification of 94-5VA may be used.

The T Rating is dependant on the hourly F Rating, type of penetrant and thickness of insulation, as shown below.

F Rating	Penetrant	Insulation Thickness Inches	T Rating
1 Hr	A and B	1/2	1/2 Hr
1 Hr	A and B	3/4	1 Hr
1 Hr	C and D	1/2 and 3/4	1/2 Hr
2 Hr	A and B	1/2	1/2 Hr
2 Hr	A and B	3/4	1 Hr
2 Hr	C and D	1/2 and 3/4	1/2 Hr

4. **Fill, Void or Cavity Material* – Sealant** – Min 5/8 in. or 1-1/4 in. thickness of fill material applied within the annulus, flush with both surfaces of wall, for 1 and 2 hr. rated assemblies, respectively. At the point contact location between insulation/wallboard interface, a min. 1/2 in. diam bead of fill material shall be applied on both sides of wall.

GRABBER CONSTRUCTION PRODUCTS INC – GrabberGard EFC

*Bearing the UL Classification Mark





System No. W-L-7109

F Rating – 1 & 2 Hr (See Item 1)

T Rating – 0 Hr

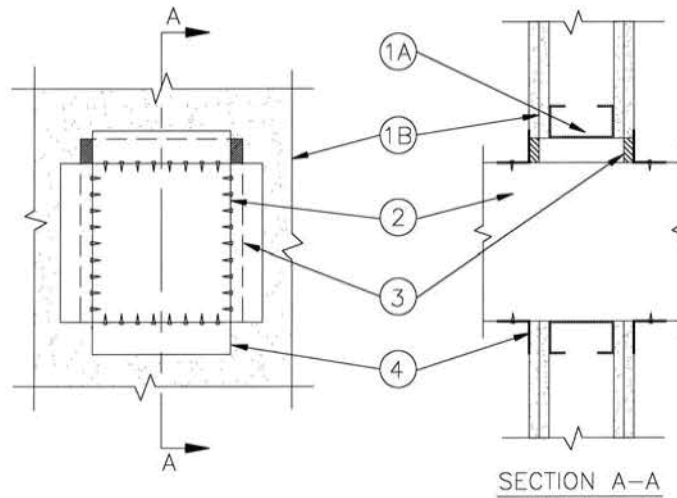

1. **Wall Assembly** – The 1 and 2 hr fire rated gypsum board/stud wall assembly shall be constructed of the materials and in the manner specified in the individual U400 Series Wall and Partition Designs in the UL Fire Resistance Directory and shall include the following construction features:
 - A. **Studs** – Wall framing shall consist of steel channel studs to be min 3-5/8 in. wide and spaced max 24 in. OC. Additional 3-5/8 in. wide steel studs shall be used to completely frame opening.
 - B. **Gypsum Board*** – Thickness, type, number of layers and fasteners as required in the individual Wall and Partition Design. Max size of opening to be 957 sq in. with a max dimension of 33 in.

The hourly F Rating of the firestop system is equal to the hourly fire rating of the wall assembly in which it is installed.
2. **Through-Penetrant** – Nom 26 in. by 30 (or smaller) No. 24 gauge (or heavier) galv steel duct to be installed either concentrically or eccentrically within the firestop system. An annular space of min 0 in. (point contact) to max 1-1/2 in. is required within the firestop system. Steel duct to be rigidly supported on both sides of wall assembly.
3. **Fill, Void or Cavity Material* – Sealant** – Min 5/8 in. thickness of fill material applied within annulus, flush with both surfaces of wall assembly. At the point contact location between duct and gypsum board, a min 1/4 in. diam bead of sealant shall be applied at the gypsum board/duct interface on both surfaces of wall assembly.

GRABBER CONSTRUCTION PRODUCTS INC – GrabberGard EFC

4. **Retaining Angles** – Min 16 gauge galv steel angles sized to lap duct a min of 2 in. and lap wall surfaces of a min of 1 in. Angles attached to duct on both sides of wall with min 1/2 in. long, No. 10 (or larger) sheet metal screws spaced a max of 1 in. from each end of duct and spaced a max of 6 in. OC.

*Bearing the UL Classification Marking





System No. W-L-7110

F Rating – 1 & 2 Hr (See Item 1)

T Rating – 0 Hr

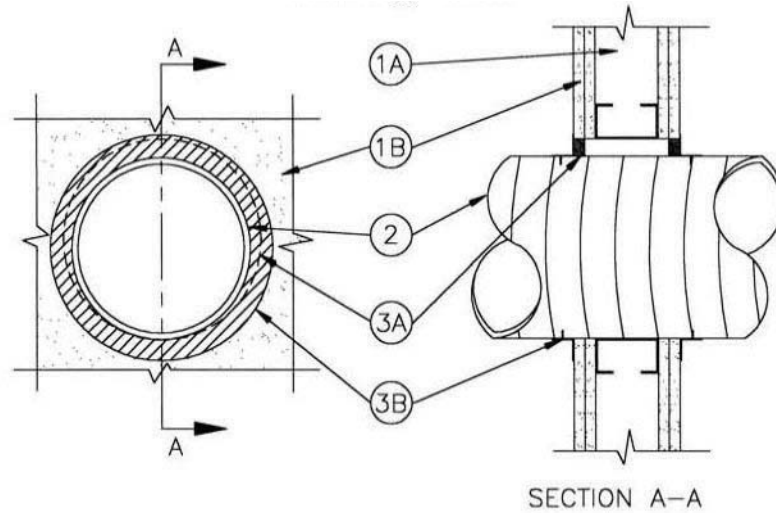

1. **Wall Assembly** – The 1 or 2 hr fire rated gypsum board/stud wall assembly shall be constructed of the materials and in the manner specified in the individual U400 Series Wall and Partition Designs in the UL Fire Resistance Directory and shall include the following construction features:
 - A. **Studs** – Wall framing may consist of either wood or steel channel studs. Wood studs to consist of nom 2 by 4 in. lumber spaced 16 in. OC. Steel studs to be min 2-1/2 in. wide and spaced max 24 in. OC. Additional studs shall be used to completely frame opening.
 - B. **Gypsum Board*** – Thickness, type, number of layers and fasteners as required in the individual Wall and Partition Design. Max diam of opening is 17 in.

The hourly F Rating of the firestop system is equal to the hourly fire rating of the wall assembly in which it is installed.
2. **Steel Duct** – Nom 16 in. (or smaller) No. 22 gauge (or heavier) steel duct to be installed either concentrically or eccentrically within the firestop system. The annular space between duct and periphery of opening shall be min 0 in. (point contact) to max 1 in. Duct to be rigidly supported on both sides of wall assembly.
3. **Firestop System** – The firestop system shall consist of the following:
 - A. **Fill, Void or Cavity Material* – Sealant** – Min 5/8 in. or 1-1/4 in. thickness of fill material applied within annulus, flush with both surfaces of wall for 1 and 2 hr walls, respectively. At the point contact location between duct and gypsum board, a min 1/4 in. diam bead of sealant shall be applied at the gypsum board/duct interface on both surfaces of wall assembly.

GRABBER CONSTRUCTION PRODUCTS INC – GrabberGard EFC

- B. **Retaining Angles** – Min 16 gauge galv steel angles roll-formed and sized to lap duct a min of 1 in. and lap wall surfaces a min of 1 in. Angles attached to duct on both sides of wall with min 1/2 in. long, No. 10 (or larger) sheet metal screws spaced a max of 6 in. OC.

*Bearing the UL Classification Marking



MATERIAL SAFETY DATA SHEET

MSDS Name: GrabberGard EFC

Revision Date: August 30, 2012

1. Product and Company Identification

Product Name: GrabberGard EFC
 Product Code: GGEFC10, GGEFC 20, GGEFC29, GGEFC5
 Supplier: Grabber Construction Products
 205 Mason Circle
 Concord, CA 94520
 Medical Emergency: Passive Fire Protection Partners, 1412 Derwent Way, Delta, BC V3M 6H9, (800) 810-1788
 Product Information: 800-877-TURN (Concord, California) 8:00 a.m. - 4:00 p.m. PST

2. Composition/Information on Ingredients

Ingredient	CAS Number	% (wt.)	LC50 (rat)	LD50 (rat)	TLV	STEL
Calcium Carbonate	1317-65-3	< 50	N/A	N/A	N/A	N/E
Vinyl Acetate Polymers	Not disclosed	< 40	N/A	N/A	N/A	N/A
Water	7732-18-5	< 25	N/A	N/A	N/E	N/E
Auxiliary Chemicals	N/A	< 5	N/A	20 - 34 g/Kg	50 ppm	N/A
Color Pigment	1309-37-1	< 0.5	N/A	N/A	N/A	N/A

3. Physical Properties

Appearance / Physical State	Red, viscous compound	Specific Gravity (@25°C)	1.40 - 1.50
Odour	Mild odour	Evaporation Rate	< 1
Odour Threshold	Slightly aromatic odour	Boiling Point (°C)	> 100
Vapour Pressure (mm Hg)	18.51880	Freezing Point (°C)	0
Vapour Density (Air = 1)	of Water vapor	pH	8.0 – 9.0
Coefficient of H2O/Oil Distrib	Not determined	VOC contents (g/L)	32.5

4. Fire and Explosion Data

Flammability	No
Means of Extinction	Normal fire fighting procedures should be followed to avoid inhalation of smokes and gases.
Special Fire-fighting Procedures	Firefighters should wear the usual protective gear use self-contained breathing apparatus.
Auto-ignition Temperature (°C)	N/A
Flash Point (°C) / Method	N/A
Upper Flammable Limit (% Volume)	N/A
Lower Flammable Limit (% Volume)	N/A
Sensitivity to Mechanical Impact	No
Sensitivity to Static Discharge	No
Hazardous Combustion Products	Carbon Monoxide, Carbon Dioxide, Aliphatic Hydrocarbons and Hydrocarbon Oxidation products.

5. Reactivity Data

Stability	Stable at normal condition
Condition of Reactivity	Contact with incompatible substances
Incompatible Materials	Reacts with mineral acids and alkalis
Hazardous Decomposition Products	Dried films forced to burn will produce: Carbon Monoxide, Carbon Dioxide, and hydrocarbon oxidation products.

MATERIAL SAFETY DATA SHEET

MSDS Name: GrabberGard EFC

Revision Date: August 30, 2012

6. Toxicological Properties

Effects of Acute Exposure to Product	Skin and eye irritation may occur after contact with the product.
Effects of Chronic Exposure to Product	None known
Exposure Limits	None known
Irritancy of Product	Slight on skin and eyes
Sensitization of Product	None known
Carcinogenicity	None known
Teratogenicity	None known
Reproductive Toxicity	None known

7. First Aid Measures

Eye Contact	Flush with large quantities of water gently for 15 minutes and get medical attention.
Skin Contact	Wash with soap and water.
Inhalation	Remove affected person away from source of exposure to fresh air and get medical attention IMMEDIATELY
Ingestion	Get medical attention IMMEDIATELY.

8. Preventive Measures

Engineering Controls	Standard industrial ventilation is recommended.
Personal Protective Equipment	Chemical safety glasses and gloves were required during normal use and handling.
Eye Protection (Specify)	Face shield or chemical goggles were recommended.
Skin Protection (Specify)	Chemical resistant nitrile, neoprene or rubber gloves were recommended if contact to the product directly.
Respiratory (Specify)	Respiratory protection is not normally required. Use NIOSH/MSHA approved respirator if condition warrant.
Other	

9. Precautions for Safe Handling and Use

Handling Procedure and Equipment	N/A
Storage Requirement	Material should be kept in a closed container and stored between 4 – 32°C (40 – 90°F)
Spill, Leak or Releases	Wear protective equipment during cleanup.
Waste Disposal	Care should be taken to ensure that the material or it's containers and disposed of in an approved facility, state, provincial and local regulations.
Special Shipping Instructions	DO NOT FREEZE

10. Regulation Information

WHMIS	Not controlled
HMIS	Health 1, Flammability 0, Reactivity 0
TDG Regulation	Not classified as a hazardous material.
TSCA	All ingredients of this product are on the inventory list.
DSL	All ingredients of this product are on the list.

MATERIAL SAFETY DATA SHEET

MSDS Name: GrabberGard IFC
Revision Date: August 30, 2012

11. Preparation Information	
Prepared by:	Chemical Laboratory, Passive Fire Protection Partners
Preparation Date:	11 March 2003
Telephone:	(604) 515-1788
Reason for Revision:	New formulation, rev 001, March 22, 2002 New format of MSDS, rev 002, September 16, 2004 Ingredient information updating, rev 003, November 10, 2006 MSDS reviewing, rev 004, December 30, 2008 Formulation updating, rev 005, August 24, 2009 Spelling mistake on Section of Precaution for Safe Handling and Use, rev 006, March 1, 2010 Formulation updating, rev007, January 3, 2011 Review, rev008, August 30, 2012
Revision Date:	August 30, 2012
Abbreviations Used:	% (wt.) = Weight Percentage ACGIH = American Conference of Governmental Industrial Hygienists CAS Number = Chemical Abstracts Series Number DSL = Domestic Substance List in Canada H = Hours HMIS = Hazardous Material Identification System IARC = International Agency for Research on Cancer LC50 = Lethal Concentration, 50% LD50 = Lethal Dose, 50% MSHA = Mine Safety and Health Administration N/A = Not Applicable or Not Available N/E = None Established NIOSH = The National Institute for Occupational Safety and Health NTP = National Toxicology Program OSHA = The Occupational Safety and Administration STEL = Short Term Exposure Limit TDG = Transportation of Dangerous Goods TLV = Threshold Limit Value TSCA = Toxic Substance Control Act in US VOC = Volatile Organic Compounds WHMIS = Workplace Hazardous Material Identification System
<p>This information is provided in good faith and is correct to the best of Grabber Construction Products' knowledge as of the date hereof; however, Grabber makes no representation as to its completeness or accuracy. Customers are encouraged to make their own determination as to the suitability of this product for their purpose prior to use. Grabber disclaims responsibility to damages of any kind resulting from the use of this information. THERE ARE NO WARRANTIES OR REPRESENTATIONS, EXPRESS OR IMPLIED, INCLUDING THOSE OF MERCHANTABILITY OR FITNESS FOR A PARTICULAR PURPOSE WITH RESPECT TO THIS INFORMATION OR TO THE PRODUCT IT DESCRIBES.</p>	

CAULKING INSTRUCTIONS - GRABBERGARD EFC

Equipment and Caulking Installations Instructions Using Caulking Applicator Guns



There are different types of caulking applicator guns available. The recommended procedure when using the different styles will be described in Sections A and B.

Section C will then describe the recommended procedures to follow to install the caulk and finish the job.

Section A – Applying Caulk in Plastic and Cardboard Fiber Foil Wrapped Cartridges

There are variety of applicator caulking guns available to do firestopping. We recommend using a smooth rod style rather than the less expensive ratchet rod type. When dispensing caulk from a 29 ounce-size cartridge, we recommend a rod type gun with at least a 12:1 thrust ratio. The higher thrust ratio means less hand fatigue since firestopping caulks are usually high viscous caulking. The higher thrust ratio will also help when the product becomes stiffer in the colder temperatures. (12:1 ration generates approximately 300 pound thrust)

For manual single component cartridge applicator guns.



Select the correct size manual drive frame-style cartridge gun for either the 10-ounce (300ml) or the larger 29-ounce (850ml) plastic or cardboard fiber foil wrapped tube type



Using a utility knife cut off the end of the plastic tip/nozzle to the desired opening size. The cut can be either straight across (90°) or angled (45°). Cutting too small of an opening will restrict the flow of material and a smaller bead size will result. The smaller the opening the higher the trigger action (pressure) required to move the material out of the tube.

On the 29 fl. oz. tubes, insert either a screwdriver or other pointed utensil into the plastic nozzle to puncture the membrane; which will allow the caulk material to flow.

CAULKING INSTRUCTIONS - GRABBERGARD EFC



Pull back the push rod of the frame-style caulking gun to its full extension.



Drop the cartridge into the frame insuring that the plastic nozzle of the cartridge is place through the opening in the end plate.



Repeatedly pull the trigger of the applicator guns until the push rod is advanced to the end of the cartridge. The caulk will begin to flow when some resistance is felt.



When the desired amount of material has been advanced, stop triggering; release the pressure by pressing the lever (tab) located at the back of the handle with your thumb. This causes the push rod to slip back stopping the flow of material.

REFER TO SECTION C TO COMPLETE THE INSTALLATION PROCEDURE.

CAULKING INSTRUCTIONS - GRABBERGARD EFC

Section B- Applying Caulk with Refillable Bulk Loading Applicator Gun



The caulking to be used is shipped in 5-gallon (18.9 liter) plastic tapered pails.



Advance the plunger and push the rod down to the end of the barrel. To begin the loading process, remove the front cap containing the nozzle.



With a utility knife, cut an opening in the plastic nozzle (cut can be straight across (90°) or angled (45°)).



Coat the threads at the end of the barrel with a solvent (oil) or water to prevent the accumulation of material.



Immerse the open end of the barrel into the material to a depth of approximately 1-inch. Move the immersed gun slightly around so the material will adhere and form an air seal.

CAULKING INSTRUCTIONS - GRABBERGARD EFC



Hold the barrel steady, grip the T-pull and slowly pull the push rod back drawing the material into the barrel. Pulling the rod back too quickly may result in air pockets and an incomplete fill.

Remove the gun from the pail of material and scrape off the excess amount that has accumulated on the barrel.

Replace the front cap and nozzle.

To stop the flow of product, stop triggering and depress the pressure and release tab on the handle.

Now you are ready to install the material into the openings and joints.



REFER TO SECTION C TO COMPLETE THE INSTALLATION PROCEDURE.

Section C – Installing Firestop Caulk

General Information

All firestopping installations must be performed in compliance with a tested and listed firestop system design. The testing laboratories like Underwriters Laboratories (UL) or Intertek (Warnock Hersey) publish these listings.

For the appropriate listing, consult the manufacturer's literature or the testing laboratories Fire Protection Directories and/ or their web sites.

The manufacturer recommends an individual who has been properly trained in the correct procedures should perform all firestop installations. The individual must be able to read and understand a tested firestop listing design.

The applicator should have the following materials and equipment to correctly and safely install firestop caulking.

- Safety Glasses
- Gloves
- Utility (box) knife
- Stainless Steel Spatula
- Cleaning rags
- Plastic spray water bottle (quart/liter) with finger pump trigger/nozzle

Areas to be firestopped should be clean, free from: water, excessive dirt, dust, debris and grease. For the best results, the ideal atmospheric temperatures and environment would be:

- Dry, 60°-75°F (15°C -24°C) & R.H. 50 %.

CAULKING INSTRUCTIONS - GRABBERGARD EFC

When the damming or fire insulation material is required, the following information should be considered before commencing.

- Backer rod used as a damming or support material should be installed into the opening in a thickness and compressed sufficiently as to not dislodge and fall out under normal building movement. Wrap the backer rod completely around the penetration(s) and recess it to accommodate the required amount of firestop caulk.
- Mineral wool when required, as an insulation material, it should be installed into the opening compressed to a thickness as to not dislodge nor fall out under normal building movement. The mineral wool, usually 4 pcf, should be installed to the compression required by the firestop listing. The orientation of the mineral wool is also very important and maybe the difference of the system being in compliance or not. For construction joints or through penetration in floor (horizontal) rated assemblies, the mineral wool or similar fibrous material should be installed with the lamination in a vertical orientation assemblies. The opposite is the rule of joints and through penetrations in wall (vertical) assemblies. Here the laminations should be placed in a horizontal orientation. Installing the mineral wool in these different lamination directions allows the material to be compressed to the density required for the firerating and building movement.
- Do not install mineral wool that is or has become wet i.e. exposure to water, rain, or snow.

Water base caulks adhere to some construction materials better than others. Applying a light mist of water to these surfaces can in some instances, help the bonding process. Mineral wool, is one of these materials, especially when it is in a vertical orientatation.

Tooling the installed material can be done in several ways:

- Dry tooling: After the material is put in place, using a spatula or other tool that has not been wetted with water, smooth it out.
- Wet tooling: After the material has been put in place, using a spatula or other tool that has been wetted with water, smooth it out.
- Wet tooling: After the material has been installed, lightly mist the material with water. Use a plastic water spray bottle, turn the nozzle to a mist spray orifice, hold the bottle approximately 10-12 inches (255-305mm) from the area. **DO NOT APPLY WATER TO THE MATERIAL IN A CONCENTRATED JET SPRAY.** This will apply too much water, causing the material to dilute and run out.

CAULKING INSTRUCTIONS - GRABBERGARD EFC

Caulking Penetrations

Install the correct amount of caulk material into the opening (annular space) around the service penetration to the depth/ thickness required. Make sure that caulking is in intimate contact with the substrate and the penetrating item. Once the caulk is in place, tool the material with a tooling utensil (spatula) to a smooth finish. This will push the installed material into areas not covered in the initial caulking procedure. It will also help to ensure a better bond with mating construction materials.

Caulking Construction Joints

Some construction joints do not require damming material or mineral wool to be used to affect a firestop system. When filler caulk material is the only component required, the installation must be installed in accordance with the listing being used. This usually requires the filler material to be installed into the gap/joint. Once the caulking has been trowelled or gunned in place, the installed material should be tooled into a smooth finish. Work the material to ensure no voids and air holes are left. This is particularly important when caulking to fireproofing materials. Cured fireproofing is very porous and the caulking must be tooled to it to ensure a tight seal and a secure mating surface system, refer to the procedures described above for the proper installation before applying the filler caulking material.

Note: All installation procedures of firestop caulk materials outlined in the proceeding information are water-based compounds.

Grabber Branch Locations

GRABBER Atlanta
Duluth, GA
Phone: 770-813-1332

GRABBER Jacksonville
Jacksonville, FL
Phone: 904-739-2760

GRABBER Northwest
Portland, OR
Phone: 503-467-5001

GRABBER Tampa
Tampa, FL
Phone: 813-249-2281

GRABBER California
Concord, CA
Phone: 925-687-6606

GRABBER Honolulu
Honolulu, HI
Phone: 808-836-1161

GRABBER Los Angeles
Santa Fe Springs, CA
Phone: 562-696-5122

GRABBER Texas
Dallas, TX
Phone: 972-470-9044

GRABBER Canada
Langley, British Columbia
Phone: 604-856-1444

GRABBER Miami
Miami, FL
Phone: 305-820-0975

GRABBER Ohio
Fairfield, OH
Phone: 513-874-9027

GRABBER Utah
Murray, UT
Phone: 801-266-4151

GRABBER Frederick
Frederick, MD 21703-7300
Phone: 301-371-0701

GRABBER Midwest
Maumee, OH
Phone: 419-794-8212

GRABBER Orlando
Orlando, FL
Phone: 407-297-7278

GRABBER Virginia
Chantilly, VA
Phone: 703-631-8770

GRABBER Ft. Myers
Ft. Myers, FL
Phone: 239-278-1888

GRABBER Missouri
Kansas City, MO
Phone: 816-931-8816

GRABBER San Diego
San Diego, CA
Phone: 858-292-6022

Grabber/Scorpion Fasteners
East Windsor, CT
Phone: 860-623-3600

GRABBER Houston
Houston, TX
Phone: 713-545-3918

GRABBER Northeast
Pennsauken, NJ
Phone: 856-662-2525

GRABBER Southeast
Pompano Beach, FL
Phone: 954-971-4730

Grabber Branch Locations

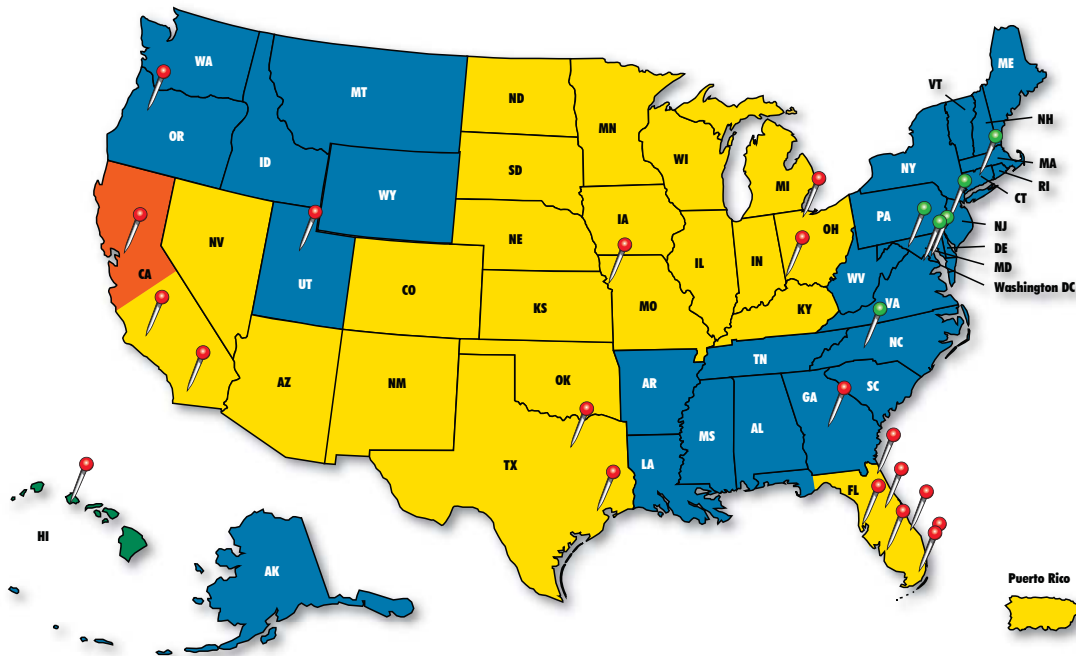

International Division
Phone: 925.687.6606

Home Centers
Phone: 800.606.6006

U.S. North Division
Phone: 800-241-3161

U.S. South Division
Phone: 800-925-0320

Grabber has you covered with more than just great fastening products. . .

To put it simply, Grabber can help you build a better product while simultaneously making you more money. Through constant innovation, Grabber continues to simplify the way you work by providing the best, most technologically advanced products available today.



Drywall Screws
Metal Framing Screws
Concrete Anchors
Pneumatic Nails

Fasten it

Grabber has a full line of fasteners for just about any application. From drywall screws to heavy gauge framing screws Grabber has what you need. Grabber invented the drywall screw and changed an entire industry. For the past 40 years Grabber has been the name you can trust for professional grade fasteners.



SuperDrive
Screw Guns
Chop Saws
Lasers

Drive it

Grabber's SuperDrive tool is designed to make driving screws faster and more accurate. Along with SuperDrive, Grabber offers many other tools that make your work easier including chop saws, routers, lasers and more.



Subfloor Adhesives
Drywall Adhesives
Acoustical Sealants
Fire Stopping Caulks

Caulk it

Grabber offers a complete line of caulks including sound control sealants, subfloor adhesives, drywall adhesives, insulation foam and more. Grabber also offers EFC and IFC fire stopping caulks and sealants.



NO-COAT® Stick Products
NO-COAT® ULTRAFLEX
HYDROTRIM®
Drywall Tape
Finishing Tools

Finish it

Grabber has everything you need for finishing your drywall projects. From fiberglass mesh tape and spark perforated drywall tape to the innovative No-Coat® structural drywall system, Grabber has what you need to do the job right.

Quality every step of the way. . . the reason the pros choose Grabber

Grabber sweats the small stuff, and that makes all the difference

The professional's first choice for over 40 years, Grabber premium quality screws are built for performance. Sharper threads mean a better driving experience so Grabber changes thread dies more frequently. Tight recesses mean screws are less likely to cam-out and bit tips will last longer so Grabber changes recess dies more frequently. Consistent heat treating means screw heads will be less likely to pop off, so Grabber heat treats fewer screws at a time ensuring more even heat treatment. These are small things most people don't notice, but they are also small things that make the difference between average fasteners and professional grade fasteners.

Grabber is an international distributor of premium fasteners and fastening systems for wood, metal, and drywall applications in the commercial and residential construction markets. Grabber is home to the Deckmaster® Hidden Fastening System, the patented LOX® Drive System, and the SuperDrive Auto-Feed Fastening System. Grabber also distributes a wide range of proprietary tools and accessories, various equipment, and building materials to the construction industry.

Grabber screws and drywall nails are ICC ES (International Code Council Evaluation Service) evaluated, and engineered to meet or exceed the specifications for use, as prescribed in UBC 1997, IBC 2006, IRC 2006, IBC 2009, and IRC 2009. ASTM reports, approvals, shear, pullout and other technical information is available at www.grabberman.com

Grabber screws and nails are produced in an ISO 9001 and ISO 14001 approved and certified manufacturing environments. Grabber also supports a complete line of US manufactured construction fasteners that meet "Buy American" and the "American Reinvestment and Recovery Act" requirements. GrabberGard® exterior grade coated fasteners are rated for use in ACQ, pressure and fire treated lumber.



GRABBER
CONSTRUCTION PRODUCTS

www.grabberman.com

**Visit www.grabberman.com or
call 800-477-8876
to find a dealer near you.**

