

DESCRIPTION

- ◆ Multi-step system to maintain and seal metal roofs
- ◆ For use on slopes >1/2":12
- ◆ Energy Star® and reduced VOC products available
- ◆ 5, 10 & 10+5 year warranty options available
- ◆ Special treatment for seams, laps and fasteners
- ◆ Provides overall protection from corrosion

INSERT "PART 1 –GENERAL" and Henry Product Data Sheets are part of this specification.

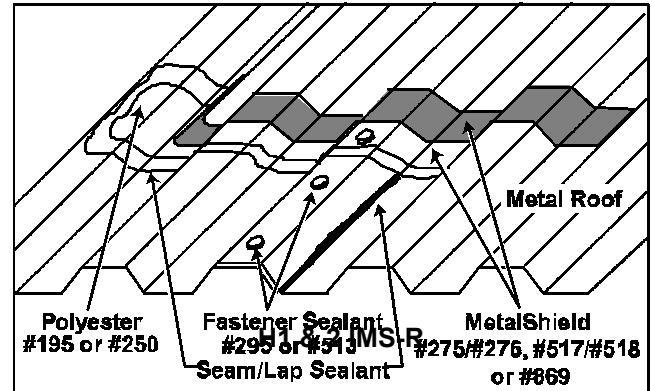

1.01 GENERAL

SCOPE OF WORK (Edit as required)

- A. Remove old mastic repairs over and adjacent to laps, seams and fasteners
- B. Remove any other foreign materials that will prevent MetalShield™ from adhering or creating a leak free roof system.
- C. Reattach loose metal, laps and gutters with new self-sealing fasteners.
- D. Replace damaged, weakened or corroded panels
- E. Replace damaged translucent panels and skylights.
- F. Re-secure or replace ineffective fasteners
- G. Remove non-functional penetrations/curbs and patch or install new panels
- H. Replace damaged or missing foam closures
- I. Pressure wash all roof surfaces and gutters
- J. Reseal all pipe boots, vents, gutters, AC units and roof penetrations.
- K. Treat skylight surfaces and seal.
- L. Treat surface rust
- M. Seal all exposed fasteners
- N. Treat panel laps and seams
- O. Repair or replace gutters
- P. Apply reflective coating on entire roof surface

PART 2 – PRODUCTS

2.01 ACCEPTABLE MANUFACTURERS

- A. Materials manufactured or supplied by Henry Company, Huntington Park, CA 90255. (323) 583-5000. Or Tech Service at (800) 486-1278.

2.02 PRODUCT DELIVERY

- A. Shall be in sealed containers with original labels intact.

2.03 SYSTEM DESCRIPTION (Select 1)

- A. **Rubber Based MetalShield™ (H2-IMS-R/S)**
Suitable for all areas except VOC restricted areas.
Applied in 2 coats @1.5 gallons per 100 ft.²/coat.

B. Water-Based MetalShield™ (H2-IMS-R/W)

ENERGY STAR® QUALIFIED
Suitable for all areas including VOC restricted regions.
Applied in 2 coats @1.5 gallon per 100 ft.²/coat.

10-year Warranty Option available

- a. #276 MetalShield base coat – Gray
- b. #275 MetalShield top coat – White
- c. #523 Acrylic Rust Inhibitor
- d. #513 Flashing Compound or
- e. #195 or #250 Polyester Reinforcement

C. Elastomeric Aluminum Coating #869 (H1-IMS-R)

ENERGY STAR QUALIFIED
Suitable for all areas including VOC restricted areas.

Applied in one coat @1.5 gallons per 100 ft.².
5-year Warranty Option available.

- a. #869 Elastomeric Aluminum coating
 - b. #104* or #103 Primer/Rust Inhibitor
 - c. #295* Seam Sealer or
 - d. #195 or #250 Polyester Reinforcement
- * Not for use in VOC restricted Regions

2.04 MATERIALS

- A. FASTENER SEALANT – (Select 1)
approximately 750 fasteners per gallon
 1. #295 Seam Sealer
 2. #513 Flashing Compound
- B. SEAM/LAP SEALANT – (select 1) 25 lin. ft. per gallon for 6" wide seams; 35 lin. ft. per gallon for 4" wide seams; 70 lin. ft. per gallon for 1/2" bead flow coat #295 only.
 1. #295 Seam Sealer
 2. #513 Flashing Compound
- C. REINFORCEMENT (Select 1)
 1. #195 or #250 Polyester – 4" wide strips
- D. REFLECTIVE SURFACING (Select 1)

1. Rubber based MetalShield Elastomeric Roof Coating – #517 White & #518 Gray
 2. Water based MetalShield Elastomeric Roof Coating – #275 White & #276 Gray
 3. #869 Elastomeric Aluminum coating.
- E. MISCELLANEOUS PRODUCTS
1. Approved self-drilling mechanical fasteners with self-sealing washers. One diameter larger than original fastener.
 2. Approved skylight panel sealer.
 3. Pre-formed foam closures matching panel profile or spray-in-place urethane foam, field cut and formed to profile.
 4. #176 PondPatch

PART 3 – APPLICATION

3.01 GENERAL

- A. Henry Company's General Requirements and Product Data are a part of this specification.

3.02 EXAMINATION

- A. Inspect metal surfaces and advise Owner's Representative of any corrections required before proceeding with roofing.

3.03 PREPARATION

- A. Reattach loose metal or excessive gaps with new self-drilling fasteners with self-sealing washers.
- B. Replace missing and tighten all exposed fasteners. Replace stripped fasteners with oversized of similar design as original.
- C. Replace damaged, dried, cracked or missing foam closures with either pre-formed closures matching panel profile or field install spray urethane foam, cut and formed to profile at gutter/roof panel overhang. All closures to be sealed with 1/4" bead of seam sealer to metal. Foam each high rib void at end panels where overhangs gutters.
- D. Pressure wash roof surface with water using a minimum working pressure of 2,000 psi to remove all dirt, dust, and waste products including, but not limited to oil, rust, scale, chalkiness and unstable portions of existing coating, rice dust, solvent, grease, animal fats, etc.

3.04 FASTENER SEALING

- A. Encapsulate each fastener with 1" diameter (2.5 cm) cap #295 Seam Sealer or #513 Flashing Compound. Allow to cure prior to applying reflective coating.

3.05 SEALING SEAMS/LAPS/SKYLIGHTS

- A. Metal Seam Sealer: laps over 1/8" (ide, brush apply 4" or 6" wide by 1/16" thick along seam and immediately embed 4" or 6" polyester respectively, then surface with second application of equal volume. Laps under 1/8" wide, "flow coat" via bulk pump or spray rig without tip, 1/2" bead up-slope of lap and allow sealer to flow over lap, bridging both sides equally. Polyester

reinforcement is not required in this situation.

- B. Skylight panels to be cleaned and inspected for structural strength. Defective panels should be noted to owner in writing prior to bid by contractor and replacement noted as separate line item. All existing mastic to be scraped clean and removed. Fasteners to be sealed as above, and side laps caulked with 1/8" min. bead of specified fastener and seam sealer on both sides of cinch bar to effect watertight seal. Coat with approved skylight panel sealer.

3.06 RUST TREATMENT

- A. Scaling rust to be wire brushed or sanded until smooth, cleaned and treated with specified Rust Inhibitor Primer. Allow to completely dry.

3.07 GUTTER AND DRAINS

- A. All gutters, scuppers, and roof drains must be cleaned, repaired or replaced and securely attached to structure. Insides of gutters to receive rust treatment with MetalShield Primer after joints are sealed with specified seam treatment.

3.08 REFLECTIVE COATING

- A. Cover skylights, ventilator units and all other areas not scheduled for coating. *Use caution to avoid introducing vapors or fumes into occupied building spaces.*
- B. Hose down surface to remove any accumulated surface dust or dirt. Allow to dry completely. Repeat procedure as required.
- C. Apply [MetalShield Rubber Based (#517/#518)] or [Water Based Elastomeric Coating (#275/#276)] in two coats at a minimum 1.5 gallons per 100 sq. ft. per coat based upon specified coating system. The base or first coat is usually gray and the final or weathering surface coat is white. Allow minimum 24 hour curing time.
- D. Apply second coat at right angles to first to obtain uniform coverage. Follow important instructions and limitations on manufacturer's product data sheet.
- E. Apply #869 Elastomeric Aluminum Coating in one coat at a rate of 1.5 gallons per 100 sq.ft. Apply in parallel strokes.