

ICC-ES Evaluation Report

ESR-3520

Reissued August 2025

Revised November 2025

Subject to renewal August 2027

This report also contains:

- [City of LA Supplement](#)

- [FL Supplement w/ HVHZ](#)

ICC-ES Evaluation Reports are not to be construed as representing aesthetics or any other attributes not specifically addressed, nor are they to be construed as an endorsement of the subject of the report or a recommendation for its use. There is no warranty by ICC Evaluation Service, LLC, express or implied, as to any finding or other matter in this report, or as to any product covered by the report.

Copyright © 2025 ICC Evaluation Service, LLC. All rights reserved.

<p>DIVISION: 03 00 00— CONCRETE</p> <p>Section: 03 15 19— Cast-In Concrete Anchors</p> <p>Section: 03 16 00— Concrete Anchors</p>	<p>REPORT HOLDER:</p> <p>HILTI, INC.</p>	<p>EVALUATION SUBJECT:</p> <p>HILTI ANCHOR CHANNEL SYSTEMS: HILTI ANCHOR CHANNELS HAC(-V) WITH HILTI CHANNEL BOLTS HBC-B, HBC-C AND HBC-C-N AND HILTI ANCHOR CHANNELS HAC(-V)-T WITH HILTI CHANNEL BOLTS HBC-T IN CRACKED AND UNCRACKED CONCRETE</p>	
--	--	--	---

1.0 EVALUATION SCOPE

Compliance with the following codes:

- 2024, 2021, 2018 and 2015 [International Building Code® \(IBC\)](#)
- 2024, 2021, 2018 and 2015 [International Residential Code \(IRC\)](#)
- 2013 *Abu Dhabi International Building Code (ADIBC)*†

†The ADIBC is based on the 2009 IBC as referenced under the ADIBC.

Main references of this report are for the 2024 IBC and IRC. See [Table 9](#) and [Table 10](#) for applicable sections of the code for previous IBC and IRC editions.

Property evaluated:

- Structural

2.0 USES

The four Hilti anchor channel systems described in this report include the following:

- Hilti serrated anchor channels (HAC-(V)(-T) 30F) with serrated Hilti channel bolts (HBC-B M10 4.6F, HBC-B M10 4.6G, HBC-B M12 4.6F, HBC-B M12 4.6G).
- Hilti anchor channels (HAC-V 35F, HAC-(V) 40F, HAC-(V) 50F, HAC-V 50 Rebar XTS, HAC-(V) 60F, HAC-(V) 70F, HAC-V 70 Rebar XTS) with Hilti channel bolts (HBC-C M12 8.8F, HBC-C M12 8.8G, HBC-C M16 4.6F, HBC-C M16 50R, HBC-C M16 8.8F, HBC-C M16 8.8G, HBC-C M20 8.8F, HBC-C M20 8.8G).
- Hilti anchor channels (HAC-V 35F, HAC-(V) 40F, HAC-(V) 50F, HAC-V 50 Rebar XTS, HAC-(V) 60F, HAC-(V) 70F, HAC-V 70 Rebar XTS) with locking Hilti channel bolts (HBC-C-N M12 8.8F, HBC-C-N M16 8.8F, HBC-C-N M20 8.8F). Hilti serrated anchor channels (HAC-(V)-T 50F, HAC-V-T 50 Rebar XTS, HAC-(V)-T 70F, HAC-V-T 70 Rebar XTS) with serrated Hilti channel bolts (HBC-T M12 8.8F, HBC-T M16 8.8F, HBC-T M20 8.8F).

Hilti serrated anchor channels (HAC-(V)(-T) 30F) with serrated Hilti channel bolts (HBC-B M10 4.6F, HBC-B M10 4.6G and HBC-B M12 4.6G) and Hilti anchor channels (HAC-V 35F, HAC-(V) 40F, HAC-(V) 50F, HAC-V 50 Rebar XTS, HAC-(V) 60F,

HAC-(V) 70F, HAC-V 70 Rebar XTS) with Hilti channel bolts (HBC-C M12 8.8F, HBC-C M12 8.8G, HBC-C M16 4.6F, HBC-C M16 50R, HBC-C M16 8.8F, HBC-C M16 8.8G, HBC-C M20 8.8F, HBC-C M20 8.8G) are used for anchorage in concrete to resist static, wind, and seismic (IBC Seismic Design Categories A and B) tension loads (N_{ua}) and shear loads perpendicular to the longitudinal channel axis ($V_{ua,y}$) or any combination of these loads applied at any location between the outermost anchors of the anchor channel in accordance with [Figure 2-1](#) of this report.

Hilti serrated anchor channels (HAC-(V)(-T) 30F) with serrated Hilti channel bolts (HBC-B M12 4.6F) and Hilti anchor channels (HAC-V 35F, HAC-(V) 40F, HAC-(V) 50F, HAC-V 50 Rebar XTS, HAC-(V) 60F, HAC-(V) 70F, HAC-V 70 Rebar XTS) with locking Hilti channel bolts (HBC-C-N M12 8.8F, HBC-C-N M16 8.8F, HBC-C-N M20 8.8F) and Hilti serrated anchor channels (HAC-(V)-T 50F, HAC-V-T 50 Rebar XTS, HAC-(V)-T 70F, HAC-V(-T) 70 Rebar XTS) with serrated Hilti channel bolts (HBC-T M12 8.8F, HBC-T M16 8.8F, HBC-T M20 8.8F) are used for anchorage in concrete to resist static, wind, and seismic (IBC Seismic Design Categories A through F) tension loads (N_{ua}) and shear loads perpendicular to the longitudinal channel axis ($V_{ua,y}$), shear loads acting in the direction of the longitudinal channel axis ($V_{ua,x}$) or any combination of these loads applied at any location between the outermost anchors of the anchor channel in accordance with [Figure 2-1](#) of this report.

As an alternative to the second system described in the first paragraph of Section 2.0, above, Hilti anchor channels (HAC-(V) 50F, HAC-V 50 Rebar XTS, HAC-(V) 60F, HAC-(V) 70F, HAC-V 70 Rebar XTS) with Hilti channel bolts (HBC-C M16 8.8F, HBC-C M16 8.8G, HBC-C M20 8.8F, HBC-C M20 8.8G), used in conjunction with Hilti HIT-HY 100 adhesive are used for anchorage in concrete to resist static, wind, and seismic (IBC Seismic Design Categories C through F) tension loads (N_{ua}) and shear loads perpendicular to the longitudinal channel axis ($V_{ua,y}$), shear loads acting in the direction of the longitudinal channel axis ($V_{ua,x}$) or any combination of these loads applied at any location in a distance of 23/4 inches (70 mm) or greater to the outermost anchors of the anchor channel in accordance with [Figure 2-1](#) of this report.

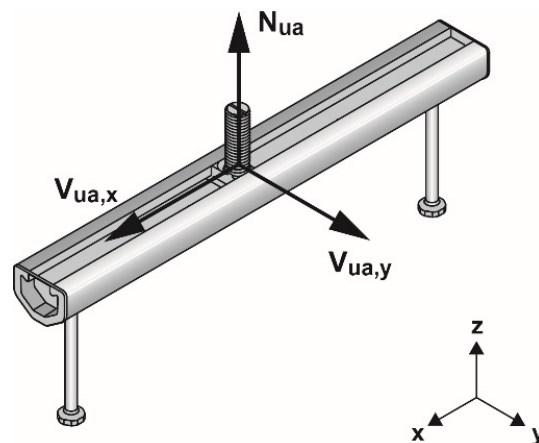

Tension load N_{ua} : z-direction (in direction of anchor)

Shear load $V_{ua,y}$: y-direction (perpendicular to longitudinal axis of channel)

Longitudinal load $V_{ua,x}$: x-direction (in direction of longitudinal axis of channel)

Figure 2-1: Load directions covered by this report

Transfer of tension loads takes place via interlock between the channel bolt and the channel lips, bending of the channel, tension in the anchors, and mechanical interlock between the anchors and the concrete. Shear loads perpendicular to the longitudinal channel axis are transferred by the anchors and by compression between the side of the channel and the concrete. However, for reasons of simplicity, it is assumed that the shear loads are transferred by the anchors only. Shear loads acting in the direction of the longitudinal channel axis are transferred as described in one of the following cases:

- HBC-B and HBC-T via mechanical interlock between the matching serrations of the channel bolt and the channel lips, and the interaction between the anchors and the concrete.

- HBC-C-N via mechanical interlock between the channel bolt and the channel profile by notches in the smooth channel lips and the interaction between the anchors and the concrete.
- HBC-C via mechanical interlock between Hilti HIT-HY100 adhesive and the rivet (connection between anchor and channel profile mounted through the channel back), and the interaction between the anchors and the concrete.

The use is limited to cracked or uncracked normal-weight and lightweight concrete having a specified compressive strength, f_c , of 2,500 psi to 10,000 psi (17.2 MPa to 69.0 MPa) [minimum of 24 MPa is required under ADIBC Appendix L, Section 5.1.1].

Anchor channel systems are alternatives to cast-in-place anchors described in Section 1901.3 of the 2024 IBC. They may also be used where an engineered design is permitted in accordance with IRC Section R301.1.3.

3.0 DESCRIPTION

3.1 HAC(-V) (-T) anchor channel systems:

The Hilti anchor channel systems ([Figure 8-3](#)) consist of a V-shaped carbon steel channel profile with at least two round headed anchors or deformed reinforcing bars bolted to the channel back, channel bolt(s) corresponding to the anchor channel, and matching nut(s) and washer(s) for the channel bolt(s). The (-T) nomenclature is used to indicate a serrated anchor channel. The (-V) nomenclature is used for anchor channel systems with a higher strength. The maximum number of anchors per channel is not limited. The appropriate channel bolts ([Figure 8-3](#)) are placed in the anchor channel ([Figure 2-1](#)). Geometric parameters are shown in [Figure 8-2](#) and [Figure 8-4](#), and are given in [Tables 8-1](#) and [8-2](#) of this report.

Steel specifications for the channels, anchors, channel bolts, and matching nuts and washers of the channel bolts are given in [Table 8-19](#) of this report. Hex nut and washer material type and grade must match the channel bolts.

3.2 Concrete:

Normal-weight and lightweight concrete shall comply with Sections 1903 and 1905 of the IBC.

4.0 DESIGN AND INSTALLATION

4.1 Strength Design:

4.1.1 General:

The design strength of anchor channel systems under the 2024 IBC, must be determined in accordance with ACI 318-19 Chapter 17 and this report.

4.1.2 Determination of forces acting on anchor channels:

4.1.2.1 General:

Anchor channels shall be designed for critical effects of factored loads as determined by elastic analysis taking into account the elastic support by anchors and the partial restraint of the channel ends by concrete compression stresses. As an alternative, the load distribution method in accordance with Sections 4.1.2.2, 4.1.2.3, and 4.1.2.4 to calculate the tension and shear loads on anchors shall be permitted. Design of adjacent anchor channels shall be in accordance with Section 4.1.2.6.

4.1.2.2 Tension loads:

The tension loads, $N_{ua,i}^a$, on an anchor due to a tension load, N_{ua} , acting on the channel shall be computed in accordance with Eq. (1). An example for the calculation of the tension loads acting on the anchors is given in [Figure 4-1](#).

$$N_{ua,i}^a = k \cdot A_i' \cdot N_{ua} \quad (1)$$

where:

A_i' = ordinate at the position of the anchor i assuming a triangle with the unit height at the position of load N_{ua} and the base length $2\ell_{in}$ with ℓ_{in} determined in accordance with Eq. (3). Examples are provided in [Figure 4-1](#).

$$k = 1 / \sum A_i' \quad (2)$$

$$\ell_{in} = 4.93(I_y)^{0.05} \cdot \sqrt{s} \geq s, \text{ in.} \tag{3}$$

$$\ell_{in} = 13(I_y)^{0.05} \cdot \sqrt{s} \geq s, \text{ mm}$$

s = anchor spacing, in. (mm)

N_{ua} = factored tension load on channel bolt, lb (N)

I_y = the moment of inertia of the channel shall be taken from [Tables 8-1](#) and [8-2](#) of this report.

If several tension loads are simultaneously acting on the channel, a linear superimposition of the anchor forces for all loads shall be assumed. If the exact position of the load on the channel is not known, the most unfavorable loading position shall be assumed for each failure mode (e.g. load acting over an anchor for the case of failure of an anchor by steel rupture or pull-out and load acting between anchors in the case of bending failure of the channel).

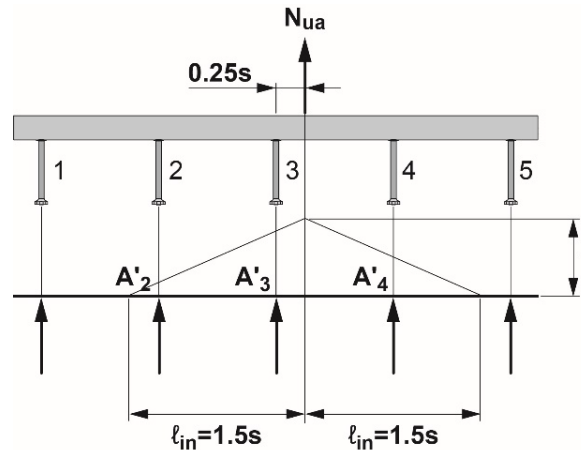

$$A'_2 = \frac{0.25s}{\ell_{in}} = \frac{1}{6} \qquad N_{ua,1}^a = N_{ua,5}^a = 0$$

$$A'_3 = \frac{1.25s}{\ell_{in}} = \frac{5}{6} \qquad N_{ua,2}^a = \frac{1}{6} \cdot \frac{2}{3} \cdot N_{ua} = \frac{1}{9} N_{ua}$$

$$A'_4 = \frac{0.75s}{\ell_{in}} = \frac{1}{2} \qquad N_{ua,3}^a = \frac{5}{6} \cdot \frac{2}{3} \cdot N_{ua} = \frac{5}{9} N_{ua}$$

$$k = \frac{1}{A'_2 + A'_3 + A'_4} = \frac{2}{3} \qquad N_{ua,4}^a = \frac{1}{2} \cdot \frac{2}{3} \cdot N_{ua} = \frac{1}{3} N_{ua}$$

Figure 4-1: Example for the calculation of anchor forces in accordance with the triangular load distribution method for an anchor channel with five anchors.

The influence length is assumed as $\ell_{in} = 1.5s$

The bending moment, $M_{u,flex}$, on the channel due to tension loads acting on the channel shall be computed assuming a simply supported single span beam with a span length equal to the anchor spacing.

4.1.2.3 Shear loads acting on the channel perpendicular to its longitudinal axis:

The shear load, $V_{ua,y,i}^a$, on an anchor due to a shear load $V_{ua,y}$ acting on the channel perpendicular to its longitudinal axis shall be computed in accordance with Section 4.1.2.2 replacing N_{ua} in Eq. (1) by $V_{ua,y}$.

4.1.2.4 Shear loads acting on the channel in direction of the longitudinal channel axis:

The shear load, $V_{ua,x,i}^a$, on an anchor due to a shear load, $V_{ua,x}$, acting on the channel in direction of the longitudinal channel axis shall be computed as follows:

For the verification of the strength of the anchor channel for failure of the anchor or failure of the connection between anchor and channel, pryout failure, and concrete edge failure in case of anchor channels arranged parallel to the edge without corner effects, the shear load, $V_{ua,x}$, shall be equally distributed to all anchors for anchor channels with not more than three anchors or to three anchors for anchor channels with more than three anchors (as illustrated in [Figure 4-3](#)). The shear load, $V_{ua,x}$, shall be distributed to those three anchors

that result in the most unfavorable design condition (in the example given in [Figure 4-3](#) the shear load, $V_{ua,x}$, shall be distributed to the anchors 10 to 12).

For the verification of the strength of the anchor channel for concrete edge failure in case of anchor channels arranged perpendicular to the edge and in case of anchor channels arranged parallel to the edge with corner effects, the shear load, $V_{ua,x}$, shall be equally distributed to all anchors for anchor channels with not more than three anchors or to the three anchors closest to the edge or corner for anchor channels with more than three anchors (as illustrated in [Figure 4-4](#)).

4.1.2.5 Forces related to anchor reinforcement:

If tension loads are acting on the anchor channel, the factored tension forces of the anchor reinforcement for one anchor shall be computed for the factored tension load, $N^{0}_{ua,i}$, of the anchor assuming a strut-and-tie model.

If a shear load, $V_{ua,y}$, is acting on the anchor channel, the resultant factored tension force of the anchor reinforcement $N_{ua,re}$, shall be computed by Eq. (4).

$$N_{ua,re} = V_{ua,y} \left(\frac{e_s}{z} + 1 \right) , lb (N) \tag{4}$$

where, as illustrated in [Figure 4-2](#):

e_s = distance between reinforcement and shear force acting on the anchor channel, in. (mm)

z = $0.85 \cdot (h - h_{ch} - 0.5d_a) \leq \min(2h_{ef}, 2c_{a1})$

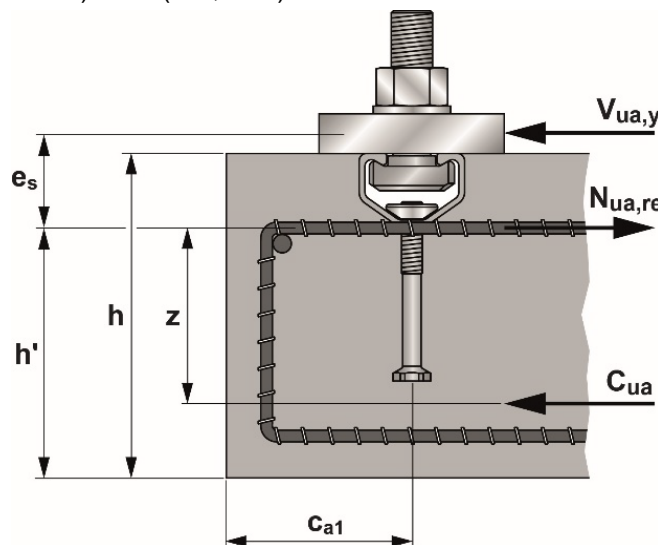

Figure 4-2: Anchor reinforcement to resist shear loads

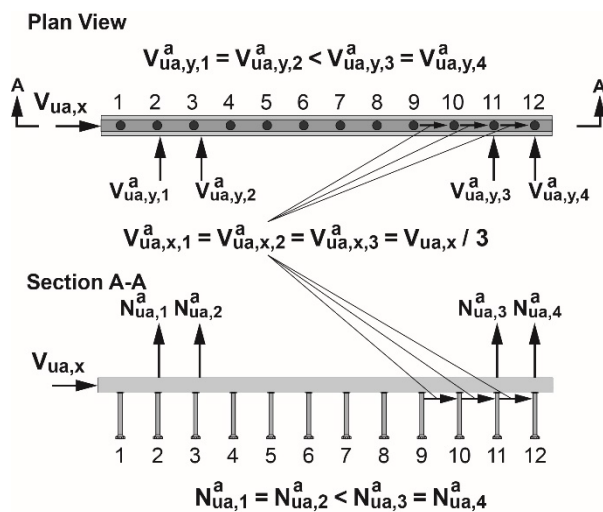
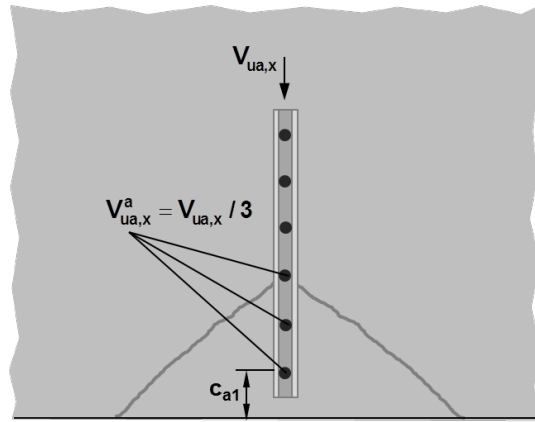
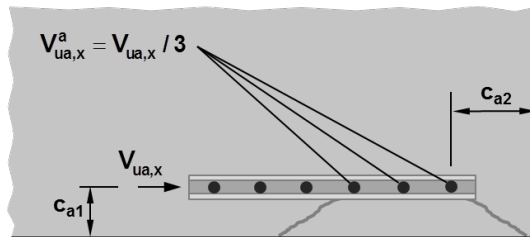

Figure 4-3: Example for the calculation of anchor forces in case of anchor channels with 12 anchors loaded in shear longitudinal to the channel axis for steel and pryout failure



a) anchor channel installed perpendicular to the edge



b) anchor channel installed parallel to the edge

Figure 4-4: Example for the calculation of anchor channels with 6 anchors loaded in shear longitudinal to the channel axis for concrete edge failure

4.1.2.6 Adjacent anchor channels:

Anchor channels may be arranged as shown in [Figure 4-5](#). Adjacent anchor channels must be of same size and consist of anchors with same type and embedment depth. In case of anchor channel configurations according to [Figure 4-5b](#) and [Figure 4-5c](#) loaded in shear in any direction, the load shall be transferred to the adjacent anchor channels by a single plate (see [Figure 4-6](#)).

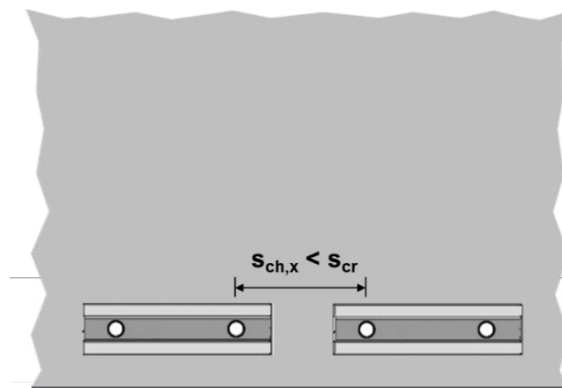

a) anchor channel in linear arrangement

Figure 4-5: Included configurations of adjacent anchor channels

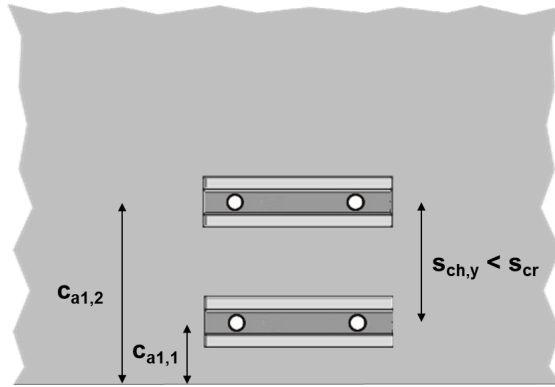

b) adjacent anchor channels arranged parallel to edge ($n_1 = 2$)

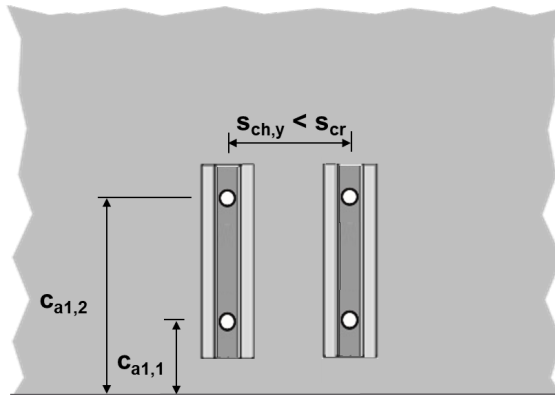

c) adjacent anchor channels arranged perpendicular to edge ($n_1 = 2$)

Figure 4-5 (cont.): Included configurations of adjacent anchor channels

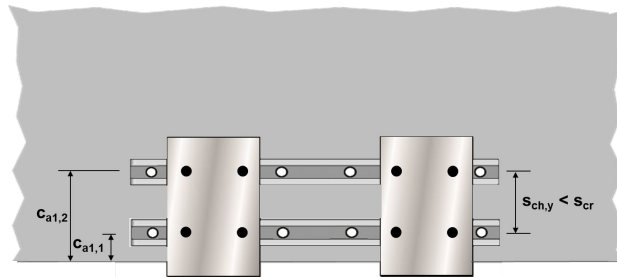

Figure 4-6: Permissible configuration with multiple attachments ($n_1 = 2$); two plates shown. Shear transferred between adjacent anchor channels by adjacent plates

4.1.3 Requirements for design strength:

4.1.3.1 General:

The design strength of anchor channel systems under the 2024 IBC as well as Section R301.1.3 of the 2024 IRC must be determined in accordance with ACI 318-19 Chapter 17 and this report.

Design parameters provided in [Table 8-1](#) through [Table 8-18](#) in this report and references to ACI 318 are based on the 2024 IBC (ACI 318-19) unless noted otherwise in Sections 4.1 and 4.2 of this report.

The strength design must comply with ACI 318-19 17.5.1.2, except as required in ACI 318-19 17.10.

Design parameters are provided in [Table 8-1](#) through [Table 8-18](#) of this report. Strength reduction factors, ϕ , as given in ACI 318-19 17.5.3 and in the tables of this report must be used for load combinations calculated in accordance with Section 1605.1 of the 2024 IBC and Section 5.3 of ACI 318-19.

In Table 17.5.2 of ACI 318-19, ϕN_n and ϕV_n are the lowest design strengths determined from all appropriate failure modes. ϕN_n is the lowest design strength in tension of an anchor channel system determined from consideration of ϕN_{sa} , ϕN_{sc} , ϕN_{sl} , ϕN_{ss} , $\phi M_{s,flex}$, ϕN_{cb} , (anchor channels without anchor reinforcement to take up tension loads) or ϕN_{ca} (anchor channels with anchor reinforcement to take up tension loads), ϕN_{pn} , and ϕN_{sb} .

$\phi V_{n,y}$ is the lowest design strength in shear perpendicular to the axis of an anchor channel as determined from $\phi V_{sa,y}$, $\phi V_{sc,y}$, ϕV_{ss} , $\phi V_{ss,M}$, $\phi V_{sl,y}$, $\phi V_{cb,y}$ (anchor channel without anchor reinforcement to take up shear loads perpendicular to the channel axis), or $\phi V_{ca,y}$ (anchor channel with anchor reinforcement to take up shear loads perpendicular to the channel axis) and $\phi V_{cp,y}$. $\phi V_{n,x}$ is the lowest design strength in shear acting longitudinal to the channel axis of an anchor channel as determined from $\phi V_{sa,x}$, $\phi V_{sc,x}$, ϕV_{ss} , $\phi V_{ss,M}$, $\phi V_{sl,x}$, $\phi V_{cb,x}$ (anchor channel with or without anchor reinforcement to take up shear loads in the direction of the longitudinal channel axis) and $\phi V_{cp,x}$. The design strengths for all anchors of an anchor channel shall be determined.

4.1.3.2 Tension loads:

4.1.3.2.1 Required verifications:

Following verifications are required:

- Steel Failure: Steel strength of anchor, strength of connection between anchor and channel, strength for local failure of channel lip, strength of channel bolt, bending strength of channel, see Section 4.1.3.2.2.
- Concrete breakout strength of anchor in tension, see Section 4.1.3.2.3.
- Pullout strength of anchor channel in tension, see Section 4.1.3.2.4.
- Concrete side-face blowout strength of anchor channel in tension, see Section 4.1.3.2.5.

4.1.3.2.2 Steel Strength in Tension:

The nominal strength, N_{sa} , of a single anchor must be taken from [Tables 8-4](#) and [8-5](#) of this report.

The nominal strength, N_{sc} , of the connection between anchor and anchor channel must be taken from [Tables 8-4](#), and [8-5](#) of this report. The nominal strength of the channel lips to take up tension loads transmitted by a channel bolt, N_{sl} , must be taken from [Tables 8-4](#) and [8-5](#) of this report. This value is valid only if the center-to-center distance between the channel bolt under consideration and adjacent channel bolts, s_{chb} , is at least $s_{chb,cr}$. If this requirement is not met, then the value N_{sl} given in [Tables 8-4](#) and [8-5](#) must be reduced by the factor

$$1 + \sum_{i=2}^{n+1} \left[\left(1 - \frac{s_{chb,i}}{s_{chb,cr}} \right)^2 \cdot \frac{N_{ua,i}^b}{N_{ua,1}^b} \right] \quad (5)$$

where the center-to-center spacing between channel bolts shall not be less than 3-times the bolt diameter d_s . The value of $s_{chb,cr}$ shall be taken as $2b_{ch}$ (see [Figure 8-4](#) and [Figure 8-5](#)).

The nominal strength of the channel bolt, N_{ss} , must be taken from [Table 8-17](#) of this report.

The nominal bending strength of the anchor channel, $M_{s,flex}$, must be taken from [Tables 8-4](#) and [8-5](#) of this report.

4.1.3.2.3 Concrete Breakout Strength in Tension:

The nominal concrete breakout strength, N_{cb} , of a single anchor in tension of an anchor channel shall be determined in accordance with Eq. (6).

$$N_{cb} = N_b \cdot \psi_{s,N} \cdot \psi_{ed,N} \cdot \psi_{co,N} \cdot \psi_{c,N} \cdot \psi_{cp,N}, lb (N) \quad (6)$$

Where anchors consist of deformed reinforcing bars and the minimum spacing requirements in [Table 8-2](#) are met, verification for concrete breakout is not required provided that the reinforcing bars are lap sliced with reinforcing bars in the member according to the requirements of ACI 318 -19 Section 25.5.

The basic concrete breakout strength of a single anchor in tension in cracked concrete, N_b , shall be determined in accordance with Eq. (7).

$$N_b = 24 \cdot \lambda \cdot \alpha_{ch,N} \cdot \sqrt{f'_c} \cdot h_{ef}^{1.5}, lbf \quad (7)$$

$$N_b = 10 \cdot \lambda \cdot \alpha_{ch,N} \cdot \sqrt{f'_c} \cdot h_{ef}^{1.5}, N$$

where:

$$\alpha_{ch,N} = \left(\frac{h_{ef}}{7.1} \right)^{0.15} \leq 1 \quad (\text{inch-pound units})$$

$$\alpha_{ch,N} = \left(\frac{h_{ef}}{180} \right)^{0.15} \leq 1 \quad (\text{SI-units}) \quad (8)$$

Where anchor channels with $h_{ef} > 7.1$ in. (180 mm) are located in an application with three or more edges (as illustrated in [Figure 4-7](#)) with edge distances less than $c_{cr,N}$ ($c_{cr,N}$ in accordance with Eq. (14)) from the anchor under consideration, the values of h_{ef} used in Eq. (7), (8), and (11) may be reduced to $h_{ef,red}$ in accordance with Eq. (9).

$$h_{ef,red} = \max\left(\frac{c_{a,max}}{c_{cr,N}} \cdot h_{ef}; \frac{s}{s_{cr,N}} \cdot h_{ef}\right), \text{ in. (mm)} \quad (9)$$

where:

$c_{a,max}$ = maximum value of edge or corner distance, in. (mm)

The values $c_{cr,N}$ and $s_{cr,N}$ in Eq. (9) shall be computed with h_{ef} .

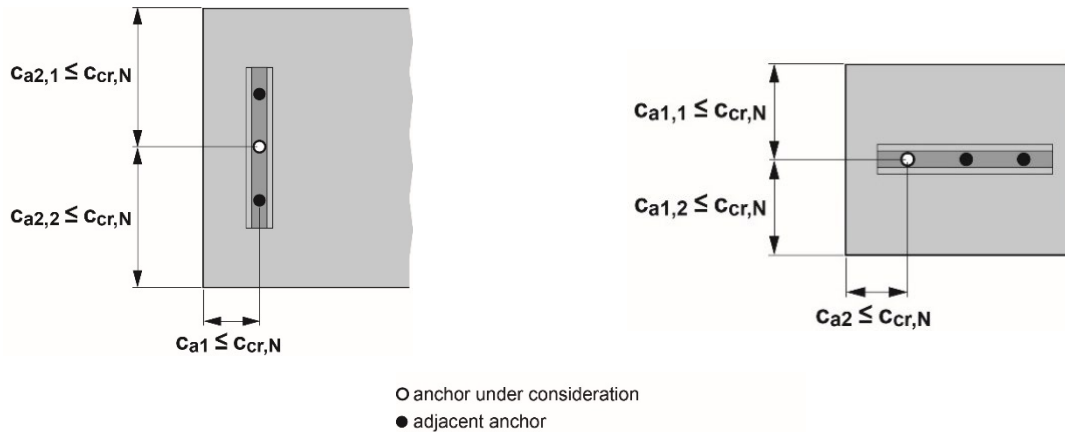

a) anchor channel with influence of one edge and two corners

b) anchor channel with influence of two edges and one corner

Figure 4-7: Examples of anchor channel locations where a reduced value of the embedment depth, $h_{ef,red}$, may be used

The modification factor to account for the influence of location and loading of adjacent anchors, $\psi_{s,N}$, shall be computed in accordance with Eq. (10).

$$\psi_{s,N} = \frac{1}{1 + \sum_{i=2}^{n+1} \left[\left(1 - \frac{s_i}{s_{cr,N}}\right)^{1.5} \cdot \frac{N_{ua,i}^a}{N_{ua,1}^a} \right]} \quad (10)$$

where, as illustrated in [Figure 4-6](#):

s_i = distance between the anchor under consideration and adjacent anchor, in. (mm)

$\leq s_{cr,N}$

$$s_{cr,N} = 2 \left(2.8 - \frac{1.3h_{ef}}{7.1} \right) h_{ef} \geq 3h_{ef}, \text{ in.} \quad (11)$$

$$s_{cr,N} = 2 \left(2.8 - \frac{1.3h_{ef}}{180} \right) h_{ef} \geq 3h_{ef}, \text{ mm}$$

$N_{ua,i}^a$ = factored tension load of an influencing anchor, lb (N)

$N_{ua,1}^a$ = factored tension load of the anchor under consideration, lb (N)

n = number of anchors of all anchor channels within a radial distance $s_{cr,N}$ from the anchor under consideration

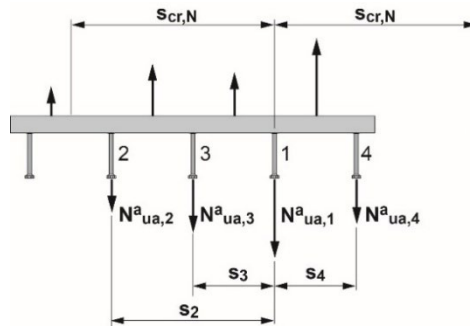

1 = anchor under consideration
 2 to 4 = influencing anchors

Figure 4-8: Example of an anchor channel with non-uniform anchor tension forces

The modification factor for edge effect of anchors loaded in tension, $\psi_{ed,N}$, shall be computed in accordance with Eq. (12) or (13).

If $c_{a1} \geq c_{cr,N}$ then $\psi_{ed,N} = 1.0$ (12)

If $c_{a1} < c_{cr,N}$ then $\psi_{ed,N} = (c_{a1} / c_{cr,N})^{0.5} \leq 1.0$ (13)

where:

$$c_{cr,N} = 0.5s_{cr,N} = \left(2.8 - \frac{1.3h_{ef}}{7.1} \right) h_{ef} \geq 1.5h_{ef}, \text{ in.} \tag{14}$$

$$c_{cr,N} = 0.5s_{cr,N} = \left(2.8 - \frac{1.3h_{ef}}{180} \right) h_{ef} \geq 1.5h_{ef}, \text{ mm}$$

If anchor channels are located in a narrow concrete member with multiple edge distances $c_{a1,1}$ and $c_{a1,2}$ (as shown in [Figure 4-9b](#)), the minimum value of $c_{a1,1}$ and $c_{a1,2}$ shall be inserted in Eq. (13).

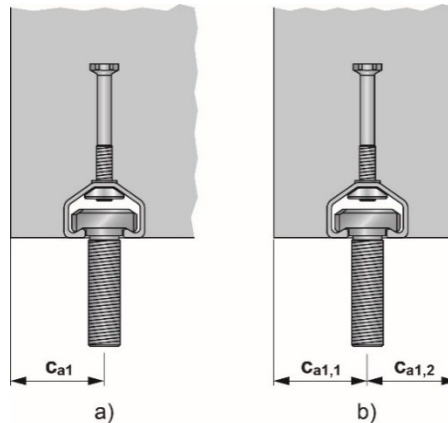

Figure 4-9: Anchor channel

a) at an edge b) in a narrow member

The modification factor for corner effect for anchors loaded in tension, $\psi_{co,N}$, shall be computed in accordance with Eq. (15) or (16).

If $c_{a2} \geq c_{cr,N}$ then $\psi_{co,N} = 1.0$ (15)

If $c_{a2} < c_{cr,N}$ then $\psi_{co,N} = (c_{a2} / c_{cr,N})^{0.5} \leq 1.0$ (16)

where:

c_{a2} = distance of the anchor under consideration to the corner (see [Figure 4-10a, b](#))

If an anchor is influenced by two corners (as illustrated in Figure 4-10c), the factor $\psi_{co,N}$ shall be computed for each of the values $c_{a2,1}$ and $c_{a2,2}$ and the product of the factors, $\psi_{co,N}$, shall be inserted in Eq. (6).

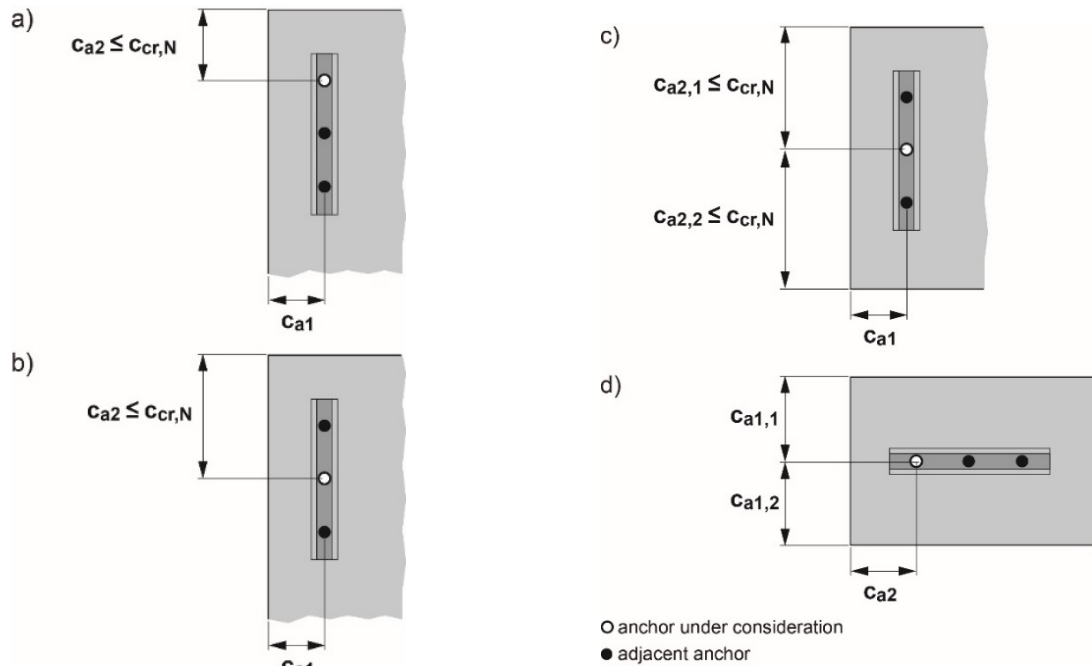

Figure 4-10: Anchor channel at a corner of a concrete member

For anchor channels located in a region of a concrete member where analysis indicates no cracking at service load levels, the following modification factor shall be permitted

$$\psi_{c,N} = 1.25$$

Where analysis indicates cracking at service load levels $\psi_{c,N}$ shall be taken as 1.0. The cracking in the concrete shall be controlled by flexural reinforcement distributed in accordance with ACI 318-19 Section 24.3.2 and 24.3.3, or equivalent crack control shall be provided by confining reinforcement.

The modification factor for anchor channels designed for uncracked concrete without supplementary reinforcement to control splitting, $\psi_{cp,N}$, shall be computed in accordance with Eq. (17) or (18). The critical edge distance, c_{ac} , shall be taken from Table 8-6 of this report.

$$\text{If } c_{a,min} \geq c_{ac} \text{ then } \psi_{cp,N} = 1.0 \quad (17)$$

$$\text{If } c_{a,min} < c_{ac} \text{ then } \psi_{cp,N} = c_{a,min} / c_{ac} \quad (18)$$

whereby $\psi_{cp,N}$ as determined in accordance with Eq. (18) shall not be taken less than $c_{cr,N} / c_{ac}$, with $c_{cr,N}$ taken from Eq. (14).

For all other cases, $\psi_{cp,N}$ shall be taken as 1.0.

Where anchor reinforcement is developed in accordance with ACI 318-19 Chapter 25 on both sides of the breakout surface for an anchor or an anchor channel, the design strength of the anchor reinforcement, ϕN_{ca} , shall be permitted to be used instead of the concrete breakout strength, ϕN_{cb} , in determining ϕN_n . The anchor reinforcement for one anchor shall be designed for the tension force, N_{ua} , on this anchor using a strut-and-tie model. The provisions in Figure 4-11 shall be taken into account when sizing and detailing the anchor reinforcement. Anchor reinforcement shall consist of stirrups made from deformed reinforcing bars with a maximum diameter of $5/8$ in. (No. 5 bar) (16 mm). A strength reduction factor, ϕ , of 0.75 shall be used in the design of the anchor reinforcement. In case of anchor reinforcement, its location shall account for all factors (e.g. concrete cover, bend radius of intersecting reinforcement such as stirrups) as per ACI-318.

For anchor channels located parallel to the edge of a concrete member or in a narrow concrete member, the plane of the anchor reinforcement shall be arranged perpendicular to the longitudinal axis of the channel, as shown in Figure 4-11.

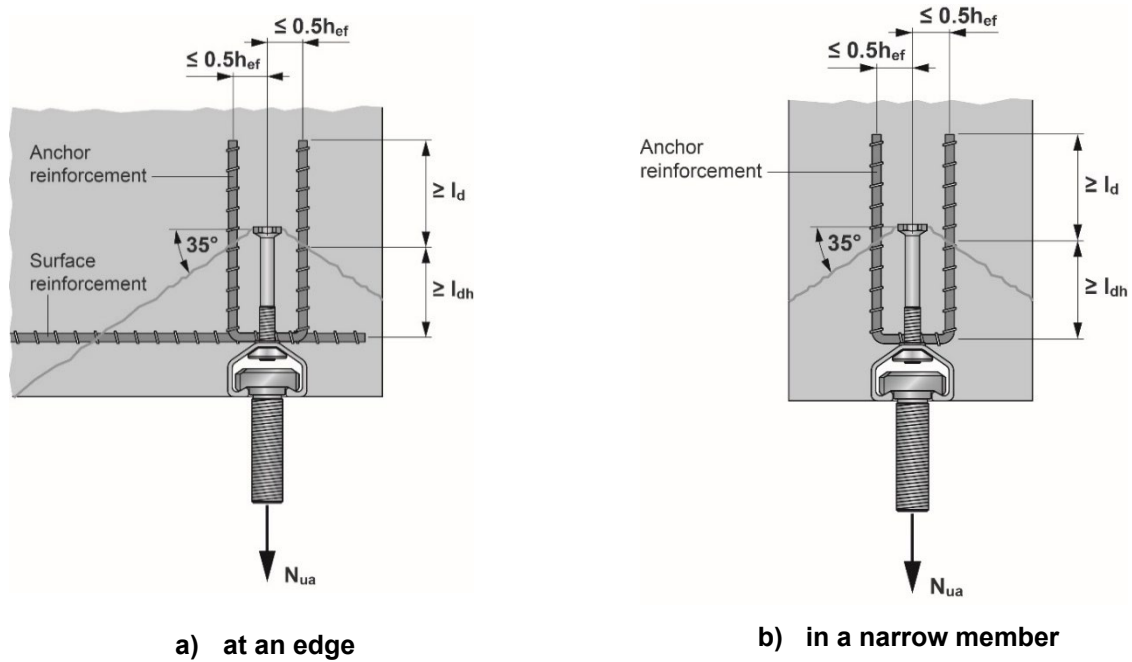

Figure 4-11: Arrangement of anchor reinforcement for anchor channels loaded by tension load

4.1.3.2.4 Pullout Strength in Tension:

For anchors of anchor channels, the pullout strength N_{pn} shall be computed in accordance with Sections 17.6.3.1, 17.6.3.2, and 17.6.3.3 of ACI 318-19.

4.1.3.2.5 Concrete Side-Face Blowout Strength of Anchor Channels in Tension:

For anchor channels with deep embedment close to an edge ($h_{ef} > 2c_{a1}$) the nominal side-face blowout strength, N_{sb} , of a single anchor shall be computed in accordance with Eq. (19).

$$N_{sb} = N_{sb}^0 \cdot \psi_{s,Nb} \cdot \psi_{g,Nb} \cdot \psi_{co,Nb} \cdot \psi_{h,Nb} \cdot \psi_{c,Nb} \cdot lb(N) \quad (19)$$

The basic nominal strength of a single anchor without influence of neighboring anchors, corner or member thickness effects in cracked concrete, N_{sb}^0 , shall be computed in accordance with Eq. (20).

$$N_{sb}^0 = 128 \cdot \lambda \cdot c_{a1} \cdot \sqrt{A_{brg}} \cdot \sqrt{f'_c} \cdot lb \quad (20)$$

$$N_{sb}^0 = 10.5 \cdot \lambda \cdot c_{a1} \cdot \sqrt{A_{brg}} \cdot \sqrt{f'_c} \cdot N$$

The modification factor accounting for the distance to and loading of neighboring anchors, $\psi_{s,Nb}$, shall be computed in accordance with Eq. (10), however $s_{cr,N}$ shall be replaced by $s_{cr,Nb}$, which shall be computed in accordance with Eq. (21).

$$s_{cr,Nb} = 4c_{a1}, \text{ in. (mm)} \quad (21)$$

The modification factor to account for influence of the bearing area of neighboring anchors, $\psi_{g,Nb}$, shall be computed in accordance with Eq. (22) or Eq. (23).

If $s \geq 4c_{a1}$ then $\psi_{g,Nb} = 1.0$ (22)

If $s < 4c_{a1}$ then $\psi_{g,Nb} = \sqrt{n} + (1 - \sqrt{n}) \cdot \frac{s}{4c_{a1}} \geq 1.0$ (23)

where:

n = number of tensioned anchors in a row parallel to the edge. For adjacent anchor channels, s in Equation (23) shall be taken as the maximum of: a) the individual anchor spacing s ; and b) the spacing between end anchors of the adjacent channel end anchors $s_{ch,x}$

The modification factor to account for influence of corner effects, $\psi_{co,Nb}$, shall be computed in accordance with Eq. (24).

$$\psi_{co,Nb} = \left(\frac{c_{a2}}{c_{cr,Nb}} \right)^{0.5} \leq 1.0 \quad (24)$$

where:

c_{a2} = corner distance of the anchor, for which the resistance is computed, in. (mm)

$$c_{cr,Nb} = 2c_{a1}, \text{ in. (mm)} \quad (25)$$

If an anchor is influenced by two corners ($c_{a2} < 2c_{a1}$), then the factor, $\psi_{co,Nb}$, shall be computed for $c_{a2,1}$ and $c_{a2,2}$ and the product of the factors shall be inserted in Eq. (19).

The modification factor to account for influence of the member thickness, $\psi_{h,Nb}$ shall be computed in accordance with Eq. (26) or Eq. (27).

$$\text{If } f > 2c_{a1} \quad \text{then} \quad \psi_{h,Nb} = 1.0 \quad (26)$$

$$\text{If } f \leq 2c_{a1} \quad \text{then} \quad \psi_{h,Nb} = \frac{h_{ef} + f}{4c_{a1}} \leq \frac{2c_{a1} + f}{4c_{a1}} \quad (27)$$

where:

f = distance between the anchor head and the surface of the concrete member opposite to the anchor channel (as illustrated in [Figure 4-12](#)), in. (mm)

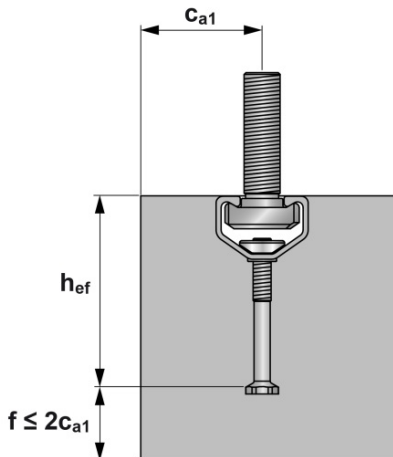

Figure 4-12: Anchor channel at the edge of a thin concrete member

The following modification factor to account for influence of uncracked concrete, $\psi_{c,Nb}$, shall be permitted:

$$\psi_{c,Nb} = 1.25$$

For anchor channels located perpendicular to the edge and loaded uniformly, verification is only required for the anchor closest to the edge.

4.1.3.3 Shear loads acting on the channel system perpendicular to its longitudinal axis:

4.1.3.3.1 Required verifications:

Following verifications are required:

- Steel Failure: Strength of channel bolt, strength for local failure of channel lip, strength of connection between anchor and channel, and strength of anchor, see Section 4.1.3.3.2.
- Concrete edge breakout strength of anchor channel in shear, see Section 4.1.3.3.3.
- Concrete pryout strength of anchor channel in shear, see Section 4.1.3.3.4.

4.1.3.3.2 Steel strength of anchor channel system in shear perpendicular to its longitudinal axis:

For anchor channel systems, the nominal steel shear strength shall be determined as follows:

The nominal strength of a channel bolt in shear, V_{ss} , must be taken from [Table 8-18](#) of this report.

If the fixture is not clamped against the concrete but secured to the channel bolt at a distance from the concrete surface (e.g. by double nuts), the nominal strength of a channel bolt in shear, $V_{ss,M}$, shall be computed in accordance with Eq. (28).

$$V_{ss,M} = \frac{\alpha_M \cdot M_{ss}}{\ell}, \text{ lb (N)} \quad (28)$$

where:

- α_M = factor to take into account the restraint condition of the fixture
- = 1.0 if the fixture can rotate freely (no restraint)
- = 2.0 if the fixture cannot rotate (full restraint)

$$M_{ss} = M_{ss}^0 \left(1 - \frac{N_{ua}}{\phi N_{ss}} \right), \text{ lb-in (N-mm)} \quad (29)$$

M_{ss}^0 = nominal flexural strength of channel bolt according to [Table 8-18](#) of this report.

$$\leq 0.5N_{sl} \cdot a$$

$$\leq 0.5N_{ss} \cdot a$$

ℓ = lever arm, in. (mm)

a = internal lever arm, in. (mm) as illustrated in [Figure 4-13](#)

T_s = tension force acting on channel lips

C_s = compression force acting on channel lips

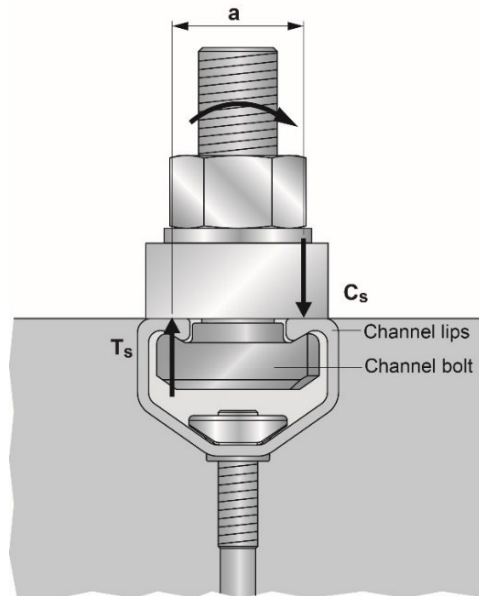

Figure 4-13: Definition of internal lever arm

The nominal strength of the channel lips to take up shear loads perpendicular to the channel transmitted by a channel bolt, $V_{sl,y}$, must be taken from [Tables 8-7](#) and [8-8](#) of this report.

The nominal strength of one anchor, $V_{sa,y}$, to take up shear loads perpendicular to the channel must be taken from [Tables 8-7](#) and [8-8](#) of this report.

The nominal strength of the connection between one anchor and the anchor channel, $V_{sc,y}$, to take up shear loads perpendicular to the channel must be taken from [Tables 8-7](#) and [8-8](#) of this report.

4.1.3.3.3 Concrete breakout strength of an anchor channel in shear perpendicular to its longitudinal axis:

The nominal concrete breakout strength, $V_{cb,y}$, in shear perpendicular to the channel of a single anchor of an anchor channel in cracked concrete shall be computed as follows:

- a) For a shear force perpendicular to the edge by Eq. (30)

$$V_{cb,y} = V_b \cdot \psi_{s,v} \cdot \psi_{co,v} \cdot \psi_{c,v} \cdot \psi_{h,v}, \text{ lb (N)} \quad (30)$$

- b) For a shear force parallel to an edge (as shown in [Figure 4-14](#)), $V_{cb,y}$ shall be permitted to be 2.5 times the value of the shear force determined from Eq. (30) with the shear force assumed to act perpendicular to the edge.

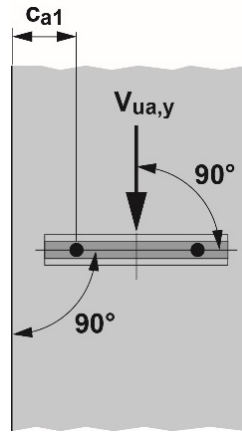

Figure 4-14: Anchor channel arranged perpendicular to the edge and loaded parallel to the edge

The basic concrete breakout strength in shear perpendicular to the channel of a single anchor of an anchor channel in cracked concrete, V_b , shall be computed in accordance with Eq. (31).

$$V_b = \lambda \cdot \alpha_{ch,V} \cdot \sqrt{f'_c} \cdot c_{a1}^{4/3} \cdot lbf(N) \tag{31}$$

where:

$\alpha_{ch,V}$ = shall be taken from [Tables 8-15](#) and [8-16](#) of this report

f'_c = the lesser of the specified concrete compressive strength and 8,500 psi (59 MPa)

The modification factor to account for the influence of location and loading of adjacent anchors, $\psi_{s,V}$ shall be computed in accordance with Eq. (32).

$$\psi_{s,V} = \frac{1}{1 + \sum_{i=2}^{n+1} \left[\left(1 - \frac{s_i}{s_{cr,V}} \right)^{1.5} \cdot \frac{V_{ua,i}^a}{V_{ua,1}^a} \right]} \tag{32}$$

where, as illustrated in [Figure 4-15](#):

s_i = distance between the anchor under consideration and the adjacent anchors

$$\leq s_{cr,V}$$

$$s_{cr,V} = 4c_{a1} + 2b_{ch}, \text{ in. (mm)} \tag{33}$$

$V_{ua,i}^a$ = factored shear load of an influencing anchor, lb (N)

$V_{ua,1}^a$ = factored shear load of the anchor under consideration, lb (N)

n = number of anchors of all anchor channels within a radial distance $s_{cr,V}$ from the anchor under consideration

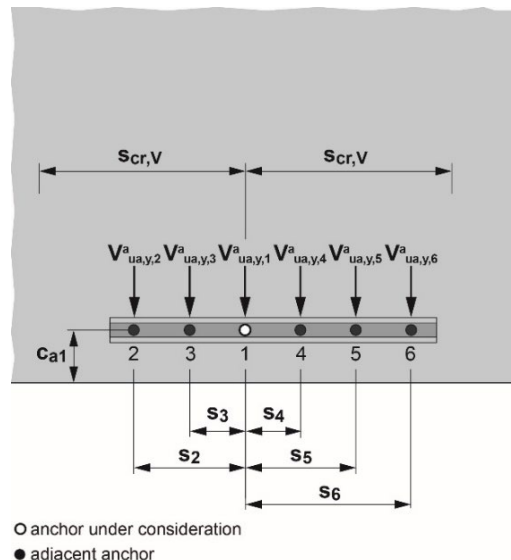

Figure 4-15: Example of an anchor channel with different anchor shear forces

The modification factor for corner effect for an anchor loaded in shear perpendicular to the channel, $\psi_{co,V}$, shall be computed in accordance with Eq. (34) or (35).

If $c_{a2} \geq c_{cr,V}$ then $\psi_{co,V} = 1.0$ (34)

If $c_{a2} < c_{cr,V}$ then $\psi_{co,V} = (c_{a2} / c_{cr,V})^{0.5}$ (35)

where:

$c_{cr,V} = 2c_{a1} + b_{ch}$, in. (mm) (36)

If an anchor is influenced by two corners (as shown in Figure 4-16b), then the factor $\psi_{co,V}$ shall be computed for each corner in accordance with Eq. (34) or (35) and the product of the values of $\psi_{co,V}$ shall be inserted in Eq. (30).

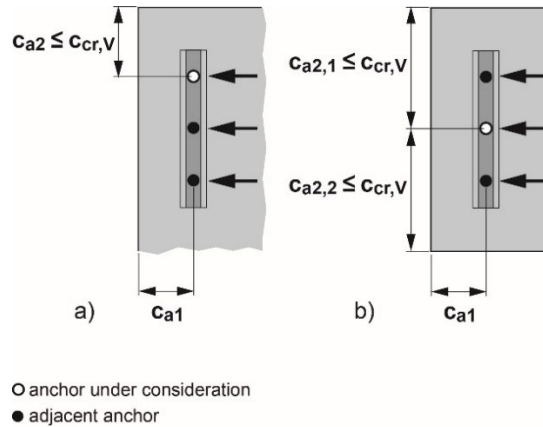

Figure 4-16: Example of an anchor channel loaded in shear with anchors
a) influenced by one corner
b) influenced by two corners

For anchor channels located in a region of a concrete member where analysis indicates no cracking at service load levels, the following modification factor shall be permitted:

$\psi_{c,V} = 1.4$

For anchor channels located in a region of a concrete member where analysis indicates cracking at service load levels, the following modifications shall be permitted:

$\psi_{c,V} = 1.0$ for anchor channels in cracked concrete with no supplementary reinforcement

$\psi_{c,V} = 1.2$ for anchor channels in cracked concrete with edge reinforcement of a No. 4 bar (12.7 mm) or greater between the anchor channel and the edge in accordance with Figure 4-17. Anchor reinforcement location shall account for all factors (e.g. concrete cover, bend radius of intersecting reinforcement such as stirrups) as per ACI-318

$\psi_{c,V} = 1.4$ for anchor channels in cracked concrete containing edge reinforcement with a diameter of 1/2 inch (12.7 mm) or greater (No. 4 bar or greater) between the anchor channel and the edge, and with the edge reinforcement enclosed within stirrups with a diameter of 1/2 inch (12.7 mm) or greater (No. 4 or greater) spaced 8 inches (200 mm) maximum

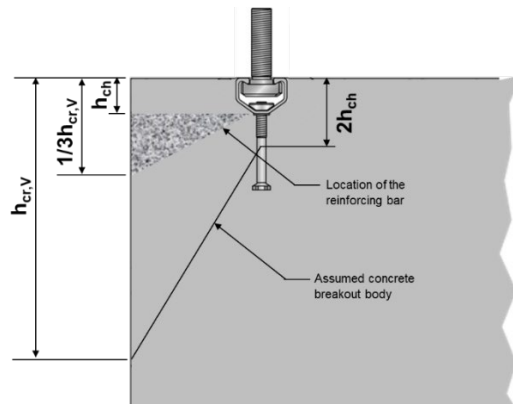

Figure 4-17: Recommended area for the location of the edge reinforcement rebar

The modification factor for anchor channels located in a concrete member with $h < h_{cr,V}$, $\psi_{h,V}$ (an example is given in [Figure 4-18](#)), shall be computed in accordance with Eq. (37).

$$\psi_{h,V} = \left(\frac{h}{h_{cr,V}} \right)^{0.5} \leq 1.0 \quad (37)$$

where:

$$h_{cr,V} = 2c_{a1} + 2h_{ch}, \text{ in. (mm)} \quad (38)$$

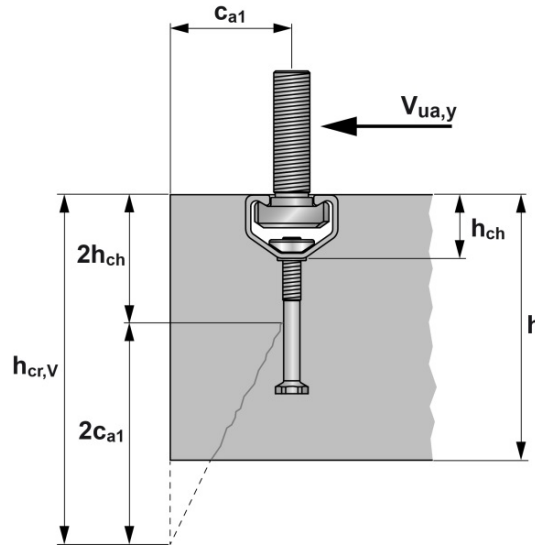
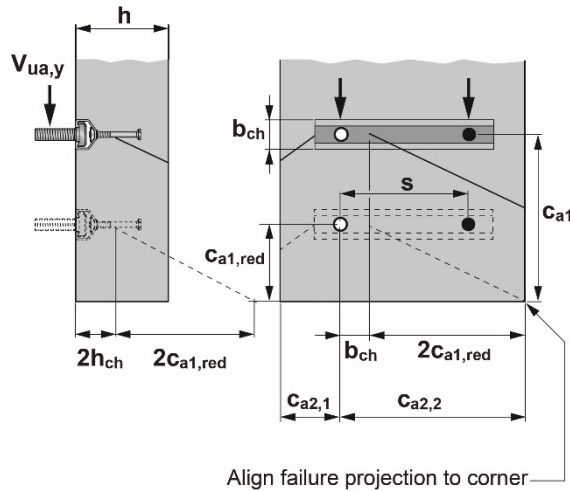

Figure 4-18: Example of an anchor channel in a member with a thickness $h < h_{cr,V}$

Where an anchor channel is located in a narrow member ($c_{a2,max} < c_{cr,V}$) with a thickness $h < h_{cr,V}$ (see [Figure 4-19](#)), the edge distance c_{a1} in Eq. (31), (33), (36) and (38) shall not exceed the value $c_{a1,red}$ determined in accordance with Eq. (39).

$$c_{a1,red} = \max \left[\frac{c_{a2,max} - b_{ch}}{2}, \frac{h - 2h_{ch}}{2} \right], \text{ in. (mm)} \quad (39)$$

where $c_{a2,max}$ is the largest of the edge distances perpendicular to the longitudinal axis of the channel.



For this example, the value of $c_{a1,red}$ is obtained by moving the failure surface forward until it intersects the corner as shown.

Figure 4-19: Example of an anchor channel influenced by two corners and member thickness (in this example $c_{a2,2}$ is decisive for the determination of $c_{a1,red}$)

For anchor channels with b_{ch} greater than 1.1 inches (28 mm) and h_{ch} greater than 0.6 inches (15 mm) arranged parallel to the edge and loaded by a shear load perpendicular to the edge and anchor reinforcement developed in accordance with ACI 318-19 Chapter 25 on both sides of the concrete surface, the design strength of the anchor reinforcement, $\phi V_{ca,y}$, shall be permitted to be used instead of the concrete breakout strength, $\phi V_{cb,y}$, in determining $\phi V_{n,y}$.

A strength reduction factor, ϕ , of 0.75 shall be used in the design of the anchor reinforcement. The strength of the anchor reinforcement assumed in design shall not exceed the value in accordance with Eq. (40). Only anchor reinforcement that complies with Figure 4-20 shall be assumed as effective.

The maximum strength of the anchor reinforcement, $V_{ca,y,max}$, of a single anchor of an anchor channel shall be computed in accordance with Eq. (40).

$$V_{ca,y,max} = \frac{2.85}{c_{a1}^{0.12}} \cdot V_{cb,y}, lb \tag{40}$$

$$V_{ca,y,max} = \frac{4.2}{c_{a1}^{0.12}} \cdot V_{cb,y}, N$$

where $V_{cb,y}$ is determined in accordance with Eq. (30).

Anchor reinforcement shall consist of stirrups made from deformed reinforcing steel bars with a maximum diameter of $5/8$ in. (15.9 mm) (No. 5 bar) and straight edge reinforcement with a diameter not smaller than the diameter of the stirrups (as shown in Figure 4-20). Only one bar at both sides of each anchor shall be assumed as effective. The distance of this bar from the anchor shall not exceed $0.5 c_{a1}$ and the anchorage length in the breakout body shall be not less than 4 times the bar diameter. The distance between stirrups shall not exceed the smaller of anchor spacing or 6 inches (152 mm).

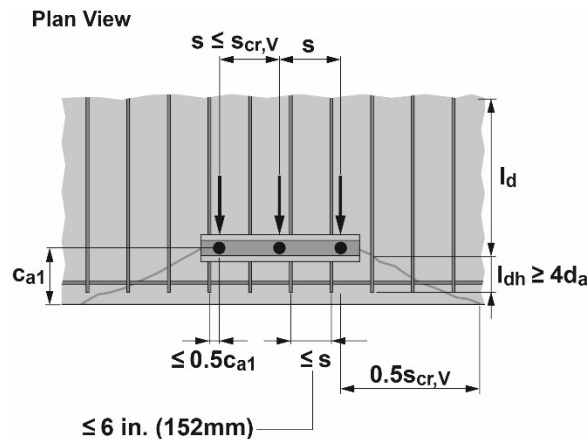

Figure 4-20: Requirements for detailing of anchor reinforcement of anchor channels

The anchor reinforcement of an anchor channel shall be designed for the highest anchor load, $V_{ua,y}^a$, of all anchors but at least for the highest individual shear load, $V_{ua,y}^b$, acting on the channel. This anchor reinforcement shall be arranged at all anchors of an anchor channel. In case of anchor reinforcement, its location shall account for all factors (e.g. concrete cover, bend radius of intersecting reinforcement such as stirrups) as per ACI-318.

For anchor channels in a parallel configuration, it shall be permitted to calculate the concrete breakout strength either for the anchor channel closest to the edge or the anchor channel furthest from the edge.

The nominal concrete breakout strength shall be computed as follows:

- a) For verification of the anchor channel closest to the edge, the nominal concrete breakout strength shall be calculated according to Equation (41).

$$V_{cb} = \min(n_{ch} \cdot V_{cb}(c_{a1,1}); V_{cb}(c_{a1,n1})), lb (N) \tag{41}$$

- b) For verification of the anchor channel furthest from the edge, the nominal concrete breakout strength shall be calculated according to Equation (42).

$$V_{cb} = V_{cb}(c_{a1,n1}), lb (N) \tag{42}$$

For case b) the anchor channels closer to the edge shall be assumed to carry zero tension and shear load.

4.1.3.3.4 Concrete pryout strength of anchor channels in shear perpendicular to the channel axis:

The nominal pryout strength, $V_{cp,y}$, in shear of a single anchor of an anchor channel without anchor reinforcement shall be computed in accordance with Eq. (43).

$$V_{cp} = V_{cp,x} = V_{cp,y} = k_{cp} \cdot N_{cb}, \quad lb (N) \quad (43)$$

where:

k_{cp} = shall be taken from [Tables 8-15](#) and [8-16](#)

N_{cb} = nominal concrete breakout strength of the anchor under consideration, lb (N), determined in accordance with Section 4.1.3.2.3; however in the determination of the modification factor $\psi_{s,N}$, the values $N_{ua,1}^a$ and $N_{ua,i}^a$ in Eq. (10) shall be replaced by $V_{ua,1}^a$ and $V_{ua,i}^a$, respectively.

The nominal pryout strength, $V_{cp,y}$, in shear of a single anchor of an anchor channel with anchor reinforcement shall not exceed:

$$V_{cp} = V_{cp,x} = V_{cp,y} = 0.75 \cdot k_{cp} \cdot N_{cb}, \quad lb (N) \quad (44)$$

with k_{cp} and N_{cb} as defined above.

4.1.3.4 Shear loads acting on the channel system in direction of the longitudinal channel axis:**4.1.3.4.1 Required verifications:**

Following verifications are required:

- a) Steel Failure: Strength of channel bolt, strength of connection between channel lips and channel bolt, strength of connection between anchor and channel, and strength of anchor, see Section 4.1.3.4.2.
- b) Concrete edge breakout strength of anchor channel in shear, see Section 4.1.3.4.3.
- c) Concrete pryout strength of anchor channel in shear, see Section 4.1.3.4.4.

4.1.3.4.2 Steel strength of anchor channel systems in shear in the direction of the longitudinal channel axis:

The nominal strength of a channel bolt in shear, V_{ss} , must be taken from [Table 8-18](#) of this report.

If the fixture is not clamped against the concrete but secured to the channel bolt at a distance from the concrete surface (e.g. by double nuts), the nominal strength of a channel bolt in shear, $V_{ss,M}$, shall be computed in accordance with Eq. (28).

The nominal strength of the connection between channel lips and channel bolt to take up shear loads acting in longitudinal channel axis, $V_{sl,x}$, must be taken from [Table 8-9](#), [Table 8-10](#), [Table 8-11](#), [Table 8-12](#), [Table 8-13](#) or [Table 8-14](#), as applicable.

The nominal strength of one anchor, $V_{sa,x}$, to take up shear loads acting in longitudinal channel axis must be taken from [Tables 8-7](#) and [8-8](#).

The nominal strength of the connection between one anchor and the anchor channel, $V_{sc,x}$, to take up shear loads acting in longitudinal channel axis must be taken from [Tables 8-7](#) and [8-8](#).

4.1.3.4.3 Concrete breakout strength of anchor channels in shear in the direction of the longitudinal channel axis:

The nominal concrete breakout strength, $V_{cb,x}$, in shear acting in longitudinal direction of an anchor channel in cracked concrete shall be computed as follows:

- a) For a shear force perpendicular to the edge, by Section 17.7.2.1 of ACI 318-19. The basic concrete breakout strength in shear in longitudinal channel axis of a single round anchor in an anchor channel in cracked concrete, V_b , shall be computed in accordance with Section 17.7.2.2 of ACI 318-19.
- b) For a shear force parallel to an edge, $V_{cb,x}$ shall be permitted to be twice the value of the shear force determined from Section 17.7.2.1 of ACI 318-19 with the shear force assumed to act perpendicular to the edge.

4.1.3.4.4 Concrete pryout strength for anchor channels in shear in the direction of the longitudinal channel axis:

The nominal pryout strength, $V_{cp,x}$, in shear of a single anchor of an anchor channel without anchor reinforcement shall be computed in accordance with Eq. (43).

The nominal pryout strength, $V_{cp,x}$, in shear of a single anchor of an anchor channel with anchor reinforcement shall not exceed Eq. (44).

4.1.3.5 Requirements for Seismic design:

The design of anchor channel systems to resist tension loads in SDC C, D, E or F where Section 17.10.5.2 of ACI 318-19 applies shall satisfy the requirements of Section 17.10.5.3 (b), (c), or (d) of ACI 318-19.

The design of anchor channel systems to resist shear loads in SDC C, D, E or F where Section 17.10.6.2 of ACI 318-19 applies shall satisfy the requirements of Section 17.10.6.3 of ACI 318-19.

Anchor channel systems shall be designed according to ACI 318-19 Section 17.10.6.3.

For anchor channel systems in SDC C, D, E or F the design strengths given in Section 4.1.3.1 through Section 4.1.3.4 shall be taken as the corresponding seismic design strengths $\phi N_{n,seis}$, $\phi V_{n,x,seis}$ and $\phi V_{n,y,seis}$.

4.1.3.6 Interaction of tensile and shear forces:

If forces act in more than one direction the combination of loads has to be verified.

Anchor channel systems subjected to combined axial and shear loads shall be designed to satisfy the following requirements by distinguishing between steel failure of the channel bolt, steel failure modes of the channel and concrete failure modes.

4.1.3.6.1 Steel failure of channel bolts under combined loads:

For channel bolts, Eq. (45) shall be satisfied.

$$\left(\frac{N_{ua}^b}{\phi N_{ss}} \right)^2 + \left(\frac{V_{ua}^b}{\phi V_{ss}} \right)^2 \leq 1.0 \quad (45)$$

where:

$$V_{ua}^b = \left[(V_{ua,y}^b)^2 + (V_{ua,x}^b)^2 \right]^{0.5}$$

This verification is not required in case of shear load with lever arm as Eq. (28) accounts for the interaction.

4.1.3.6.2 Steel failure modes of anchor channel systems under combined loads:

For steel failure modes of anchor channel systems Eq. (46), Eq. (47) and Eq. (48) shall be satisfied.

a) For anchor and connection between anchor and channel:

$$\begin{aligned} & \max \left(\frac{N_{ua}^a}{\phi N_{sa}}, \frac{N_{ua}^a}{\phi N_{sc}} \right)^\alpha + \max \left(\frac{V_{ua,y}^a}{\phi V_{sa,y}}, \frac{V_{ua,y}^a}{\phi V_{sc,y}} \right)^\alpha \\ & + \max \left(\frac{V_{ua,x}^a}{\phi V_{sa,x}}, \frac{V_{ua,x}^a}{\phi V_{sc,x}} \right)^2 \leq 1.0 \end{aligned} \quad (46)$$

where:

$\alpha = 2$ for anchor channels with $\max(V_{sa,y}; V_{sc,y}) \leq \min(N_{sa}; N_{sc})$

$\alpha = 1$ for anchor channels with $\max(V_{sa,y}; V_{sc,y}) > \min(N_{sa}; N_{sc})$

It shall be permitted to assume reduced values for $V_{sa,y}$ and $V_{sc,y}$ corresponding to the use of an exponent $\alpha = 2$. In this case the reduced values for $V_{sa,y}$ and $V_{sc,y}$ shall also be used in Section 4.1.3.3.1a).

b) At the point of load application:

$$\left(\frac{N_{ua}^b}{\phi N_{sl}} \right)^\alpha + \left(\frac{V_{ua,y}^b}{\phi V_{sl,y}} \right)^\alpha + \left(\frac{V_{ua,x}^b}{\phi V_{sl,x}} \right)^2 \leq 1.0 \quad (47)$$

$$\left(\frac{M_{u,flex}}{\phi M_{s,flex}} \right)^\alpha + \left(\frac{V_{ua,y}^b}{\phi V_{sl,y}} \right)^\alpha + \left(\frac{V_{ua,x}^b}{\phi V_{sl,x}} \right)^2 \leq 1.0 \quad (48)$$

where:

$\alpha = 2$ for anchor channels with $V_{sl,y} \leq N_{sl}$

$\alpha = 1$ for anchor channels with $V_{sl,y} > N_{sl}$

It shall be permitted to assume reduced values for $V_{sl,y}$ corresponding to the use of an exponent $\alpha = 2$. In this case the reduced value for $V_{sl,y}$ shall also be used in Section 4.1.3.3.1a).

4.1.3.6.3 Concrete failure modes of anchor channel systems under combined loads:

For concrete failure modes, anchor channels shall be designed to satisfy the requirements given in a) through d).

$$a) \text{ If } \left(\frac{V_{ua,y}^a}{\phi V_{nc,y}} \right) + \left(\frac{V_{ua,x}^a}{\phi V_{nc,x}} \right) \leq 0.2$$

then the full strength in tension shall be permitted: $\phi N_{nc} \geq N_{ua}^a$

$$b) \text{ If } N_{ua}^a \leq 0.2\phi N_{nc} \text{ then the full strength in shear shall be permitted: } \left(\frac{V_{ua,y}^a}{\phi V_{nc,y}} \right) + \left(\frac{V_{ua,x}^a}{\phi V_{nc,x}} \right) \leq 1.0$$

$$c) \text{ If } \left(\frac{V_{ua,y}^a}{\phi V_{nc,y}} \right) + \left(\frac{V_{ua,x}^a}{\phi V_{nc,x}} \right) > 0.2 \text{ and } N_{ua}^a > 0.2\phi N_{nc}$$

then Eq. (49) applies

$$\left(\frac{N_{ua}^a}{\phi N_{nc}} \right) + \left(\frac{V_{ua,y}^a}{\phi V_{nc,y}} \right) + \left(\frac{V_{ua,x}^a}{\phi V_{nc,x}} \right) \leq 1.2 \quad (49)$$

d) Alternatively, instead of satisfying the requirements in a) through c), the interaction Eq. (50) shall be satisfied:

$$\left(\frac{N_{ua}^a}{\phi N_{nc}} \right)^{5/3} + \left(\frac{V_{ua,y}^a}{\phi V_{nc,y}} \right)^{5/3} + \left(\frac{V_{ua,x}^a}{\phi V_{nc,x}} \right)^{5/3} \leq 1.0 \quad (50)$$

Where anchors consist of deformed reinforcing bars in accordance with Section 3.1, and the deformed reinforcing bars are lap spliced with reinforcing bars in the member according to the requirements of ACI 318-19 Section 25.5 the interaction Eq. (51) shall be satisfied.

$$\left(\frac{V_{ua,y}^a}{\phi V_{nc,y}} \right)^{5/3} + \left(\frac{V_{ua,x}^a}{\phi V_{nc,x}} \right)^{5/3} \leq \alpha \quad (51)$$

where

$\alpha = 0.9$ for anchor channels with deformed reinforcing bars not debonded

$\alpha = 1.0$ for anchor channels with deformed reinforcing bars debonded underneath the channel profile for a length of 2 in. (50mm)

4.1.4 Minimum Member Thickness, Anchor Spacing, and Edge Distance:

Anchor channels shall satisfy the requirements for edge distance, spacing, and member thickness.

The minimum edge distance, minimum and maximum anchor spacing and minimum member thickness shall be taken from [Tables 8-1](#) and [8-2](#) of this report. The critical edge distance, c_{ac} , shall be taken from [Table 8-6](#) of this report.

4.1.5 Requirements for lightweight concrete:

For the use of anchor channels in lightweight concrete, the modification factor λ shall be taken as 0.75 for all-lightweight concrete and 0.85 for sand-lightweight concrete. Linear interpolation shall be permitted if partial sand replacement is used.

4.2 Allowable Stress Design:

4.2.1 General:

Strength design values determined in accordance with ACI 318-19 Chapter 17, with amendments in Section 4.1 of this report may be converted to values suitable for use with allowable stress design (ASD) load combinations. Such guidance of conversions shall be in accordance with the following:

For anchor channel systems designed using load combinations in accordance with Section 1605.1 of the 2024 IBC, allowable loads shall be established using Eq. (52), Eq. (53), Eq. (54) and Eq. (55).

$$T_{allowable,ASD} = \frac{\phi N_n}{\alpha_{ASD}} \quad (52)$$

$$V_{x,allowable,ASD} = \frac{\phi V_{n,x}}{\alpha_{ASD}} \quad (53)$$

$$V_{y,allowable,ASD} = \frac{\phi V_{n,y}}{\alpha_{ASD}} \quad (54)$$

$$M_{s,flex,allowable,ASD} = \frac{\phi M_{s,flex}}{\alpha_{ASD}} \quad (55)$$

where:

$T_{allowable,ASD}$ = allowable tension load (lb or kN)

$V_{x,allowable,ASD}$ = allowable shear load in longitudinal channel axis, lb (N)

$V_{y,allowable,ASD}$ = allowable shear load perpendicular to the channel axis, lb (N)

$M_{s,flex,allowable,ASD}$ = allowable bending moment due to tension loads lb-in (Nm)

ϕN_n = lowest design strength of an anchor, channel bolt, or anchor channel in tension for controlling failure mode as determined in accordance with ACI 318-19 Chapter 17 with amendments in Section 4.1 of this report, lb (N)

$\phi V_{n,x}$ = lowest design strength of an anchor, channel bolt, or anchor channel in shear in the longitudinal channel axis for controlling failure mode as determined in accordance with ACI 318-19 Chapter 17 with amendments in Section 4.1 of this report, lb (N)

$\phi V_{n,y}$ = lowest design strength of an anchor, channel bolt, or anchor channel in shear perpendicular to the channel axis for controlling failure mode as determined in accordance with ACI 318-19 Chapter 17 with amendments in Section 4.1 of this report, lb (N)

α_{ASD} = conversion factor calculated as a weighted average of the load factors for the controlling load combination. In addition, α_{ASD} shall include all applicable factors to account for non-ductile failure modes and required overstrength

4.2.2 Interaction of tensile and shear forces:

Interaction shall be calculated in accordance with Section 4.1.3.6 and amendments in Section 4.1 of this report.

N_{ua} , $V_{ua,x}$, $V_{ua,y}$ and $M_{u,flex}$ shall be replaced by the unfactored loads T^a , V_x^a , V_y^a and M^a . The design strengths ϕN_n , $\phi V_{n,x}$, $\phi V_{n,y}$ and $\phi M_{s,flex}$ shall be replaced by the allowable loads $T_{allowable,ASD}$, $V_{x,allowable,ASD}$, $V_{y,allowable,ASD}$ and $M_{s,flex,allowable,ASD}$.

where:

T^a = unfactored tension load applied to an anchor channel system, lb (N)

M^a = unfactored bending moment on anchor channel due to tension loads (calculation according to Section 4.1.2.2, lb-in (Nm))

V_x^a = unfactored shear load applied to an anchor channel system in the longitudinal channel axis, lb (N)

V_y^a = unfactored shear load applied to an anchor channel system perpendicular to the channel axis, lb (N)

4.3 Installation:

Installation parameters are provided in [Tables 8-1](#), [8-2](#) and [8-3](#) of this report. Anchor channel location must comply with this report and the plans and specifications approved by the code official. Installation of the anchor channel must conform to the manufacturer's printed installation instructions (MPII) included with the product, as provided in [Figures 8-6](#) and [8-7](#). Installation of the channel bolts must conform to the manufacturer's printed installation instructions (MPII) included with the product, as provided in [Figure 8-8](#), [Figure 8-9](#), [Figure 8-10](#) and [Figure 8-11](#) where no Hilti HIT-HY 100 adhesive is used, [Figure 8-12](#) for anchor channels used in conjunction with Hilti HIT-HY 100 adhesive and [Figures 8-8](#) through [8-11](#) for installation with an appropriate impact wrench in combination with the appropriate adaptive torque module. If there are multiple torques listed in [Table 8-3](#) and [Figures 8-8](#) through [8-11](#), the impact wrench with adaptive torque module applies the minimum torque value listed.

Channel installation in formwork includes the following steps according to [Figures 8-6](#) and [8-7](#):

- (1) Selection of anchor channel in accordance with the design specification.
- (2) Minimum end distance for cutting anchor channels according to [Tables 8-1](#) and [8-2](#).
- (3) Position the anchor channel such that the channel lips will be flush with the surface of the concrete. Secure anchor channels to formwork (3a) or adjoining reinforcing steel (3b) with nails, staples, rivets, or wire ties as appropriate. Supports and attachments shall be adequate to ensure that anchor channels remain in position during concrete placement. Anchor channels shall not be pushed into fresh concrete (3c). Anchors shall not be bent, cut or otherwise modified (3d).
- (4) Anchor channels shall be protected from intrusion of concrete and slurry into the channel during concrete placement. Place and consolidate concrete around anchor channels to mitigate voids. Make sure that channels are leveled.
- (5) Installed anchor channels must be flush with the concrete surface.
- (6, 7) Remove the foam filler after hardening of concrete and striking the formwork.

Channel bolt installation in the anchor channel shall include the following steps according to [Figure 8-8](#), [Figure 8-9](#), [Figure 8-10](#) or [Figure 8-11](#) as applicable:

- (1) Select Hilti channel bolt in accordance with the design specification.
- (2) Place the channel bolt in the channel and lock the channel bolt in the channel by turning it 90 degrees.
- (3) Verify alignment of the bolt with the groove.
- (4) Verify that the channel bolt is not located outside of that portion of the channel bounded by the outermost anchors.
- (5) Channel bolts shall not be cut or otherwise modified.
- (6) Install the fixture distinguishing between installation type A and installation type B.
 - for installation type A the fixture is in contact with the concrete surface and the channel profile (6A).
 - for installation type B suitable steel element e.g. square plate washer is used to avoid introducing forces into the concrete during application of the installation torque T_{inst} . The steel element shall have a sufficient stiffness to avoid deformation of the channel lips (6B).
- (7) Apply the installation torque T_{inst} to the channel bolt with a calibrated torque wrench. Alternatively, specific channel bolts are identified in [Table 8-3](#) which can be installed with the appropriate impact wrench in combination with the appropriate adaptive torque module. Where installation is conducted with a torque wrench, do not exceed the value T_{inst} distinguishing between installation type A and installation type B. Complete removal and reinstallation of the channel bolt HBC-C-N is not allowed.

Where anchor channels are used with Hilti HIT-HY 100 adhesive the following additional installation procedures shall be followed according to [Figure 8-12](#):

- (1) Safety precautions: read instructions, wear goggles, gloves, and other required personal protective equipment. Use of Hilti HIT-HY 100 adhesive is allowed for channels installed top-of-slab or horizontally face-of-slab only. Overhead installation is not permitted.
- (2) Select Hilti channel bolt in accordance with the design specification. Use only HBC-C M16 8.8F, HBC-C M16 8.8G, HBC-C M20 8.8F or HBC-C M20 8.8G in combination with HAC-(V)(-T) 50F, HAC-(V) 60F or HAC-(V)(-T) 70F.
- (3) Place the channel bolt in the channel and lock the channel bolt in the channel by turning it 90 degrees.
- (4) Verify alignment of the bolt with the groove.
- (5) Verify that the distance of channel bolt to outermost anchor is $2\frac{3}{4}$ inches (70 mm) or greater, and that the maximum spacing between bolts is 7 inches (178 mm).
- (6) Verify that the dimension of the attached component along the length of the channel does not exceed $9\frac{1}{4}$ inches (235 mm).
- (7) Apply the installation torque T_{inst} to the channel bolt with a calibrated torque wrench. Alternatively, specific channel bolts are identified in [Table 8-3](#) which can be installed with the appropriate impact wrench in combination with the appropriate adaptive torque module. Where installation is conducted with a torque wrench, Do not exceed the value T_{inst} distinguishing between installation type A and installation type B.

- (8) Following placement and torquing of all channel bolts, inject Hilti HIT-HY 100 adhesive into the channel cavity.
- (9) Observe excess Hilti HIT-HY 100 adhesive on the other side of the fixture.
- (10) When excess Hilti HIT-HY 100 adhesive flows out on the other side of the fixture start filling the anchor channel with Hilti HIT-HY 100 adhesive from the other side.
- (11) Make sure the channel is fully filled with Hilti HIT-HY 100 adhesive.
- (12) Observe curing time according to instructions for use of Hilti HIT-HY 100 adhesive.
- (13) Do not apply longitudinal shear loads to the anchor channel until the cure time for Hilti HIT-HY 100 adhesive has elapsed.

4.4 Special Inspection:

Installations may be made under periodic special inspection or continuous special inspection as determined by the registered design professional. Under the IBC, additional requirements as set forth in Section 1705.1.1 and Table 1705.3 of the 2024 IBC and in accordance with this report must be observed, where applicable.

4.4.1 Inspection requirements:

Prior to concrete placement, the special inspector shall inspect the placement of anchor channels in the formwork to verify anchor channel type, channel size, anchor type, number of anchors, anchor size and, length of anchors, as well as anchor channel location, position, orientation, and edge distance in accordance with the construction documents. The special inspector shall also verify that anchor channels are secured within the formwork in accordance with the manufacturer's printed installation instructions (MPII).

Following placement of concrete and form removal, the special inspector shall verify that the concrete around the anchor channel is without significant visual defects, that the anchor channel is flush with the concrete surface, and that the channel interior is free of concrete, laitance, or other obstructions. When anchor channels are not flush with the concrete surface, the special inspector shall verify that appropriate sized shims are provided in accordance with the MPII in the evaluation report. Following the installation of attachments to the anchor channel, the special inspector shall verify that the specified system hardware, such as T-headed channel bolts and washers, have been used and positioned correctly, and the installation torque has been applied to the channel bolts, in accordance with the installation instructions (MPII).

The special inspector shall be present for the installations of attachments to each type and size of anchor channel. The special inspector shall be present for the filling of the anchor channel with Hilti HIT-HY 100 adhesive, where applicable.

Where they exceed the requirements stated here, the special inspector shall adhere to the special inspection requirements provided in the statement of special inspections as prepared by the registered design professional in responsible charge.

4.4.2 Proof loading program:

Where required by the registered design professional in responsible charge, a program for on-site proof loading (proof loading program) to be conducted as part of the special inspection shall include at a minimum the following information:

1. Frequency and location of proof loading based on channel size and length;
2. Proof loads specified by channel size;
3. Acceptable displacements at proof load;
4. Remedial action in the event of failure to achieve proof load or excessive displacement.

5.0 CONDITIONS OF USE:

The Hilti anchor channel systems described in this report: Hilti anchor channels (HAC(-V) and HAC(-V)-T) and Hilti channel bolts (HBC-B, HBC-C, HBC-T and HBC-C-N) are a suitable alternative to what is specified in, those codes listed in Section 1.0 of this report, subject to the following conditions:

The anchor channel systems, including anchor channels, channel bolts and Hilti HIT-HY 100 must be installed in accordance with the manufacturer's printed installation instructions (MPII) and this report as depicted in [Figure 8-6](#) through [Figure 8-12](#). In case of a conflict, this report governs.

- 5.1** The Hilti serrated anchor channels (HAC-(V)-(T) 30F) with serrated Hilti channel bolts (HBC-B M10 4.6F, HBC-B M10 4.6G and HBC-B M12 4.6G) and the Hilti anchor channels (HAC-V 35F, HAC-(V) 40F, HAC-(V) 50F, HAC-V 50 Rebar XTS, HAC-(V) 60F, HAC-(V) 70F, HAC-V 70 Rebar XTS) with Hilti channel bolts (HBC-C M12 8.8F, HBC-C M12 8.8G, HBC-C M16 4.6F, HBC-C M16 50R, HBC-C M16 8.8F, HBC-C M16 8.8G, HBC-C M20 8.8F, HBC-C M20 8.8G) are used to resist static, wind, and seismic (IBC Seismic Design Categories A and B) tension loads (N_{ua}) and shear loads perpendicular to the longitudinal channel axis ($V_{ua,y}$) or any combination of these loads applied at any location between the outermost anchors of the anchor channel in accordance with Figure 2-1 of this report.

The Hilti serrated anchor channels (HAC-(V)-(T) 30F) with serrated Hilti channel bolts (HBC-B M12 4.6F) and Hilti anchor channels (HAC-V 35F, HAC-(V) 40F, HAC-(V) 50F, HAC-V 50 Rebar XTS, HAC-(V) 60F, HAC-(V) 70F, HAC-V 70 Rebar XTS) with locking Hilti channel bolts (HBC-C-N M12 8.8F, HBC-C-N M16 8.8F and HBC-C-N M20 8.8F) and Hilti serrated anchor channels (HAC-(V)-T 50F, HAC-V-T 50 Rebar XTS, HAC-(V)-T 70F, HAC-V(-T) 70 Rebar XTS) with serrated Hilti channel bolts (HBC-T M12 8.8F, HBC-T M16 8.8F, HBC-T M20 8.8F) are used to resist static, wind, and seismic (IBC Seismic Design Categories A through F) tension loads (N_{ua}) and shear loads perpendicular to the longitudinal channel axis ($V_{ua,y}$), shear loads acting in the direction of the longitudinal channel axis ($V_{ua,x}$) or any combination of these loads applied at any location between the outermost anchors of the anchor channel in accordance with [Figure 2-1](#) of this report.

As an alternative to the second system described in the first paragraph of Section 5.2, above, Hilti anchor channels (HAC-(V) 50F, HAC-V 50 Rebar XTS, HAC-(V) 60F, HAC-(V) 70F, HAC-V 70 Rebar XTS) and Hilti channel bolts (HBC-C M16 8.8F, HBC-C M16 8.8G, HBC-C M20 8.8F, HBC-C M20 8.8G), used in conjunction with Hilti HIT-HY 100 adhesive are used to resist static, wind, and seismic (IBC Seismic Design Categories C through F) tension loads (N_{ua}) and shear loads perpendicular to the longitudinal channel axis ($V_{ua,y}$), shear loads acting in the direction of the longitudinal channel axis ($V_{ua,x}$) or any combination of these loads applied at any location in a distance of 23/4 inches (70 mm) or greater to the outermost anchors of the anchor channel in accordance with [Figure 2-1](#) of this report.

- 5.2** The Hilti anchor channel systems must be limited to the use in cracked or uncracked normalweight and lightweight concrete having a specified compressive strength, f_c , of 2,500 psi to 10,000 psi (17.2 MPa to 69.0 MPa) [minimum of 24 MPa is required under ADIBC Appendix L, Section 5.1.1].
- 5.3** Strength design values must be established in accordance with Section 4.1 of this report.
- 5.4** Allowable stress design values are established with Section 4.2 of this report.
- 5.5** Minimum and maximum anchor spacing and minimum edge distance as well as minimum member thickness must comply with the values given in [Tables 8-1](#) and [8-2](#) of this report.
- 5.6** Prior to anchor channel system installation, calculations and details demonstrating compliance with this report must be submitted to the code official. The calculations and details must be prepared by a registered design professional where required by the statutes of the jurisdiction in which the project is to be constructed.
- 5.7** Where not otherwise prohibited in the code, Hilti anchor channel systems are permitted for use with fire-resistance-rated construction provided that at least one of the following conditions is fulfilled:
- anchor channel systems are used to resist wind or seismic forces only.
 - anchor channel systems that support a fire-resistance-rated envelope or a fire-resistance-rated membrane are protected by approved fire-resistance-rated materials, or have been evaluated for resistance to fire exposure in accordance with recognized standards.
 - anchor channel systems are used to support nonstructural elements.
- 5.8** Since an acceptance criteria for evaluating data to determine the performance of anchor channel systems subjected to fatigue or shock loading is unavailable at this time, the use of these anchor channel systems under such conditions is beyond the scope of this report.
- 5.9** Use of hot-dipped galvanized carbon steel anchor channel systems is permitted for exterior exposure or damp environments. In case anchor channels are cut after applying the zinc-coating, only use in dry internal conditions is permitted.
- 5.10** Steel anchoring materials in contact with preservative-treated and fire-retardant-treated wood shall be of zinc-coated carbon steel. The minimum coating weights for zinc-coated steel shall comply with ASTM A153.

5.11 Special inspection must be provided in accordance with Section 4.4 of this report.

5.12 Hilti anchor channel systems are produced under an approved quality-control program with inspections performed by ICC-ES.

6.0 EVIDENCE SUBMITTED

6.1 Data in accordance with [ICC-ES Acceptance Criteria for Anchor Channels in Concrete Elements AC232 \(24\)](#), published April 2025.

6.2 Quality control documentation.

7.0 IDENTIFICATION

7.1 The ICC-ES mark of conformity, electronic labeling, or the evaluation report number (ICC-ES ESR-3520) along with the name, registered trademark, or registered logo of the report holder must be included in the product label.

7.2 The anchor channels are identified by the manufacturer's name, anchor channel type and size and corrosion protection type (e.g. Hilti HAC-(V)(-T) 50F) as well as manufacturing week and year embossed into the channel profile. The marking must be visible after installation of the anchor channel. The evaluation report number (ESR-3520) is given in the installation instructions (MPII) (see [Figure 8-6](#) and [8-7](#)).

7.3 Channel bolts HBC-B, HBC-C, HBC-T and HBC-C-N are identified by packaging labeled with the manufacturer's name, bolt type, bolt diameter and length, bolt grade and corrosion protection type (e.g. HBC-C-N M12x60 8.8F). The bolt type, bolt grade and corrosion protection type is embossed into the channel bolt head.

7.4 Hilti HIT-HY 100 is identified by packaging labeled with the manufacturer's name and evaluation report number (ESR-3574).

7.5 The report holder's contact information is as follows:

HILTI, INC.
7250 DALLAS PARKWAY, SUITE 1000
PLANO, TEXAS 75024
(800) 879-8000
www.hilti.com

NOTATIONS

Equations are provided in units of inches and pounds. For convenience, SI (metric) units are provided in parentheses where appropriate. Unless otherwise noted, values in SI units shall be not used in equations without conversion to units of inches and pounds.

b_{ch}	width of channel, as shown in Figure 8-2 , inch (mm)
c_a	edge distance of anchor channel, measured from edge of concrete member to axis of the nearest anchor as shown in Figure 4-2 , in. (mm)
c_{a1}	edge distance of anchor channel in direction 1 as shown in Figure 4-2 , in. (mm)
c'_{a1}	net distance between edge of the concrete member and the anchor channel: $c'_{a1} = c_{a1} - b_{ch}/2$ in. (mm)
$c_{a1,red}$	reduced edge distance of the anchor channel, as referenced in Eq. (39)
c_{a2}	edge distance of anchor channel in direction 2 as shown in Figure 4-10 , in. (mm)
$c_{a,max}$	maximum edge distance of anchor channel, in. (mm)
$c_{a,min}$	minimum edge distance of anchor channel, in. (mm)
c_{ac}	edge distance required to develop full concrete capacity in absence of reinforcement to control splitting, in. (mm)
c_{cr}	edge distance required to develop full concrete capacity in absence of anchor reinforcement, in. (mm)
$c_{cr,N}$	critical edge distance for anchor channel for tension loading for concrete breakout, in. (mm)
$c_{cr,Nb}$	critical edge distance for anchor channel for tension loading, concrete blow out, in. (mm)
$c_{cr,V}$	critical edge distance for anchor channel for shear loading, concrete edge breakout, in. (mm)
d_1	diameter of head of round anchor, as shown in Figure 8-2 , in. (mm)
d_2	shaft diameter of round anchor, as shown in Figure 8-2 , in. (mm)
d_f	diameter of hole in the fixture, in. (mm)
d_a	diameter of anchor reinforcement, in. (mm)
d_s	diameter of channel bolt, in. (mm)
e_1	distance between shear load and concrete surface, in. (mm)
e_s	distance between the axis of the shear load and the axis of the anchor reinforcement resisting the shear load, in. (mm)
f	distance between anchor head and surface of the concrete, in. (mm)
f_c	specified concrete compressive strength, psi (MPa)
f_{uta}	specified ultimate tensile strength of anchor, psi (MPa)
f_{utc}	specified ultimate tensile strength of channel, psi (MPa)
f_{utb}	specified ultimate tensile strength of channel bolt, psi (MPa)
f_y	specified yield tensile strength of steel, psi (MPa)
f_{ya}	specified yield strength of anchor, psi (MPa)
f_{yc}	specified yield strength of channel, psi (MPa)
f_{ys}	specified yield strength of channel bolt, psi (MPa)
h	thickness of concrete member or test member, as shown in Figure 8-2 , inch (mm)
h_{ch}	height of channel, as shown in Figure 8-2 , in. (mm)
$h_{cr,V}$	critical member thickness, in. (mm)
h_{ef}	effective embedment depth, as shown in Figure 8-2 , in. (mm)
$h_{ef,min}$	minimum effective embedment depth, in. (mm)

$h_{ef,red}$	reduced effective embedment depth, as referenced in Eq. (9), in. (mm)
h_{nom}	nominal embedment depth, as shown in Figure 8-2 , in. (mm)
k	load distribution factor, as referenced in Eq. (1)
k_{cp}	pryout factor
ℓ_A	nominal embedment depth, minus channel height, as shown in Figure 8-2 , in. (mm)
ℓ	lever arm of the shear force acting on the channel bolt, in. (mm)
ℓ_{dh}	development length in tension of deformed bar or deformed wire with a standard hook, measured from critical section to outside end of hook, in. (mm)
ℓ_{in}	influence length of an external load N_{ua} along an anchor channel, in. (mm)
n_{ch}	number of adjacent anchor channels
n_1	number of anchors in direction 1 perpendicular to the edge
s	spacing of anchors in direction of longitudinal axis of channel, in. (mm)
s_{chb}	center-to-center distance between channel bolts in direction of longitudinal axis of channel, in. (mm)
$s_{ch,x}$	center-to-center spacing of adjacent end anchors of anchor channels in linear configuration, in. (mm)
$s_{ch,y}$	axis-to-axis spacing of two anchor channels in parallel configuration, in. (mm)
s_{cr}	anchor spacing required to develop full concrete capacity in absence of anchor reinforcement, in. (mm)
$s_{cr,N}$	critical anchor spacing for tension loading, concrete breakout, in. (mm)
s_{max}	maximum spacing between anchor elements in anchor channels, in. (mm)
s_{min}	minimum spacing between anchor elements in anchor channels, in. (mm)
$s_{cr,Nb}$	critical anchor spacing for tension loading, concrete blow-out, in. (mm)
$s_{cr,V}$	critical anchor spacing for shear loading, concrete edge breakout, in. (mm)
t_h	thickness of head portion of headed anchor, as shown in Figure 8-2 , in. (mm)
x	distance between end of channel and nearest anchor, in. (mm)
z	internal lever arm of the concrete member, in. (mm)
A_{brg}	bearing area of anchor head, in. ² (mm ²)
A_i	ordinate at the position of the anchor i , as illustrated in Figure 4-1 , in. (mm)
$A_{se,N}$	effective cross-sectional area of anchor or channel bolt in tension, in. ² , (mm ²)
$A_{se,V}$	effective cross-sectional area of channel bolt in shear (mm ²)
I_y	moment of inertia of the channel about principal y-axis, in. ⁴ (mm ⁴)
M_1	bending moment on fixture around axis in direction 1, lb-in (Nm)
M_2	bending moment on fixture around axis in direction 2, lb-in (Nm)
$M_{s,flex}$	nominal flexural strength of the anchor channel, lb-in (Nm)
M_{ss}	flexural strength of the channel bolt, lb-in (Nm)
M_{ss}^0	nominal flexural strength of the channel bolt, lb-in (Nm)
$M_{u,flex}$	bending moment on the channel due to tension loads, lb-in (Nm)
N_b	basic concrete breakout strength of a single anchor in tension, lb (N)
N_{ca}	nominal strength of anchor reinforcement to take up tension loads, lb (N)
N_{cb}	concrete breakout strength of a single anchor of anchor channel in tension, lb (N)
N_n	lowest nominal tension strength from all appropriate failure modes under tension, lb (N)
N_p	pullout strength of a single anchor of an anchor channel in tension, lb (N)

N_{pn}	nominal pullout strength of a single anchor of an anchor channel in tension, lb (N)
N_{nc}	nominal tension strength of one anchor from all concrete failure modes (lowest value of N_{cb} (anchor channels without anchor reinforcement to take up tension loads) or N_{ca} (anchor channels with anchor reinforcement to take up tension loads), N_{pn} , and N_{sb})
N_{ns}	nominal steel strength of anchor channel loaded in tension (lowest value of N_{sa} , N_{sc} and N_{sl}), lb (N)
$N_{ns,a}$	nominal tension strength for steel failure of anchor or connection between anchor and channel (lowest value of N_{sa} and N_{sc})
N_{sa}	nominal tensile steel strength of a single anchor, lb (N)
N_{sb}	nominal concrete side-face blowout strength, lb (N)
N_{sb}^0	basic nominal concrete side-face blowout strength, lb (N)
N_{sc}	nominal tensile steel strength of the connection between channel and anchor, lb (N)
N_{sl}	nominal tensile steel strength of the local bending of the channel lips, lb (N)
N_{ss}	nominal tensile strength of a channel bolt, lb (N)
N_{ua}^a	factored tension load on a single anchor of the anchor channel, lb (N)
$N_{ua,i}^a$	factored tension load on anchor i of the anchor channel, lb (N)
N_{ua}^b	factored tension load on a channel bolt, lb (N)
$N_{ua,re}$	factored tension load acting on the anchor reinforcement, lb (N)
$T_{allowable,ASD}$	allowable tension load for use in allowable stress design environments, lb (N)
T_{inst}	installation torque moment given in installation instructions (M _{PII}), lb-in. (N-m)
$V_{x,allowable,ASD}$	allowable shear load in longitudinal channel axis for use in allowable stress design environments, lb (N)
$V_{y,allowable,ASD}$	allowable shear load perpendicular to the channel axis for use in allowable stress design environments, lb (N)
V_b	basic concrete breakout strength in shear of a single anchor, lb (N)
$V_{ca,y}$	nominal strength of the anchor reinforcement of one anchor to take up shear loads perpendicular to the channel axis, lb (N)
$V_{ca,x}$	nominal strength of the anchor reinforcement of one anchor to take up shear loads in longitudinal channel axis, lb (N)
$V_{ca,y,max}$	maximum value of $V_{ca,y}$ of one anchor to be used in design, lb (N)
$V_{cb,y}$	nominal concrete breakout strength in shear perpendicular to the channel axis of an anchor channel, lb (N)
$V_{cb,x}$	nominal concrete breakout strength in shear in longitudinal channel axis of an anchor channel, lb (N)
V_{cp}	nominal pry-out strength of a single anchor ($V_{cp,x} = V_{cp,y}$), lb (N)
$V_{cp,y}$	nominal pry-out strength perpendicular to the channel axis of a single anchor, lb (N)
$V_{cp,x}$	nominal pry-out strength in longitudinal channel axis of a single anchor, lb (N)
$V_{n,y}$	lowest nominal steel strength from all appropriate failure modes under shear perpendicular to the channel axis, lb (N)
$V_{n,x}$	lowest nominal steel strength from all appropriate failure modes under shear loading in longitudinal channel axis, lb (N)

V_{nc}	nominal shear strength of one anchor from all concrete failure modes (lowest value of V_{cb} (anchor channels with anchor reinforcement to take up shear loads) or V_{ca} (anchor channels with anchor reinforcement to take up shear loads) and V_{cp})
V_{ns}	Nominal steel strength of anchor channel loaded in shear (lowest value of V_{sa} , V_{sc} , and V_{sl})
$V_{ns,a}$	nominal shear strength for steel failure of anchor or connection between anchor and channel (lowest value of V_{sa} and V_{sc})
$V_{sa,y}$	nominal shear steel strength perpendicular to the channel axis of a single anchor, lb (N)
$V_{sa,x}$	nominal shear steel strength in longitudinal channel axis of a single anchor, lb (N)
$V_{sa,y,seis}$	nominal seismic shear steel strength perpendicular to the channel axis of a single anchor, lb (N)
$V_{sa,x,seis}$	nominal seismic shear steel strength in longitudinal channel axis of a single anchor, lb (N)
$V_{sc,y}$	nominal shear strength perpendicular to the channel axis of connection between one anchor and the anchor channel, lb (N)
$V_{sc,x}$	nominal shear strength in longitudinal channel axis of connection between one anchor and the anchor channel, lb (N)
$V_{sc,y,seis}$	nominal seismic shear strength perpendicular to the channel axis of connection between one anchor bolt and the anchor channel, lb (N)
$V_{sc,x,seis}$	nominal seismic shear strength in longitudinal channel axis of connection between one anchor bolt and the anchor channel, lb (N)
$V_{sl,y}$	nominal shear steel strength perpendicular to the channel axis of the local bending of the channel lips, lb (N)
$V_{sl,x}$	nominal shear steel strength in longitudinal channel axis of connection between channel bolt and channel lips, lb (N)
$V_{sl,y,seis}$	nominal seismic shear steel strength perpendicular to the channel axis of the local bending of the channel lips, lb (N)
$V_{sl,x,seis}$	nominal seismic shear steel strength in longitudinal channel axis of connection between channel bolt and channel lips, lb (N)
V_{ss}	nominal strength of channel bolt in shear, lb (N)
$V_{ss,M}$	nominal strength of channel bolt in case of shear with lever arm, lb (N)
V_{ua}	factored shear load on anchor channel, lb (N)
$V_{ua,x}$	factored shear load on anchor channel in longitudinal channel axis, lb (N)
$V_{ua,y}$	factored shear load on anchor channel perpendicular to the channel axis, lb (N)
V_{ua}^a	factored shear load on a single anchor of the anchor channel, lb (N)
$V_{ua,x}^a$	factored shear load on a single anchor of the anchor channel in longitudinal channel axis, lb (N)
$V_{ua,y}^a$	factored shear load on a single anchor of the anchor channel perpendicular to the channel axis, lb (N)
$V_{ua,i}^a$	factored shear load on anchor i of the anchor channel, lb (N)
$V_{ua,x,i}^a$	factored shear load on anchor i of the anchor channel in longitudinal channel axis, lb (N)
$V_{ua,y,i}^a$	factored shear load on anchor i of the anchor channel perpendicular to the channel axis, lb (N)
V_{ua}^b	factored shear load on a channel bolt, lb (N)
$V_{ua,x}^b$	factored shear load on a channel bolt in longitudinal channel axis, lb (N)
$V_{ua,y}^b$	factored shear load on a channel bolt perpendicular to the channel axis, lb (N)
α	exponent of interaction equation (see Section 4.1.3.6)

α_{ASD}	conversion factor for allowable stress design (see Section 4.2)
$\alpha_{ch,N}$	factor to account for the influence of channel size on concrete breakout strength in tension
α_M	factor to account for the influence of restraint of fixture on the flexural strength of the channel bolt
$\alpha_{ch,V}$	factor to account for the influence of channel size and anchor diameter on concrete edge breakout strength in shear ($\text{lb}^{1/2}/\text{in}^{1/3}$) ($\text{N}^{1/2}/\text{mm}^{1/3}$)
λ	modification factor for lightweight concrete ($\lambda = 1$ for normal weight concrete)
$\psi_{c,N}$	modification factor to account for influence of cracked or uncracked concrete on concrete breakout strength
$\psi_{c,Nb}$	modification factor to account for influence of cracked or uncracked concrete on concrete blowout strength
$\psi_{c,V}$	modification factor to account for influence of cracked or uncracked concrete for concrete edge breakout strength
$\psi_{co,N}$	modification factor for corner effects on concrete breakout strength for anchors loaded in tension
$\psi_{co,Nb}$	modification factor for corner effects on concrete blowout strength for anchors loaded in tension
$\psi_{co,V}$	modification factor for corner effects on concrete edge breakout strength for anchor channels loaded in shear
$\psi_{cp,N}$	modification factor for anchor channels to control splitting
$\psi_{ed,N}$	modification factor for edge effect on concrete breakout strength for anchors loaded in tension
$\psi_{g,Nb}$	modification factor to account for influence of bearing area of neighboring anchors on concrete blowout strength for anchors loaded in tension
$\psi_{h,Nb}$	modification factor to account for influence of member thickness on concrete blowout strength for anchors loaded in tension
$\psi_{h,V}$	modification factor to account for influence of member thickness on concrete edge breakout strength for anchors channels loaded in shear
$\psi_{s,N}$	modification factor to account for influence of location and loading of neighboring anchors on concrete breakout strength for anchor channels loaded in tension
$\psi_{s,Nb}$	modification factor to account for influence of location and loading of neighboring anchors on concrete blowout strength for anchor channels loaded in tension
$\psi_{s,V}$	modification factor to account for influence of location and loading of neighboring anchors on concrete edge breakout strength for anchor channels loaded in shear

	Tension (Section 4.1.3.2)	Shear perpendicular to the longitudinal channel axis (Section 4.1.3.3)	Shear in direction of longitudinal channel axis (Section 4.1.3.4)	
	Section 4.1.3.2.2	Section 4.1.3.3.2	Section 4.1.3.4.2	
Steel failure	N_{ss} ($N_{ss,seis}$)	Failure of channel bolt	V_{ss} ($V_{ss,seis}$)	Failure of channel bolt (shear without lever arm)
	$M_{s,flex}$ ($M_{s,flex,seis}$)	Flexural failure of channel	$V_{ss,M}$ ($V_{ss,M,seis}$)	Failure of channel bolt (shear with lever arm)
	N_{sl} ($N_{sl,seis}$)	Flexural failure of channel lips	$V_{sl,y}$ ($V_{sl,y,seis}$)	Flexural failure of channel lip
	N_{sc} ($N_{sc,seis}$)	Failure of connection between channel and anchor	$V_{sc,y}$ ($V_{sc,y,seis}$)	Failure of connection between channel and anchor
	N_{sa} ($N_{sa,seis}$)	Failure of anchor	$V_{sa,y}$ ($V_{sa,y,seis}$)	Failure of anchor
	Sections 4.1.3.2.3, 4.1.3.2.4, and 4.1.3.2.5	Sections 4.1.3.3.3 and 4.1.3.3.4	Sections 4.1.3.4.3 and 4.1.3.4.4	
Concrete failure	N_{cb} ($N_{cb,seis}$)	Concrete cone failure (without anchor reinforcement)	$V_{cb,x}$ ($V_{cb,x,seis}$)	Concrete edge failure (without anchor reinforcement)
	N_{ca} ($N_{ca,seis}$)	Anchor reinforcement	$V_{ca,y}$ ($V_{ca,y,seis}$)	Anchor reinforcement
	N_{pn} ($N_{pn,seis}$)	Pullout failure	$V_{cp,y}$ ($V_{cp,y,seis}$)	Pryout failure
	N_{sb} ($N_{sb,seis}$)	Blow out failure		
Combined Tension and Shear Loads (Section 4.1.3.6)				
Steel failure	N_{ss}, V_{ss} ($N_{ss,seis}, V_{ss,seis}$)	For channel bolts Eq. (45) shall be satisfied.		
	$N_{ns,a}, V_{ns,a,y}, V_{ns,a,x}$ ($N_{ns,a,seis}, V_{ns,a,y,seis}, V_{ns,a,x,seis}$)	For anchor and connection between anchor and channel Eq. (46) shall be satisfied.		
	$N_{sl}, M_{s,flex}, V_{sl,y}, V_{sl,x}$ ($N_{sl,seis}, M_{s,flex,seis}, V_{sl,y,seis}, V_{sl,x,seis}$)	At the point of load application Eq. (47) and Eq. (48) shall be satisfied.		
Concrete failure	$N_{nc}, V_{nc,y}, V_{nc,x}$ ($N_{nc,seis}, V_{nc,y,seis}, V_{nc,x,seis}$)	For concrete failure modes Eq. (49 or 50) shall be satisfied.		

FIGURE 8-1: OVERVIEW REQUIRED VERIFICATIONS FOR STATIC LOADING (SEISMIC LOADING)

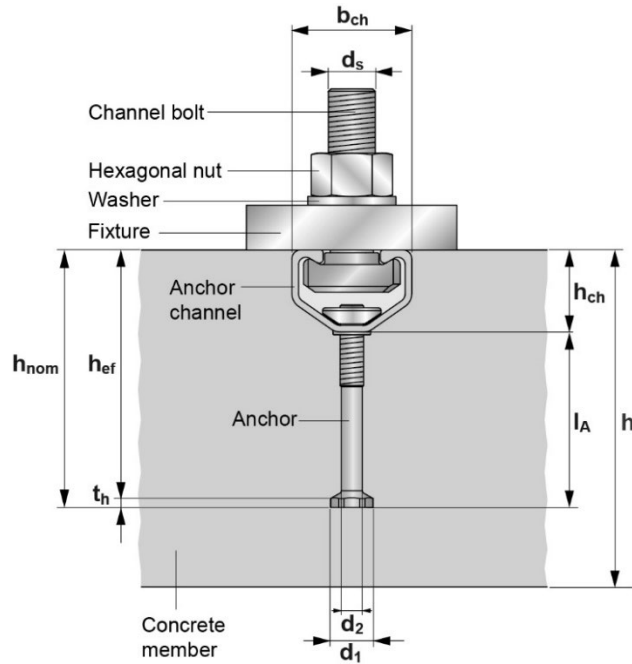

FIGURE 8-2: DIMENSIONS OF ANCHOR CHANNEL SYSTEM

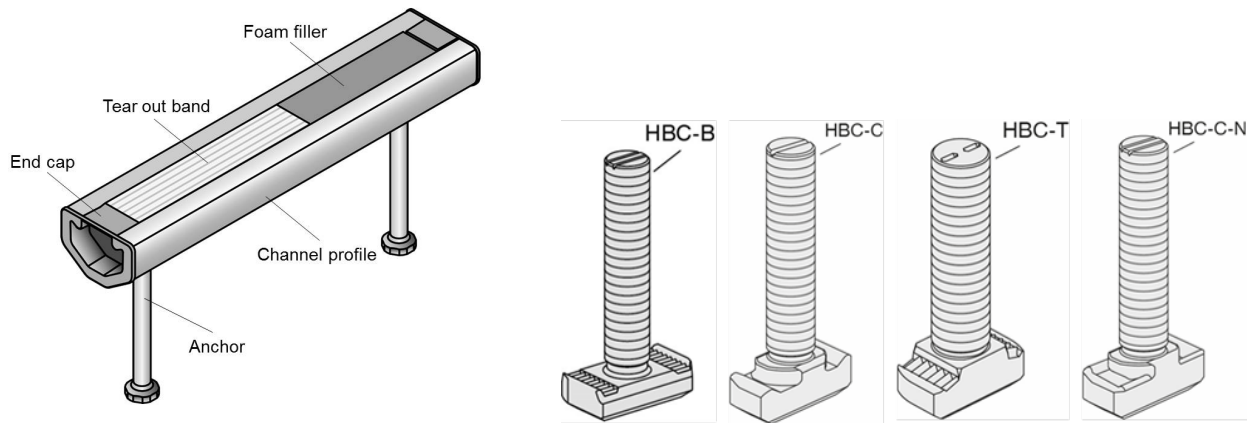

FIGURE 8-3: ANCHOR CHANNELS HAC(-V) AND HAC(-V)-T AND CHANNEL BOLTS HBC-B, HBC-C, HBC-T AND HBC-C-N

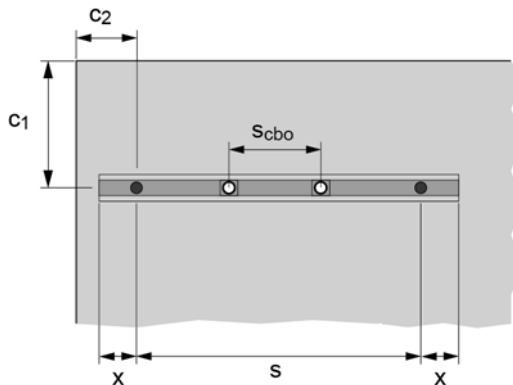

FIGURE 8-4: POSITION OF ANCHOR CHANNEL AND CHANNEL BOLTS

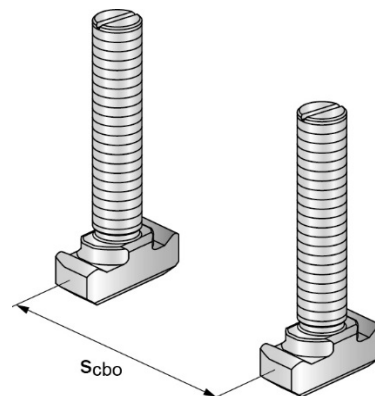

FIGURE 8-5: CHANNEL BOLT SPACING S_{cbo}

TABLE 8-1—GEOMETRIC PARAMETERS FOR HILTI ANCHOR CHANNELS (HAC AND HAC-T)

Criteria	Symbol	Units	Anchor channel sizes						
			HAC-30	HAC-40	HAC-50	HAC-T50	HAC-60	HAC-70	HAC-T70
Channel height	h_{ch}	in (mm)	1.01 (25.6)	1.10 (28.0)	1.22 (31.0)		1.40 (35.5)	1.57 (40.0)	
Channel width	b_{ch}	in (mm)	1.63 (41.3)	1.61 (40.9)	1.65 (41.9)		1.71 (43.4)	1.79 (45.4)	
Moment of inertia	I_y	in ⁴ (mm ⁴)	0.0369 (15,349)	0.0516 (21,463)	0.0796 (33,125)	0.0770 (32,049)	0.1392 (57,930)	0.2293 (95,457)	0.2215 (92,192)
Minimum anchor spacing	s_{min}	in (mm)	1.97 (50)	3.94 (100)					
Maximum anchor spacing	s_{max}	in (mm)	9.84 (250)						
Minimum effective embedment depth	$h_{ef,min}$	in (mm)	2.68 (68)	3.58 (91)	4.17 (106)		5.83 (148)	6.89 (175)	
Nominal embedment depth	h_{nom}	in (mm)	$h_{ef} + t_h$						
Thickness of the anchor head	t_h	in (mm)	0.08 (2.0)	0.12 (3.0)	0.14 (3.5)		0.18 (4.5)	0.20 (5.0)	
Minimum edge distance for normal-weight and sand-lightweight concrete	$c_{a,min}$	in (mm)	1.97 (50)	1.97 (50)	1.97 (50)		2.95 (75)	2.95 (75)	
Minimum edge distance for all-lightweight concrete		in (mm)	2.95 (75)	2.95 (75)	2.95 (75)		2.95 (75)	2.95 (75)	
Minimum end spacing	x_{min}	in (mm)	0.98 (25)	0.98 (25)	0.98 (25)		0.98 (25)	0.98 (25)	
Anchor shaft diameter	d_2	in (mm)	0.21 (5.35)	0.28 (7.19)	0.36 (9.03)		0.36 (9.03)	0.43 (10.86)	
Head diameter ¹	d_1	in (mm)	0.45 (11.5)	0.69 (17.5)	0.77 (19.5)		0.77 (19.5)	0.91 (23.0)	
Net bearing area of the anchor head	A_{brg}	in ² (mm ²)	0.138 (89)	0.324 (209)	0.400 (258)		0.400 (258)	0.552 (356)	
Minimum concrete member thickness	h_{min}	in (mm)	3.15 (80)	4.13 (105)	4.92 (125)		6.61 (168)	7.72 (196)	

¹The head diameter is the inner diameter of the hexagonal shaped head, and does not fully reflect the cross sectional area of the anchor head.

TABLE 8-2—GEOMETRIC PARAMETERS FOR HILTI ANCHOR CHANNELS (HAC-V AND HAC-V-T)

Criteria	Symbol	Units	Anchor channel sizes								
			HAC-V-T 30	HAC-V 35	HAC-V 40	HAC-V 50 / (Rebar XTS)	HAC-V-T 50 / (Rebar XTS)	HAC-V 60	HAC-V 70 / (Rebar XTS)	HAC-V-T 70 / (Rebar XTS)	
Channel height	h_{ch}	in (mm)	1.01 (25.6)	1.10 (28.0)	1.10 (28.0)	1.22 (31.0)		1.40 (35.5)		1.57 (40.0)	
Channel width	b_{ch}	in (mm)	1.63 (41.3)	1.61 (40.9)	1.61 (40.9)	1.65 (41.9)		1.71 (43.4)		1.79 (45.4)	
Moment of inertia	I_y	in ⁴ (mm ⁴)	0.0369 (15,349)	0.0516 (21,463)	0.0516 (21,463)	0.0796 (33,125)	0.0770 (32,049)	0.1392 (57,930)		0.2293 (95,457)	0.2215 (92,192)
Minimum anchor spacing	s_{min}	in (mm)	1.97 (50)	3.94 (100)		5.91/3.94 (150)/(100)	5.91/3.94 (150)/(100)	3.94 (100)	5.91 (150)	3.94 / 5.91 (100) / (150)	
Maximum anchor spacing	s_{max}	in (mm)	9.84 (250)								
Minimum effective embedment depth	$h_{ef,min}$	in (mm)	2.68 (68)	3.58 (91)	4.32 (110)	2.80 (71)		5.83 (148)	7.2 (183)	6.89 / 11.61 (175) / (295)	
Nominal embedment depth	h_{nom}	in (mm)	$h_{ef} + t_h$								
Thickness of the anchor head	t_h	in (mm)	0.08 (2.0)	0.12 (3.0)	0.12 (3.0)	0.14 (3.5)		0.18 (4.5)		0.20 (5.0)	
Minimum edge distance for normal-weight and sand-lightweight concrete	$c_{a,min}$	in (mm)	1.97 (50)	1.97 (50)	1.97 (50)	3.94 / 1.97 (100) / (50)	3.94 / 1.97 (100) / (50)	2.95 (75)	2.50 (63.5)	2.95 / 2.50 (75) / (63.5)	
Minimum edge distance for all-lightweight concrete		in (mm)	2.95 (75)	2.95 (75)	2.95 (75)	4.92 ² / 2.95 (125) ² / (75)	4.92 ² / 2.95 (125) ² / (75)	2.95 (75)	2.50 (63.5)	2.95 / 2.50 (75) / (63.5)	
Minimum end spacing	x_{min}	in (mm)	0.98 (25)	0.98 (25)	0.98 (25)	0.98 (25)		0.98 (25)		0.98 (25)	
Anchor shaft diameter	d_2	in (mm)	0.21 (5.35)	0.28 (7.19)	0.28 (7.19)	0.36 (9.03)		0.36 (9.03)		0.43 (10.86)	
Head diameter ¹	d_1	in (mm)	0.45 (11.5)	0.69 (17.5)	0.69 (17.5)	0.77 (19.5)		0.77 (19.5)		0.91 (23.0)	
Net bearing area of the anchor head ¹	A_{brg}	in ² (mm ²)	0.138 (89)	0.324 (209)	0.324 (209)	0.400 (258)		0.400 (258)		0.552 (356)	
Anchor Reinforcing bar size	d_R	in (mm)	-			0.39 (10.0)		-		0.55 (14.0)	
Length of deformed reinforcing bar	l_R	in (mm)	-			per ACI 318-19 Sec 25.5		-		per ACI 318-19 Sec 25.5	
Minimum concrete member thickness for round anchors	h_{min}	in (mm)	3.15 (80)	4.13 (105)	4.92 (125)	3.54 / 4.92 (90) ² / (125)	3.54 / 4.92 (90) ² / (125)	6.61 (168)	19.69 ³ (500) ³	7.72 / 19.69 ³ (196) / (500) ³	7.72 / 19.69 ³ (196) / (500) ³

¹The head diameter is the inner diameter of the hexagonal shaped head, and does not fully reflect the cross sectional area of the anchor head.

²Applicable for all channel bolt sizes, but HBC-C-N M16 and HBC-C-N M20.

³For normal weight concrete the minimum concrete member thickness can be reduced to 15.75 in (400 mm).

TABLE 8-3—INSTALLATION TORQUE FOR HILTI CHANNEL BOLTS (HBC-B, HBC-C, HBC-T AND HBC-C-N) AND COMPATIBILITY WITH THE MACHINE TORQUEING WITH SIW 6AT-A22 IN COMBINATION WITH SI-AT-A22

Bolt type	Units	Installation torque T_{inst} (Installation type A) ¹					Installation torque T_{inst} (Installation type B) ²			Machine torquing with SIW 6AT-A22 and SI-AT-A22 ³
		HAC(-V-T) 30	HAC(-V) 35 HAC(-V) 40 HAC(-V) 50	HAC(-V) 60 HAC(-V) 70	HAC(-V)-T 50 (Rebar XTS) HAC(-V)-T 70 (Rebar XTS)	HAC(-V-T) 30	HAC(-V) 35 HAC(-V) 40 HAC(-V) 50 HAC(-V) 60 HAC(-V) 70	HAC(-V)-T 50 (Rebar XTS) HAC(-V)-T 70 (Rebar XTS)		
HBC-B M10 4.6	ft-lb (Nm)	11 (15)	-	-	-	11 (15)	-	-	yes	
HBC-B M12 4.6	ft-lb (Nm)	19 (25)	-	-	-	19 (25)	-	-	yes	
HBC-C M12 8.8	ft-lb (Nm)	-	19 (25)	-	-	-	55 (75)	-	yes	
HBC-T M12 8.8	ft-lb (Nm)	-	-	55 (75)	-	-	-	55 (75)	yes	
HBC-C-N M12 8.8	ft-lb (Nm)	-	55 (75)	-	-	-	55 (75)	-	yes	
HBC-C M16 4.6	ft-lb (Nm)	-	44 (60)	-	-	-	44 (60)	-	yes	
HBC-C M16 50 R	ft-lb (Nm)	-	44 (60)	-	-	-	44 (60)	-	yes	
HBC-C M16 8.8	ft-lb (Nm)	-	44 (60)	-	-	-	136 (185)	-	yes	
HBC-T M16 8.8	ft-lb (Nm)	-	-	74 (100)	-	-	-	136 (185)	yes	
HBC-C-N M16 8.8	ft-lb (Nm)	-	136 (185)	-	-	-	136 (185)	-	no	
HBC-C M20 8.8	ft-lb (Nm)	-	52 (70)	78 (105)	89 (120)	-	236 (320)	-	yes	
HBC-T M20 8.8	ft-lb (Nm)	-	-	-	89 (120)	-	-	236 (320)	no	
HBC-C-N M20 8.8	ft-lb (Nm)	-	236 (320)	-	-	-	236 (320)	-	no	

¹ Installation type A: The fixture is in contact with the channel profile and the concrete surface

² Installation type B: The fixture is fastened to the anchor channel by suitable steel part (e.g. square plate washer), fixture is in contact with the channel profile only.

³For channel bolts with multiple torque values listed, the machine torquing will apply the minimum listed torque value.

TABLE 8-4—TENSION STEEL STRENGTH DESIGN INFORMATION FOR HILTI ANCHOR CHANNELS (HAC AND HAC-T) WITH HILTI CHANNEL BOLTS (HBC-B, HBC-C, HBC-T AND HBC-C-N)

Criteria	Symbol	Units	Anchor channel sizes						
			HAC-30	HAC-40	HAC-50	HAC-T50	HAC-60	HAC-70	HAC-T70
Nominal tensile steel strength for local failure of channel lips	N_{sl}	lb (kN)	3,935 (17.5)	5,620 (25.0)	7,865 (35.0)		11,240 (50.0)	15,960 (71.0)	
Nominal tensile steel strength for local failure of channel lips for seismic design	$N_{sl,seis}$	lb (kN)	3,935 (17.5)	5,620 (25.0)	7,865 (35.0)		7,865 (35.0)	15,960 (71.0)	
Strength reduction factor for local failure of channel lips ¹	ϕ	-	0.75						
Nominal tensile steel strength of a single anchor	N_{sa}	lb (kN)	3,890 (17.3)	7,080 (31.5)	11,240 (50.0)		11,240 (50.0)	16,320 (72.6)	
Nominal tensile steel strength of a single anchor for seismic design	$N_{sa,seis}$	lb (kN)	3,890 (17.3)	7,080 (31.5)	11,240 (50.0)		11,240 (50.0)	16,320 (72.6)	
Strength reduction factor for anchor failure ¹	ϕ	-	0.75 (0.80)	0.65 (0.75)	0.75				
Nominal tensile steel strength of connection between anchor and channel	N_{sc}	lb (kN)	3,935 (17.5)	5,620 (25.0)	7,865 (35.0)		11,240 (50.0)	15,960 (71.0)	
Nominal tensile steel strength of connection between anchor and channel for seismic design	$N_{sc,seis}$	lb (kN)	3,935 (17.5)	5,620 (25.0)	7,865 (35.0)		7,865 (35.0)	15,960 (71.0)	
Strength reduction factor for failure of connection between anchor and channel ¹	ϕ	-	0.75						
Nominal bending strength of the anchor channel with HBC-B	$M_{s,flex}$	lb-in (Nm)	5,955 (673)	-	-	-	-	-	-
Nominal bending strength of the anchor channel with HBC-C		lb-in (Nm)	-	10,050 (1,136)	14,125 (1,596)	-	19,355 (2,187)	28,000 (3,164)	-
Nominal bending strength of the anchor channel with HBC-T		lb-in (Nm)	-	-	-	14,125 (1,596)	-	-	26,331 (2,975)
Nominal bending strength of the anchor channel with HBC-C-N		lb-in (Nm)	-	8,673 (980)	11,903 (1,345)	-	19,081 (2,156)	26,594 (3,005)	-
Nominal bending strength of the anchor channel for seismic design with HBC-B	$M_{s,flex,seis}$	lb-in (Nm)	5,955 (673)	-	-	-	-	-	-
Nominal bending strength of the anchor channel for seismic design with HBC-C		lb-in (Nm)	-	10,050 (1,136)	14,125 (1,596)	-	14,125 (1,596)	28,000 (3,164)	-
Nominal bending strength of the anchor channel for seismic design with HBC-T		lb-in (Nm)	-	-	-	14,125 (1,596)	-	-	26,331 (2,975)
Nominal bending strength of the anchor channel for seismic design with HBC-C-N		lb-in (Nm)	-	8,673 (980)	11,903 (1,345)	-	11,903 (1,345)	26,594 (3,005)	-
Strength reduction factor for bending failure ¹	ϕ	-	0.85						

¹The tabulated value of ϕ applies when the load combinations of Section 1605.1 of the 2024 IBC or ACI 318-19 Section 5.3 are used.

TABLE 8-5—TENSION STEEL STRENGTH DESIGN INFORMATION FOR HILTI ANCHOR CHANNELS (HAC-V AND HAC-V-T) WITH HILTI CHANNEL BOLTS (HBC-B, HBC-C, HBC-T AND HBC-C-N)

Criteria	Symbol	Units	Anchor channel sizes							
			HAC-V-T 30	HAC-V 35	HAC-V 40	HAC-V 50 (Rebar XTS)	HAC-V-T 50 (Rebar XTS)	HAC-V 60	HAC-V 70 (Rebar XTS)	HAC-V-T 70 (Rebar XTS)
Nominal tensile steel strength for local failure of channel lips	N_{sl}	lb (kN)	4,474 (19.9)	7,059 (31.4)		9,217 (41.0)	9,217 (41.0)	12,364 (55.0)	15,960 (71.0)	15,960 (71.0)
Nominal tensile steel strength for local failure of channel lips for seismic design	$N_{sl,seis}$	lb (kN)	4,474 (19.9)	7,059 (31.4)		8,992 (40.0)	9,217 (41.0)	8,992 (40.0)	15,960 (71.0)	15,960 (71.0)
Strength reduction factor for local failure of channel lips ¹	ϕ	-	0.75							
Nominal tensile steel strength of a single anchor	N_{sa}	lb (kN)	4,092 (18.2)	7,059 (31.4)		12,364 ² (55.0) ²	9,442 (42.0)	12,364 (55.0)	16,861 (75.0)	16,861 (75.0)
Nominal tensile steel strength of a single anchor for seismic design	$N_{sa,seis}$	lb (kN)	4,092 (18.2)	7,059 (31.4)		12,364 ² (55.0) ²	9,442 (42.0)	12,364 (55.0)	16,861 (75.0)	16,861 (75.0)
Strength reduction factor for anchor failure ¹	ϕ	-	0.75							
Nominal tensile steel strength of connection between anchor and channel	N_{sc}	lb (kN)	4,092 (18.2)	7,059 (31.4)		9,442 (42.0)	9,442 (42.0)	12,364 (55.0)	15,960 (71.0)	16,861 (75.0)
Nominal tensile steel strength of connection between anchor and channel for seismic design	$N_{sc,seis}$	lb (kN)	4,092 (18.2)	7,059 (31.4)		8,992 (40.0)	9,442 (42.0)	8,992 (40.0)	15,960 (71.0)	16,861 (75.0)
Strength reduction factor for failure of connection between anchor and channel ¹	ϕ	-	0.75							
Nominal bending strength of the anchor channel with HBC-B	$M_{s,flex}$	lb-in (Nm)	6,921 (782)	-		-	-	-	-	-
Nominal bending strength of the anchor channel with HBC-C		lb-in (Nm)	-	11,665 (1,318)		16,400 (1,853)	-	22,463 (2,538)	32,465 (3,668)	-
Nominal bending strength of the anchor channel with HBC-T		lb-in (Nm)	-	-		-	16,400 (1,853)	-	-	30,562 (3,453)
Nominal bending strength of the anchor channel with HBC-C-N		lb-in (Nm)	-	10,063 (1,137)		13,816 (1,561)	-	22,153 (2,503)	30,871 (3,488)	-
Nominal bending strength of the anchor channel for seismic design with HBC-B	$M_{s,flex,seis}$	lb-in (Nm)	6,921 (782)	-		-	-	-	-	-
Nominal bending strength of the anchor channel for seismic design with HBC-C		lb-in (Nm)	-	11,665 (1,318)		14,763 (1,668)	-	14,763 (1,668)	32,465 (3,668)	-
Nominal bending strength of the anchor channel for seismic design with HBC-T		lb-in (Nm)	-	-		-	14,763 (1,668)	-	-	30,562 (3,453)
Nominal bending strength of the anchor channel for seismic design with HBC-C-N		lb-in (Nm)	-	10,063 (1,137)		12,435 (1,405)	-	12,435 (1,405)	30,871 (3,488)	-
Strength reduction factor for bending failure ¹	ϕ	-	0.85							

¹The tabulated value of ϕ applies when the load combinations of Section 1605.1 of the 2024 IBC or ACI 318-19 Section 5.3 are used.

²For type Rebar XTS: $N_{sa} = N_{sa,seis} = 9,599$ lb (42.7 kN)

TABLE 8-6—TENSION CONCRETE STRENGTH DESIGN INFORMATION FOR HILTI ANCHOR CHANNELS (HAC (-V) AND HAC (-V) -T)

Criteria	Symbol	Units	Anchor channel sizes				
			HAC(-V-T) 30	HAC-V 35 HAC(-V) 40	HAC(-V) 50 ² (Rebar XTS) HAC(-V)-T 50 ² (Rebar XTS)	HAC(-V) 60	HAC(-V) 70 (Rebar XTS) HAC(-V)-T70 (Rebar XTS)
Edge distance required to develop full concrete capacity in absence of anchor reinforcement	C_{ac}	in (mm)	8.03 (204)	10.75 (273)	12.52 (318)	17.48 (444)	20.67 (525)
Strength reduction factor for tension, concrete failure modes ¹	ϕ	-	0.70				

¹The tabulated value of ϕ applies when both the load combinations of Section 1605.1 of the 2024 IBC or ACI 318-19 Section 5.3 are used and the requirements of ACI 318-19 Table 17.5.3(b) for supplementary reinforcement not present are met. For installations where complying supplementary reinforcement can be verified, the ϕ factors described in ACI 318-19 Table 17.5.3(b) are allowed.

²The value $\alpha_{ch,N}$ for concrete breakout failure should be taken as 0.75 for HAC-V(-T) 50 with $h_{ef} = 2.8$ in (71mm). For $h_{ch}/h_{ef} \leq 0.4$ the concrete breakout failure can be directly calculated according to Eq. 17.6.2.7b of ACI 318-19.

TABLE 8-7—SHEAR STEEL STRENGTH DESIGN INFORMATION FOR HILTI ANCHOR CHANNELS (HAC AND HAC-T) WITH HILTI CHANNEL BOLTS (HBC-B, HBC-C, HBC-T AND HBC-C-N)

Criteria	Symbol	Units	Anchor channel sizes				
			HAC-30	HAC-40	HAC-50 HAC-T50	HAC-60	HAC-70 HAC-T70
Nominal shear steel strength for local failure of channel lips	$V_{sl,y}$	lb (kN)	5,620 (25.0)	7,835 (34.8)	10,675 (47.4)	16,205 (72.0)	21,550 (95.8)
Nominal shear steel strength for local failure of the channel lips for seismic design	$V_{sl,y,seis}$	lb (kN)	5,620 (25.0)	7,835 (34.8)	10,675 (47.4)	10,675 (47.4)	21,550 (95.8)
Strength reduction factor for local failure of channel lips ¹	ϕ	-	0.75				
Nominal shear steel strength of a single anchor	$V_{sa,y}$	lb (kN)	5,620 (25.0)	8,903 (39.6)	12,050 (53.6)	17,378 (77.3)	25,790 (114.7)
Nominal shear steel strength of a single anchor for seismic design	$V_{sa,y,seis}$	lb (kN)	5,620 (25.0)	8,903 (39.6)	10,675 (47.4)	10,675 (47.4)	21,550 (95.8)
Strength reduction factor anchor failure ¹	ϕ	-	0.75	0.65	0.75		
Nominal shear steel strength of connection between anchor and channel	$V_{sc,y}$	lb (kN)	5,620 (25.0)	8,903 (39.6)	12,050 (53.6)	17,378 (77.3)	25,790 (114.7)
Nominal shear steel strength of connection between anchor and channel for seismic design	$V_{sc,y,seis}$	lb (kN)	5,620 (25.0)	8,903 (39.6)	10,675 (47.4)	10,675 (47.4)	21,550 (95.8)
Strength reduction factor for failure of connection between anchor and channel ¹	ϕ	-	0.75				
Nominal shear steel strength of connection between anchor and channel	$V_{sc,x}$	lb (kN)	2,360 (10.5)	3,552 (15.8)	5,240 (23.3)	6,722 (29.9)	9,590 (42.6)
Nominal shear steel strength of connection between anchor and channel for seismic design	$V_{sc,x,seis}$	lb (kN)	2,360 (10.5)	3,552 (15.8)	5,240 (23.3)	5,240 (23.3)	9,590 (42.6)
Strength reduction factor for failure of connection between anchor and channel ¹	ϕ	-	0.75				
Nominal shear steel strength of a single anchor	$V_{sa,x}$	lb (kN)	2,340 (10.4)	4,249 (18.9)	6,740 (30.0)	6,740 (30.0)	9,800 (43.6)
Nominal shear steel strength of a single anchor for seismic design	$V_{sa,x,seis}$	lb (kN)	2,340 (10.4)	4,249 (18.9)	6,740 (30.0)	6,740 (30.0)	9,800 (43.6)
Strength reduction factor anchor failure ¹	ϕ	-	0.75				

¹The tabulated value of ϕ applies when the load combinations of Section 1605.1 of the 2024 IBC or ACI 318-19 Section 5.3 are used.

TABLE 8-8—SHEAR STEEL STRENGTH DESIGN INFORMATION FOR HILTI ANCHOR CHANNELS (HAC-V AND HAC-V-T) WITH HILTI CHANNEL BOLTS (HBC-B, HBC-C, HBC-T AND HBC-C-N)

Criteria	Symbol	Units	Anchor channel sizes						
			HAC-V-T 30	HAC-V 35 HAC-V 40	HAC-V 50 (Rebar XTS)	HAC-V-T 50 (Rebar XTS)	HAC-V 60	HAC-V 70 Rebar XTS	HAC-V-T 70 Rebar XTS
Nominal shear steel strength for local failure of channel lips	$V_{sl,y}$	lb (kN)	6,227 (27.7)	8,408 (37.4)	12,364 (55.0)	13,601 (60.5)	18,637 (82.9)	23,133 (102.9)	26,730 (118.8)
Nominal shear steel strength for local failure of the channel lips for seismic design	$V_{sl,y,seis}$	lb (kN)	6,227 (27.7)	8,408 (37.4)	12,364 (55.0)	13,601 (60.5)	12,364 (55.0)	23,133 (102.9)	26,730 (118.8)
Strength reduction factor for local failure of channel lips ¹	ϕ	-	0.75						
Nominal shear steel strength of a single anchor	$V_{sa,y}$	lb (kN)	6,047 (26.9)	9,554 (42.5)	12,927 (57.5)	13,016 (57.9)	18,637 (82.9)	26,190 (116.5)	25,808 (114.8)
Nominal shear steel strength of a single anchor for seismic design	$V_{sa,y,seis}$	lb (kN)	6,047 (26.9)	9,554 (42.5)	12,927 (57.5)	13,016 (57.9)	12,927 (57.5)	26,190 (116.5)	25,808 (114.8)
Strength reduction factor anchor failure ¹	ϕ	-	0.75						
Nominal shear steel strength of connection between anchor and channel	$V_{sc,y}$	lb (kN)	6,047 (26.9)	9,554 (42.5)	12,927 (57.5)	13,016 (57.9)	18,637 (82.9)	26,190 (116.5)	25,808 (114.8)
Nominal shear steel strength of connection between anchor and channel for seismic design	$V_{sc,y,seis}$	lb (kN)	6,047 (26.9)	9,554 (42.5)	12,927 (57.5)	13,016 (57.9)	12,927 (57.5)	26,190 (116.5)	25,808 (114.8)
Strength reduction factor for failure of connection between anchor and channel ¹	ϕ	-	0.75						
Nominal shear steel strength of connection between anchor and channel	$V_{sc,x}$	lb (kN)	2,450 (10.9)	4,226 (18.8)	5,665 (25.2)	5,665 (25.2)	7,419 (33.0)	9,599 (42.7)	10,116 (45.0)
Nominal shear steel strength of connection between anchor and channel for seismic design	$V_{sc,x,seis}$	lb (kN)	2,450 (10.9)	4,226 (18.8)	5,665 (25.2)	5,665 (25.2)	5,665 (25.2)	9,599 (42.7)	10,116 (45.0)
Strength reduction factor for failure of connection between anchor and channel ¹	ϕ	-	0.75						
Nominal shear steel strength of a single anchor	$V_{sa,x}$	lb (kN)	2,450 (10.9)	4,226 (18.8)	7,419 ² (33.0)	7,419 ² (33.0)	7,419 (33.0)	10,116 (45.0)	10,116 (45.0)
Nominal shear steel strength of a single anchor for seismic design	$V_{sa,x,seis}$	lb (kN)	2,450 (10.9)	4,226 (18.8)	7,419 ² (33.0)	7,419 ² (33.0)	7,419 (33.0)	10,116 (45.0)	10,116 (45.0)
Strength reduction factor anchor failure ¹	ϕ	-	0.75						

¹The tabulated value of ϕ applies when the load combinations of Section 1605.1 of the 2024 IBC or ACI 318-19 Section 5.3 are used.

²For type Rebar XTS: $V_{sa,x} = V_{sa,x,seis} = 5,755$ lb (25.6 kN)

TABLE 8-9—STEEL STRENGTH DESIGN INFORMATION FOR SHEAR ACTING IN LONGITUDINAL DIRECTION OF THE CHANNEL AXIS FOR HILTI ANCHOR CHANNELS (HAC-T) WITH HILTI CHANNEL BOLTS (HBC-T)

Criteria	Symbol	Bolt type	Units	Anchor channel sizes		
				HAC-30	HAC-T50	HAC-T70
Nominal shear steel strength of connection between channel lips and channel bolts	$V_{sl,x}$	HBC-B M12	lb (kN)	790 (3.5)	-	
		HBC-T M12	lb (kN)	-	3,395 (15.1)	
		HBC-T M16	lb (kN)		4,519 (20.1)	
		HBC-T M20	lb (kN)		4,519 (20.1)	
Nominal shear steel strength of connection between channel lips and channel bolts for seismic design	$V_{sl,x,seis}$	HBC-B M12	lb (kN)	790 (3.5)	-	
		HBC-T M12	lb (kN)	-	3,395 (15.1)	
		HBC-T M16	lb (kN)		4,519 (20.1)	
		HBC-T M20	lb (kN)		4,519 (20.1)	
Strength reduction factor for failure of connection between channel lips and channel bolts ¹ (periodic inspection)	ϕ	HBC-B M12	-	0.55	-	
		HBC-T M12		-	-	
		HBC-T M16			0.65	
		HBC-T M20			-	
Strength reduction factor for failure of connection between channel lips and channel bolts ¹ (continuous inspection)	ϕ	HBC-B M12	-	0.55	-	
		HBC-T M12		-	-	
		HBC-T M16			0.75	
		HBC-T M20			-	

¹The tabulated value of ϕ applies when the load combinations of Section 1605.1 of the 2024 IBC or ACI 318-19 Section 5.3 are used.

TABLE 8-10—STEEL STRENGTH DESIGN INFORMATION FOR SHEAR ACTING IN LONGITUDINAL DIRECTION OF THE CHANNEL AXIS FOR HILTI ANCHOR CHANNELS (HAC-V-T) WITH HILTI CHANNEL BOLTS (HBC-B AND HBC-T)

Criteria	Symbol	Bolt type	Units	Anchor channel sizes		
				HAC-V-T 30	HAC-V-T 50 (Rebar XTS)	HAC-V-T 70 (Rebar XTS)
Nominal shear steel strength of connection between channel lips and channel bolts	$V_{sl,x}$	HBC-B M12	lb (kN)	790 (3.5)	-	
		HBC-T M12	lb (kN)	-		
		HBC-T M16	lb (kN)		4,519 (20.1)	
		HBC-T M20	lb (kN)		4,519 (20.1)	
Nominal shear steel strength of connection between channel lips and channel bolts for seismic design	$V_{sl,x,seis}$	HBC-B M12	lb (kN)	790 (3.5)	-	
		HBC-T M12	lb (kN)	-		
		HBC-T M16	lb (kN)		4,519 (20.1)	
		HBC-T M20	lb (kN)		4,519 (20.1)	
Strength reduction factor for failure of connection between channel lips and channel bolts ¹ (periodic inspection)	ϕ	HBC-B M12	-	0.55	-	
		HBC-T M12		-		
		HBC-T M16				
		HBC-T M20				
Strength reduction factor for failure of connection between channel lips and channel bolts ¹ (continuous inspection)	ϕ	HBC-B M12	-	0.55	-	
		HBC-T M12		-		
		HBC-T M16				
		HBC-T M20				

¹The tabulated value of ϕ applies when the load combinations of Section 1605.1 of the 2024 IBC or ACI 318-19 Section 5.3 are used.

TABLE 8-11—STEEL STRENGTH DESIGN INFORMATION FOR SHEAR ACTING IN LONGITUDINAL DIRECTION OF THE CHANNEL AXIS FOR HILTI ANCHOR CHANNELS (HAC) WITH HILTI CHANNEL BOLTS (HBC-C-N)

Criteria	Symbol	Bolt type HBC-C-N	Units	Anchor channel sizes			
				HAC-40	HAC-50	HAC-60	HAC-70
Nominal shear steel strength of connection between channel lips and channel bolts	$V_{sl,x}$	M12 ²	lb (kN)	1,920 (8.5)	1,920 (8.5)	1,920 (8.5)	1,920 (8.5)
		M16	lb (kN)	4,420 (19.7)	4,420 (19.7)	4,420 (19.7)	4,420 (19.7)
		M20	lb (kN)	- -	5,425 (24.1)	5,425 (24.1)	5,425 (24.1)
Nominal shear steel strength of connection between channel lips and channel bolts for seismic design	$V_{sl,x,seis}$	M12 ²	lb (kN)	1,920 (8.5)	1,920 (8.5)	1,920 (8.5)	1,920 (8.5)
		M16	lb (kN)	4,420 (19.7)	4,420 (19.7)	4,420 (19.7)	4,420 (19.7)
		M20	lb (kN)	- -	5,425 (24.1)	5,425 (24.1)	5,425 (24.1)
Strength reduction factor for failure of connection between channel lips and channel bolts ¹ (periodic inspection)	ϕ	M12	-	0.55			
		M16					
		M20					
Strength reduction factor for failure of connection between channel lips and channel bolts ¹ (continuous inspection)	ϕ	M12	-	0.55			
		M16					
		M20		0.65			

¹The tabulated value of ϕ applies when the load combinations of Section 1605.1 of the 2024 IBC or ACI 318-19 Section 5.3 are used.

²In case of continuous inspection the value for $V_{sl,x}$ for the size M12 can be taken for all channel sizes HAC-40F through HAC-70F as $V_{sl,x} = 2,021$ lb (9.0 kN).

TABLE 8-12—STEEL STRENGTH DESIGN INFORMATION FOR SHEAR ACTING IN LONGITUDINAL DIRECTION OF THE CHANNEL AXIS FOR HILTI ANCHOR CHANNELS (HAC-V) WITH HILTI CHANNEL BOLTS (HBC-C-N)

Criteria	Symbol	Bolt type HBC-C-N	Units	Anchor channel sizes				
				HAC-V 35	HAC-V 40	HAC-V 50 (Rebar XTS)	HAC-V 60	HAC-V 70 (Rebar XTS)
Nominal shear steel strength of connection between channel lips and channel bolts	$V_{sl,x}$	M12 ²	lb (kN)	1,920 (8.5)	1,920 (8.5)	1,920 (8.5)	1,920 (8.5)	1,920 (8.5)
		M16	lb (kN)	4,420 (19.7)	4,420 (19.7)	4,420 (19.7)	4,420 (19.7)	4,420 (19.7)
		M20	lb (kN)	- -	- -	5,425 (24.1)	5,425 (24.1)	5,425 (24.1)
Nominal shear steel strength of connection between channel lips and channel bolts for seismic design	$V_{sl,x,seis}$	M12 ²	lb (kN)	1,920 (8.5)	1,920 (8.5)	1,920 (8.5)	1,920 (8.5)	1,920 (8.5)
		M16	lb (kN)	4,420 (19.7)	4,420 (19.7)	4,420 (19.7)	4,420 (19.7)	4,420 (19.7)
		M20	lb (kN)	- -	- -	5,425 (24.1)	5,425 (24.1)	5,425 (24.1)
Strength reduction factor for failure of connection between channel lips and channel bolts ¹ (periodic inspection)	ϕ	M12	-	0.55				
		M16						
		M20						
Strength reduction factor for failure of connection between channel lips and channel bolts ¹ (continuous inspection)	ϕ	M12	-	0.55				
		M16						
		M20		0.65				

¹The tabulated value of ϕ applies when the load combinations of Section 1605.1 of the 2024 IBC or ACI 318-19 Section 5.3 are used.

²In case of continuous inspection the value for $V_{sl,x}$ for the size M12 can be taken for all channel sizes HAC-V 40F through HAC-V 70F as $V_{sl,x} = 2,021$ lb (9.0 kN).

TABLE 8-13—STEEL STRENGTH DESIGN INFORMATION FOR SHEAR ACTING IN LONGITUDINAL DIRECTION OF THE CHANNEL AXIS FOR HILTI ANCHOR CHANNELS (HAC) WITH HILTI CHANNEL BOLTS (HBC-C) IN COMBINATION WITH HIT HY-100 ADHESIVE

Criteria	Symbol	Units	Anchor channel sizes			
			HAC-40	HAC-50	HAC-60	HAC-70
Nominal shear steel strength of connection between channel lips and channel bolts	$V_{sl,x}$	lb (kN)	- -	7,460 (33.2)	7,460 (33.2)	9,630 (42.8)
Nominal shear steel strength of connection between channel lips and channel bolts for seismic design	$V_{sl,x,seis}$	lb (kN)	- -	7,460 (33.2)	7,460 (33.2)	9,630 (42.8)
Strength reduction factor for failure of connection between channel lips and channel bolts ¹ for periodic and continuous inspection	ϕ	-	-	0.75		

¹The tabulated value of ϕ applies when the load combinations of Section 1605.1 of the 2024 IBC or ACI 318-19 Section 5.3 are used.

TABLE 8-14—STEEL STRENGTH DESIGN INFORMATION FOR SHEAR ACTING IN LONGITUDINAL DIRECTION OF THE CHANNEL AXIS FOR HILTI ANCHOR CHANNELS (HAC-V) WITH HILTI CHANNEL BOLTS (HBC-C) IN COMBINATION WITH HIT HY-100 ADHESIVE

Criteria	Symbol	Units	Anchor channel sizes				
			HAC-V 35	HAC-V 40	HAC-V 50 (Rebar XTS)	HAC-V 60	HAC-V 70 (Rebar XTS)
Nominal shear steel strength of connection between channel lips and channel bolts	$V_{sl,x}$	lb (kN)	- -	- -	7,460 (33.2)	7,460 (33.2)	9,630 (42.8)
Nominal shear steel strength of connection between channel lips and channel bolts for seismic design	$V_{sl,x,seis}$	lb (kN)	- -	- -	7,460 (33.2)	7,460 (33.2)	9,630 (42.8)
Strength reduction factor for failure of connection between channel lips and channel bolts ¹ for periodic and continuous inspection	ϕ	-	-	-	0.75		

¹The tabulated value of ϕ applies when the load combinations of Section 1605.1 of the 2024 IBC or ACI 318-19 Section 5.3 are used.

TABLE 8-15—SHEAR CONCRETE STRENGTH DESIGN INFORMATION FOR HILTI ANCHOR CHANNELS (HAC AND HAC-T) WITH HILTI CHANNEL BOLTS (HBC-B, HBC-C, HBC-C-N, AND HBC-T)

Criteria	Symbol	Units	Anchor channel sizes				
			HAC-30	HAC-40	HAC-50 HAC-T50	HAC-60	HAC-70 HAC-T70
Factor to account for the influence of channel size and anchor diameter on concrete edge breakout strength in shear	$\alpha_{ch,v}$	lb ^{1/2} /in ^{1/3} (N ^{1/2} /mm ^{1/3})	10.5 (7.5)				
Coefficient for pryout strength	k_{cp}	-	2.0				
Strength reduction factor for shear, concrete failure modes ¹	ϕ	-	0.70				

¹The tabulated value of ϕ applies when both the load combinations of Section 1605.1 of the 2024 IBC or ACI 318-19 Section 5.3 are used and the requirements of ACI 318-19 Table 17.5.3(b) for supplementary reinforcement not present are met. For installations where complying supplementary reinforcement can be verified, the ϕ factors described in ACI 318-19 Table 17.5.3(b) are allowed.

TABLE 8-16—SHEAR CONCRETE STRENGTH DESIGN INFORMATION FOR HILTI ANCHOR CHANNELS (HAC-V AND HAC-V-T) WITH HILTI CHANNEL BOLTS (HBC-B, HBC-C, HBC-C-N, AND HBC-T)

Criteria	Symbol	Units	Anchor channel sizes				
			HAC-V-T 30	HAC-V 35 HAC-V 40	HAC-V 50 (Rebar XTS) HAC-V-T 50 (Rebar XTS)	HAC-V 60	HAC-V 70 (Rebar XTS) HAC-V-T 70 (Rebar XTS)
Factor to account for the influence of channel size and anchor diameter on concrete edge breakout strength in shear	$\alpha_{ch,V}$	lb ^{1/2} /in ^{1/3} (N ^{1/2} /mm ^{1/3})	10.5 ² (7.5) ²				
Coefficient for pryout strength	k_{cp}	-	2.0				
Strength reduction factor for shear, concrete failure modes ¹	ϕ	-	0.70				

¹The tabulated value of ϕ applies when both the load combinations of Section 1605.1 of the 2024 IBC or ACI 318-19 Section 5.3 are used and the requirements of ACI 318-19 Table 17.5.3(b) for supplementary reinforcement not present are met. For installations where complying supplementary reinforcement can be verified, the ϕ factors described in ACI 318-19 Table 17.5.3(b) are allowed.

²The value $\alpha_{ch,V}$ should be reduced to 10.4 lb^{1/2}/in^{1/3} respectively 7.4 (N^{1/2}/mm^{1/3}) in case of Rebar XTS

TABLE 8-17—TENSION STEEL STRENGTH DESIGN INFORMATION FOR HILTI CHANNEL BOLTS (HBC-B, HBC-C, HBC-C-N, AND HBC-T)

Criteria	Symbol	Bolt type	Units	Channel bolt sizes			
				M10	M12	M16	M20
Nominal tensile strength of a channel bolt	N_{ss}	HBC-B 4.6	lb (kN)	5,215 (23.2)	7,575 (33.7)	- -	- -
		HBC-C 4.6	lb (kN)	- -	- -	14,115 (62.8)	- -
		HBC-C 50R	lb (kN)	- -	- -	14,080 (62.6)	- -
		HBC-C 8.8	lb (kN)	- -	15,160 (67.4)	28,235 (125.6)	39,190 (174.3)
		HBC-T 8.8	lb (kN)	- -	15,160 (67.4)	28,235 (125.6)	39,229 (174.5)
		HBC-C-N 8.8	lb (kN)	- -	15,160 (67.4)	28,235 (125.6)	45,524 (202.5)
Nominal tensile strength of a channel bolt for seismic design	$N_{ss,seis}$	HBC-B 4.6	lb (kN)	- -	7,575 (33.7)	- -	- -
		HBC-C 8.8	lb (kN)	- -	15,160 (67.4)	28,235 (125.6)	39,190 (174.3)
		HBC-T 8.8	lb (kN)	- -	15,160 (67.4)	28,235 (125.6)	39,229 (174.5)
		HBC-C-N 8.8	lb (kN)	- -	15,160 (67.4)	28,235 (125.6)	45,524 (202.5)
Strength reduction factor for tension, steel failure modes ¹	ϕ	-	-	0.65			

¹The tabulated value of ϕ applies when the load combinations of Section 1605.1 of the 2024 IBC or ACI 318-19 Section 5.3 are used.

TABLE 8-18—SHEAR STEEL STRENGTH DESIGN INFORMATION FOR HILTI CHANNEL BOLTS (HBC-B, HBC-C, HBC-C-N, AND HBC-T)

Criteria	Symbol	Bolt type	Units	Channel bolt sizes			
				M10	M12	M16	M20
Nominal shear strength of a channel bolt	V_{ss}	HBC-B 4.6	lb (kN)	3,125 (13.9)	4,540 (20.2)	- -	- -
		HBC-C 4.6	lb (kN)	- -	- -	8,470 (37.6)	- -
		HBC-C 50R	lb (kN)	- -	- -	8,450 (37.5)	- -
		HBC-C(-N) and HBC-T 8.8	lb (kN)	- -	9,095 (40.4)	16,940 (75.3)	27,427 (122.0)
Nominal shear strength of a channel bolt for seismic design	$V_{ss,seis}$	HBC-B 4.6	lb (kN)	- -	4,540 (20.2)	- -	- -
		HBC-C(-N) and HBC-T 8.8	lb (kN)	- -	9,095 (40.4)	16,940 (75.3)	27,427 (122.0)
Nominal flexural strength of the channel bolt	M_{ss}^0	HBC-B 4.6	lb (kN)	265 (29.9)	465 (52.4)	- -	- -
		HBC-C 4.6	lb-in (Nm)	- -	- -	1,180 (133.1)	- -
		HBC-C 50R	lb-in (Nm)	- -	- -	1,180 (132.8)	- -
		HBC-C(-N) and HBC-T 8.8	lb-in (Nm)	- -	930 (104.8)	2,355 (266.3)	4,768 (538.7)
Nominal flexural strength of the channel bolt for seismic design	$M_{ss,seis}^0$	HBC-B 4.6	lb-in (Nm)	- -	465 (52.4)	- -	- -
		HBC-C(-N) and HBC-T 8.8	lb-in (Nm)	- -	930 (104.8)	2,355 (266.3)	4,768 (538.7)
Strength reduction factor for shear, steel failure modes ¹	ϕ	-	-	0.60			

¹The tabulated value of ϕ applies when the load combinations of Section 1605.1 of the 2024 IBC ACI 318-19 Section 5.3 are used.

TABLE 8-19—MATERIAL SPECIFICATIONS AND PROPERTIES FOR HILTI ANCHOR CHANNELS (HAC(-V) AND HAC(-V)-T) AND HILTI CHANNEL BOLTS (HBC-B, HBC-C, HBC-C-N, AND HBC-T)

Component	Carbon steel	Surface	Stainless steel
Channel Profile	Carbon steel	Hot dip galvanized (F) ≥ 55 μm ¹ Hot dip galvanized (F) ≥ 70 μm ²	-
Rivet		Hot dip galvanized (F) ≥ 45 μm	-
Anchor		Hot dip galvanized (F) ≥ 45 μm	-
Deformed reinforcing bar	Low-alloy steel according to ASTM A706 or carbon steel according to DIN 488-BSt 500		
Channel bolt	Grade 4.6 and 8.8 according to DIN EN ISO 898-1:2009-8	Hot dip galvanized (F) ≥ 45 μm, or electroplated (G) ≥ 8 μm	Grade 50 according to DIN EN ISO 3506-1:2010-4, passivation according ASTM A380
Plain washer ³ ISO 7089 and ISO 7093-1	Hardness A, 200 HV	Hot dip galvanized (F), or electroplated (G)	Hardness A, 200 HV according to ISO 3506-1
Hexagonal nut ISO 4032 or DIN 934 ⁴	Property class 8 according to ISO 898-2, or property class 5 according to DIN 267-4	Hot dip galvanized (F) ≥ 45 μm, or electroplated (G) ≥ 8 μm	Property class 70 according to DIN 267-11

¹For HAC(-V-T) 30F, HAC(-V) 35F, HAC(-V) 40F and HAC(-V)(-T) 50F

²For HAC(-V) 60F and HAC(-V)(-T) 70F

³Not in scope of delivery

⁴Hexagonal nuts DIN 934 for channel bolts made from carbon steel grade 4.6 and stainless steel bolts

TABLE 9— APPLICABLE SECTIONS OF THE IBC UNDER EACH EDITION OF THE IBC

2024 IBC	2021 IBC	2018 IBC	2015 IBC
Section 1605.1		Section 1605.2 or 1605.3	
Section 1705.1.1 and Table 1705.3			
Section 1901.3			
Sections 1903 and 1905			

TABLE 10— APPLICABLE SECTIONS OF ACI 318 UNDER EACH EDITION OF THE IBC

2024 IBC	2021 IBC	2018 IBC	2015 IBC
ACI 318-19		ACI 318-14	
5.3		5.3	
Chapter 17		Chapter 17	
17.5.1.2		17.3.1	
Table 17.5.2		Table 17.3.1.1	
17.5.3		17.3.3	
Table 17.5.3(b)		17.3.3	
Eq 17.6.2.7b*		Eq 17.4.2.10b*	
17.6.3.1		17.4.3.1	
17.6.3.2		17.4.3.4	
17.6.3.3		17.4.3.6	
17.7.2.1		17.5.2.1	
17.7.2.2		17.5.2.2	
17.10		17.2.3	
17.10.5.2		17.2.3.4.2	
17.10.5.3 (b), (c) or (d)		17.2.3.4.3 (b), (c) or (d)	
17.10.6.2		17.2.3.5.2	
17.10.6.3		17.2.3.5.3	
24.3.2		24.3.2	
24.3.3		24.3.3	
Chapter 25		Chapter 25	
25.5		25.5	

*ACI section based on AC232 as referenced in Section 6.1 of this report.



HAC-(V)-(T)

CE
11
HILTI AG
FL-9494 Schaan
Hilti Werke
2873-CPR-201-18/07, 14
ETA-11/0006
Notified body 2873
EAD330008-03-0601
Anchor channels for fixing
to concrete
www.hilti.group

ICC
ES[®]
ESR-3520

2015302-07.2021

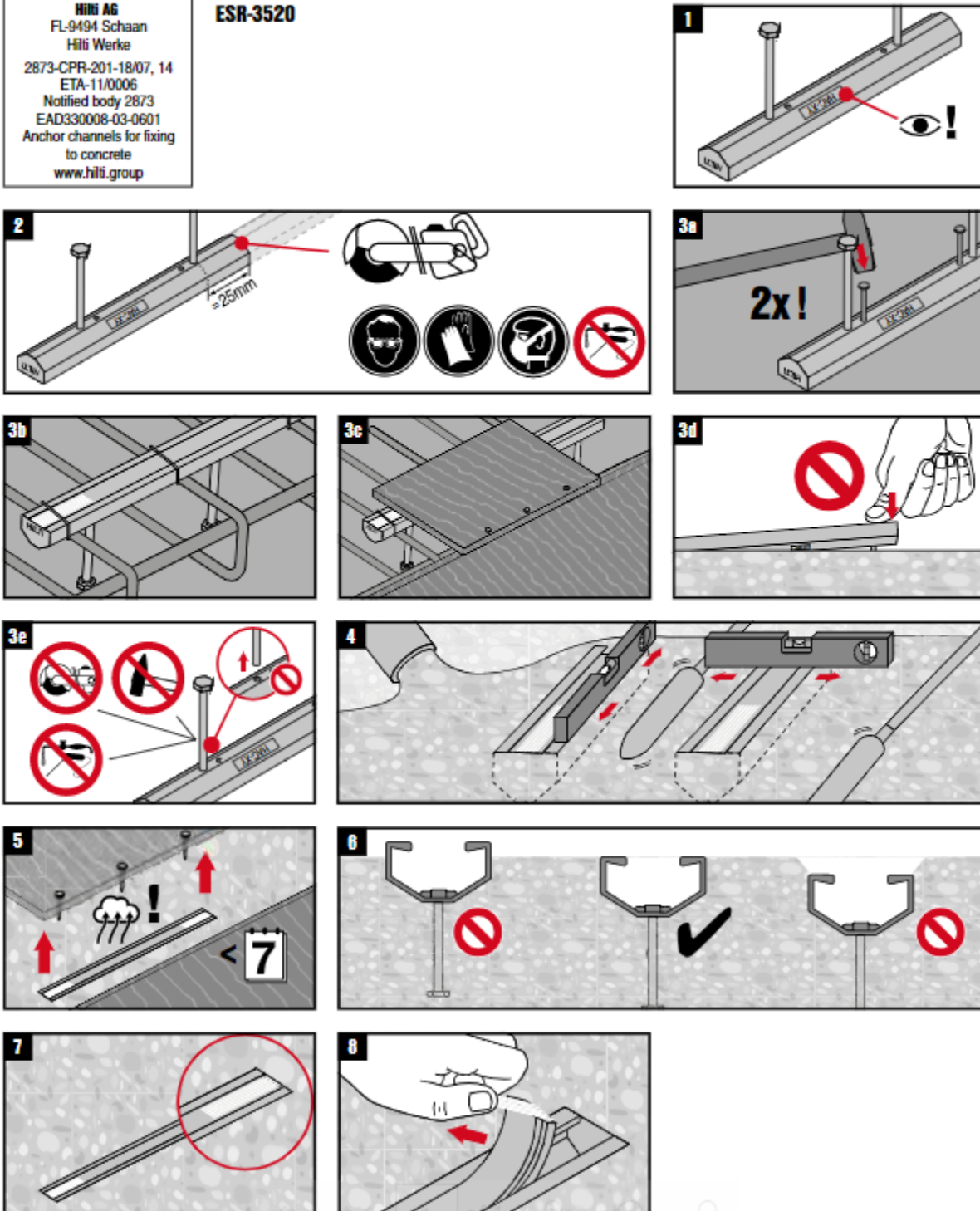

FIGURE 8-6: MANUFACTURER'S PRINTED INSTALLATION INSTRUCTIONS (MPII) FOR HILTI ANCHOR CHANNELS (HAC-(V) AND HAC-(V)-T)



HAC-V XTS HAC-V-T XTS

2151600-02.2022

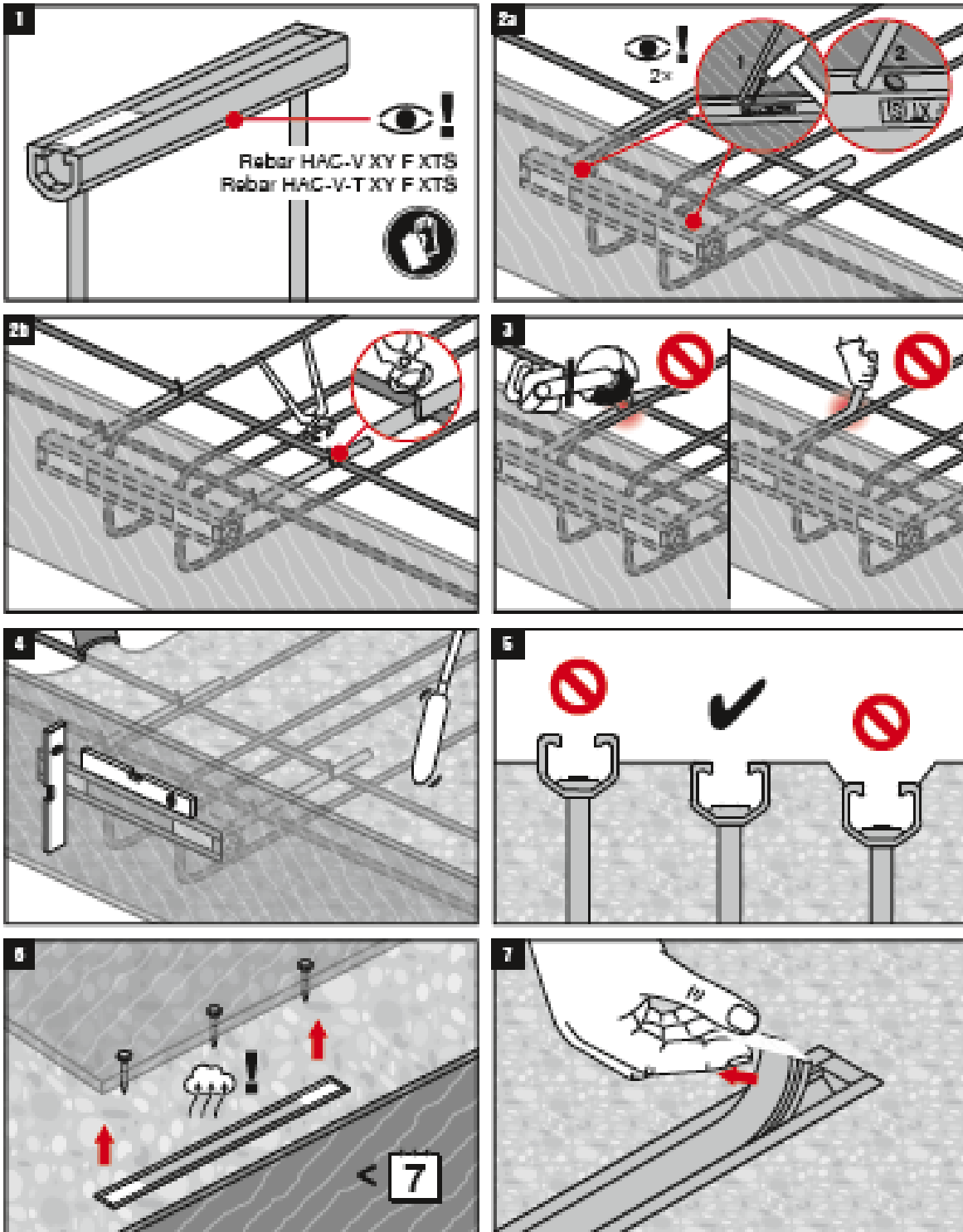

FIGURE 8-7: MANUFACTURER'S PRINTED INSTALLATION INSTRUCTIONS (MPII) FOR HILTI ANCHOR CHANNELS (HAC-V REBAR XTS AND HAC-V-T REBAR XTS)



HBC-B

2214763-06.2023

1

 HBC-B 4.6 HBC-B A4-50	 HAC(-V-T) 30
------------------------------	------------------

2

3

4

5

6

A

6

B

7

AT-System

		T _{inst}				
		 HAC(-V-T)-30	 HAC(-V-T)-30	SIW 6AT-A22 + SI-AT-A22	SIW 4AT-22 + SI-AT-22	SIW 6AT-22 + SI-AT-22
M10	4.6, A4-50	15 Nm / 11 ft-lb	15 Nm / 11 ft-lb	✓	✓	✗
M12	4.6, A4-50	25 Nm / 19 ft-lb	25 Nm / 19 ft-lb	✓	✓	✗

FIGURE 8-8: MANUFACTURER'S PRINTED INSTALLATION INSTRUCTIONS (MPII) FOR HILTI CHANNELS BOLTS (HBC-B)



HBC-C

437419-06.2023

	HBC-C 4.6	HAC(-V)-35 to HAC(-V)-70
	HBC-C 8.8	HAC(-V)-50 to HAC(-V)-70 XT/XTS
	HBC-C A4-50	HAC(-V)-40 to HAC(-V)-70 CRFoS
	HBC-C-E 8.8	HAC(-V)-40, -50 EDGE (Lite)

--	--	--	--

--

--

		T_{inst}						
		HAC(-V)-35 HAC(-V)-40	HAC(-V)-50	HAC(-V)-60 HAC(-V)-70	HAC(-V)-35 to HAC(-V)-70	SIW 6AT-A22 + SI-AT-A22	SIW 4AT-22 + SI-AT-22	SIW 6AT-22 + SI-AT-22
M10	4.6, A4-50	15 Nm / 11 ft-lb			15 Nm / 11 ft-lb	✓	✓	✗
	8.8	15 Nm / 11 ft-lb			48 Nm / 35 ft-lb	✓	✓	✗
M12	4.6, A4-50	25 Nm / 19 ft-lb			25 Nm / 19 ft-lb	✓	✓	✓
	8.8	25 Nm / 19 ft-lb			75 Nm / 55 ft-lb	✓	✓	✓
M16	4.6, A4-50	60 Nm / 44 ft-lb			60 Nm / 44 ft-lb	✓	✓	✓
	8.8	60 Nm / 44 ft-lb			185 Nm / 136 ft-lb	✓	✓	✓
M20	4.6, A4-50	70 Nm / 52 ft-lb	105 Nm / 78 ft-lb	120 Nm / 89 ft-lb	120 Nm / 89 ft-lb	✓	✓	✓
	8.8	70 Nm / 52 ft-lb	105 Nm / 78 ft-lb	120 Nm / 89 ft-lb	320 Nm / 236 ft-lb	✓	✓	✓

FIGURE 8-9: MANUFACTURER'S PRINTED INSTALLATION INSTRUCTIONS (MPI) FOR HILTI CHANNEL BOLTS (HBC-C)



2155164-06.2023

HBC-T 8.8F	HAC(-V)-T50, -T70 HAC(-V)-T50, -T70 XT/XTS HAC(-V)-T50, -T70 CRFoS HAC(-V)-T50 EDGE (Lite)

	T _{inst}				
	HAC(-V)-T50 HAC(-V)-T70	HAC(-V)-T50 HAC(-V)-T70	SIW 6AT-A22 + SI-AT-A22	SIW 4AT-22 + SI-AT-22	SIW 6AT-22 + SI-AT-22
M12	75 Nm / 55 ft-lb	75 Nm / 55 ft-lb	✓	✓	✓
M16	100 Nm / 74 ft-lb	185 Nm / 136 ft-lb	✓	✓	✓
M20	120 Nm / 89 ft-lb	320 Nm / 236 ft-lb	✗	✗	✓

FIGURE 8-10: MANUFACTURER'S PRINTED INSTALLATION INSTRUCTIONS (MPII) FOR HILTI CHANNELS BOLTS (HBC-T)



HBC-C-N

2138453-06.2023

1

HBC-C-N 8.8	HAC(-V)-35 to HAC(-V)-70 HAC(-V)-50 to HAC(-V)-70 XT/XTS HAC(-V)-40 to HAC(-V)-70 CRFoS HAC(-V)-40 to HAC(-V)-50 EDGE (Lite)

2

3

4

5

6

A

B

7

	T_{inst}				
			SIW 6AT-A22 + SI-AT-A22	SIW 4AT-22 + SI-AT-22	SIW 6AT-22 + SI-AT-22
M12	HAC(-V)-35 HAC(-V)-40	HAC(-V)-50 / 60 / 70	75 Nm / 55 ft-lb	75 Nm / 55 ft-lb	75 Nm / 55 ft-lb
M16	185 Nm / 136 ft-lb	185 Nm / 136 ft-lb	✓	✓	✓
M20	-	320 Nm / 236 ft-lb	✗	✗	✗

FIGURE 8-11: MANUFACTURER'S PRINTED INSTALLATION INSTRUCTIONS (MPII) FOR HILTI CHANNELS BOLTS (HBC-C-N)



HBC-C
with Hilti HIT-HY 100

2151943 A2-07.2016

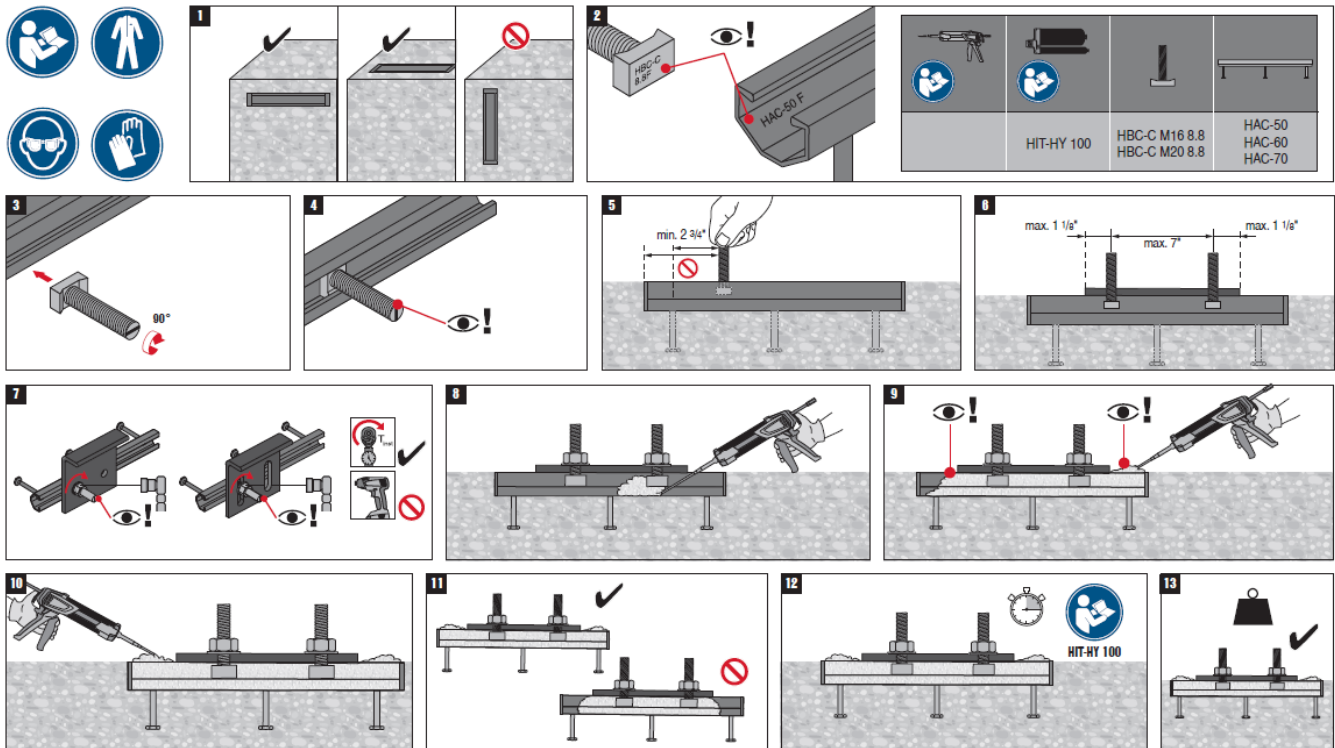

FIGURE 8-12: MANUFACTURER'S PRINTED INSTALLATION INSTRUCTIONS (MPII) FOR HILTI ANCHOR CHANNELS (HAC) WITH HILTI CHANNEL BOLTS (HBC-C) USED IN CONJUNCTION WITH HILTI HIT-HY-100 ADHESIVE

DIVISION: 03 00 00—CONCRETE

Section: 03 15 19—Cast-In Concrete Anchors

Section: 03 16 00—Concrete Anchors

REPORT HOLDER:

HILTI, INC.

EVALUATION SUBJECT:

HILTI ANCHOR CHANNEL SYSTEMS: HILTI ANCHOR CHANNELS HAC(-V) WITH HILTI CHANNEL BOLTS HBC-B, HBC-C AND HBC-C-N AND HILTI ANCHOR CHANNELS HAC(-V)-T WITH HILTI CHANNEL BOLTS HBC-T IN CRACKED AND UNCRACKED CONCRETE

1.0 REPORT PURPOSE AND SCOPE

Purpose:

The purpose of this evaluation report supplement is to indicate that the Hilti anchor channel systems: Hilti anchor channels HAC(-V) with Hilti channel bolts HBC-B (serrated channel bolts), HBC-C and HBC-C-N (locking channel bolts) and Hilti anchor channels HAC-T with Hilti channel bolts HBC(-V)-T (serrated channel bolts) in cracked and uncracked concrete, described in ICC-ES evaluation report [ESR-3520](#), have also been evaluated for compliance with the codes noted below as adopted by the Los Angeles Department of Building and Safety (LADBS).

Applicable code editions:

- 2023 *City of Los Angeles Building Code* ([LABC](#))
- 2023 *City of Los Angeles Residential Code* ([LARC](#))

2.0 CONCLUSIONS

The Hilti anchor channel systems: Hilti anchor channels HAC(-V) with Hilti channel bolts HBC-B, HBC-C and HBC-C-N and Hilti anchor channels HAC(-V)-T with Hilti channel bolts HBC-T in cracked and uncracked concrete, described in Sections 2.0 through 7.0 of the evaluation report [ESR-3520](#), comply with the LABC Chapter 19, and the LARC, and are subjected to the conditions of use described in this supplement.

3.0 CONDITIONS OF USE

The Hilti anchor channel systems: Hilti anchor channels HAC(-V) with Hilti channel bolts HBC-B, HBC-C and HBC-C-N and Hilti anchor channels HAC(-V)-T with Hilti channel bolts HBC-T in cracked and uncracked concrete described in this evaluation report supplement must comply with all of the following conditions:

- All applicable sections in the evaluation report [ESR-3520](#).
- The design, installation, conditions of use and identification of the Hilti anchor channel systems are in accordance with the 2021 *International Building Code*® (IBC) and 2021 *International Residential Code*® (IRC) provisions, as applicable, noted in the evaluation report [ESR-3520](#).
- The design, installation and inspection are in accordance with additional requirements of LABC Chapters 16, 17 and 19, as applicable.
- Under the LARC, an engineered design in accordance with LARC Section R301.1.3 must be submitted.
- The allowable stress and strength design values listed in the evaluation report and tables are for the connection of the Hilti anchor channel systems to the concrete. The connection between the Hilti anchor channel systems and the connected members shall be checked for capacity (which may govern).

This supplement expires concurrently with the evaluation report, reissued August 2025 and revised November 2025.

DIVISION: 03 00 00—CONCRETE
Section: 03 15 19—Cast-In Concrete Anchors
Section: 03 16 00—Concrete Anchors

REPORT HOLDER:

HILTI, INC.

EVALUATION SUBJECT:

HILTI ANCHOR CHANNEL SYSTEMS: HILTI ANCHOR CHANNELS HAC(-V) WITH HILTI CHANNEL BOLTS HBC-B, HBC-C AND HBC-C-N AND HILTI ANCHOR CHANNELS HAC(-V)-T WITH HILTI CHANNEL BOLTS HBC-T IN CRACKED AND UNCRACKED CONCRETE

1.0 REPORT PURPOSE AND SCOPE

Purpose:

The purpose of this evaluation report supplement is to indicate that the Hilti anchor channel systems: Hilti anchor channels HAC(-V) with Hilti channel bolts HBC-B (serrated channel bolts), HBC-C and HBC-C-N (locking channel bolts) and Hilti anchor channels HAC(-V)-T with Hilti channel bolts HBC-T (serrated channel bolts) in cracked and uncracked concrete, described in ICC-ES evaluation report [ESR-3520](#), has also been evaluated for compliance with the codes noted below.

Applicable code editions:

- 2023 Florida Building Code—Building
- 2023 Florida Building Code—Residential

2.0 CONCLUSIONS

The Hilti anchor channel systems: Hilti anchor channels HAC(-V) with Hilti channel bolts HBC-B, HBC-C and HBC-C-N and Hilti anchor channels HAC(-V)-T with Hilti channel bolts HBC-T in cracked and uncracked concrete, described in Sections 2.0 through 7.0 of the evaluation report [ESR-3520](#), comply with the *Florida Building Code—Building* and the *Florida Building Code—Residential*. The design requirements must be determined in accordance with the *Florida Building Code—Building* or the *Florida Building Code—Residential*, as applicable. The installation requirements noted in ICC-ES evaluation report [ESR-3520](#) for the 2021 *International Building Code*® meet the requirements of the *Florida Building Code—Building* or the *Florida Building Code—Residential*, as applicable.

Use of the Hilti anchor channel systems has also been found to be in compliance with the High-Velocity Hurricane Zone provisions of the *Florida Building Code—Building* and the *Florida Building Code—Residential* with the following condition:

- a.) For anchorage of wood members, the connection subject to uplift must be designed for no less than 700 pounds (3114 N) in accordance with item 3 of Section 2321.7 of the *Florida Building Code—Building*.

For products falling under Florida Rule 61G20-3, verification that the report holder's quality assurance program is audited by a quality assurance entity approved by the Florida Building Commission for the type of inspections being conducted is the responsibility of an approved validation entity (or the code official when the report holder does not possess an approval by the Commission). Florida Rule 61G20-3 is applicable to products and/or systems which comprise the building envelope and structural frame for compliance with the structural requirements of the Florida Building Code.

This supplement expires concurrently with the evaluation report, reissued August 2025 and revised November 2025.