

# ICC-ES Evaluation Report

**ESR-1546**

Reissued March 2026

Revised April 2026

Subject to renewal March 2028

This report also contains:

- [City of LA Supplement](#)

- [FL Supplement](#)

ICC-ES Evaluation Reports are not to be construed as representing aesthetics or any other attributes not specifically addressed, nor are they to be construed as an endorsement of the subject of the report or a recommendation for its use. There is no warranty by ICC Evaluation Service, LLC, express or implied, as to any finding or other matter in this report, or as to any product covered by the report.

Copyright © 2026 ICC Evaluation Service, LLC. All rights reserved.

<p><b>DIVISION: 03 00 00— CONCRETE</b></p> <p><b>Section: 03 16 00— Concrete Anchors</b></p> <p><b>DIVISION: 05 00 00— METALS</b></p> <p><b>Section: 05 05 19—Post- Installed Concrete Anchors</b></p>	<p><b>REPORT HOLDER:</b> <b>HILTI, INC.</b></p>	<p><b>EVALUATION SUBJECT:</b> <b>HILTI HDA CARBON STEEL AND STAINLESS-STEEL UNDERCUT ANCHORS FOR CRACKED AND UNCRAKED CONCRETE</b></p>	
--	---	--	---

## 1.0 EVALUATION SCOPE

### Compliance with the following codes:

- 2024, 2021, 2018, and 2015 [International Building Code® \(IBC\)](#)
- 2024, 2021, 2018, and 2015 [International Residential Code® \(IRC\)](#)

Main references of this report are for the 2024 IBC and IRC. See [Table 7](#) and [Table 8](#) for applicable sections of the code for previous IBC and IRC editions.

### Property evaluated:

- Structural

## 2.0 USES

The Hilti HDA Undercut Anchor is used to resist static, wind, and seismic tension and shear loads in cracked and uncracked normal-weight and lightweight concrete having a specified compressive strength,  $f'_c$ , of 2,500 psi to 8,500 psi (17.2 MPa to 58.6 MPa). The anchoring system complies with anchors as described in Section 1901.3 of the 2024 IBC. The anchoring system is an alternative to cast-in-place anchors described in Section 1901.3 of the 2024 IBC. The anchors may also be used where an engineered design is submitted in accordance with Section R301.1.3 of the IRC.

## 3.0 DESCRIPTION

### 3.1 HDA:

The Hilti HDA Carbon Steel and Stainless Steel Undercut Anchors, designated as the HDA and HDA-R, respectively, are self-undercutting undercut anchors. The HDA and HDA-R are each comprised of six components as shown in [Figures 1](#) and [2](#) of this report. The HDA and HDA-R are available in pre-set (HDA-P and HDA-PR) and through-set (HDA-T and HDA-TR) configurations as illustrated in [Figures 1](#) and [2](#) of this report.

All carbon steel parts receive a minimum 0.0002-inch-thick (5  $\mu$ m) galvanized zinc coating equivalent to ASTM B633, Type I. The HDA-R is fabricated from stainless steel with corrosion resistance equivalent to AISI 316 or AISI 316Ti. Dimensions and installation criteria are set forth in [Tables 1](#) through [4](#) of this report. This

anchor is manufactured using metric units. Strength design information is provided in [Tables 5](#) and [6](#) of this report.

### 3.2 Carbon Steel HDA:

**3.2.1 Cone Bolt:** The cone bolt for the M10 through M16 sizes is cold-formed from carbon steel. The cone bolt for the M20 size is machined from carbon steel. The cone bolt is equipped on one end with rolled threads terminating in a dog-point. A parabolic cone is formed on the other end. A gap is provided in the thread for a painted red setting mark (used for visual setting control). This mark becomes visible only when complete installation of the anchor has been achieved. As packaged, the dog-point end of the rod is equipped with a removable clear plastic cap to protect the thread during the setting process. An alphabetic length code as listed in [Table 1](#) of this report is stamped and/or printed on the end of the rod to permit determination of the nominal embedment depth of the installed anchor. To prevent disassembly and possible improper installation of the anchor, the cone bolt is locked into the sleeve by means of an indentation in the sleeve.

**3.2.2 Sleeve:** The sleeve is machined from precision steel tubing. At the installed end of the anchor, the sleeve is equipped with six hinged bearing elements in a radial array. Two diametrically opposed elements are equipped with brazed tungsten carbide tips to facilitate the undercutting process during setting of the anchor. In the fully installed position, the bearing elements rest on the parabolic curve of the cone and bear on a form-fit undercut in the concrete. The opposite end of the sleeve is equipped with two D-shaped slots to engage the setting tool.

**3.2.3 Washer:** The M10 through M16 sizes are equipped with spring washers. The M20 size is equipped with a washer fabricated from galvanized carbon steel.

**3.2.4 Hex Nut:** The M10 through M20 sizes are equipped with a hexagonal nut formed from galvanized carbon steel conforming to DIN 934.

**3.2.5 Plastic Retention Ring:** The expansion sleeve is equipped with a red plastic ring stamped with the name HILTI. The ring nests in the recess provided in the sleeve at the terminus of the expansion sections. It prevents displacement of the concrete into the recess at ultimate load levels.

### 3.3 Stainless Steel HDA-R:

**3.3.1 Cone Bolt:** The anchor rod and cone bolt are machined from stainless steel. The geometry and function are as described in Section 3.2.1. The cone bolt is equipped with a clear plastic cap as described in Section 3.2.1 of this report.

**3.3.2 Sleeve:** The sleeve is machined from solid bar stock stainless steel or precision steel tubing. The geometry and function are as described in Section 3.2.2 of this report.

**3.3.3 Washer:** The spring washer is fabricated from stainless steel.

**3.3.4 Hex Nut:** The hex nut is fabricated from stainless steel.

**3.3.5 Plastic Retention Ring:** As described in Section 3.2.5 of this report, but the color of the retention ring is black.

### 3.4 Concrete:

Normal-weight and lightweight concrete must conform to Sections 1903 and 1905 of the IBC.

## 4.0 DESIGN AND INSTALLATION

### 4.1 Strength Design:

**4.1.1 General:** Design strength of anchors complying with the 2024 IBC, as well as Section R301.1.3 of the 2024 IRC must be determined in accordance with ACI 318-19 Chapter 17 and this report.

Design parameters provided in [Tables 5](#) and [6](#) and references to ACI 318 are based on the 2024 IBC (ACI 318-19), unless noted otherwise in Sections 4.1.1 through 4.1.12 of this report. The strength design of anchors must comply with ACI 318-19 Section 17.5.1.2, except as required in ACI 318-19 Section 17.10. Strength reduction factors,  $\phi$ , as given in ACI 318-19 Section 17.5.3 must be used for load combinations calculated in accordance with Section 1605.1 of the 2024 IBC and Section 5.3 of ACI 318-19.

The value of  $f'_c$  used in the calculations must be limited to 8,000 psi (55.2 MPa), maximum, in accordance with ACI 318-19 Section 17.3.1.

**4.1.2 Requirements for Static Steel Strength in Tension:** The nominal static steel strength,  $N_{sa}$ , of a single anchor in tension calculated in accordance with ACI 318-19 Section 17.6.1.2, is given in [Table 5](#) of this report. Strength reduction factors,  $\phi$ , corresponding to ductile steel elements may be used.

**4.1.3 Requirements for Static Concrete Breakout Strength in Tension:** The nominal static concrete breakout strength of a single anchor or group of anchors in tension,  $N_{cb}$  or  $N_{cbg}$ , respectively, must be calculated

in accordance with ACI 318-19 Section 17.6.2, with modifications as described in this section. The basic concrete breakout strength,  $N_b$ , must be calculated in accordance with ACI 318-19 Section 17.6.2.2, using the values of  $h_{ef}$  and  $k_{cr}$  as given in [Table 5](#) of this report. The nominal concrete breakout strength in tension in regions where analysis indicates no cracking in accordance with ACI 318-19 Section 17.6.2.5, must be calculated with  $k_{uncr}$  as given in [Table 5](#) with  $\Psi_{c,N} = 1.0$ .

**4.1.4 Requirements for Static Pullout Strength in Tension:** In cracked and uncracked concrete, pullout failure does not control and therefore need not be evaluated.

**4.1.5 Requirements for Static Steel Strength in Shear  $V_{sa}$ :** The nominal steel strength in shear,  $V_{sa}$ , of a single anchor in accordance with ACI 318-19 Section 17.7.1.2, is given in [Table 5](#) and [Table 6](#), and must be used in lieu of the values derived by calculation from ACI 318-19 Eq. 17.7.1.2(b). The strength reduction factor,  $\phi$ , corresponding to ductile steel elements may be used.

**4.1.6 Requirements for Static Concrete Breakout Strength in Shear,  $V_{cb}$  or  $V_{cbg}$ :** The nominal concrete breakout strength of a single anchor or group of anchors in shear,  $V_{cb}$  or  $V_{cbg}$ , respectively, must be calculated in accordance with ACI 318-19 Section 17.7.2, with modifications as described in this section. The basic concrete breakout strength in shear,  $V_b$ , must be calculated in accordance with ACI 318-19 Section 17.7.2.2.1, using the value of  $l_e$  and  $d_a$  given in [Table 5](#). In no case shall  $l_e$  be taken as greater than  $8d_a$  in the calculation of  $V_{cb}$  or  $V_{cbg}$ .

**4.1.7 Requirements for Static Concrete Pryout Strength in Shear,  $V_{cp}$  or  $V_{cpg}$ :** The nominal concrete pryout strength of a single anchor or group of anchors,  $V_{cp}$  or  $V_{cpg}$ , respectively, must be calculated in accordance with ACI 318-19 Section 17.7.3, modified by using the value of  $k_{cp}$  provided in [Table 5](#) and the value of  $N_{cb}$  or  $N_{cbg}$  as calculated in Section 4.1.3 of this report.

**4.1.8 Requirements for Seismic Design:** For load combinations including seismic, the design must be performed in accordance with ACI 318-19 Section 17.10. Modifications to ACI 318-19 Section 17.10 shall be applied under Section 1905.7 of the IBC.

The nominal steel strength, the nominal concrete breakout strength and the nominal pullout strength for anchors in tension and the nominal concrete breakout strength and pryout strength for anchors in shear are the same for seismic and static loading. They must be calculated in accordance with ACI 318-19 Sections 17.6 and 17.7, for tension and shear, respectively, taking into account the corresponding values given in [Table 5](#) of this report. The nominal steel strength for seismic loads,  $V_{sa,eq}$ , for anchors in shear must be taken from [Tables 5](#) and [6](#) of this report.

**4.1.9 Requirements for Interaction of Tensile and Shear Forces:** The effects of combined tensile and shear forces must be determined in accordance with ACI 318-19 Section 17.8.

**4.1.10 Requirements for Minimum Member Thickness, Minimum Anchor Spacing and Minimum Edge Distance:** In lieu of ACI 318-19 Section 17.9.2, values of  $s_{min}$  and  $c_{min}$ , respectively, as given in [Table 5](#) of this report must be used. In lieu of ACI 318-19 Section 17.9.4, minimum member thicknesses  $h_{min}$  as given in [Tables 3A](#) and [3B](#) of this report must be used.

**4.1.11 Requirements for Critical Edge Distance,  $c_{ac}$ :** In lieu of ACI 318-19 Section 17.6.2.6, the modification factor,  $\Psi_{cp,N}$ , shall be taken as 1.0 for all cases. In accordance with ACI 318-19 Section 17.9.5, tension tests in accordance with ACI 355.2 have determined splitting failure under external load does not govern the resistance of the HDA, i.e.  $c_{ac} = 1.5h_{ef}$ . Therefore, no values for the critical edge distance  $c_{ac}$  are provided since this calculation is not required for design.

**4.1.12 Lightweight Concrete:** For the use of anchors in lightweight concrete, the modification factor  $\lambda_a$  equal to  $1.0\lambda$  is applied to all values of  $\sqrt{f'_c}$  affecting  $N_n$  and  $V_n$ .

The value  $\lambda$  shall be determined in accordance with the corresponding version of ACI 318.

## 4.2 Allowable Stress Design (ASD):

**4.2.1 General:** Design values for use with allowable stress design (working stress design) load combinations calculated in accordance with Section 1605.1 of the IBC, must be established using Eq-2 and Eq-3:

$$T_{allowable,ASD} = \frac{\phi N_n}{\alpha} \quad (\text{Eq-2})$$

$$V_{allowable,ASD} = \frac{\phi V_n}{\alpha} \quad (\text{Eq-3})$$

where:

$$T_{allowable, ASD} = \text{Allowable tension load (lbf or kN)}$$

$V_{allowable, ASD}$  = Allowable shear load (lbf or kN)

$\phi N_n$  = Lowest design strength of an anchor or anchor group in tension as determined in accordance with ACI 318-19 Chapter 17, 2024 IBC Section 1905.7 and Section 4.1 of this report, as applicable (lbf or N).

$\phi V_n$  = Lowest design strength of an anchor or anchor group in shear as determined in accordance with ACI 318-19 Chapter 17, 2024 IBC Section 1905.7 and Section 4.1 of this report, as applicable (lbf or N).

$\alpha$  = Conversion factor calculated as a weighted average of the load factors for the controlling load combination. In addition,  $\alpha$  shall include all applicable factors to account for nonductile failure modes and required over-strength.

Limits on edge distance, anchor spacing and member thickness as given in this report must apply.

**4.2.2 Interaction of Tensile and Shear Forces:** The interaction must be calculated and consistent with ACI 318-19 Section 17.8 as follows:

For shear loads  $V_{applied} \leq 0.2V_{allowable, ASD}$ , the full allowable load in tension  $T_{allowable, ASD}$  shall be permitted.

For tension loads  $T_{applied} \leq 0.2T_{allowable, ASD}$ , the full allowable load in shear  $V_{allowable, ASD}$  shall be permitted.

For all other cases:

$$\frac{T_{applied}}{T_{allowable, ASD}} + \frac{V_{applied}}{V_{allowable, ASD}} \leq 1.2 \quad (\text{Eq-4})$$

### 4.3 Installation:

Installation parameters are provided in [Tables 1](#) through [4](#) of this report and in [Figures 1](#) through [3](#) of this report. Anchors must be installed per the manufacturer's instructions. (See [Figures 5](#) through [8](#) of this report.) Anchor locations must comply with this report and the plans and specifications approved by the code official. Required stop drill bits and setting tools as indicated in [Tables 4B](#), [4C](#) and [Figure 4](#) are provided by the manufacturer. Required hammer drill specifications are provided in [Table 4A](#) of this report.

### 4.4 Special Inspection:

Special inspection is required in accordance with Section 1705.1.1 and Table 1705.3 of the IBC. The special inspector must make periodic inspections during anchor installation to verify anchor type, anchor dimensions, concrete type, concrete compressive strength, hole dimensions, hole cleaning procedures, anchor spacing, edge distances, concrete thickness, anchor embedment, tightening torque and adherence to the manufacturer's published installation instructions. The special inspector must be present as often as required in accordance with the "statement of special inspection." Additional requirements as set forth in Sections 1705, 1706 and 1707 of the IBC must be observed, where applicable.

## 5.0 CONDITIONS OF USE:

The Hilti HDA and HDA-R anchors described in this report comply with, or are suitable alternatives to what is specified in, those codes listed in Section 1.0 of this report, subject to the following conditions:

- 5.1 Anchor sizes, dimensions and minimum embedment depths are as set forth in the tables of this report.
- 5.2 The anchors must be installed in accordance with the manufacturer's published installation instructions and this report. In case of conflict, this report governs.
- 5.3 Anchors must be limited to use in concrete with a specified strength of  $f'_c = 2,500$  psi to 8,500 psi (17.2 to 58.6 MPa).
- 5.4 The values of  $f'_c$  used for calculation purposes must not exceed 8,000 psi (55.2 MPa).
- 5.5 Loads applied to the anchors are adjusted in accordance with Section 1605.1 of the 2024 IBC for strength design and allowable stress design.
- 5.6 Strength design values are established in accordance with Section 4.1 of this report.
- 5.7 Allowable design values are established in accordance with Section 4.2 of this report.
- 5.8 Anchor spacing(s) and edge distance(s) as well as minimum member thickness comply with [Tables 3A](#), [3B](#) and [5](#) of this report.
- 5.9 Prior to installation, calculations and details demonstrating compliance with this report must be submitted to the code official for approval. The calculations and details must be prepared by a registered design professional where required by the statutes of the jurisdiction in which the project is to be constructed.

- 5.10 Since an ICC-ES acceptance criteria for evaluating data to determine the performance of anchors subjected to fatigue or shock loading is unavailable at this time, the use of these anchors under such conditions is beyond the scope of this report.
- 5.11 Anchors may be installed in regions of concrete where cracking has occurred or where analysis indicates cracking may occur ( $f_t > f_r$ ), subject to the conditions of this report.
- 5.12 Anchors may be used to resist short-term loading due to wind or seismic forces, subject to the conditions of this report.
- 5.13 Where not otherwise prohibited in the code, anchors are permitted for use with fire-resistance-rated construction provided that at least one of the following conditions is fulfilled:
- Anchors are used to resist wind or seismic forces only.
  - Anchors that support a fire-resistance-rated envelope or a fire-resistance-rated membrane are protected by approved fire-resistance-rated materials, or have been evaluated for resistance to fire exposure in accordance with recognized standards.
  - Anchors are used to support nonstructural elements.
- 5.14 Use of zinc-coated carbon steel anchors is limited to dry, interior locations.
- 5.15 Special inspection must be provided in accordance with Section 4.4 of this report.
- 5.16 Anchors are manufactured under an approved quality control program with inspections by ICC-ES.

## 6.0 EVIDENCE SUBMITTED

Data in accordance with the [ICC-ES Acceptance Criteria for Mechanical Anchors in Concrete Elements AC193 \(24\)](#), dated April 2025 and quality control documentation.

## 7.0 IDENTIFICATION

- 7.1 The ICC-ES mark of conformity, electronic labeling, or the evaluation report number (ICC-ES ESR-1546) along with the name, registered trademark, or registered logo of the report holder must be included in the product label.
- 7.2 In addition, the anchors are identified by packaging labeled with the manufacturer's name (Hilti, Inc.) and address, anchor name, and anchor size. The anchors have the anchor designation printed on the sleeve.
- 7.3 The report holder's contact information is the following:

**HILTI, INC.**  
**7250 DALLAS PARKWAY, SUITE 1000**  
**PLANO, TEXAS 75024**  
**(800) 879-8000**  
[www.hilti.com](http://www.hilti.com)

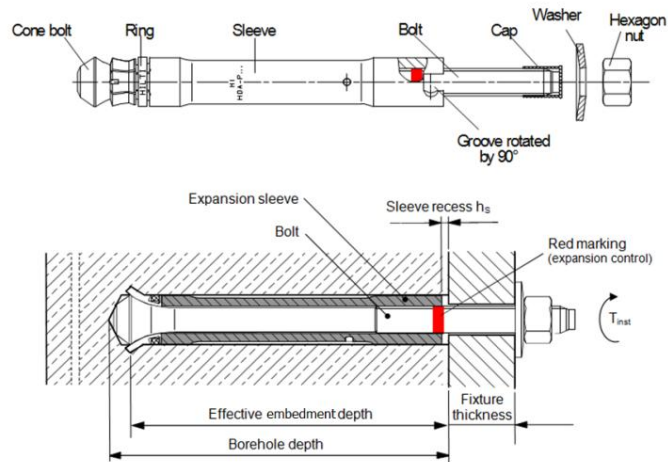

FIGURE 1—PRE-SETTING ANCHOR HDA-P AND HDA-PR (PRE-POSITIONING)

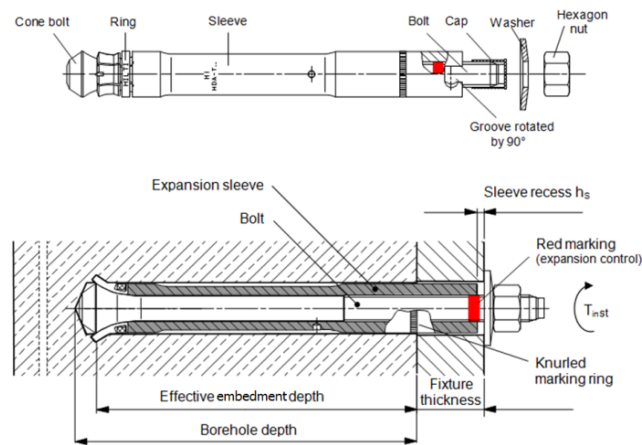

FIGURE 2—THROUGH-FASTENING ANCHOR HDA-T AND HDA-TR (POST-POSITIONING)

TABLE 1—ANCHOR DIMENSIONAL CHARACTERISTICS (mm)

Anchor type	t <sub>fix</sub> <sup>1</sup> [mm] min-max	l <sub>B</sub> [mm]	Length code letter	l <sub>S</sub> [mm]	l <sub>k</sub> [mm]	SW	d <sub>S1</sub> [mm]	d <sub>S2</sub> [mm]	d <sub>S3</sub> [mm]	d <sub>C</sub> [mm]	d <sub>B</sub> [mm]
HDA-P(R) M10x100/20	0-20	150	I	100	-	17	19	16.8	18.5	19.5	10
HDA-T(R) M10x100/20	10-20	150	I	120	17	17	19	16.8	18.5	19.5	10
HDA-P(R) M12x125/30	0-30	190	L	125	-	19	21	18.8	20.5	21.4	12
HDA-P(R) M12x125/50	0-50	210	N	125	-	19	21	18.8	20.5	21.4	12
HDA-T(R) M12x125/30	10-30	190	L	155	27	19	21	18.8	20.5	21.4	12
HDA-T(R) M12x125/50	10-50	210	N	175	47	19	21	18.8	20.5	21.4	12
HDA-P(R) M16x190/40	0-40	275	R	190	-	24	29	26	29	29	16
HDA-P(R) M16x190/60	0-60	295	S	190	-	24	29	26	29	29	16
HDA-T(R) M16x190/40	15-40	275	R	230	35.5	24	29	26	29	29	16
HDA-T(R) M16x190/60	15-60	295	S	250	35.5	24	29	26	29	29	16
HDA-P M20x250/50	0- 50	360	V	250	-	30	35	32	35	36	20
HDA-P M20x250/100	0-100	410	X	250	-	30	35	32	35	36	20
HDA-TM20x250/50	20-50	360	V	300	45	30	35	32	35	36	20
HDA-T M20x250/100	50-100	410	X	350	95	30	35	32	35	36	20

For in-lb units: 1 mm = 0.03937 inches

<sup>1</sup>first value: t<sub>fix,min</sub> minimum fixture thickness for pure tension load (shear load see Table 6), second value: t<sub>fix,max</sub> maximum fixture thickness.

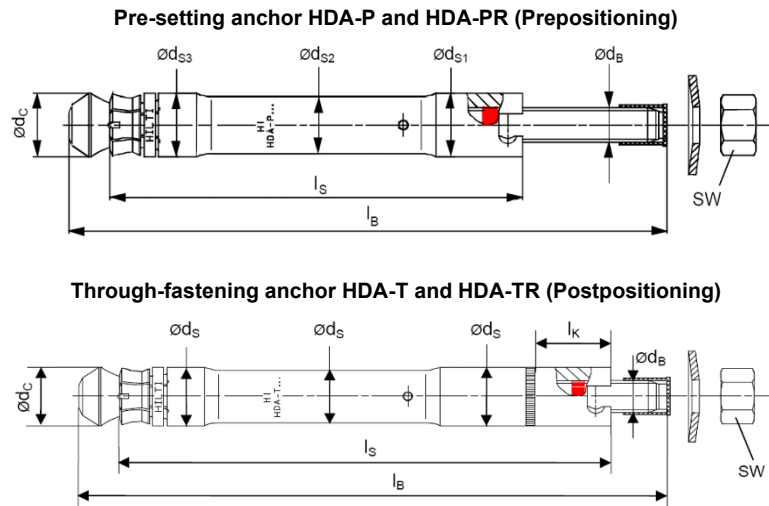

FIGURE 3—HDA DIMENSIONS

TABLE 2—CHARACTERISTIC VALUES OF ANCHORS AND INSTALLATION<sup>1,2,3</sup>

HDA M10 to M20 and HDA-R M10 to M16			M10		M12		M16		M20	
			P	T	P	T	P	T	P	T
Nominal drill bit diameter <sup>1</sup>	$d_{bit}$	mm	20	20	22	22	30	30	37	37
Minimum hole depth <sup>1,2</sup>	$h_{hole}$	mm (in.)	107 (4.21)	107 (4.21)	133 (5.30)	133 (5.30)	203 (7.99)	203 (7.99)	266 (10.47)	266 (10.47)
Maximum clearance hole diameter in fastened part	$d_h$	mm (in.)	12 (0.47)	21 (0.83)	14 (0.55)	23 (0.91)	18 (0.71)	32 (1.26)	22 (0.87)	40 (1.57)
Min. thickness of fastened part	$t_{min}$	mm (in.)	0 0	10 (0.39)	0 0	10 (0.39)	0 0	15 (0.59)	0 0	20 (0.79)
Sleeve recess <sup>3</sup>	$h_s$	mm	$2 \leq h_s \leq 6$		$2 \leq h_s \leq 7$		$2 \leq h_s \leq 8$		$2 \leq h_s \leq 8$	
		(in.)	$(0.08 \leq h_s \leq 0.24)$		$(0.08 \leq h_s \leq 0.28)$		$(0.08 \leq h_s \leq 0.31)$		$(0.08 \leq h_s \leq 0.31)$	
Installation torque	$T_{inst}$	Nm	50	50	80	80	120	120	300	300
		(ft-lb)	(37)	(37)	(59)	(59)	(89)	(89)	(221)	(221)

For in-lb units: 1mm = 0.03937 inches, 1 Nm = 0.7376 ft-lb

<sup>1</sup>Use required stop drill bits only. See Table 4b and 4c

<sup>2</sup>Actual hole depth for HDA-T is provided by minimum hole depth + ( $t_{fix,max} - t_{fix}$ ) where  $t_{fix,max}$  is provided in Table 3B and  $t_{fix}$  is the thickness of the part(s) being fastened.

<sup>3</sup>Sleeve recess after setting of the anchor:

- a) Pre-setting anchor HDA-P(R): distance from surface of the concrete member to top edge of the anchor sleeve (see Figure 1)
- b) Through-fastening anchor HDA-T(R): distance from top edge of the fixture to top edge of the anchor sleeve (see Figure 2)

TABLE 3A—MINIMUM THICKNESS OF CONCRETE MEMBER, HDA-P AND HDA-PR

Anchor type			HDA-P M10 HDA-PR M10	HDA-P M12 HDA-PR M12	HDA-P M16 HDA-PR M16	HDA-P M20
Minimum thickness of concrete member	$h_{min}$	mm (in.)	180 (7.1)	200 (7.9)	270 <sup>1</sup> (10.6)	350 (13.8)

For in units: 1mm = 0.03937 inches

<sup>1</sup>With TE 70  $h_{min} \geq 300$ mm (11.8 in) for HDA-P(PR) M16.

TABLE 3B—MINIMUM THICKNESS OF CONCRETE MEMBER, HDA-T AND HDA-TR<sup>1</sup>

Anchor type			HDA-T M10 HDA-TR M10	HDA-T M12 HDA-TR M12		HDA-T M16 HDA-TR M16		HDA-T M20	
Maximum fastenable thickness	$t_{fix,max}$	mm	20	30	50	40	60	50	100
Minimum thickness of concrete member <sup>1</sup>	$h_{min}$	mm (in.)	200- $t_{fix}$ (7.9- $t_{fix}$ )	230- $t_{fix}$ (9.1- $t_{fix}$ )	250- $t_{fix}$ (9.8- $t_{fix}$ )	310- $t_{fix}^2$ (12.2- $t_{fix}$ )	330- $t_{fix}^2$ (13.0- $t_{fix}$ )	400- $t_{fix}$ (15.7- $t_{fix}$ )	450- $t_{fix}$ (17.7- $t_{fix}$ )

For in units: 1mm = 0.03937 inches

<sup>1</sup> $h_{min}$  is dependent on the actual fixture thickness  $t_{fix}$  (use of a stop drill bit) e.g. HDA-T M12\*125/50 :  $t_{fix} = 20$ mm  $\rightarrow h_{min} = 250-20 = 230$ mm  
 $t_{fix} = 50$ mm  $\rightarrow h_{min} = 250-50 = 200$ mm.

<sup>2</sup>With TE 70  $h_{min} = 340$ mm -  $t_{fix}$  for  $t_{fix,max} = 40$ mm and  $h_{min} = 360$ mm -  $t_{fix}$  for  $t_{fix,max} = 60$ mm when using HDA-T(TR) M16.

**TABLE 4A—REQUIRED HAMMER DRILLS FOR SETTING**

Hilti hammer drill bit connection type	M10 and M12	M16	M20
	Tool (Gen.)	Tool (Gen.)	Tool (Gen.)
TE-C connection (SDS Plus)	TE 30-22 (03)	-	-
	TE 30 (02)	-	-
TE-Y connection (SDS Max)	TE 50 (03)	TE 60-22 (04)	TE 70 (03)
	TE 60-22 (04)	TE 60 (04)	TE 70 (04)
	TE 60 (04)	TE 70 (03) <sup>1</sup>	-
	-	TE 70 (04) <sup>1</sup>	-

For all tools always use max hammering power.

<sup>1</sup>Increase  $h_{min}$  for the TE 70 with the HDA M16. See [Table 3A](#) and [3B](#).

**TABLE 4B—REQUIRED STOP DRILL BIT AND SETTING TOOL**

Anchor type	Stop drill bit	Setting tool
HDA-P(R) M10x100/20	TE-C-HDA-B 20x100 or TE-Y-HDA-B 20x100	TE-C-HDA-ST M10 or TE-Y-HDA-ST M10
HDA-T(R) M10x100/20	TE-C-HDA-B 20x120 or TE-Y-HDA-B 20x120	
HDA-P(R) M12x125/30	TE-C-HDA-B 22x125 or TE-Y-HDA-B 22x125	TE-C-HDA-ST M12 or TE-Y-HDA-ST M12
HDA-P(R) M12x125/50		
HDA-T(R) M12x125/30	TE-C-HDA-B 22x155 or TE-Y-HDA-B 22x155	
HDA-T(R) M12x125/50	TE-C-HDA-B 22x175 or TE-Y-HDA-B 22x175	
HDA-P(R) M16x190/40	TE-Y-HDA-B 30x190	TE-Y-HDA-ST M16
HDA-P(R) M16x190/60		
HDA-T(R) M16x190/40	TE-Y-HDA-B 30x230	
HDA-T(R) M16x190/60	TE-Y-HDA-B 30x250	
HDA-P M20x250/50	TE-Y-HDA-B 37x250	TE-Y-HDA-ST M20
HDA-P M20x250/100		
HDA-T M20x250/50	TE-Y-HDA-B 37x300	
HDA-T M20x250/100	TE-Y-HDA-B 37x350	

TABLE 4C—STOP DRILL BIT DIMENSIONS

Stop drill bit TE-C/Y-HDA-B $d_0 \times l_s$	Working length $t$ [mm]	Marking Hilti C/Y $d_a$ -HDA $l_s$ (K)		
		Connection end TE-	Nominal drilling diameter $d_a$ [mm]	HDA $l_s$ (K)
TE-C-HDA-B 20x100	107	C	20	HDA 100
TE-Y-HDA-B 20x100	107	Y	20	HDA 100
TE-C-HDA-B 20x120	127	C	20	HDA 120
TE-Y-HDA-B 20x120	127	Y	20	HDA 120
TE-Y-HDA-B 20x180	187	Y	20	HDA 180
TE-C-HDA-B 22x125	133	C	22	HDA 125 K
TE-Y-HDA-B 22x125	133	Y	22	HDA 125 K
TE-C-HDA-B 22x155	163	C	22	HDA 155 K
TE-Y-HDA-B 22x155	163	Y	22	HDA 155 K
TE-C-HDA-B 22x175	183	C	22	HDA 175 K
TE-Y-HDA-B 22x175	183	Y	22	HDA 175 K
TE-Y-HDA-B 22x215	223	Y	22	HDA 215 K
TE-Y-HDA-B 30x190	203	Y	30	HDA 190
TE-Y-HDA-B 30x230	243	Y	30	HDA 230
TE-Y-HDA-B 30x250	263	Y	30	HDA 250
TE-Y-HDA-B 30x290	303	Y	30	HDA 290
TE-Y-HDA-B 30x310	323	Y	30	HDA 310
TE-Y-HDA-B 37x250	266	Y	37	HDA 250
TE-Y-HDA-B 37x300	316	Y	37	HDA 300
TE-Y-HDA-B 37x350	366	Y	37	HDA 350

For in units: 1mm = 0.03937 inches

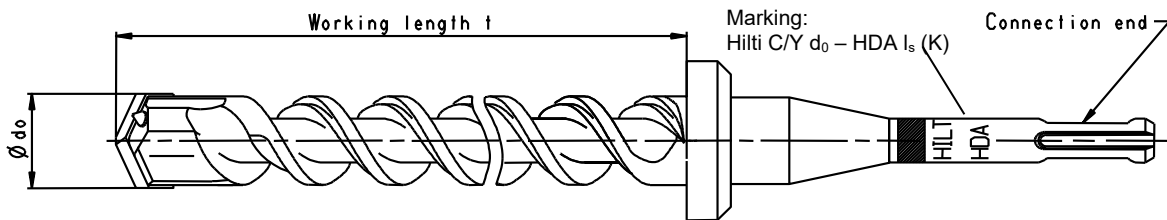

FIGURE 4—HILTI STOP DRILL BIT DIMENSIONS AND IDENTIFICATION

1	Drill a hole to the required depth using a stop drill bit matched to the anchor. Refer to <a href="#">TABLE 4B</a> of this report.
2	Remove the drilling debris from the hole using a vacuum, compressed air or a hand air pump.
3	The anchor is placed to the bottom of the hole by hand. Do not strike with a hammer. Do not remove the plastic cap. This cap protects the threading during installation.
4	Select the HDA setting tool specified in <a href="#">TABLE 4B</a> of this report. Insert into hammer drill specified in <a href="#">TABLE 4A</a> of this report. Hammer drill models and brands may not be substituted.
5	The anchor is set with the hammer drill operating in hammer and drilling mode. The drilling and impact energy are transferred from the setting tool to the anchor sleeve. The sleeve is driven over the conical end of the cone bolt forming the undercut. The red ring on the setting tool indicates the progress of the setting operation. See pictogram 5.
6	The operator should observe the red ring on the anchor rod advance above the anchor sleeve. The anchor is set and the undercut is fully formed when the measurement of the recess from the top of the sleeve to the concrete surface, $h_s$ , is within the tolerance specified in <a href="#">TABLE 2</a> of this report.
7	Remove the plastic cap and place the fixture.
8	Secure the fixture with the nut and washer. Tighten nut with a torque wrench. The installation torque shall not exceed those specified in <a href="#">TABLE 2</a> of this report.

FIGURE 5—GENERAL INSTALLATION INSTRUCTIONS FOR HDA-P AND HDA-PR ANCHORS IN FIGURE 6

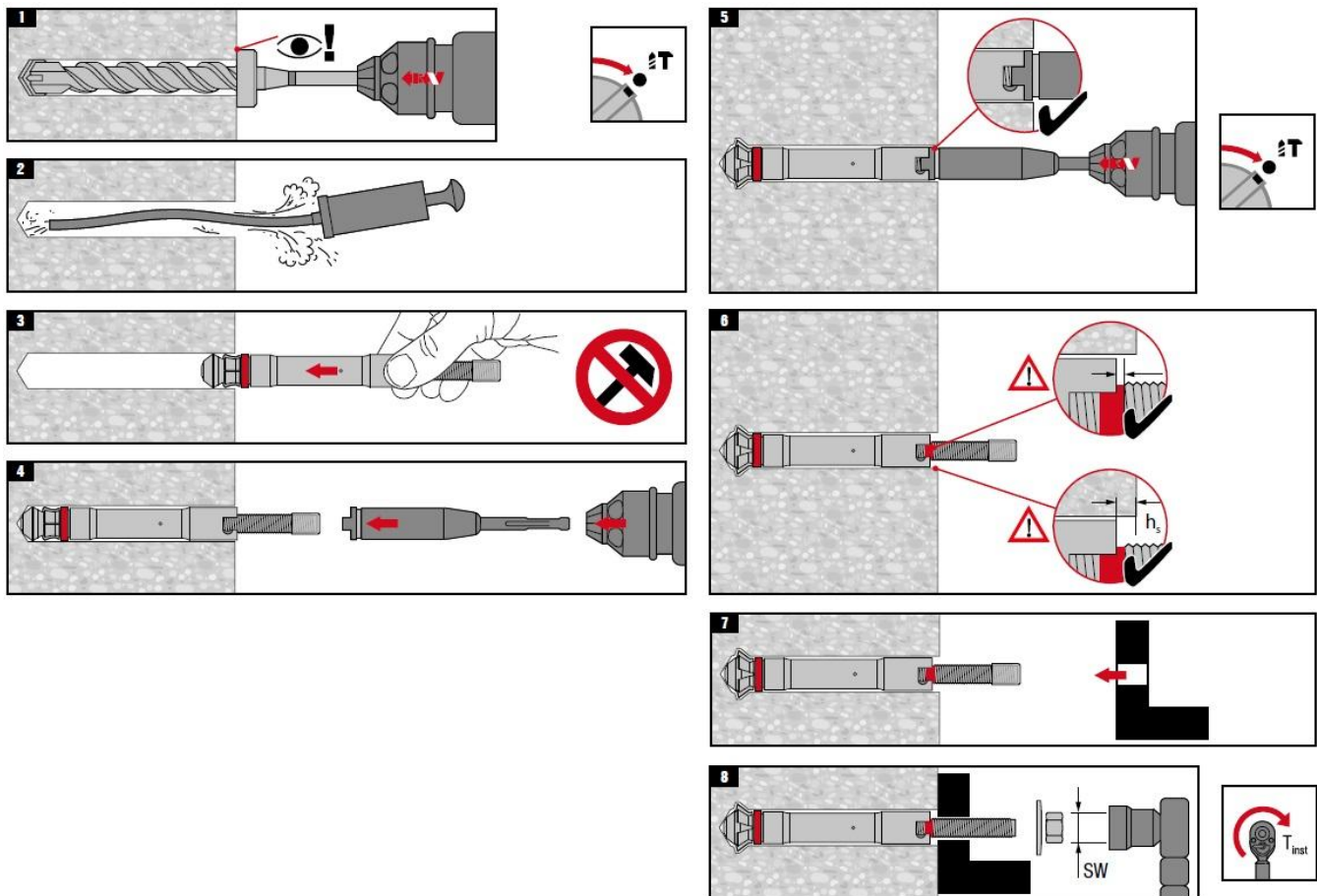

FIGURE 6—INSTALLATION INSTRUCTIONS FOR HDA-P AND HDA-PR ANCHORS

1	Drill a hole to the required depth using a stop drill bit matched to the anchor. Refer to <a href="#">TABLE 4B</a> of this report. Position fixture so that the fixture bears fully on the concrete surface without a gap between the fixture and concrete, and so that the fixture hole is centered over the drilled hole in the concrete.
2	Remove the drilling debris from the hole using a vacuum, compressed air or a hand air pump.
3	The anchor is placed to the bottom of the hole by hand. Do not strike with a hammer. Do not remove the plastic cap. This cap protects the threading during installation.
4	Select the HDA setting tool specified in <a href="#">TABLE 4B</a> of this report. Insert into hammer drill specified in <a href="#">TABLE 4A</a> of this report. Hammer drill models and brands may not be substituted.
5	The anchor is set with the hammer drill operating in hammer and drilling mode. The drilling and impact energy are transferred from the setting tool to the anchor sleeve. The sleeve is driven over the conical end of the cone bolt forming the undercut. The red ring on the setting tool indicates the progress of the setting operation. See pictogram 5.
6	The operator should observe the red ring on the anchor rod advance above the anchor sleeve. The anchor is set and the undercut is fully formed when the measurement of the recess from the top of the sleeve to the fixture surface, $h_s$ , is within the tolerance specified in <a href="#">TABLE 2</a> of this report.
7	Remove the plastic cap. Secure the fixture with the nut and washer. Tighten nut with a torque wrench. The installation torque shall not exceed those specified in <a href="#">TABLE 2</a> of this report.

FIGURE 7— GENERAL INSTALLATION INSTRUCTIONS FOR HDA-T AND HDA-TR ANCHORS IN FIGURE 8

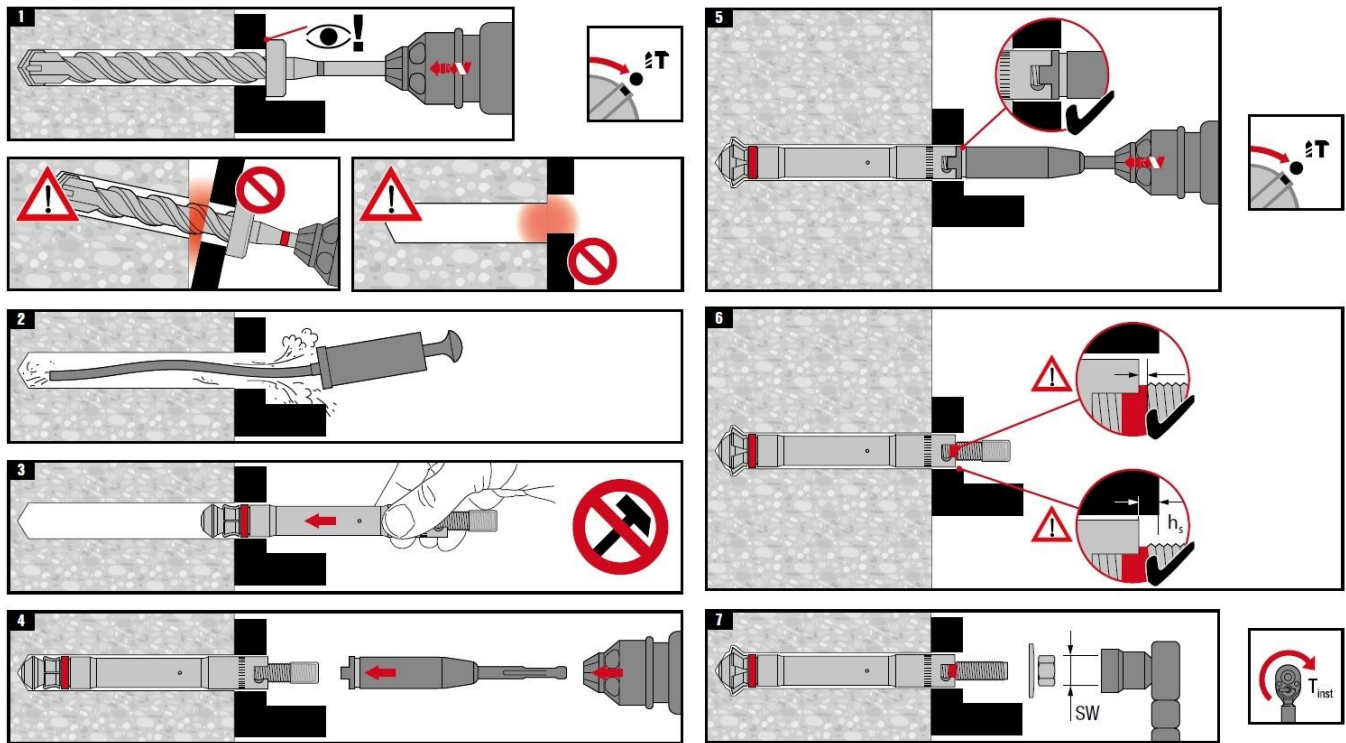

FIGURE 8—INSTALLATION INSTRUCTIONS FOR HDA-T AND HDA-TR ANCHORS

TABLE 5—DESIGN INFORMATION, HILTI HDA UNDERCUT ANCHORS

Design Parameter	Symbol	Units	Nominal anchor diameter						
			M10		M12		M16		M20
			HDA	HDA-R	HDA	HDA-R	HDA	HDA-R	HDA
Anchor O.D.	$d_a$	mm (in.)	19 (0.75)		21 (0.83)		29 (1.14)		35 (1.38)
Effective minimum embedment depth <sup>1</sup>	$h_{ef,min}$ $l_e^{10}$	mm (in.)	100 (3.94)		125 (4.92)		190 (7.48)		250 (9.84)
Minimum edge distance	$c_{min}$	mm (in.)	80 (3 <sup>-1</sup> / <sub>8</sub> )		90 (3 <sup>-1</sup> / <sub>2</sub> )		120 (4 <sup>-3</sup> / <sub>4</sub> )		150 (6)
Minimum anchor spacing	$s_{min}$	mm (in.)	80 (3 <sup>-1</sup> / <sub>8</sub> )		90 (3 <sup>-1</sup> / <sub>2</sub> )		120 (4 <sup>-3</sup> / <sub>4</sub> )		150 (6)
Critical edge distance <sup>9</sup>	$c_{ac}$	-	See Section 4.1.11 of this report						
Minimum thickness of concrete member	$h_{min}$	-	See Tables 3A and 3B						
Anchor category <sup>2</sup>	1, 2 or 3	-	1	1	1	1	1	1	1
Strength reduction factor for tension, steel failure modes <sup>3</sup>	$\phi$	-	0.75						
Strength reduction factor for shear, steel failure modes <sup>3</sup>	$\phi$	-	0.65						
Strength reduction factor for tension, concrete failure modes <sup>3</sup>	$\phi$	Cond. A	0.75						
		Cond. B	0.65						
Strength reduction factor for shear, concrete failure modes <sup>3</sup>	$\phi$	Cond. A	0.75						
		Cond. B	0.70						
Yield strength of anchor carbon steel	$f_{ya}$	lb/in <sup>2</sup> (N/mm <sup>2</sup> )	92,800 (640)						
Yield strength of anchor stainless steel	$f_{ya}$	lb/in <sup>2</sup> (N/mm <sup>2</sup> )	87,000 (600)						
Ultimate strength of anchor carbon and stainless steel	$f_{uta}$	lb/in <sup>2</sup> (N/mm <sup>2</sup> )	116,000 (800)						
Tensile stress area	$A_{se}$	in <sup>2</sup> (mm <sup>2</sup> )	0.090 (58.1)		0.131 (84.5)		0.243 (156.8)		0.380 (235.2)
Steel strength in tension	$N_{sa}$	lb (kN)	10,440 (46.4)		15,196 (67.6)		28,188 (125.4)		44,080 (196.1)
Effectiveness factor uncracked concrete	$k_{unscr}$	-	30	30	30	30	30	30	30
Effectiveness factor cracked concrete <sup>4</sup>	$k_{cr}$	-	24	24	24	24	24	24	24
$k_{unscr}/k_{cr}$ <sup>5</sup>	$\psi_{c,N}$	-	1.00	1.00	1.00	1.00	1.00	1.00	1.00
Pullout strength cracked concrete <sup>6</sup>	$N_{p,cr}$	-	N/A	N/A	N/A	N/A	N/A	N/A	N/A
Coefficient for pryout	$k_{cp}$	-	2.00	2.00	2.00	2.00	2.00	2.00	2.00
Steel strength in shear static <sup>7</sup> HDA-P/PR	$V_{sa}$	lb (kN)	5,013 (22.3)	6,070 (27.0)	7,284 (32.4)	8,992 (40.0)	13,556 (60.3)	16,861 (75.0)	20,772 (92.4)
Steel strength in shear, seismic <sup>7, 8</sup> HDA-P/PR	$V_{sa,eq}$	lb (kN)	4,496 (20.0)	5,620 (25.0)	6,519 (29.0)	8,093 (36.0)	12,140 (54.0)	15,062 (67.0)	18,659 (83.0)
Axial stiffness in service load range in cracked / uncracked concrete	$\beta$	10 <sup>3</sup> lb/in	80 / 100						

<sup>1</sup>Actual  $h_{ef}$  for HDA-T is given by  $h_{ef,min} + (t - t_{fix})$  where  $t$  is given in Table 1 and  $t_{fix}$  is the thickness of the part(s) being fastened.

<sup>2</sup>See ACI 318-19 Section 17.5.3.

<sup>3</sup>The strength reduction factor applies when the load combinations from the IBC or ACI 318-19 are used and the requirements of ACI 318-19 Section 17.5.3 are met.

<sup>4</sup>See ACI 318-19 Section 17.6.2.2 and Section 4.1.3 of this report.

<sup>5</sup>See Section 4.1.3 of this report.

<sup>6</sup>See Section 4.1.4 of this report.

<sup>7</sup>For HDA-T/TR see Table 6.

<sup>8</sup>See Section 4.1.8 of this report.

<sup>9</sup>See Section 4.1.11 of this report.

<sup>10</sup>To calculate the basic concrete breakout strength in shear,  $V_b$ ,  $l_e$  equals  $h_{ef}$ . In no cases shall  $l_e$  exceed  $8d_a$ . See ACI 318-19 Section 17.7.2.2.1.

TABLE 6—DESIGN INFORMATION – STEEL STRENGTH IN SHEAR, HDA-T/TR

Anchor Designation		Thickness of fastened part(s), $t_{fix}$		Steel Strength in Shear Static, $V_{sa}$	Steel Strength in Shear, Seismic <sup>1</sup> , $V_{sa,eq}$
		(mm)	(in.)	(lb)	(lb)
Carbon Steel Anchors	HDA-T M10x100	$15 \leq t_{fix} \leq 20$	$5/8 \leq t_{fix} \leq 13/16$	13,940	12,590
	HDA-T M12x125	$15 \leq t_{fix} \leq 20$	$5/8 \leq t_{fix} \leq 13/16$	16,635	15,060
		$20 \leq t_{fix} \leq 50$	$13/16 \leq t_{fix} \leq 2$	18,660	16,635
	HDA-T M16x190	$20 \leq t_{fix} \leq 25$	$13/16 \leq t_{fix} \leq 1$	30,575	27,425
		$25 \leq t_{fix} \leq 30$	$1 \leq t_{fix} \leq 1-3/16$	34,620	31,250
		$30 \leq t_{fix} \leq 35$	$1-3/16 \leq t_{fix} \leq 1-3/8$	38,220	34,395
		$35 \leq t_{fix} \leq 60$	$1-3/8 \leq t_{fix} \leq 2-3/8$	41,365	37,095
	HDA-T M20x250	$25 \leq t_{fix} \leq 40$	$1 \leq t_{fix} \leq 1-9/16$	45,185	40,690
		$40 \leq t_{fix} \leq 55$	$1-9/16 \leq t_{fix} \leq 2-1/8$	50,805	45,635
		$55 \leq t_{fix} \leq 100$	$2-1/8 \leq t_{fix} \leq 4$	54,630	49,235
Stainless Steel Anchors	HDA-TR M10x100	$15 \leq t_{fix} \leq 20$	$5/8 \leq t_{fix} \leq 13/16$	15,510	13,940
	HDA-TR M12x125	$15 \leq t_{fix} \leq 20$	$5/8 \leq t_{fix} \leq 13/16$	20,235	17,985
		$20 \leq t_{fix} \leq 50$	$13/16 \leq t_{fix} \leq 2$	22,255	20,010
	HDA-TR M16x190	$20 \leq t_{fix} \leq 25$	$13/16 \leq t_{fix} \leq 1$	35,745	32,150
		$25 \leq t_{fix} \leq 30$	$1 \leq t_{fix} \leq 1-3/16$	37,770	33,945
		$30 \leq t_{fix} \leq 35$	$1-3/16 \leq t_{fix} \leq 1-3/8$	39,565	35,520
		$35 \leq t_{fix} \leq 60$	$1-3/8 \leq t_{fix} \leq 2-3/8$	40,915	36,870

For in-lb units: 1mm = 0.03937 inches, 1 Nm = 0.7376 ft\*lb

<sup>1</sup>See Section 4.1.8 of this report.

TABLE 7— APPLICABLE SECTIONS OF THE IBC CODE UNDER EACH EDITION OF THE IBC AND IRC

IBC			
2024 IBC	2021 IBC	2018 IBC	2015 IBC
Section 1605.1		Section 1605.2 or 1605.3	
	Section 1705		
	Section 1705.1.1		
	Table 1705.3		
	Section 1706		
	Section 1707		
	Section 1901.3		
	Section 1903		
	Section 1905		
Section 1905.7	Section 1905.1.8		
IRC			
2024 IRC	2021 IRC	2018 IRC	2015 IRC
Section R301.1.3			

**TABLE 8— APPLICABLE SECTIONS OF ACI 318 UNDER EACH EDITION OF THE IBC**

2024 IBC	2021 IBC	2018 IBC	2015 IBC
<b>ACI 318-19</b>		<b>ACI 318-14</b>	
5.3			5.3
Chapter 17			Chapter 17
17.3.1			17.2.7
17.5.1.2			17.3.1
17.5.3			17.3.3
17.6			17.4
17.6.1.2			17.4.1.2
17.6.2			17.4.2
17.6.2.2			17.4.2.2
17.6.2.5			17.4.2.6
17.6.2.6			17.4.2.7
17.7			17.5
17.7.1.2			17.5.1.2
Eq. 17.7.1.2(b)			Eq. 17.5.1.2b
17.7.2			17.5.2
17.7.2.2.1			17.5.2.2
17.7.3			17.5.3
17.8			17.6
17.9.2			17.7.1 and 17.7.3
17.9.4			17.7.5
17.9.5			17.7.6
17.10			17.2.3

**DIVISION: 03 00 00—CONCRETE**

Section: 03 16 00—Concrete Anchors

**DIVISION: 05 00 00—METALS**

Section: 05 05 19—Post-Installed Concrete Anchors

**REPORT HOLDER:**

HILTI, INC.

**EVALUATION SUBJECT:****HILTI HDA CARBON STEEL AND STAINLESS STEEL UNDERCUT ANCHORS FOR CRACKED AND UNCRACKED CONCRETE****1.0 REPORT PURPOSE AND SCOPE****Purpose:**

The purpose of this evaluation report supplement is to indicate that the Hilti HDA carbon steel and stainless steel undercut anchors for cracked and uncracked concrete, described in ICC-ES evaluation report [ESR-1546](#), have also been evaluated for compliance with the codes noted below as adopted by the Los Angeles Department of Building and Safety (LADBS).

**Applicable code editions:**

- 2023 *City of Los Angeles Building Code* ([LABC](#))
- 2023 *City of Los Angeles Residential Code* ([LARC](#))

**2.0 CONCLUSIONS**

The Hilti HDA carbon steel and stainless steel undercut anchors for cracked and uncracked concrete, described in Sections 2.0 through 7.0 of the evaluation report [ESR-1546](#), comply with LABC Chapter 19, and the LARC, and are subject to the conditions of use described in this supplement.

**3.0 CONDITIONS OF USE**

The Hilti HDA carbon steel and stainless steel undercut anchors for cracked and uncracked concrete described in this evaluation report supplement must comply with all of the following conditions:

- All applicable sections in the evaluation report [ESR-1546](#).
- The design, installation, conditions of use and labeling of the anchors are in accordance with the 2021 *International Building Code*® (IBC) provisions noted in the evaluation report [ESR-1546](#).
- The design, installation and inspection are in accordance with additional requirements of LABC Chapters 16 and 17, and the City of Los Angeles Information Bulletin P/BC 2020-092, as applicable.
- Under the LARC, an engineered design in accordance with LARC Section R301.1.3 must be submitted.
- The allowable and strength design values listed in the evaluation report and tables are for the connection of the anchors to the concrete. The connection between the anchors and the connected members shall be checked for capacity (which may govern).
- For the design of wall anchorage assemblies to flexible diaphragms, the anchor shall be designed per the requirements of City of Los Angeles Information Bulletin P/BC 2023-071.

This supplement expires concurrently with the evaluation report, reissued March 2026 and revised April 2026.

**DIVISION: 03 00 00—CONCRETE**  
**Section: 03 16 00—Concrete Anchors**

**DIVISION: 05 00 00—METALS**  
**Section: 05 05 19—Post-Installed Concrete Anchors**

**REPORT HOLDER:**

HILTI, INC.

**EVALUATION SUBJECT:**

**HILTI HDA CARBON STEEL AND STAINLESS STEEL UNDERCUT ANCHORS FOR CRACKED AND UNCRACKED CONCRETE**

**1.0 REPORT PURPOSE AND SCOPE**

**Purpose:**

The purpose of this evaluation report supplement is to indicate that the Hilti HDA Carbon Steel and Stainless Steel Undercut Anchors in cracked and uncracked concrete, described in ICC-ES evaluation report [ESR-1546](#), have also been evaluated for compliance with the codes noted below.

**Applicable code editions:**

- 2023 Florida Building Code—Building
- 2023 Florida Building Code—Residential

**2.0 CONCLUSIONS**

The Hilti HDA Carbon Steel and Stainless Steel Undercut Anchors in cracked and uncracked concrete, described in Sections 2.0 through 7.0 of ICC-ES evaluation report [ESR-1546](#), comply with the *Florida Building Code—Building* and the *Florida Building Code—Residential*, provided the design requirements are determined in accordance with the *Florida Building Code—Building* or the *Florida Building Code—Residential*, as applicable. The installation requirements noted in ICC-ES evaluation report [ESR-1546](#) for the 2021 *International Building Code*® meet the requirements of the *Florida Building Code—Building* or the *Florida Building Code—Residential*, as applicable.

Use of the Hilti HDA Carbon Steel and Stainless Steel Undercut Anchors in cracked and uncracked concrete have also been found to be in compliance with the High-Velocity Hurricane Zone provisions of the *Florida Building Code—Building* and the *Florida Building Code—Residential*, with the following condition:

- a) For anchorage of wood members, the connection subject to uplift must be designed for no less than 700 pounds (3114 N).

For products falling under Florida Rule 61G20-3, verification that the report holder's quality-assurance program is audited by a quality-assurance entity approved by the Florida Building Commission for the type of inspections being conducted is the responsibility of an approved validation entity (or the code official, when the report holder does not possess an approval by the Commission).

This supplement expires concurrently with the evaluation report, reissued March 2026 and revised April 2026.