

ICC-ES Evaluation Report

ESR-4143

Reissued January 2025

Revised April 2025

Subject to renewal January 2026

This report also contains:

- [City of LA Supplement](#)

- [FL Supplement w/ HVHZ](#)

ICC-ES Evaluation Reports are not to be construed as representing aesthetics or any other attributes not specifically addressed, nor are they to be construed as an endorsement of the subject of the report or a recommendation for its use. There is no warranty by ICC Evaluation Service, LLC, express or implied, as to any finding or other matter in this report, or as to any product covered by the report.

Copyright © 2025 ICC Evaluation Service, LLC. All rights reserved.

<p>DIVISION: 04 00 00— MASONRY</p> <p>Section: 04 05 19.16— Masonry Anchors</p>	<p>REPORT HOLDER: HILTI, INC.</p>	<p>EVALUATION SUBJECT: HILTI HIT-HY 270 ADHESIVE ANCHOR SYSTEM IN CRACKED AND UNCRACKED GROUTED AND UNGROUTED CONCRETE MASONRY UNIT WALLS AND CLAY BRICK MASONRY WALLS</p>	
---	---	--	---

1.0 EVALUATION SCOPE

Compliance with the following codes:

- 2024, 2021, 2018 and 2015 [International Building Code® \(IBC\)](#)
- 2024, 2021, 2018 and 2015 [International Residential Code® \(IRC\)](#)

Main references of this report are for the 2024 IBC and IRC. See [Table 16](#) and [Table 17](#) for applicable sections of the code for previous IBC and IRC editions.

Property evaluated:

- Structural

2.0 USES

The Hilti HIT-HY 270 Adhesive Anchor System is used as anchorage in cracked and uncracked concrete masonry unit (CMU) or clay brick masonry walls to anchor building components to grouted and ungrouted lightweight, medium-weight, or normal-weight concrete masonry wall construction or clay brick masonry wall construction. The adhesive anchors are designed to resist static, wind, and earthquake (Seismic Design Categories A through F) tension and shear loads.

The adhesive anchors are an alternative to cast-in-place anchors described in Section 9.1.6 of TMS 402 as referenced in Section 2108.1 of the IBC. The anchors are permitted to be used where an engineered design is submitted in accordance with Section R301.1.3 of the IRC.

3.0 DESCRIPTION

3.1 General:

The Hilti HIT-HY 270 Adhesive Anchor System is comprised of the following components:

- Hilti HIT-HY 270 adhesive
- All-threaded steel rods, steel reinforcing bars, or Hilti HIS-(R)N steel internally threaded inserts (grout-filled concrete masonry)
- All-threaded steel rods, bolts, cap screws, studs, Hilti HIT-IC internally threaded inserts, and Hilti HIT-SC plastic-mesh screen tubes (hollow concrete masonry and clay brick masonry)

- Adhesive mixing and dispensing equipment
- Equipment for hole cleaning and adhesive injection

The manufacturer's printed installation instructions (MPII) are included with each adhesive unit package as shown in [Figure 9](#) of this report.

3.2 Materials:

3.2.1 Hilti HIT-HY 270 Adhesive: The Hilti HIT-HY 270 is an injectable hybrid adhesive mortar consisting of urethane methacrylate resin, hardener, cement and water. The resin and cement are separated from the hardener and water by means of a dual-cylinder foil pack attached to a manifold. An injection nozzle with an internal mixing element is attached to the manifold, and the adhesive components are dispensed through the injection nozzle to ensure their proper mixing. The injection nozzle may be replaced to permit interruptions in the use of the cartridges. Available cartridge sizes include total mixed volumes of 11.1 ounces (330 mL) and 16.9 ounces (500 mL).

The adhesive expiration date is printed on the manifold of each foil pack (month/year). The shelf life, as indicated by the expiration date, is for an unopened foil pack stored in a cool, dry, dark environment and in accordance with [Figure 9](#).

3.2.2 Hole Cleaning Equipment:

3.2.2.1 Standard Equipment: Standard hole cleaning equipment, comprised of steel wire brushes and air nozzles is described in [Figure 9](#) of this report.

3.2.2.2 Hilti Safe-Set™ System: When the Hilti TE-CD or TE-YD hollow carbide drill with a carbide drilling head conforming to ANSI B212.15 is used in conjunction with a Hilti vacuum with a minimum value for the maximum volumetric flow rate of 129 CFM (61 ℓ /s), the Hilti TE-CD or TE-YD drill bit will remove drilling dust, automatically cleaning the hole.

3.2.3 Dispensers: Hilti HIT-HY 270 must be dispensed with manual or electric dispensers provided by Hilti.

3.2.4 Anchor Elements:

3.2.4.1 Threaded Steel Rods (For Use in Fully Grouted Concrete Masonry and with Plastic Mesh Screen Tubes in UngROUTED Concrete Masonry and Clay Brick Masonry): Threaded rods, having diameters described in [Table 2](#) of this report, must be clean, continuously threaded rods (all-thread). Carbon steel threaded rods must be in accordance with ASTM A36, ASTM A307, ASTM A193 Grade B7, ISO 898 Class 5.8. Stainless steel threaded rods must conform to ASTM F593 (AISI 304 or 316), Condition CW. Threaded steel rods must be straight and free of indentations or other defects along their lengths. The ends may be stamped with identifying marks and the embedded end may be blunt cut or cut on the bias (chisel point).

3.2.4.2 Steel Reinforcing Bars (For Use in Fully Grouted Concrete Masonry): Steel reinforcing bars are deformed reinforcing bars (rebar) having diameters described in [Table 3](#) of this report, and must comply with ASTM A615, Grade 60. The embedded portions of reinforcing bars must be straight, and free of mill scale, rust, mud, oil, and other coatings that impair the bond with the adhesive.

3.2.4.3 HIT-SC Screen Tubes: The Hilti HIT-SC plastic-mesh screen tubes are used in ungrouted concrete masonry and clay brick masonry as described in Sections 4.3, 4.4 and 4.5 of this report. The screens consist of a removable cap, a collar, and a plastic mesh tube.

3.2.4.4 HIT-IC Inserts (For Use With Plastic Mesh Screens in UngROUTED Concrete Masonry and Clay Brick Masonry): Hilti HIT-IC are steel internally threaded inserts conforming to DIN 10277-3 and are available in $5/16$ -, $3/8$ -, and $1/2$ -inch (7.9, 9.5, and 12.7 mm) internal thread diameters as described in [Table 4B](#). Common threaded rods as per Section 3.2.3.1, or bolts, cap screws, and studs conforming to SAE J429 Grade 5, ASTM A325, and ASTM A490, can be used with internally threaded inserts.

3.2.4.5 HIS-N and HIS-RN Inserts (For Use in Fully Grouted Concrete Masonry): Hilti HIS-N and HIS-RN steel inserts have a profile on the external surface and are internally threaded. Inserts are available in $3/8$ - and $1/2$ -inch (9.5 and 12.7 mm) internal thread diameters as described in [Table 4A](#). HIS-N inserts are produced from carbon steel and furnished either with a 0.005-millimeter-thick (5 mm) zinc electroplated coating complying with ASTM B633 SC 1 or a hot-dipped galvanized coating complying with ASTM A153, Class C or D. The stainless steel HIS-RN inserts conform to DIN 10088-3. Common threaded rods as per Section 3.2.3.1, or bolts, cap screws, and studs conforming to SAE J429 Grade 5, ASTM A325, ASTM A490, ASTM A193 Grade B8M (for use with HIS-RN), and ASTM A193 Grade B8T (for use with HIS-RN) can be used with internally threaded inserts. Bolt grade and material type (carbon, stainless) must be matched to the insert.

3.3 Grout-filled Concrete Masonry: Grouted concrete masonry must comply with Chapter 21 of the IBC. The compressive strength of masonry, f_m , at 28 days must be a minimum of 1,500 psi (10.3 MPa). Fully grouted masonry must be constructed from the following materials:

3.3.1 Concrete Masonry Units (CMUs): Grouted concrete walls must be constructed from minimum lightweight, medium-weight or normal-weight closed-end or open-end, concrete masonry units (CMUs) conforming to ASTM C90. The minimum allowable nominal size of the CMU is 8 inches (203 mm) wide by 8 inches (203 mm) high by 16 inches (406 mm) long.

3.3.2 Grout: Grout must comply with IBC Section 2103.3 or IRC Section R606.2.1218 IRC. Alternatively, the grout must have a minimum compressive strength, when tested in accordance with ASTM C1019, equal to its specified strength, but not less than 2,000 psi (13.8 MPa).

3.3.3 Mortar: Mortar must be Type N (minimum) in accordance with IBC Section 2103.2.1 or IRC Section R606.2.8.

3.4 Hollow (UngROUTED) Concrete Masonry: Hollow concrete masonry must comply with Chapter 21 of the IBC. The compressive strength of masonry, f_m , at 28 days must be a minimum of 1,500 psi (10.3 MPa). Hollow concrete masonry must be constructed from the following materials:

3.4.1 Concrete Masonry Units (CMUs): UngROUTED concrete walls must be constructed from minimum lightweight, medium-weight or normal-weight closed-end or open-end, concrete masonry units (CMUs) conforming to ASTM C90. The minimum allowable nominal size of the CMU is 8 inches (203 mm) wide by 8 inches (203 mm) high by 16 inches (406 mm) long.

3.4.2 Mortar: Mortar must be Type N (minimum) in accordance with IBC Section 2103.2.1 or IRC Section R606.2.8.

3.5 Clay Brick Masonry: Clay brick masonry must comply with Chapter 21 of the IBC. The compressive strength of masonry, f_m , at 28 days must be a minimum of 3,000 psi (20.7 MPa). Clay brick masonry walls must be a minimum of one wythe in thickness and constructed from the following materials:

3.5.1 Brick Masonry Units: Clay brick masonry must be constructed using hollow clay bricks conforming to ASTM C216 or ASTM C652, Grade SW. The minimum nominal size of the brick masonry units must be 3 ⁵/₈ inches (92 mm) wide by 2 ¹/₄ inches (57 mm) high by 7 ⁵/₈ inches (194 mm) long.

3.5.2 Mortar: Mortar must be Type N (minimum) in accordance with IBC Section 2103.2.1, or IRC Section R606.2.8.

4.0 DESIGN AND INSTALLATION

4.1 Strength Design in Fully Grouted Concrete Masonry Unit Construction:

4.1.1 General: Sections 4.1 and 4.2 provide strength design requirements for anchors used in fully grouted concrete masonry unit construction, where anchors are used to transmit structural loads by means of tension, shear or a combination of tension and shear.

Strength design of adhesive anchors in fully grouted concrete masonry unit construction shall be conducted in accordance with the provisions for the design of adhesive anchors in concrete in *ACI 318-19 Chapter 17*, and TMS 402-22 as modified by the sections that follow. Design in accordance with this report cannot be conducted without reference to *ACI 318 -19* with the deletions and modifications summarized in [Table 1A](#) and TMS 402-22 Eq. 9-5.

This report references sections, tables, and figures in both this report and ACI 318, with the following method used to distinguish between the two document references:

- References to sections, tables, and figures originating from ACI 318 are *italicized*. For example, Section 2.2 in ACI 318-19, will be displayed as *ACI 318-19 Section 2.2*.
- References to sections, tables, and figures originating from this report do not have any special font treatment, for example Section 4.2.1.

Where language from ACI 318 is directly referenced, the following modifications generally apply:

- The term “masonry” shall be substituted for the term “concrete” wherever it occurs.
- The modification factor to reflect the reduced mechanical properties for mixtures with lightweight aggregate and lightweight units, λ_a , shall be taken as 1.0.

The following terms shall be replaced wherever they occur:

ACI 318 (-19 or -14) term	Replacement term
f'_c	f'_m
N_{cb}, N_{cbg}	N_{mb}, N_{mbg}
N_a, N_{ag}	N_{ma}, N_{mag}
V_{cb}, V_{cbg}	V_{mb}, V_{mbg}
V_{cp}, V_{cpg}	V_{mp}, V_{mpg}

4.1.2 Restrictions for anchor placement are noted in [Table 5](#) and shown in [Figure 1](#). For CMU construction with closed end blocks and hollow head joints, in addition to the ends and edges of walls, the nearest head joint on a horizontal projection from the anchor shall be treated as an edge for design purposes. The minimum distance from the nearest adjacent head joint shall be 2 inches (50.8 mm) as measured from the centerline of the head joint in CMU construction with hollow head joints. For anchor groups installed in CMU construction with solid head joints, the nearest head joint outside of the group on a horizontal projection to the group shall be treated as an edge. If open-ended units are employed, only the ends and edges of walls shall be considered for edge distance determination. For horizontal ledgers in fully-grouted CMU walls with hollow head joint applications, see Section 4.2.20.

4.2 ACI Modifications Required for Design: [Table 1A](#) provides a summary of all applicable *ACI 318-19* and *ACI 318-14* sections for the design of adhesive anchors in fully grouted masonry. Where applicable, modifying sections contained within this report are also provided.

4.2.1 *ACI 318-19 Section 17.1.1, 17.1.6 & 17.2.2* apply with the general changes prescribed in Section 4.1.1.

4.2.2 In lieu of *ACI 318-19 Section 17.1.2*: Design provisions are included for adhesive anchors that meet the assessment criteria of ICC-ES AC58.

4.2.3 *ACI 318-19 Section 17.1.4, 17.2.1, 17.4.1 & 17.5.1.3.1* apply with the general changes prescribed in Section 4.1.1.

4.2.4 In lieu of *ACI 318-19 Section 17.10*: The design of anchors in structures assigned to Seismic Design Category (SDC) C, D, E, or F shall satisfy the requirements of this section.

4.2.4.1 The design of anchors in the plastic hinge zones of masonry structures under earthquake forces is beyond the scope of these acceptance criteria.

4.2.4.2 The anchor or group of anchors shall be designed for the maximum tension and shear obtained from the design load combinations that include E , with E_h increased by Ω_o . The anchor design tensile strength shall satisfy the tensile strength requirements of Section 4.2.4.3.

4.2.4.3 The anchor design tensile force for resisting earthquake forces shall be determined from consideration of (a) through (c) for the failure modes given in [Table 1B](#) assuming the masonry is cracked unless it can be demonstrated that the masonry remains uncracked.

(a) ϕN_{sa} for a single anchor, or for the most highly stressed individual anchor in a group of anchors.

(b) $0.75 \phi N_{mb}$ or $0.75 \phi N_{mbg}$.

(c) $0.75 \phi N_{ma}$ or $0.75 \phi N_{mag}$.

(d) where ϕ is in accordance with Section 4.2.9

4.2.5 In lieu of *ACI 318-19 Section 17.5.1.3 & 17.5.2.2.1*: For anchors designed for sustained tension loading, *ACI 318-19 Section 17.5.2.2* shall be satisfied. For groups of anchors, *ACI 318-19 Eq. 17.5.2.2* shall be satisfied for the anchor that resists the highest sustained tension load. Inspection requirements for horizontal anchors designed for sustained tension loading shall be in accordance with *ACI 318-19 Section 26.13.3.2(e)*. Installers of such anchors shall be qualified for the installation of the anchor type used.

4.2.6 In lieu of *ACI 318-19 Section 17.5.2*: The design of anchors shall be in accordance with [Table 1B](#). In addition, the design of anchors shall satisfy Section 4.2.4 for earthquake loading and *ACI 318-19 Section 17.5.2.2* for anchors designed for sustained tensile loading.

4.2.7 *ACI 318-19 Section 17.5.2.2-17.5.2.3* applies with the general changes prescribed in Section 4.1.1.

4.2.8 *ACI 318-19 Section 17.5.1.2* applies with the general changes prescribed in Section 4.1.1.

4.2.9 In lieu of *ACI 318-19 Section 17.5.3*: Strength reduction factor ϕ for anchors in masonry shall be as follows when the LRFD load combinations of ASCE 7 are used:

- a. For steel capacity of ductile steel elements as defined in *ACI 318-19 Section 2.3*, ϕ shall be taken as 0.75 in tension and 0.65 in shear. Where the ductility requirements of ACI 318 are not met, ϕ shall be taken as 0.65 in tension and 0.60 in shear.
- b. For shear crushing capacity, ϕ shall be taken as 0.50.
- c. For cases where the nominal strength of anchors in masonry is controlled by masonry breakout in tension, ϕ shall be taken as 0.65.
- d. For cases where the nominal strength of anchors in masonry is controlled by masonry failure modes in shear, ϕ shall be taken as 0.70.
- e. For cases where the nominal strength of anchors in masonry is controlled by bond failure or pullout failure, ϕ shall be taken as 0.65 for anchors qualifying for Category 1 and 0.55 for anchors qualifying for Category 2.

4.2.10 *ACI 318-19 Section 17.6.1* applies with the general changes prescribed in Section 4.1.1.

4.2.11 In lieu of *ACI 318-19 Section 17.6.2.1*: The nominal breakout strength in tension, N_{mb} of a single anchor or N_{mbg} of a group of anchors, shall not exceed:

- a. For a single anchor:

$$N_{mb} = \frac{A_{Nm}}{A_{Nm0}} \psi_{ed,N,m} \cdot \psi_{c,N,m} \cdot N_{b,m} \quad (17.6.2.1a)$$

- b. For a group of anchors:

$$N_{mbg} = \frac{A_{Nm}}{A_{Nm0}} \psi_{ec,N,m} \cdot \psi_{ed,N,m} \cdot \psi_{c,N,m} \cdot N_{b,m} \quad (17.6.2.1b)$$

Factors $\psi_{ec,N,m}, \psi_{ed,N,m}, \psi_{c,N,m}$ are defined in *ACI 318-19 Section 17.6.2.3-17.6.2.5*. A_{Nm} is the projected masonry failure area of a single anchor or group of anchors that shall be approximated as the base of the rectilinear geometrical figure that results from projecting the failure surface outward $1.5h_{ef}$ from the centerlines of the anchor, or, in the case of a group of anchors, from a line through a row of adjacent anchors. A_{Nm} shall not exceed $n \cdot A_{Nm0}$, where n is the number of anchors in the group that resist tension. A_{Nm0} is the projected masonry failure area of a single anchor with an edge distance equal to or greater than $1.5h_{ef}$.

$$A_{Nm0} = 9h_{ef}^2 \quad (17.6.2.1.4)$$

4.2.12 In lieu of *ACI 318 Section 17.6.2.2*: The basic masonry breakout strength of a single anchor in tension in cracked masonry, $N_{b,m}$, shall not exceed:

$$N_{b,m} = k_m \sqrt{f'_m} h_{ef}^{1.5} \quad (17.6.2.2.1)$$

where

$$\begin{aligned} k_m &= \text{effectiveness factor for breakout strength in masonry} \\ &= \alpha_{masonry} \cdot k_c \\ k_c &= \text{effectiveness factor for breakout strength in concrete} \\ &= 17; \text{ and} \end{aligned}$$

$\alpha_{masonry}$ = reduction factor for the inhomogeneity of masonry materials in breakout and bond strength determination.

$$= 0.7$$

4.2.13 *ACI 318-19 Section 17.6.2.1.2 & 17.6.2.3-17.6.2.4* apply with the general changes prescribed in Section 4.1.1.

4.2.14 In lieu of *ACI 318-19 Section 17.6.2.5*: The basic masonry breakout strength of a single anchor in tension, $N_{b,m}$, must be calculated using the values of $k_{m,cr}$ and $k_{m,uncr}$ as described in [Table 6](#). Where analysis indicates no cracking is anticipated, $N_{b,m}$ must be calculated using $k_{m,uncr}$ and $\Psi_{c,N,m} = 1.0$.

4.2.15 *ACI 318-19 Section 17.6.2.6* need not be considered since the modification factor for post installed anchors, $\psi_{cp,N}$ is not included in Eq. 17.6.2.1a & b.

4.2.16 In lieu of *ACI 318-19 Section 17.6.5.1*: The nominal bond strength in tension, N_{ma} , of a single anchor or N_{mag} of a group of anchors, shall not exceed:

- 4.2.16.1** For a single anchor:

$$N_{ma} = \frac{A_{Na}}{A_{Na0}} \psi_{ed,Na} \cdot N_{ba,m} \quad (17.6.5.1a)$$

4.2.16.2 For a group of anchors:

$$N_{mag} = \frac{A_{Na}}{A_{Na0}} \psi_{ec,Na} \cdot \psi_{ed,Na} \cdot N_{ba,m} \quad (17.6.5.1b)$$

Factors $\psi_{ec,Na}$ and $\psi_{ed,Na}$ are defined in *ACI 318-19 Sections 17.6.5.3-17.6.5.4*. A_{Na} is the projected influence area of a single anchor or group of anchors that shall be approximated as a rectilinear area that projects outward a distance c_{Na} from the centerlines of the anchor, or in the case of a group of anchors, from a line through a row of adjacent anchors. A_{Na} shall not exceed nA_{Na0} , where n is the number of anchors in the group that resist tension. A_{Nmo} is the projected masonry failure area of a single anchor with an edge distance equal to or greater than c_{Na} .

$$A_{Na0} = (2c_{Na})^2 \quad (17.6.5.1.2a)$$

where

$$c_{Na} = 10d_a \sqrt{\frac{\tau_{uncr}}{1100}} \quad (17.6.5.1.2b)$$

and constant 1100 carries the unit of lb./in.²

4.2.17 *In lieu of ACI 318-19 Section 17.6.5.2:* The basic bond strength of a single adhesive anchor in cracked masonry, $N_{ba,m}$, shall not exceed:

$$N_{ba,m} = \tau_{cr,m} \cdot \pi \cdot d_a \cdot h_{ef} \quad (17.6.5.2.1)$$

The characteristic bond stresses $\tau_{cr,m}$ shall be taken from [Table 7](#), [8](#), or [9](#). For adhesive anchors located in a region of a masonry member where analysis indicates no cracking at service load levels, $\tau_{uncr,m}$ shall be permitted to be used in place of $\tau_{cr,m}$ in *ACI 318-19 Eq. 17.6.5.2.1* and shall be taken as the value of $\tau_{k,uncr}$ as determined from [Table 7](#), [8](#), or [9](#).

4.2.18 The following apply with the general changes prescribed in Section 4.1.1:

1. *ACI 318-19 Section 17.6.5.3-17.6.5.4.*
2. *ACI 318-19 Section 17.7.1 excluding Sections 17.7.1.2a & 17.7.1.2c .*
3. *ACI 318-19 Sections 17.7.2.1-17.7.2.2.1 .*
4. *ACI 318-19 Section 17.7.2.1.2 & 17.7.2.3-17.7.2.4.*
5. *ACI 318-19 Section 17.7.2.6.*
6. *ACI 318-19 Section 17.7.3.*
7. *ACI 318-19 Section 17.2.5.*

4.2.19 *In lieu of ACI 318-19 Section 17.7.2.5 :* For anchors located in a region of masonry construction where cracking is anticipated, $\psi_{m,v}$ shall be taken as 1.0. for cases where analysis indicates no cracking at service levels, it shall be permitted to take $\psi_{m,v}$ as 1.4.

[In addition to the ACI 318 provisions] Masonry crushing strength for anchors in shear shall be calculated in accordance with TMS 402-22 Eq. 9-5 —The nominal strength of an anchor in shear as governed by masonry crushing, V_{mc} , shall be calculated using Eq. (3-1).

$$V_{mc} = 1750 \sqrt{f'_m A_{se,v}} \quad (3-1)$$

4.2.20 Determination of shear capacity for anchors in horizontal ledgers in fully-grouted CMU walls with hollow head joint applications with an assumed masonry unit length of 16 inches, standard:

Where six or more anchors are placed at uniform horizontal spacing in continuous wood or steel ledgers connecting floor and roof diaphragms to fully grouted CMU walls constructed with hollow head joints (using closed-end block), the horizontal and vertical shear capacity of the anchors may be permitted to be calculated in accordance with Eq. (3-1.1) and Eq. (3-1.2), respectively, in lieu of Section 3.3.1.2.

$$V_{mb,horiz} = 0.75 \cdot V_{gov,horiz} \cdot \frac{12}{S_{horiz}} \quad (3-1.1)$$

$$V_{mb,vert} = 0.75 \cdot V_{gov,vert} \cdot \frac{12}{S_{horiz}} \quad (3-1.2)$$

where:

S_{horiz} = horizontal anchor spacing in the ledger, (in). For anchor spacings that are multiples of 8 inches, locate the first anchor in the ledger at least 2 inches from the head joint and the center of the block. For other anchor spacings, minimum edge distance as specified in the evaluation report shall apply.

$V_{gov,horiz} = \min(V_{sa}, V_{mb,4}, V_{mc}, V_{mp,4}), (\text{lb}).$

$V_{gov,vert} = \min(V_{sa}, 2 \cdot V_{mb,4}, V_{mc}, V_{mp,4}), (\text{lb}).$

V_{sa} = shear capacity for a single anchor calculated in accordance with *ACI 318-19 Section 17.7.1.2*, (lb).

$V_{mb,4}$ = breakout capacity for a single anchor with edge distance of 4 inches, (lb).

V_{mc} = crushing capacity for a single anchor calculated in accordance with Eq. (3-1), (lb).

$V_{mp,4}$ = pryout capacity for a single anchor with edge distance of 4 inches, (lb).

Where anchors are spaced at 8" on center or another multiple of 8" on center, multiply the calculated $V_{mb,horiz}$ and $V_{mb,vert}$ by $\frac{4}{3}$.

4.2.21 In lieu of *ACI 318-19 Section 26.7.1(i)*: The construction documents shall specify all parameters associated with the characteristic bond stress used for design in accordance with Section 4.2.16 and Section 4.2.17, including minimum age of masonry; masonry temperature range; moisture condition of masonry at time of installation; type of lightweight masonry, if applicable; and requirements for hole drilling and preparation.

4.2.22 *ACI 318-19 Section 26.7.2(e)* applies with the general changes prescribed in Section 4.1.1.

4.2.23 Interaction shall be calculated in compliance with *ACI 318-19 17.8* as follows:

For shear loads $V \leq 0.2V_{allowable,ASD}$, the full allowable load in tension shall be permitted.

For tensile loads $T \leq 0.2T_{allowable,ASD}$, the full allowable load in shear shall be permitted.

For all other cases:

$$\frac{T}{T_{allowable}} + \frac{V}{V_{allowable}} \leq 1.2$$

4.2.24 Satisfying the parabolic equation complying with *ACI 318-19 Section R17.8* may be used in lieu of satisfying Section 4.2.23. The parabolic equation is given as:

$$\left(\frac{N_{ua}}{\phi N_n}\right)^{5/3} + \left(\frac{V_{ua}}{\phi V_n}\right)^{5/3} = 1$$

4.3 Strength Design in Hollow (Ungrouted) Concrete Masonry Unit Construction:

4.3.1 General: This section provides strength design requirements for anchors used in ungrouted concrete masonry unit construction, where anchors are used to transmit structural loads by means of tension, shear or a combination of tension and shear.

4.3.2 The use of a screen tube or similar device to prevent unrestricted flow of adhesive is required.

4.3.3 Anchors shall be designed for critical effects of factored loads as determined by elastic analysis. Plastic analysis shall not be permitted.

4.3.4 Group effects shall not be considered. Dimensional requirements specified in [Table 10](#) shall be observed for the design of individual anchors as follows:

4.3.4.1 The critical edge distance, c_{cr} , is the smallest edge distance to consider full capacity of an individual anchor and the minimum edge distance, c_{min} , shall be the smallest distance an anchor may be installed with a reduced capacity per the multiplier listed in [Table 10](#). For anchors installed with edge distances between c_{cr} and c_{min} , capacities shall be linearly interpolated. The minimum distance from hollow head joints shall be 2 inches (50.8 mm) as measured from the centerline of the head joint.

4.3.4.2 For anchor spacings less than the minimum spacing, s_{min} , the strength of the group shall equal the strength of a single anchor.

4.3.5 Anchors designed for sustained tensile loading shall be in accordance with Section 4.2.5.

4.3.6 Strength design checks shall be in accordance with [Table 1C](#). In addition, the design of anchors shall satisfy Section 4.2.5 for anchors designed for sustained tensile loading.

4.3.7 The strength reduction factors, ϕ , shall be in accordance with Section 4.2.9, as applicable.

4.3.8 The nominal steel strength of anchors in tension shall be calculated in accordance with Section 4.2.10.

4.3.9 The nominal pullout strength of anchors in tension, N_k , shall be taken from [Tables 11](#) and [12](#).

4.3.10 The nominal anchorage strength of anchors in shear, V_s , shall be taken from [Tables 11](#) and [12](#).

4.3.11 The nominal steel strength of an anchor in shear, V_{sa} , shall be calculated in accordance with Section 4.2.18 (2).

4.3.12 The nominal strength of an anchor in shear as governed by crushing, V_{mc} , shall be calculated in accordance with Section 4.2.19.

4.3.13 Anchors designed for combinations of tension and shear shall satisfy the provisions of Section 4.2.23.

4.3.14 The provisions of Sections 4.2.18.7, 4.2.21, and 4.2.22 shall apply.

4.4 Strength Design in Partially Grouted Concrete Masonry Unit Construction:

4.4.1 In all cases, the minimum distance from hollow head joints shall be 2 inches as measured from the centerline of the head joint.

4.4.2 For cases where the location of grouted cells is known, the following provisions shall apply:

4.4.2.1 Group effects shall not be considered between anchors in grouted masonry and anchors in ungrouted masonry.

4.4.2.2 Anchors located in grouted cells shall be designed in accordance with Sections 4.1 and 4.2, whereby the distance to the extent of the ungrouted cell shall be taken as a free edge.

4.4.2.3 Anchors in ungrouted cells shall be designed in accordance with Section 4.3, whereby the use of a screen tube or similar device to prevent unrestricted flow of adhesive is required.

4.4.3 For cases where the location of grouted cells is unknown, the design of anchors shall be in accordance with Section 4.3.

4.5 Strength Design in Clay Brick Masonry Construction

4.5.1 General: This section provides strength design requirements for anchors used in clay brick masonry construction, where anchors are used to transmit structural loads by means of tension, shear, or a combination of tension and shear.

4.5.2 The use of a screen tube or similar device to prevent unrestricted flow of adhesive is required.

4.5.3 Anchors shall be designed for critical effects of factored loads as determined by elastic analysis. Plastic analysis shall not be permitted.

4.5.4 Group effects shall not be considered. Dimensional requirements specified in [Table 13](#) shall be observed for the design of individual anchors.

4.5.4.1 The critical edge distance, c_{cr} , is the smallest edge distance to consider full capacity of an individual anchor and the minimum edge distance, c_{min} , shall be the smallest distance an anchor may be installed with a reduced capacity per the multiplier listed in [Table 13](#). For anchors installed with edge distances between c_{cr} and c_{min} , capacities shall be linearly interpolated.

4.5.4.2 For anchor spacings less than the minimum spacing, s_{min} , the strength of the group shall equal the strength of a single anchor.

4.5.5 Anchors designed for sustained tensile loading shall be in accordance with Section 4.2.5.

4.5.6 Strength design checks shall be in accordance with [Table 1D](#). In addition, the design of anchors shall satisfy Section 4.2.5 for anchors designed for sustained tensile loading.

4.5.7 The strength reduction factors, ϕ , shall be in accordance with Section 4.2.9.

4.5.8 The nominal steel strength of anchors in tension shall be calculated in accordance with Section 4.2.10.

4.5.9 The nominal pullout strength of anchors in tension, N_k , shall be taken from [Tables 14](#) and [15](#).

4.5.10 The nominal anchorage strength of anchors in shear, V_s , shall be taken from [Tables 14](#) and [15](#).

4.5.11 The nominal steel strength of an anchor in shear, V_{sa} , shall be calculated in accordance with Section 4.2.18(2).

4.5.12 The nominal strength of an anchor in shear as governed by crushing, V_{mc} , shall be calculated in accordance with Section 4.2.19.

4.5.13 Anchors designed for combinations of tension and shear shall satisfy the provisions of Section 4.2.23.

4.5.14 The provisions of Section 4.2.18(7), 4.2.21, and 4.2.22 shall apply.

4.6 Conversion of Strength Design to Allowable Stress Design:

For adhesive anchors designed using load combinations in accordance with IBC Section 1605.1 (Allowable Stress Design) allowable loads shall be established using the equations below:

$$T_{allowable,ASD} = \frac{\phi N_n}{\alpha} \quad (3-2)$$

and

$$V_{allowable,ASD} = \frac{\phi V_n}{\alpha} \quad (3-3)$$

where

$T_{allowable,ASD}$ = Allowable tensile load (lb. or kN);

$V_{allowable,ASD}$ = Allowable shear load (lb. or kN);

N_n = Lowest design strength of an anchor or anchor group in tension as determined in accordance with this report (lb. or kN);

V_n = Lowest design strength of an anchor or anchor group in shear as determined in accordance with this report (lb or kN);

α = Conversion factor calculated as a weighted average of the load factors for the controlling load combination. In addition, α shall include all applicable factors to account for non-ductile failure modes and required overstrength; and

ϕ = *relevant* strength reduction factor for load case and Anchor Category.

4.7 Installation: Installation parameters are illustrated in [Figures 2, 3, 4, 5, 6, 7, and 8](#) Installation of the Hilti HIT-HY 270 Adhesive Anchor System must conform to the manufacturer's printed installation instruction (MPII) included in each unit package as provided in [Figure 9](#) of this report. Anchor locations must comply with this report and the plans and specifications approved by the code official.

4.8 Special Inspection

At a minimum, periodic special inspection shall be provided for all anchors in accordance with the IBC and is also applicable for installations under the IRC. Continuous special inspection shall be provided for anchors installed in horizontally inclined orientations and designed to resist sustained tension loads. Installation in head joints shall only be permitted in fully grouted walls constructed with open-ended units, fully grouted bond beams or any other type of construction where the head joint void is filled.

The special inspector must be on the jobsite initially during anchor installation to verify anchor type, anchor dimensions, adhesive identification and expiration date, masonry type, masonry compressive strength, drill bit size and compliance with ANSI B212.15-1994, hole dimensions, hole cleaning procedures, installation outside of hollow head joints, anchor spacing, edge distances, masonry thickness, anchor embedment, tightening torque, base-material temperature, and adherence to the manufacturer's printed installation instructions (MPII).

The special inspector must verify the initial installations of each type and size of adhesive anchor by construction personnel on the site.

For periodic inspection, subsequent installations of the same anchor type and size by the same construction personnel are permitted to be performed in the absence of the special inspector. Any change in the anchor product being installed or the personnel performing the installation requires an initial inspection. For ongoing installations over an extended period, the special inspector must make regular inspections to confirm correct handling and installation of the product.

The special inspector must inspect and verify that anchor installation complies with this evaluation report and Hilti's published installation instructions.

5.0 CONDITIONS OF USE:

The Hilti HIT-HY 270 Adhesive Anchor System described in this report is a suitable alternative to what is specified in, those codes listed in Section 1.0 of this report, subject to the following conditions:

- 5.1 The Hilti HIT-HY 270 Adhesive Anchor System must be installed in accordance with the manufacturer's printed installation instructions (MPII) and this report. In case of conflict, this report governs.
- 5.2 Anchors have been evaluated for use in cracked and uncracked grouted and ungrouted concrete masonry unit (CMU) construction with a minimum compressive strength of 1,500 psi (10.3 MPa) at the time of anchor installation.
- 5.3 Anchors have been evaluated for use in cracked and uncracked clay brick masonry construction with a minimum compressive strength of 3,000 psi (20.7 MPa) at the time of anchor installation.
- 5.4 Anchor sizes, dimensions, and minimum embedment depths must be as set forth in this report.

- 5.5** Prior to installation, calculations and details demonstrating compliance with this report must be submitted to the code official for approval. The calculations must be prepared by a registered design professional when required by the statutes of the jurisdiction in which the project is to be constructed.
- 5.6** Anchors installed in the face or the top of fully grouted CMU masonry may be used to resist short-term loading due to wind or seismic forces in structures assigned to Seismic Design Categories A through F under the IBC.
- Anchors installed in ungrouted (hollow) CMU masonry and clay brick masonry may be used to resist short-term loading due to wind or seismic forces in structures assigned to Seismic Design Categories A and B only under the IBC.
- Loads applied to the anchors must be adjusted in accordance with Section 1605.1 of the 2024 IBC for strength design and in accordance with Section 1605.1 of the 2024 IBC for allowable stress design.
- 5.7** Strength design values shall be established in accordance with Sections 4.1, 4.2, 4.3, 4.4, and 4.5 of this report.
- 5.8** Allowable design values shall be established in accordance with Section 4.6 of this report.
- 5.9** Design of anchors in fully grouted CMU construction must avoid location of anchors in hollow head joints.
- 5.10** Since an ICC-ES acceptance criteria for evaluating data to determine the performance of adhesive anchors subjected to fatigue or shock loading is unavailable at this time, the use of these anchors under these conditions is beyond the scope of this report.
- 5.11** The Hilti HIT-HY 270 Adhesive Anchor System may be used to resist tension and shear forces in wall installations only if consideration is given to the effects of elevated temperature conditions on anchor performance.
- 5.12** Anchors are not permitted to support fire-resistive construction. Where not otherwise prohibited by the code, anchors are permitted for installation in fire-resistive construction provided that at least one of the following conditions is fulfilled:
- Anchors are used to resist wind or seismic forces only.
 - Anchors that support gravity load-bearing structural elements are within a fire-resistive envelope or a fire-resistive membrane, are protected by approved fire-resistive materials, or have been evaluated for resistance to fire exposure in accordance with recognized standards.
 - Anchors are used to support nonstructural elements.
- 5.13** The design of anchors must be in accordance with the provisions for cracked masonry where analysis indicates that cracking may occur ($f_t > f_r$) in the vicinity of the anchor due to service loads or deformations over the anchor service life.
- 5.14** Use of carbon steel anchors is limited to dry, interior locations.
- 5.15** Use of stainless steel anchors or hot dipped galvanized anchors with a zinc coating conforming to ASTM A153, Class C or D, is permitted for exterior exposure for damp environments.
- 5.16** The Hilti HIT-HY 270 Adhesive Anchor System may be installed in base materials having interior temperatures between 23°F (-5°C) and 104°F (40°C) at the time of installation. Installation of HIT-HY 270 adhesive in base materials having temperatures beyond this range is outside the scope of this report.
- 5.17** Anchors are not permitted for tightening torque installation until adhesive cure time indicated in the MPII is fully reached.
- 5.18** Steel anchoring materials in contact with preservative-treated wood or fire-retardant-treated wood must be stainless steel or hot-dipped galvanized in accordance with ASTM A153 Class C or D or ASTM B695 Class 55 minimum coating.
- 5.19** Special inspection, where required, must be provided in accordance with Section 4.8. Continuous special inspection must be provided for anchors designed to resist sustained tension loads.
- 5.20** The Hilti HIT-HY 270 Adhesive Anchor System must be installed in holes created using a carbide-tipped masonry drill bit manufactured within the range of the maximum and minimum dimensions of ANSI B212.15-1994 in accordance with the instructions provided in [Figures 2, 3, 4, 5, 6, 7, and 8](#) of this report.
- 5.21** Anchors are not permitted for overhead installations.
- 5.22** The Hilti HIT-HY 270 adhesive is manufactured by Hilti GmbH at their facilities in Kaufering, Germany, under a quality control program with inspections by ICC-ES.

- 5.23 The Hilti HIT-SC plastic screens are manufactured by Hilti Kunststofftechnik GmbH, Nersingen, Germany, with quality control inspections by ICC-ES.
- 5.24 The Hilti HIT-IC inserts are manufactured by Hilti (China) Ltd., Guangdong, China, with quality control inspections by ICC-ES.
- 5.25 The Hilti HIS-N and HIS-RN inserts are manufactured by Hilti (China) Ltd., Guangdong, China, with quality control inspections by ICC-ES.

6.0 EVIDENCE SUBMITTED

- 6.1 Data in accordance with [ICC-ES Acceptance Criteria for Adhesive Anchors in Cracked and Uncracked Masonry Elements AC58 \(24\) 2nd Edition](#), Published April 2025.
- 6.2 A quality-control manual.

7.0 IDENTIFICATION

- 7.1 The ICC-ES mark of conformity, electronic labeling, or the evaluation report number (ICC-ES ESR-4143) along with the name, registered trademark, or registered logo of the report holder must be included in the product label.
- 7.2 In addition, the Hilti HIT-HY 270 adhesive cartridges are identified by a label displaying the product name, name of the manufacturer (Hilti, Inc.), lot number, expiration date, description of the product, and evaluation report number (ICC-ES ESR-4143).
- 7.3 The Hilti HIT-SC plastic screens are identified by a packaging label displaying the product name, name of the manufacturer (Hilti Inc.), description of the product, and evaluation report number (ICC-ES ESR-4143).
- 7.4 The Hilti HIS-N and HIS-RN inserts are identified by a packaging label displaying the product name, name of the manufacturer (Hilti Inc.), description of the product, and evaluation report number (ICC-ES ESR-4143).
- 7.5 The Hilti HIT-IC inserts are identified by a packaging label displaying the product name, name of the manufacturer (Hilti Inc.), description of the product, and evaluation report number (ICC-ES ESR-4143).
- 7.6 Threaded rods, reinforcing bars, nuts, washers, bolts, cap screws, and studs are standard elements, and must conform to applicable national or international specifications and this report.
- 7.7 The report holder's contact information is the following:

HILTI, INC.
7250 DALLAS PARKWAY, SUITE 1000
PLANO, TEXAS 75024
(800) 879-8000
www.us.hilti.com

TABLE 1A — ACI 318-19, and -14 SECTIONS APPLICABLE OR MODIFIED BY THIS REPORT

ACI 318-19 Section	(ACI 318-14 Section)	Modified by this report Section:
2.2	(2.2)	Unchanged*
2.3	(2.3)	
17.1.1, 17.1.6 & 17.2.2	(17.1.1 – 17.1.2)	
17.1.2	(17.1.3)	Section 4.2.2
17.1.4, 17.2.1, 17.4.1, & 17.5.1.3.1	(17.1.4 – 17.2.2)	Unchanged*
17.10	(17.2.3)	Section 4.2.4
17.5.1.3 & 17.5.2.2	(17.2.5)	Section 4.2.5
17.5.2	(17.3.1.1)	Section 4.2.6
17.5.2.2 – 17.5.2.3	(17.3.1.2 – 17.3.1.3)	Unchanged*
17.5.1.2	(17.3.2 excluding 17.3.2.1)	
17.5.3	(17.3.3)	Section 4.2.9
17.6.1	(17.4.1)	Unchanged*
17.6.2.1	(17.4.2.1)	Section 4.2.11
17.6.2.2	(17.4.2.2)	Section 4.2.12
17.6.2.1.2 & 17.6.2.3 – 17.6.2.4	(17.4.2.3 – 17.4.2.5)	Unchanged*
17.6.2.5	(17.4.2.6)	Section 4.2.14
17.6.2.6	(17.4.2.7)	Section 4.2.15
17.5.2.1	(17.4.2.9)	Unchanged*
17.6.5.1	(17.4.5.1)	Section 4.2.16
17.6.5.2	(17.4.5.2)	Section 4.2.17
17.6.5.3 – 17.6.5.4	(17.4.5.3 – 17.4.5.4)	Unchanged*
17.7.1.1 – 17.7.2.2	(17.5.1.1 – 17.5.2.2)	
17.7.2.1.2 & 17.7.2.3 – 17.7.2.4	(17.5.2.4 – 17.5.2.6)	
17.7.2.6	(17.5.2.8)	
17.7.3	(17.5.3)	
17.8	(17.6)	
17.2.5	(17.8.1)	
17.7.2.5	(17.5.2.7)	
26.7.1(i)	(17.8.2.1)	
26.7.2(e)	(17.8.2.4)	
17.8	(17.6)	Unchanged*
R17.8	(R17.6)	
17.9.2 and 17.9.5	17.7.1, 17.7.3, and 17.7.6	
26.13.3.2(e)	(17.8.2.4)	

*Sections marked as unchanged adopt the general changes prescribed in Section 4.1.1.

TABLE 1B — REQUIRED STRENGTH OF ANCHORS IN FULLY GROUTED CMU

Failure mode	Single anchor	Anchor group ¹	
		Individual anchor in a group	Anchors as a group
Steel strength in tension	$\phi N_{sa} \geq N_{ua}$	$\phi N_{sa} \geq N_{ua,i}$	
Masonry breakout strength in tension	$\phi N_{mb} \geq N_{ua}$		$\phi N_{mbg} \geq N_{ua,g}$
Bond strength in tension	$\phi N_{ma} \geq N_{ua}$		$\phi N_{mag} \geq N_{ua,g}$
Steel strength in shear	$\phi V_{sa} \geq V_{ua}$	$\phi V_{sa} \geq V_{ua,i}$	
Masonry breakout strength in shear	$\phi V_{mb} \geq V_{ua}$		$\phi V_{mbg} \geq V_{ua,g}$
Masonry crushing strength in shear	$\phi V_{mc} \geq V_{ua}$	$\phi V_{mc} \geq V_{ua,i}$	
Masonry pryout strength in shear	$\phi V_{mp} \geq V_{ua}$		$\phi V_{mpg} \geq V_{ua,g}$

¹Required strengths for steel and crushing failure modes shall be calculated for the most highly stressed anchor in the group.

TABLE 1C — REQUIRED STRENGTH OF ANCHORS IN UNGROUTED CMU

Failure mode	Single anchor
Steel strength in tension	$\phi N_{sa} \geq N_{ua}$
Pullout strength in tension	$\phi N_{k,ug} \geq N_{ua}$
Steel strength in shear	$\phi V_{sa} \geq V_{ua}$
Anchorage strength in shear	$\phi V_{s,ug} \geq V_{ua}$
Masonry crushing strength in shear	$\phi V_{mc,ug} \geq V_{ua}$

TABLE 1D — REQUIRED STRENGTH OF ANCHORS IN CLAY BRICK

Failure mode	Single anchor
Steel strength in tension	$\phi N_{sa} \geq N_{ua}$
Pullout strength in tension	$\phi N_{k,br} \geq N_{ua}$
Steel strength in shear	$\phi V_{sa} \geq V_{ua}$
Anchorage strength in shear	$\phi V_{s,br} \geq V_{ua}$
Masonry crushing strength in shear	$\phi V_{mc,br} \geq V_{ua}$

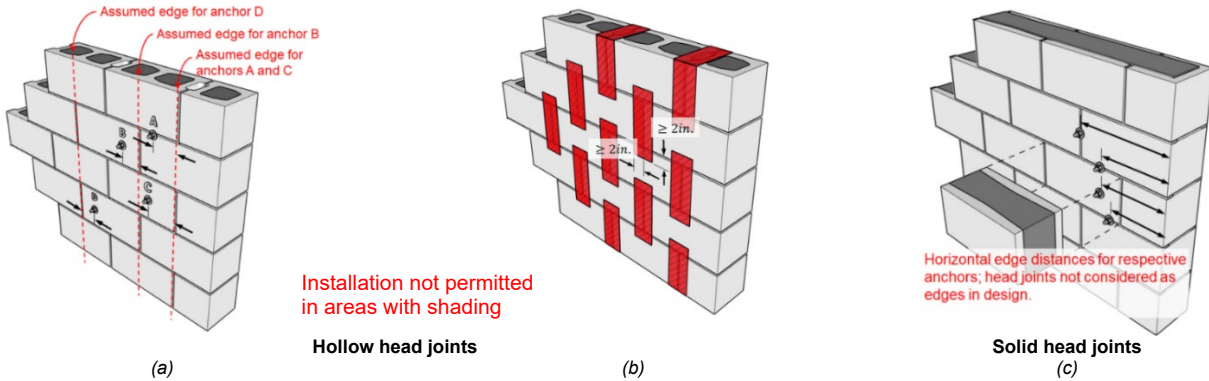

Installation not permitted in areas with shading

Hollow head joints

Solid head joints

FIGURE 1—(a) Edge distance considerations in fully grouted CMU construction with hollow head joints, (b) exclusion zones in fully grouted construction with hollow head joints, and (c) edge distance considerations in fully grouted CMU construction with solid head joints. Note: dimensions to upper and lower edges omitted for clarity.



TABLE 2 — STEEL DESIGN INFORMATION FOR FRACTIONAL THREADED ROD¹

DESIGN INFORMATION		Symbol	Units	Nominal rod diameter (in.)					
				1/4	5/16	3/8	1/2	5/8	3/4
Rod O.D.		<i>d</i>	in. (mm)	0.250 (6.4)	0.313 (7.9)	0.375 (9.5)	0.500 (12.7)	0.625 (15.9)	0.750 (19.1)
Rod effective cross-sectional area		<i>A_{se}</i>	in. ² (mm ²)	0.031 (20)	0.052 (34)	0.0775 (50)	0.1419 (92)	0.2260 (146)	0.3345 (216)
ISO 898-1 Class 5.8	Nominal strength as governed by steel strength	<i>N_{sa}</i>	lb (kN)	-	-	5,620 (25.0)	10,290 (45.8)	16,385 (72.9)	24,250 (107.9)
		<i>V_{sa}</i>	lb (kN)	-	-	3,370 (15.0)	6,175 (27.5)	9,830 (43.7)	14,550 (64.7)
	Reduction for seismic shear	<i>α_{V,seis}</i>	-	0.70					
	Strength reduction factor <i>φ</i> for tension ²	<i>φ</i>	-	0.65					
	Strength reduction factor <i>φ</i> for shear ²	<i>φ</i>	-	0.60					
ASTM A193 B7	Nominal strength as governed by steel strength	<i>N_{sa}</i>	lb (kN)	-	-	9,685 (43.1)	17,735 (78.9)	28,250 (125.7)	41,810 (186.0)
		<i>V_{sa}</i>	lb (kN)	-	-	5,810 (25.9)	10,640 (47.3)	16,950 (75.4)	25,085 (111.6)
	Reduction for seismic shear	<i>α_{V,seis}</i>	-	0.70					
	Strength reduction factor <i>φ</i> for tension ²	<i>φ</i>	-	0.75					
	Strength reduction factor <i>φ</i> for shear ²	<i>φ</i>	-	0.65					
ASTM A307 Gr. A	Nominal strength as governed by steel strength	<i>N_{sa}</i>	lb (kN)	1,910 (8.5)	3,070 (13.7)	-	-	-	-
		<i>V_{sa}</i>	lb (kN)	1,145 (5.1)	1,840 (8.2)	-	-	-	-
	Reduction for seismic shear	<i>α_{V,seis}</i>	-	0.60					
	Strength reduction factor <i>φ</i> for tension ²	<i>φ</i>	-	0.65					
	Strength reduction factor <i>φ</i> for shear ²	<i>φ</i>	-	0.60					
ASTM F1554 Gr. 36	Nominal strength as governed by steel strength	<i>N_{sa}</i>	lb (kN)	-	-	-	8,230 (36.6)	13,110 (58.3)	19,400 (86.3)
		<i>V_{sa}</i>	lb (kN)	-	-	-	4,940 (22.0)	7,865 (35.0)	11,640 (51.8)
	Reduction for seismic shear	<i>α_{V,seis}</i>	-	0.60					
	Strength reduction factor <i>φ</i> for tension ²	<i>φ</i>	-	0.75					
	Strength reduction factor <i>φ</i> for shear ²	<i>φ</i>	-	0.65					
ASTM F1554 Gr. 55	Nominal strength as governed by steel strength	<i>N_{sa}</i>	lb (kN)	-	-	-	10,645 (47.4)	16,950 (75.4)	25,090 (111.6)
		<i>V_{sa}</i>	lb (kN)	-	-	-	6,385 (28.4)	10,170 (45.2)	15,055 (67.0)
	Reduction for seismic shear	<i>α_{V,seis}</i>	-	0.70					
	Strength reduction factor <i>φ</i> for tension ²	<i>φ</i>	-	0.75					
	Strength reduction factor <i>φ</i> for shear ²	<i>φ</i>	-	0.65					
ASTM F1554 Gr. 105	Nominal strength as governed by steel strength	<i>N_{sa}</i>	lb (kN)	-	-	-	17,740 (78.9)	28,250 (125.7)	41,815 (186.0)
		<i>V_{sa}</i>	lb (kN)	-	-	-	10,645 (47.4)	16,950 (75.4)	25,090 (111.6)
	Reduction for seismic shear	<i>α_{V,seis}</i>	-	0.70					
	Strength reduction factor <i>φ</i> for tension ²	<i>φ</i>	-	0.75					
	Strength reduction factor <i>φ</i> for shear ²	<i>φ</i>	-	0.65					
ASTM F993, CW Stainless	Nominal strength as governed by steel strength	<i>N_{sa}</i>	lb (kN)	-	-	7,750 (34.5)	14,190 (63.1)	22,600 (100.5)	28,435 (126.5)
		<i>V_{sa}</i>	lb (kN)	-	-	4,650 (20.7)	8,515 (37.9)	13,560 (60.3)	17,060 (75.9)
	Reduction for seismic shear	<i>α_{V,seis}</i>	-	0.70					
	Strength reduction factor <i>φ</i> for tension ²	<i>φ</i>	-	0.65					
	Strength reduction factor <i>φ</i> for shear ²	<i>φ</i>	-	0.60					

For SI: 1 inch = 25.4 mm, 1 ft-lb = 1.356 Nm.

¹Values provided for common rod material types are based on specified strengths and calculated in accordance with ACI 318-19 Eq. 17.6.1.2 and Eq. 17.7.1.2b. Nuts and washers must be appropriate for the rod.

²The tabulated value of *φ* applies when the LRFD load combinations of ASCE 7 are used.



TABLE 3 — STEEL DESIGN INFORMATION FOR FRACTIONAL REINFORCING BARS¹

DESIGN INFORMATION		Symbol	Units	Nominal Reinforcing bar size (Rebar)			
				#3	#4	#5	#6
Nominal bar diameter		<i>d</i>	in. (mm)	0.375 (9.5)	0.500 (12.7)	0.625 (15.9)	0.750 (19.1)
Bar effective cross-sectional area		<i>A_{se}</i>	in. ² (mm ²)	0.11 (71)	0.2 (129)	0.31 (200)	0.44 (284)
ASTM A615 Grade 40	Nominal strength as governed by steel strength	<i>N_{sa}</i>	lb (kN)	6,600 (29.4)	12,000 (53.4)	18,600 (82.7)	26,400 (117.4)
		<i>V_{sa}</i>	lb (kN)	3,960 (17.6)	7,200 (32.0)	11,160 (49.6)	15,840 (70.5)
	Reduction for seismic shear	<i>α_{V,seis}</i>	-	0.70			
	Strength reduction factor <i>φ</i> for tension ²	<i>φ</i>	-	0.65			
	Strength reduction factor <i>φ</i> for shear ²	<i>φ</i>	-	0.60			
ASTM A615 Grade 60	Nominal strength as governed by steel strength	<i>N_{sa}</i>	lb (kN)	8,800 (39.1)	16,000 (71.2)	24,800 (110.3)	35,200 (156.6)
		<i>V_{sa}</i>	lb (kN)	5,280 (23.5)	9,600 (42.7)	14,880 (66.2)	21,120 (93.9)
	Reduction for seismic shear	<i>α_{V,seis}</i>	-	0.70			
	Strength reduction factor <i>φ</i> for tension ²	<i>φ</i>	-	0.65			
	Strength reduction factor <i>φ</i> for shear ²	<i>φ</i>	-	0.60			
ASTM A706 Grade 60	Nominal strength as governed by steel strength	<i>N_{sa}</i>	lb (kN)	8,800 (39.1)	16,000 (71.2)	24,800 (110.3)	35,200 (156.6)
		<i>V_{sa}</i>	lb (kN)	5,280 (23.5)	9,600 (42.7)	14,880 (66.2)	21,120 (94.0)
	Reduction for seismic shear	<i>α_{V,seis}</i>	-	0.70			
	Strength reduction factor <i>φ</i> for tension ²	<i>φ</i>	-	0.75			
	Strength reduction factor <i>φ</i> for shear ²	<i>φ</i>	-	0.65			

For **SI**: = 1 inch = 25.4 mm, 1 ft-lb = 1.356 Nm.

¹Values provided for common rod material types are based on specified strengths and calculated in accordance with ACI 318-19 Eq. 17.6.1.2 and Eq. 17.7.1.2b.

²The tabulated value of *φ* applies when the LRFD load combinations of ASCE 7 are used.



TABLE 4A — STEEL DESIGN INFORMATION FOR FRACTIONAL HIS-(R)N THREADED INSERTS¹

DESIGN INFORMATION		Symbol	Units	Nominal Bolt/Cap Screw Diameter (in.)	
				3/8	1/2
HIS insert O.D.		<i>d</i>	in. (mm)	0.65 (16.5)	0.81 (20.5)
HIS insert length		<i>L</i>	in. (mm)	4.33 (110)	4.92 (125)
Bar effective cross-sectional area		<i>A_{se}</i>	in ² (mm ²)	0.0775 (50)	0.1419 (92)
HIS insert effective cross-sectional area		<i>A_{insert}</i>	in. (mm)	0.178 (115)	0.243 (157)
ASTM A193 B7	Nominal steel strength – ASTM A193 B7 ³ bolt/cap screw	<i>N_{sa}</i>	lb (kN)	9,690 (43.1)	17,740 (78.9)
		<i>V_{sa}</i>	lb (kN)	5,815 (25.9)	10,645 (47.3)
	Nominal steel strength – HIS-N insert	<i>N_{sa}</i>	lb (kN)	12,650 (56.3)	16,195 (72.0)
	Reduction for seismic shear	<i>α_{V,seis}</i>	-	0.70	
	Strength reduction factor <i>φ</i> for tension ²	<i>φ</i>	-	0.65	
	Strength reduction factor <i>φ</i> for shear ²	<i>φ</i>	-	0.60	
ASTM A193 Grade B8M SS	Nominal steel strength – ASTM A193 Grade B8M SS bolt/cap screw	<i>N_{sa}</i>	lb (kN)	8,525 (37.9)	15,610 (69.4)
		<i>V_{sa}</i>	lb (kN)	5,115 (22.8)	9,365 (41.7)
	Nominal steel strength – HIS-RN insert	<i>N_{sa}</i>	lb (kN)	17,165 (76.3)	23,430 (104.2)
	Reduction for seismic shear	<i>α_{V,seis}</i>	-	0.70	
	Strength reduction factor <i>φ</i> for tension ²	<i>φ</i>	-	0.65	
	Strength reduction factor <i>φ</i> for shear ²	<i>φ</i>	-	0.60	

For **SI**: = 1 inch = 25.4 mm, 1 ft-lb = 1.356 Nm.

¹Values provided for common rod material types are based on specified strengths and calculated in accordance with ACI 318-19 Eq. 17.6.1.2 and Eq. 17.7.1.2b. Nuts and washers must be appropriate for the rod.

²The tabulated value of *φ* applies when the LRFD load combinations of ASCE 7 are used.

³For the calculation of the design steel strength in tension and shear for the bolt or screw, the *φ* factor for ductile steel failure according to ACI 318-19 17.5.3 can be used.

TABLE 4B — STEEL DESIGN INFORMATION FOR FRACTIONAL HIT-IC THREADED INSERTS¹

DESIGN INFORMATION		Symbol	Units	Nominal Bolt/Cap Screw Diameter (in.)		
				5/16	3/8	1/2
HIT-IC insert O.D.		d	in. (mm)	0.43 (11.0)	0.53 (13.5)	0.63 (16.0)
Bar effective cross-sectional area		A_{se}	in ² (mm ²)	0.0524 (34)	0.0775 (50)	0.1419 (92)
HIT-IC insert effective cross-sectional area		A_{insert}	in ² (mm ²)	0.0593 (38)	0.0877 (57)	0.2122 (137)
ASTM A193 B7	Nominal steel strength – ASTM A193 Grade B7 ³ bolt/cap screw	N_{sa}	lb (kN)	6,550 (29.1)	9,690 (43.1)	17,740 (78.9)
		V_{sa}	lb (kN)	3,930 (17.5)	5,815 (25.9)	10,645 (47.3)
	Nominal steel strength – HIT-IC insert	N_{sa}	lb (kN)	4,215 (18.7)	6,230 (27.7)	15,080 (67.1)
	Reduction for seismic shear	$\alpha_{V,seis}$	-	0.70		
	Strength reduction factor ϕ for tension ²	ϕ	-	0.65		
	Strength reduction factor ϕ for shear ²	ϕ	-	0.60		

For **SI**: = 1 inch = 25.4 mm, 1 ft-lb = 1.356 Nm.

¹Values provided for common rod material types are based on specified strengths and calculated in accordance with ACI 318-19 Eq. 17.6.1.2 and Eq. 17.7.1.2b. Nuts and washers must be appropriate for the rod.

²The tabulated value of ϕ applies when the LRFD load combinations of ASCE 7 are used.

³For the calculation of the design steel strength in tension and shear for the bolt or screw, the ϕ factor for ductile steel failure according to ACI 318-19 17.5.3 can be used.

TABLE 5 — HIT-HY 270 INSTALLATION INFORMATION FOR THREADED ROD, REBAR, AND HILTI HIS-(R)N ANCHORS- FULLY GROUTED CMU CONSTRUCTION, FACE AND TOP OF WALL

INSTALLATION INFORMATION	Symbol	Units	Nominal Rod Diameter / Rebar Size			
			3/8" or #3	1/2" or #4	5/8" or #5	3/4" or #6
Drill Bit Diameter - Threaded Rod	d_o	in.	7/16	9/16	3/4	7/8
Drill Bit Diameter - Rebar	d_o	in.	1/2	5/8	3/4	7/8
Drill Bit Diameter – HIS N	d_o	in.	11/16	7/8	N/A	N/A
Maximum Tightening Torque	T_{inst}	ft-lbs.	6	7.5	7.5	10
Minimum Embedment Depth – Threaded Rod & Rebar	$h_{ef,min}$	in.	2-3/8	2-3/4	3-1/8	3-1/2
Minimum Embedment Depth – HIS-(R)N	$h_{ef,min}$	in.	4-3/8	5	N/A	N/A
Maximum Embedment Depth	$h_{ef,max}$	in.	7-1/2	10	10	10
Minimum Masonry Thickness ¹	h_{min}	in.	7-5/8			
Minimum Edge Distance ² – Face of Wall	c_{min}	in.	$6d_a$			
Minimum Anchor Spacing – Face of Wall	s_{min}	in.	$6d_a$			
Minimum Edge Distance ² – Top of Wall	$c_{min,tow}$	in.	N/A	1-3/4 ³	1-3/4	2-3/4 ⁴
Minimum Anchor Spacing – Top of Wall	$s_{min,tow}$	in.	N/A	8 ³	8	8 ⁴

For **SI**: 1 inch = 25.4 mm, 1 ft-lb = 1.356 Nm.

¹Maximum embedment for installation into the face of 7-5/8" CMU wall is 6-1/8". Maximum embedment for installation into the face of 9-5/8" CMU wall is 8".

²The minimum distance from the center of an anchor to the centerline of a hollow head joint (vertical mortar joint) is 2", as shown in [Figure 1](#).

³1/2" HIS-(R)N is not applicable for top of wall applications.

⁴#6 rebar is not applicable for top of wall applications.

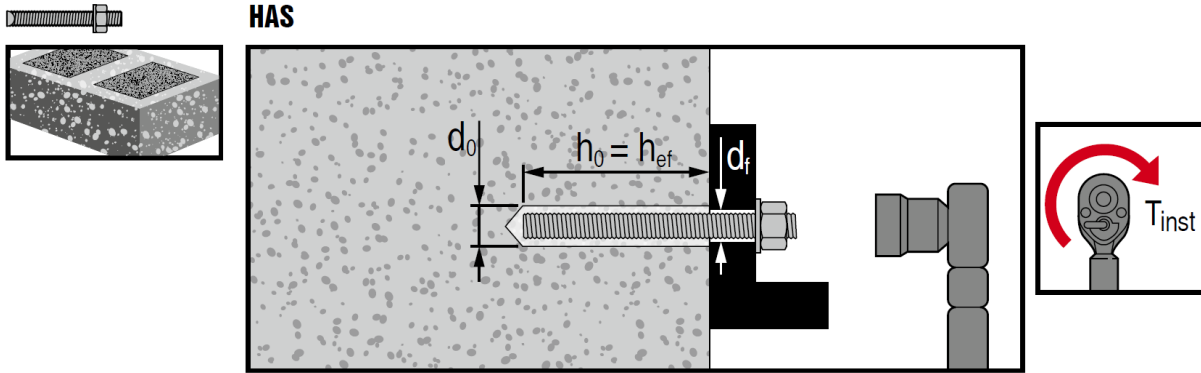

FIGURE 2—Threaded Rod Installation in Fully Grouted CMU

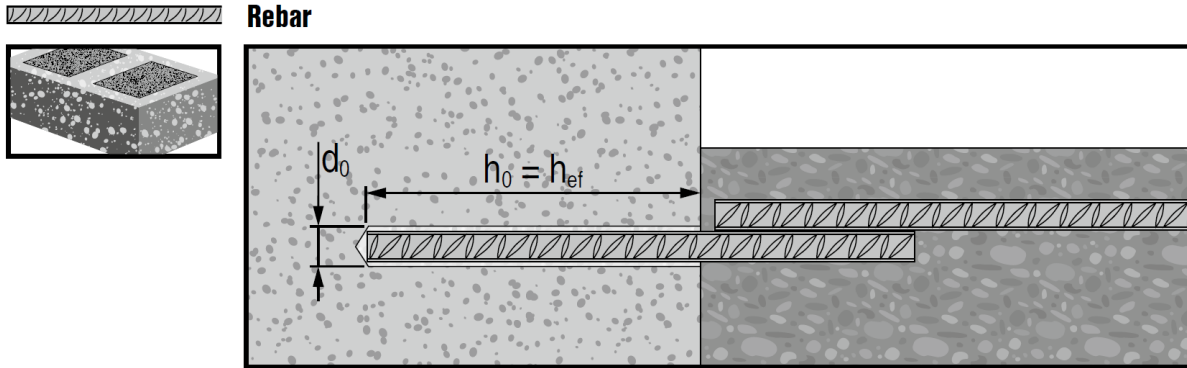

FIGURE 3—Rebar Installation in Fully Grouted CMU

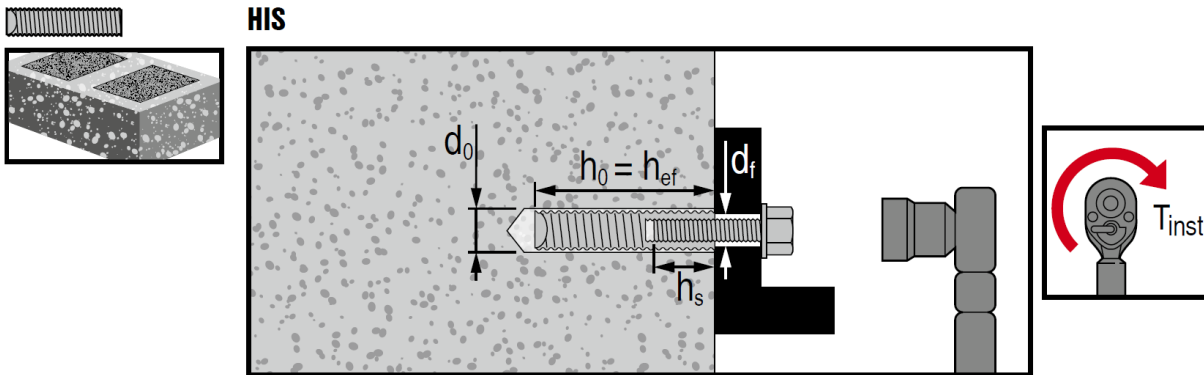

FIGURE 4—HIS-(R)N Installation in Fully Grouted CMU

TABLE 6 — HIT-HY 270 MASONRY BREAKOUT AND SHEAR CRUSHING DESIGN INFORMATION FOR THREADED ROD, REBAR, AND HILTI HIS-(R)N ANCHORS

DESIGN INFORMATION	Symbol	Units	Nominal Rod Diameter / Rebar Size			
			3/8" or #3	1/2" or #4	5/8" or #5	3/4" or #6
Nominal Diameter	d_a	in.	3/8	1/2	5/8	3/4
Minimum Embedment Depth – Threaded Rod & Rebar	$h_{ef,min}$	in.	2-3/8	2-3/4	3-1/8	3-1/2
Minimum Embedment Depth – HIS-(R)N	$h_{ef,min}$	in.	4-3/8	5	N/A	N/A
Effectiveness Factor for Cracked Masonry	$k_{m,cr}$	-	12			
Effectiveness Factor for Uncracked Masonry	$k_{m,uncr}$	-	17			
Strength Reduction Factor - Masonry Breakout Failure in Tension ¹	ϕ	-	0.65			
Strength Reduction Factor - Masonry Breakout Failure in Shear ¹	ϕ	-	0.70			
Strength Reduction Factor - Shear Crushing ¹	ϕ	-	0.50			

For SI: 1 inch = 25.4 mm, 1 ft-lb = 1.356 Nm.

¹The tabulated value of ϕ applies when the LRFD load combinations of ASCE 7 are used.

TABLE 7 — HIT-HY 270 BOND STRENGTH DESIGN INFORMATION FOR THREADED ROD ANCHORS - FULLY GROUTED CMU CONSTRUCTION, FACE OF WALL¹

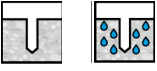
DESIGN INFORMATION		Symbol	Units	Nominal Rod Diameter			
				3/8"	1/2"	5/8"	3/4"
Minimum Embedment		$h_{ef,min}$	in.	2-3/8	2-3/4	3-1/8	3-1/2
Maximum Embedment		$h_{ef,max}$	in.	7-1/2	10	10	10
Temperature Range A ²	Characteristic Bond Strength in cracked masonry	$T_{k,cr}$	psi	335	300	245	145
	Characteristic Bond Strength in uncracked masonry	$T_{k,uncr}$	psi	440	435	445	200
Temperature Range B ²	Characteristic Bond Strength in cracked masonry	$T_{k,cr}$	psi	305	275	225	130
	Characteristic Bond Strength in uncracked masonry	$T_{k,uncr}$	psi	400	395	405	185
Dry and Water Saturated Installation Conditions ³		Anchor Category	-	1	2	2	2
		ϕ	-	0.65	0.55	0.55	0.55
Strength Reduction Factor for Saturated Masonry Tension ⁴		$\alpha_{N,sat}$	-	1.00	1.00	0.93	0.93
Strength Reduction Factor for Sustained Tension ⁵		$\alpha_{N,sust}$	-	0.80	0.80	0.80	0.80
Strength Reduction Factor for Top of Wall Tension ⁶		$\alpha_{N,tow}$	-	N/A	0.58	0.56	1.00
Strength Reduction Factor for Seismic Tension ⁷		$\alpha_{N,seis}$	-	0.98	0.87	0.88	0.98

For **SI**: 1 inch = 25.4 mm, 1 ft-lb = 1.356 Nm.

¹Bond strength values shown are for fully grouted CMU construction with lightweight, medium-weight, or normal-weight masonry units, having a net compressive strength of $f'_m = 1,500$ psi.

²Temperature Range A: Maximum short term temperature = 130°F, Maximum long term temperature = 110°F.

Temperature Range B: Maximum short term temperature = 176°F, Maximum long term temperature = 110°F.

Short term masonry temperatures are those that occur over short intervals (diurnal cycling). Long term temperatures are roughly constant over significant periods of time.

³The tabulated values of ϕ , apply when the LRFD load combinations of ASCE 7 are used.

⁴For anchors installed in water saturated masonry, the bond strength values must be multiplied by $\alpha_{N,sat}$.

⁵For anchors designed for sustained tensile loading, the bond strength values must be multiplied by $\alpha_{N,sust}$.

⁶For anchors installed in the top of a CMU wall, the bond strength values must be multiplied by $\alpha_{N,tow}$.

⁷For anchors installed in regions assigned to Seismic Design Category C, D, E, or F, the bond strength values must be multiplied by $\alpha_{N,seis}$.

TABLE 8 — HIT-HY 270 BOND STRENGTH DESIGN INFORMATION FOR REBAR ANCHORS - FULLY GROUTED CMU CONSTRUCTION, FACE OF WALL¹

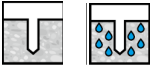
DESIGN INFORMATION		Symbol	Units	Nominal Reinforcing bar size (Rebar)			
				#3	#4	#5	#6
Minimum Embedment		$h_{ef,min}$	in.	2-3/8	2-3/4	3-1/8	3-1/2
Maximum Embedment		$h_{ef,max}$	in.	7-1/2	10	10	10
Temperature Range A ²	Characteristic Bond Strength in cracked masonry	$T_{k,cr}$	psi	340	205	275	170
	Characteristic Bond Strength in uncracked masonry	$T_{k,uncr}$	psi	535	435	465	400
Temperature Range B ²	Characteristic Bond Strength in cracked masonry	$T_{k,cr}$	psi	310	185	255	155
	Characteristic Bond Strength in uncracked masonry	$T_{k,uncr}$	psi	490	400	425	365
Dry and Water Saturated Installation Conditions ³		Anchor Category	-	1	2	2	2
		ϕ	-	0.65	0.55	0.55	0.55
Strength Reduction Factor for Saturated Masonry Tension ⁴		$\alpha_{N,sat}$	-	1.00	1.00	0.93	0.93
Strength Reduction Factor for Sustained Tension ⁵		$\alpha_{N,sust}$	-	1.00	1.00	1.00	1.00
Strength Reduction Factor for Top of Wall Tension ⁶		$\alpha_{N,tow}$	-	N/A	0.72	0.42	N/A
Strength Reduction Factor for Seismic Tension ⁷		$\alpha_{N,seis}$	-	0.89	0.98	0.98	0.71

For **SI**: 1 inch = 25.4 mm, 1 ft-lb = 1.356 Nm.

¹Bond strength values shown are for fully grouted CMU construction with lightweight, medium-weight, or normal-weight masonry units, having a net compressive strength of $f'_m = 1,500$ psi.

²Temperature Range A: Maximum short term temperature = 130°F, Maximum long term temperature = 110°F.

Temperature Range B: Maximum short term temperature = 176°F, Maximum long term temperature = 110°F.

Short term masonry temperatures are those that occur over short intervals (diurnal cycling). Long term temperatures are roughly constant over significant periods of time.

³The tabulated values of ϕ , apply when the LRFD load combinations of ASCE 7 are used.

⁴For anchors installed in water saturated masonry, the bond strength values must be multiplied by $\alpha_{N,sat}$.

⁵For anchors designed for sustained tensile loading, the bond strength values must be multiplied by $\alpha_{N,sust}$.

⁶For anchors installed in the top of a CMU wall, the bond strength values must be multiplied by $\alpha_{N,tow}$.

⁷For anchors installed in regions assigned to Seismic Design Category C, D, E or F, the bond strength values must be multiplied by $\alpha_{N,seis}$.

TABLE 9 — HIT-HY 270 BOND STRENGTH DESIGN INFORMATION FOR HILTI HIS-(R)N ANCHORS - FULLY GROUTED CMU CONSTRUCTION, FACE OF WALL¹

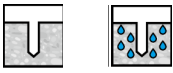
DESIGN INFORMATION		Symbol	Units	Nominal Rod Diameter	
				3/8"	1/2"
Minimum Embedment		$h_{ef,min}$	in.	4-3/8	5
Temperature Range A ²	Characteristic Bond Strength in cracked masonry	$T_{k,cr}$	psi	140	90
	Characteristic Bond Strength in uncracked masonry	$T_{k,ungr}$	psi	295	275
Temperature Range B ²	Characteristic Bond Strength in cracked masonry	$T_{k,cr}$	psi	125	80
	Characteristic Bond Strength in uncracked masonry	$T_{k,ungr}$	psi	270	250
Dry and Water Saturated Installation Conditions ³		Anchor Category	-	2	2
		ϕ	-	0.55	0.55
Strength Reduction Factor for Saturated Masonry Tension ⁴		$\alpha_{N,sat}$	-	0.93	0.93
Strength Reduction Factor for Sustained Tension ⁵		$\alpha_{N,sust}$	-	1.00	1.00
Strength Reduction Factor for Top of Wall Tension ⁶		$\alpha_{N,tow}$	-	N/A	N/A
Strength Reduction Factor for Seismic Tension ⁷		$\alpha_{N,seis}$	-	0.55	0.65

For SI: 1 inch = 25.4 mm, 1 ft-lb = 1.356 Nm.

¹Bond strength values shown are for fully grouted CMU construction with lightweight, medium-weight, or normal-weight masonry units, having a net compressive strength of $f'_m = 1,500$ psi.

²Temperature Range A: Maximum short term temperature = 130°F, Maximum long term temperature = 110°F.

Temperature Range B: Maximum short term temperature = 176°F, Maximum long term temperature = 110°F.

Short term masonry temperatures are those that occur over short intervals (diurnal cycling). Long term temperatures are roughly constant over significant periods of time.

³The tabulated values of ϕ , apply when the LRFD load combinations of ASCE 7 are used.

⁴For anchors installed in water saturated masonry, the bond strength values must be multiplied by $\alpha_{N,sat}$.

⁵For anchors designed for sustained tensile loading, the bond strength values must be multiplied by $\alpha_{N,sust}$.

⁶For anchors installed in the top of a CMU wall, the bond strength values must be multiplied by $\alpha_{N,tow}$.

⁷For anchors installed in regions assigned to Seismic Design Category C, D, E or F, the bond strength values must be multiplied by $\alpha_{N,seis}$.

TABLE 10 — HIT-HY 270 INSTALLATION INFORMATION FOR THREADED ROD AND HILTI HIT-IC - UNGROUTED CMU CONSTRUCTION, FACE OF WALL

INSTALLATION INFORMATION		Symbol	Units	Nominal Rod Diameter			
				1/4"	5/16"	3/8"	1/2"
Drill Bit Diameter - Threaded Rod		d_o	in.	1/2	5/8	5/8	11/16
Drill Bit Diameter - HIT-IC		d_o	in.	N/A	5/8	7/8	7/8
Maximum Tightening Torque		T_{inst}	ft-lbs.	2.2	2.2	3	4.5
Minimum Embedment Depth - Threaded Rod & HIT-IC		$h_{ef,min}$	in.	2	2	2	2
Minimum Masonry Thickness		h_{min}	in.	7-5/8			
Critical Edge Distance (Tension)		$c_{cr,N}$	in.	4			
Minimum Edge Distance (Tension) ¹		$c_{min,N}$	in.	2			
Multiplier at Minimum Edge Distance (Tension)		-	-	0.80			
Threaded Rod	Critical Edge Distance (Shear)	$c_{cr,V}$	in.	3	3-3/4	4-1/2	6
	Minimum Edge Distance (Shear) ¹	$c_{min,V}$	in.	1-1/2	1-7/8	2-1/4	3
HIT-IC	Critical Edge Distance (Shear)	$c_{cr,V}$	in.	N/A	5.16	6.36	7.56
	Minimum Edge Distance (Shear) ¹	$c_{min,V}$	in.	N/A	2-5/8	3-1/4	3-7/8
Multiplier at Minimum Edge Distance (Shear)		-	-	0.50			
Minimum Anchor Spacing		s_{min}	in.	8			

For SI: 1 inch = 25.4 mm, 1 ft-lb = 1.356 Nm.

¹The minimum distance from the center of an anchor to the centerline of a head joint (vertical mortar joint) is 2", as shown in [Figure 1](#).

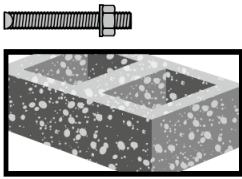

HAS

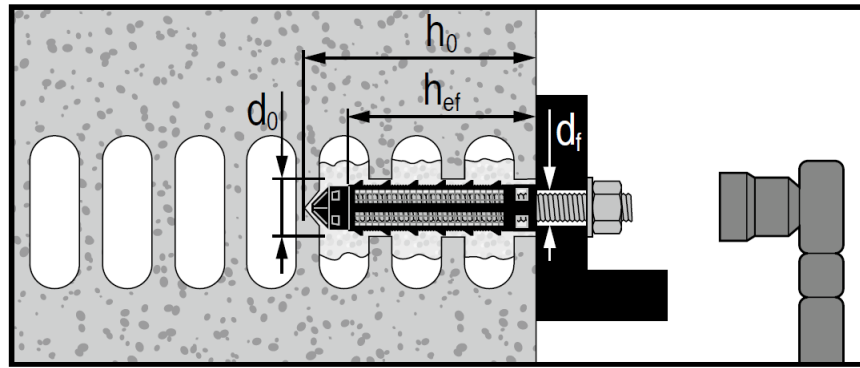
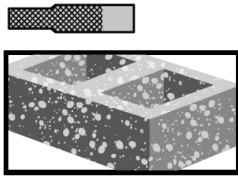

FIGURE 5—Threaded Rod Installation in UngROUTED CMU



HIT-IC

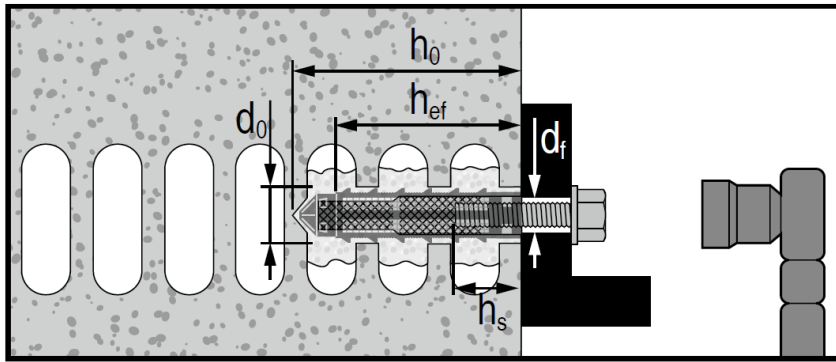

FIGURE 6—HIT-IC Installation in UngROUTED CMU

TABLE 11 — HIT-HY 270 BOND STRENGTH DESIGN INFORMATION FOR THREADED ROD ANCHORS - UNGROUTED CMU CONSTRUCTION, FACE OF WALL¹

DESIGN INFORMATION	Symbol	Units	Nominal Rod Diameter				
			1/4"	5/16"	3/8"	1/2"	
Minimum Embedment	$h_{ef,min}$	in.	2	2	2	2	
Temperature Range A ²	Characteristic Bond Strength in Cracked Masonry	$N_{k,cr}$	lb.	195	320	320	325
	Characteristic Bond Strength in Uncracked Masonry	$N_{k,uncr}$	lb.	390	645	640	650
Temperature Range B ²	Characteristic Bond Strength in Cracked Masonry	$N_{k,cr}$	lb.	195	320	320	325
	Characteristic Bond Strength in Uncracked Masonry	$N_{k,uncr}$	lb.	390	645	640	650
Dry and Water Saturated Installation Conditions ³	Anchor Category	-	2	2	2	2	
		ϕ	-	0.55	0.55	0.55	0.55
Strength Reduction Factor for Saturated Masonry Tension ⁴	$\alpha_{N,sat}$	-	1.00	1.00	1.00	1.00	
Strength Reduction Factor for Sustained Tension ⁵	$\alpha_{N,sust}$	-	0.90	0.90	0.90	0.90	
Characteristic Anchorage Strength in Cracked Masonry	$V_{s,cr}$	lb.	195	320	320	325	
Characteristic Anchorage Strength in Uncracked Masonry	$V_{s,uncr}$	lb.	390	645	640	650	

For SI: 1 inch = 25.4 mm, 1 ft-lb = 1.356 Nm.

¹Strength values shown are for ungrouted CMU construction with lightweight, medium-weight, or normal-weight masonry units, having a net compressive strength of $f_m = 1,500$ psi.

²Temperature Range A: Maximum short term temperature = 130°F, Maximum long term temperature = 110°F.

Temperature Range B: Maximum short term temperature = 176°F, Maximum long term temperature = 110°F.

Short term masonry temperatures are those that occur over short intervals (diurnal cycling). Long term temperatures are roughly constant over significant periods of time.

³The tabulated values of ϕ , apply when the LRFD load combinations of ASCE 7 are used.

⁴For anchors installed in water saturated masonry, the bond strength values must be multiplied by $\alpha_{N,sat}$.

⁵For anchors designed for sustained tensile loading, the bond strength values must be multiplied by $\alpha_{N,sust}$.

TABLE 12 — HIT-HY 270 BOND STRENGTH DESIGN INFORMATION FOR HIT-IC ANCHORS - UNGROUTED CMU CONSTRUCTION, FACE OF WALL¹

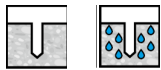
DESIGN INFORMATION		Symbol	Units	Nominal Rod Diameter		
				5/16"	3/8"	1/2"
Minimum Embedment		$h_{ef,min}$	in.	2	2	2
Temperature Range A ²	Characteristic Strength in Cracked Masonry	$N_{k,cr}$	lb.	335	330	330
	Characteristic Strength in Uncracked Masonry	$N_{k,uncr}$	lb.	665	655	665
Temperature Range B ²	Characteristic Strength in Cracked Masonry	$N_{k,cr}$	lb.	335	330	330
	Characteristic Strength in Uncracked Masonry	$N_{k,uncr}$	lb.	665	655	665
Dry and Water Saturated Installation Conditions ³		Anchor Category	-	1	2	2
		ϕ	-	0.65	0.55	0.55
Strength Reduction Factor for Saturated Masonry Tension ⁴		$\alpha_{N,sat}$	-	1.00	1.00	0.93
Strength Reduction Factor for Sustained Tension ⁵		$\alpha_{N,sust}$	-	0.90	0.90	0.90
Characteristic Anchorage Strength in Cracked Masonry		$V_{s,cr}$	lb.	335	330	330
Characteristic Anchorage Strength in Uncracked Masonry		$V_{s,uncr}$	lb.	665	655	665

For SI: 1 inch = 25.4 mm, 1 ft-lb = 1.356 Nm.

¹Strength values shown are for ungrouted CMU construction with lightweight, medium-weight, or normal-weight masonry units, having a net compressive strength of $f_m = 1,500$ psi.

²Temperature Range A: Maximum short term temperature = 130°F, Maximum long term temperature = 110°F.

Temperature Range B: Maximum short term temperature = 176°F, Maximum long term temperature = 110°F.

Short term masonry temperatures are those that occur over short intervals (diurnal cycling). Long term temperatures are roughly constant over significant periods of time.

³The tabulated values of ϕ , apply when the LRFD load combinations of ASCE 7 are used.

⁴For anchors installed in water saturated masonry, the bond strength values must be multiplied by $\alpha_{N,sat}$.

⁵For anchors designed for sustained tensile loading, the bond strength values must be multiplied by $\alpha_{N,sust}$.

TABLE 13 — HIT-HY 270 INSTALLATION INFORMATION FOR THREADED ROD AND HILTI HIT-IC – CLAY BRICK CONSTRUCTION, FACE OF WALL

INSTALLATION INFORMATION		Symbol	Units	Nominal Rod Diameter			
				1/4"	5/16"	3/8"	1/2"
Drill Bit Diameter – Threaded Rod		d_o	in.	1/2	5/8	5/8	11/16
Drill Bit Diameter – HIT-IC		d_o	in.	N/A	5/8	7/8	7/8
Maximum Tightening Torque		T_{inst}	ft-lbs.	2.2	2.2	3	4.5
Minimum Embedment Depth – Threaded Rod & HIT-IC		$h_{ef,min}$	in.	3-1/8	3-1/8	3-1/8	3-1/8
Minimum Masonry Thickness		h_{min}	in.	3-5/8			
Critical Edge Distance (Tension)		$c_{cr,N}$	in.	6-1/4			
Minimum Edge Distance (Tension)		$c_{min,N}$	in.	4			
Multiplier at Minimum Edge Distance (Tension)		-	-	0.80			
Threaded Rod	Critical Edge Distance (Shear)	$c_{cr,V}$	in.	3	3-3/4	4-1/2	6
	Minimum Edge Distance (Shear)	$c_{min,V}$	in.	1-1/2	1-7/8	2-1/4	3
HIT-IC	Critical Edge Distance (Shear)	$c_{cr,V}$	in.	N/A	5.16	6.36	7.56
	Minimum Edge Distance (Shear)	$c_{min,V}$	in.	N/A	2-5/8	3-1/4	3-7/8
Multiplier at Minimum Edge Distance (Shear)		-	-	0.50			
Minimum Anchor Spacing		s_{min}	in.	8			

For SI: 1 inch = 25.4 mm, 1 ft-lb = 1.356 Nm.

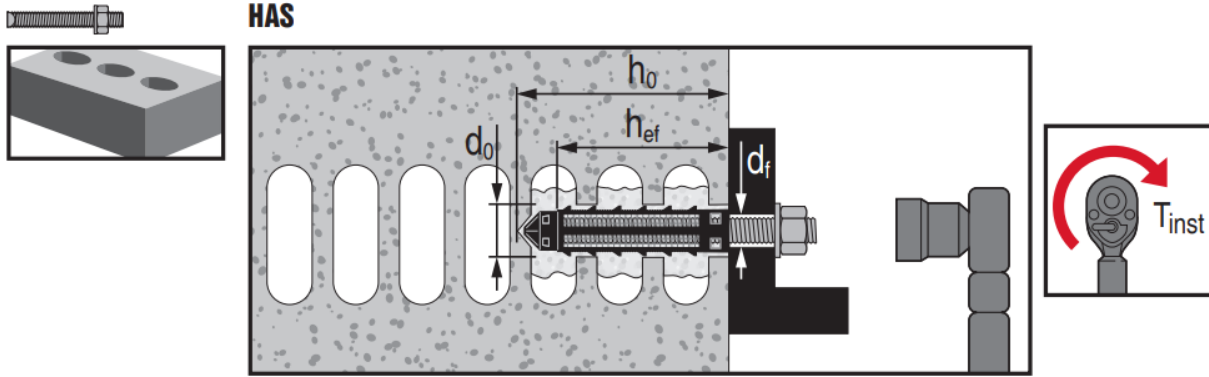

FIGURE 7—Threaded Rod Installation in Clay Brick

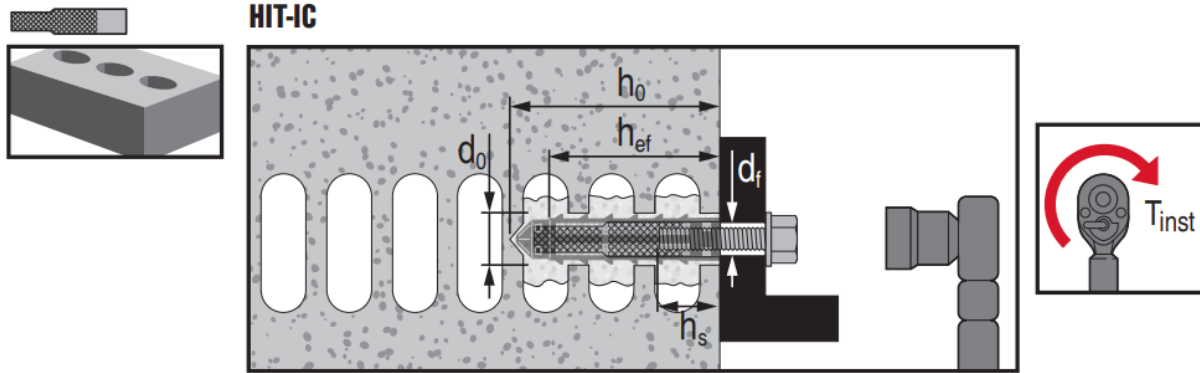



FIGURE 8—HIT-IC Installation in Clay Brick

TABLE 14 — HIT-HY 270 BOND STRENGTH DESIGN INFORMATION FOR THREADED ROD ANCHORS – CLAY BRICK CONSTRUCTION, FACE OF WALL¹

DESIGN INFORMATION		Symbol	Units	Nominal Rod Diameter			
				1/4"	5/16"	3/8"	1/2"
Minimum Embedment		$h_{ef,min}$	in.	3-1/8	3-1/8	3-1/8	3-1/8
Temperature Range A ²	Characteristic Bond Strength in Cracked Masonry	$N_{k,cr}$	lb.	230	360	360	510
	Characteristic Bond Strength in Uncracked Masonry	$N_{k,uncr}$	lb.	465	725	725	1,020
Temperature Range B ²	Characteristic Bond Strength in Cracked Masonry	$N_{k,cr}$	lb.	145	225	225	320
	Characteristic Bond Strength in Uncracked Masonry	$N_{k,uncr}$	lb.	290	455	455	640
Dry Installation Conditions ³	 Anchor Category	-	-	1	1	1	2
	ϕ	-	-	0.65	0.65	0.65	0.55
Water Saturated Installation Conditions ³	 Anchor Category	-	-	2	2	2	2
	ϕ	-	-	0.55	0.55	0.55	0.55
Strength Reduction Factor for Saturated Masonry Tension ⁴		$\alpha_{N,sat}$	-	0.57	0.57	0.57	0.71
Strength Reduction Factor for Sustained Tension ⁵		$\alpha_{N,sust}$	-	1.00	1.00	1.00	1.00
Characteristic Anchorage Strength in Cracked Masonry		$V_{s,cr}$	lb.	655	890	890	1,930
Characteristic Anchorage Strength in Uncracked Masonry		$V_{s,uncr}$	lb.	655	890	890	1,930

For SI: 1 inch = 25.4 mm, 1 ft-lb = 1.356 Nm.

¹Strength values shown are for clay brick construction having a net compressive strength of $f_m = 3,000$ psi.

²Temperature Range A: Maximum short term temperature = 130°F, Maximum long term temperature = 110°F.

Temperature Range B: Maximum short term temperature = 176°F, Maximum long term temperature = 110°F.



Short term masonry temperatures are those that occur over short intervals (diurnal cycling). Long term temperatures are roughly constant over significant periods of time.

³The tabulated values of ϕ , apply when the LRFD load combinations of ASCE 7 are used.

⁴For anchors installed in water saturated masonry, the bond strength values must be multiplied by $\alpha_{N,sat}$.

⁵For anchors designed for sustained tensile loading, the bond strength values must be multiplied by $\alpha_{N,sust}$.

TABLE 15 — HIT-HY 270 BOND STRENGTH DESIGN INFORMATION FOR HIT-IC ANCHORS – CLAY BRICK CONSTRUCTION, FACE OF WALL¹

DESIGN INFORMATION		Symbol	Units	Nominal Rod Diameter		
				5/16"	3/8"	1/2"
Minimum Embedment		$h_{ef,min}$	in.	3-1/8	3-1/8	3-1/8
Temperature Range A ²	Characteristic Strength in Cracked Masonry	$N_{k,cr}$	lb.	130	130	185
	Characteristic Strength in Uncracked Masonry	$N_{k,uncr}$	lb.	265	265	375
Temperature Range B ²	Characteristic Strength in Cracked Masonry	$N_{k,cr}$	lb.	85	85	115
	Characteristic Strength in Uncracked Masonry	$N_{k,uncr}$	lb.	165	165	235
Dry Installation Conditions ³		Anchor Category	-	1	2	2
		ϕ	-	0.65	0.55	0.55
Water Saturated Installation Conditions ³		Anchor Category	-	2	2	2
		ϕ	-	0.55	0.55	0.55
Strength Reduction Factor for Saturated Masonry Tension ⁴		$\alpha_{N,sat}$	-	0.57	0.57	0.71
Strength Reduction Factor for Sustained Tension ⁵		$\alpha_{N,sust}$	-	1.00	1.00	1.00
Characteristic Anchorage Strength in Cracked Masonry		$V_{s,cr}$	lb.	645	645	1,865
Characteristic Anchorage Strength in Uncracked Masonry		$V_{s,uncr}$	lb.	645	645	1,865

For SI: 1 inch = 25.4 mm, 1 ft-lb = 1.356 Nm.

¹Strength values shown are for clay brick construction having a net compressive strength of $f_m = 3,000$ psi.

²Temperature Range A: Maximum short term temperature = 130°F, Maximum long term temperature = 110°F.

Temperature Range B: Maximum short term temperature = 176°F, Maximum long term temperature = 110°F.

Short term masonry temperatures are those that occur over short intervals (diurnal cycling). Long term temperatures are roughly constant over significant periods of time.

³The tabulated values of ϕ , apply when the LRFD load combinations of ASCE 7 are used.

⁴For anchors installed in water saturated masonry, the bond strength values must be multiplied by $\alpha_{N,sat}$.

⁵For anchors designed for sustained tensile loading, the bond strength values must be multiplied by $\alpha_{N,sust}$.

TABLE 16— APPLICABLE SECTIONS OF THE IBC CODE UNDER EACH EDITION OF THE IBC AND IRC

IBC			
2024 IBC	2021 IBC	2018 IBC	2015 IBC
Section 1605.1		Section 1605.2 or 1605.3	
Section 1905.7		Section 1905.1.8	
	Chapter 21		
	Section 2103.2.1		
	Section 2103.3		
IRC			
2024 IRC	2021 IRC	2018 IRC	2015 IRC
	Section R301.1.3		
	Section R606.2.8		Section R606.2.7
	Section R606.2.12		Section R606.2.11

TABLE 17— APPLICABLE SECTIONS OF TMS 402 UNDER EACH EDITION OF THE IBC

2024 IBC	2021 IBC	2018 IBC	2015 IBC
TMS 402-22	TMS 402-16		TMS 402-13
Section 8.1.4	Section 8.1.3		Section 8.1.4
	Section 9.1.6		
Eq. 9-5	Eq. 9-7		



Hilti HIT-HY 270



graco.com
1-800-790-2195

English
Français
Español
Português

(A, B)

(A)

(B)

WARNING
Contains: methacrylates (A), dibenzoyl peroxide (B), boric acid (A), 4-tert-butylpyrocatechol (A)
 May cause an allergic skin reaction. (A,B) Causes serious eye irritation. (A) May damage fertility or the unborn child. (A) Very toxic to aquatic life with long lasting effects. (B) Harmful to aquatic life with long lasting effects. (A)

ICC
ESR
ICC ESR 4143
ICC ESR 4144



[F]	[°C]				
		t_{work}	t_{cure}		
23–32	-5...0	10 min	6 h		
33–41	1...5	10 min	4 h		
42–50	6...10	7 min	2.5 h		
51–68	11...20	4 min	1.5 h		
69–86	21...30	2 min	30 min		
87–104	31...40	1 min	20 min		

[F]	[°C]				
		t_{work}	t_{cure}		
41	5	10 min	4 h		
42–50	6...10	7 min	2.5 h		
51–68	11...20	4 min	1.5 h		
69–86	21...30	2 min	30 min		
87–104	31...40	1 min	20 min		

Rotary drilling

Hammer drilling

t_{work}

t_{cure}

Temperature of base material

Dry base material

Water saturated base material

Trigger pulls

Hollow concrete masonry unit (CMU)

Hollow brick

Grout-filled CMU

1a

TE-CD
TE-YD

t_{inst}

2

3

4

5

6

7

8

9

10

11

12

12

9

10

11

12

FIGURE 9—MANUFACTURERS PRINTED INSTALLATION INSTRUCTIONS

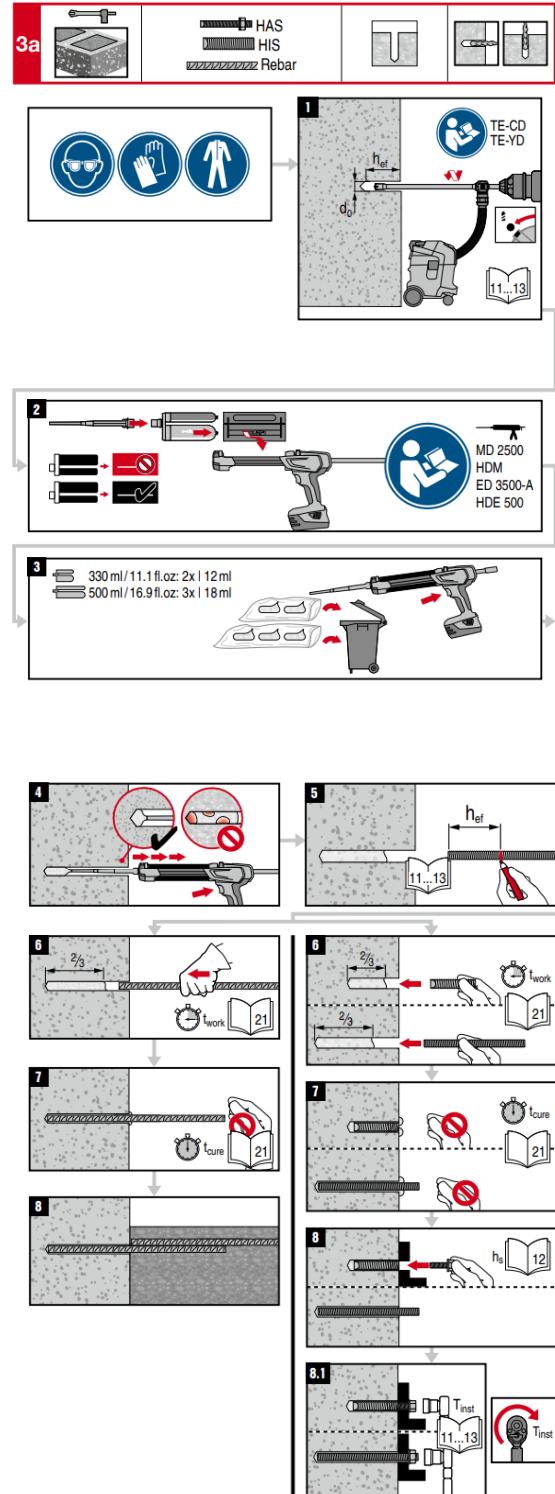
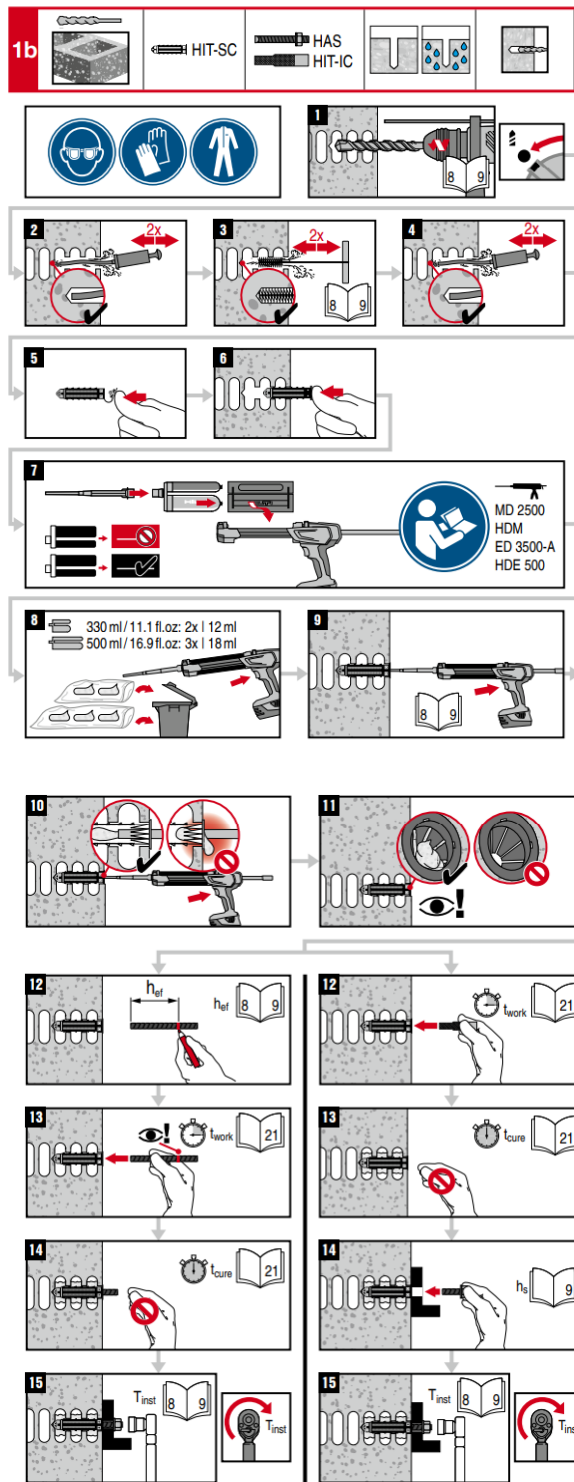
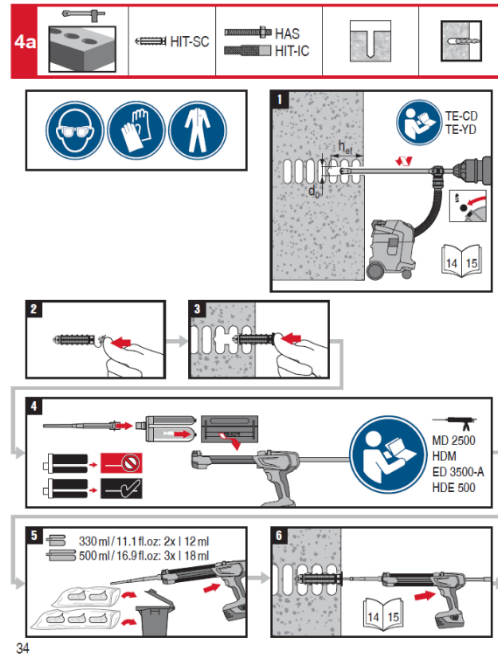
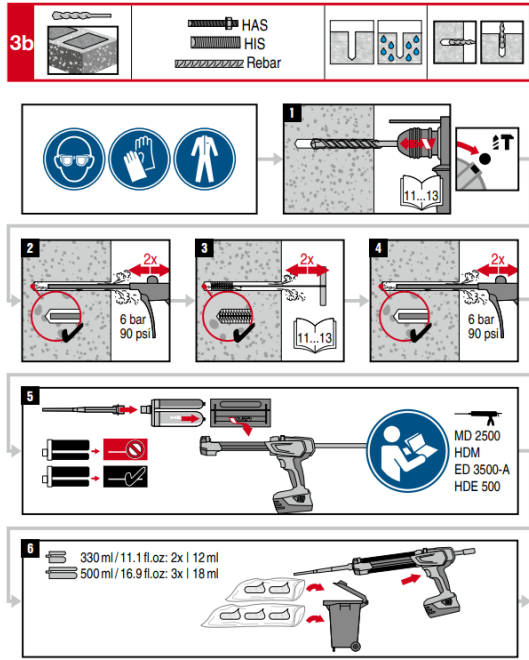
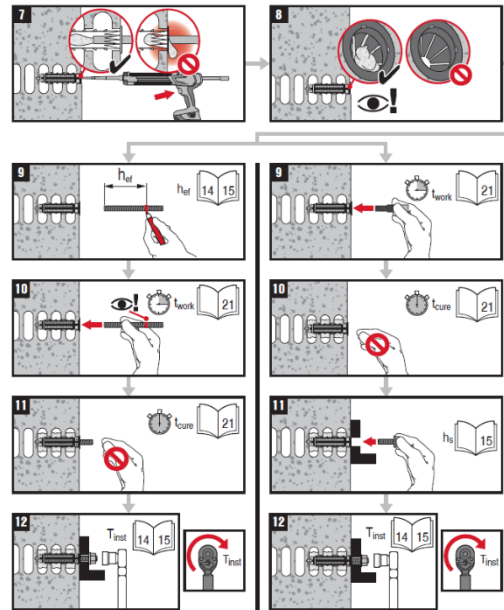
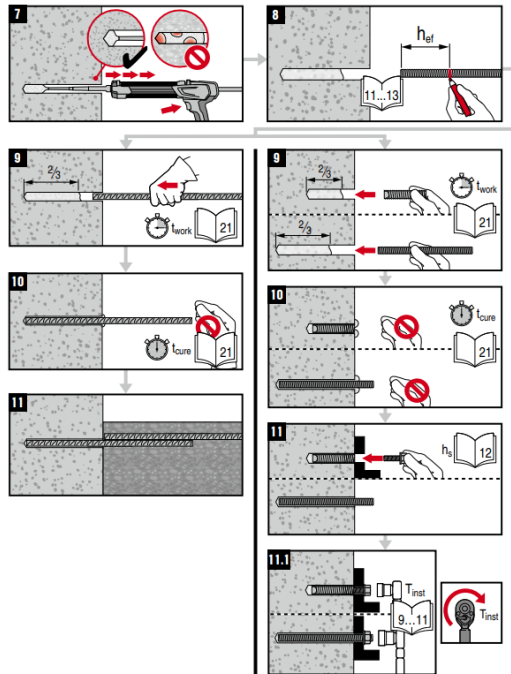

FIGURE 9—MANUFACTURERS PRINTED INSTALLATION INSTRUCTIONS (CONTINUED)



34



35

FIGURE 9—MANUFACTURERS PRINTED INSTALLATION INSTRUCTIONS (CONTINUED)

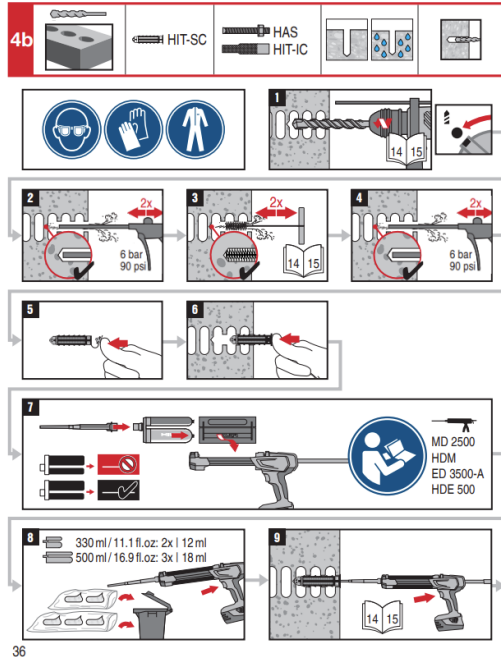

36

Adhesive anchoring system for rebar and anchor fastenings.

For use in hollow and solid masonry of clay brick, concrete block and multi wythe wall.

Hilti HIT-HY 270
Contains: methacrylates (A), dibenzoyl peroxide (B), boric acid (A), 4-tert-butylpyrocatechol (A)

Danger

H317	May cause an allergic skin reaction. (A,B)
H319	Causes serious eye irritation. (A)
H360	May damage fertility or the unborn child. (A)
H410	Very toxic to aquatic life with long lasting effects. (B)
H412	Harmful to aquatic life with long lasting effects. (A)

P262 Do not get in eyes, on skin, or on clothing.
 P280 Wear protective gloves/protective clothing/eye protection.
 P302+P352 IF ON SKIN: Wash with plenty of soap and water.
 P305+P351+P338 IF IN EYES: Rinse cautiously with water for several minutes. Remove contact lenses, if present and easy to do. Continue rinsing.
 P333+P313 If skin irritation or rash occurs: Get medical advice/attention.
 P337+P313 If eye irritation persists: Get medical advice/attention.

Disposal considerations

Empty packs:
 ▶ Leave the mixer attached and dispose of via the local Green Dot recovery system or EAK waste material code: 150102 plastic packaging

Full or partially emptied packs:
 ▶ Must be disposed of as special waste in accordance with official regulations.
 EAK waste material code: 08 04 09* waste adhesives and sealants containing organic solvents or other dangerous substances, or EAK waste material code: 20 01 27* paint, inks, adhesives and resins containing dangerous substances.

Warranty: Refer to standard Hilti terms and conditions of sale for warranty information.

Failure to observe these installation instructions, use of non-Hilti anchors, poor or questionable base material conditions, or unique applications may affect the reliability or performance of the fastenings.

Content: 11.1 fl.oz. / 330 ml 16.9 fl.oz. / 500 ml
Weight: 20.8 oz / 590 g 28.9 oz / 820 g

Product Information

- Always keep these instructions together with the product even when given to other persons.
- Check expiration date: See imprint on foil pack manifold (month/year). Do not use expired product.
- Foil pack temperature during usage: between 41 °F and 104 °F / +5 °C and 40 °C.
- Base material temperature at time of installation: between 23 °F and 104 °F / -5 °C and 40 °C.
- **Exception in hollow, solid and multi-wythe solid clay brick:** between 41 °F and 104 °F / +5 °C and 40 °C.
- Conditions for transport and storage: Keep in a cool, dry and dark place between 41 °F and 77 °F / 5 °C and 25 °C.
- For any application not covered by this document / beyond values specified, please contact Hilti.
- Partially used foil packs must remain in the cassette and has to be used within 4 weeks. Leave the mixer attached on the foil pack manifold and store within the cassette under the recommended storage conditions. If reused, attach a new mixer and discard the initial quantity of anchor adhesive.

WARNING

- ▲ **Improper handling may cause mortar splashes.**
 - Always wear eye protection, gloves and protective clothes during installation.
 - Never start dispensing without a mixer properly screwed on.
 - Attach a new mixer prior to dispensing a new foil pack (ensure snug fit).
 - Use only the type of mixer (HIT-RE-M) supplied with the adhesive. Do not modify the mixer in any way.
 - Never use damaged foil packs and/or damaged or unclean foil pack holders (cassettes).
- ▲ **Poor load values / potential failure of fastening points due to inadequate borehole cleaning.**
 - Hilti hollow drill bits TE-CD, TE-YD must be used in conjunction with a properly maintained Hilti vacuum cleaner with model and suction capacity (volumetric flow rate) as specified in the accessory table.
 - The boreholes must be free of debris, dust, water, ice, oil, grease and other contaminants prior to adhesive injection.
 - For blowing out the borehole - blow out with oil free air until return air stream is free of noticeable dust.
 - For brushing the borehole - only use specified wire brush. The brush must resist insertion into the borehole - if not the brush is too small and must be replaced.
- ▲ **Borehole filling in solid masonry:** Ensure that boreholes are filled from the back of the borehole without forming air voids. If necessary use the accessories / extensions to reach the back of the borehole.
- ▲ **Borehole filling in hollow masonry:** Use a mesh sleeve. Fill the mesh sleeve with mortar from the centering cap until mortar escapes at the centering cap (filling control).
- ▲ **Multi-Wythe Solid Brick application: HIT-SC sieve sleeves / sieve sleeve combinations have to be filled outside the bore hole:** Push the mixer to the bottom of the last mesh sleeve (use mixer extension if necessary), inject the anchor adhesive starting at the bottom of the last mesh sleeve while slowly withdrawing the mixing nozzle towards the centering cap, step by step, after each pull of the trigger. HIT-SC sieve sleeves have to be filled completely without forming air voids until anchor adhesive escapes at the centering cap (filling control).
- ▲ **Not adhering to these setting instructions can result in failure of fastening points!**

37

FIGURE 9—MANUFACTURERS PRINTED INSTALLATION INSTRUCTIONS (CONTINUED)

HAS

HAS	HIT-SC	d ₀ [inch]	d ₀ [inch]	h ₀ [inch]	h _{ef} [inch]	HIT-RB	d ₁ [inch]	T _{inst} [ft lb]
1/4"	12 x 50	1/2	1/2	2 3/8	2	1/2	9/32	≤ 2.2
5/16"	16 x 50	5/8	5/8	2 3/8	2	5/8	7/16	≤ 3
3/8"	16 x 50	n/a	1 1/16	2 3/8	2	1 1/16	9/16	≤ 4.5

	1/4"	5/16"	3/8"	1/2"	
HIT-SC	M6	M8	M10	M12	
MD 2500 / HDM	2	4	3	5	3
ED 3500-A / HDE 500	3	6	4	7	4

Hilti VC 150/300
min. 61 l/s

HIS

HIS	d ₀ [inch]	d ₀ [inch]	h ₀ = h _{ef} [inch]	HIT-RB	d ₁ [inch]	h ₀ [inch]	T _{inst} [ft lb]
3/8"	n/a	1 1/16	4 9/8	1 1/16	7/16	3/8 - 1	≤ 6
1/2"	7/8	7/8	5	7/8	9/16	1/2 - 1 1/4	≤ 7.5

HAS

HAS	HIT-SC	d ₀ [inch]	d ₀ [inch]	h ₀ [inch]	h _{ef} [inch]	HIT-RB	d ₁ [inch]	T _{inst} [ft lb]
1/4"	12 x 85	1/2	1/2	3 3/4	3 1/8	1/2	9/32	≤ 2.2
5/16"	16 x 85	5/8	5/8	3 3/4	3 1/8	5/8	7/16	≤ 3
3/8"	16 x 85	n/a	1 1/16	3 3/4	3 1/8	1 1/16	9/16	≤ 4.5

	1/4"	5/16"	3/8"	1/2"	
HIT-SC	M6	M8	M10	M12	
MD 2500 / HDM	2	4	3	5	3
ED 3500-A / HDE 500	3	6	4	7	4

Hilti VC 150/300
min. 61 l/s

HIT-IC

HIT-IC	HIT-SC	d ₀ [inch]	d ₀ [inch]	h ₀ [inch]	h _{ef} [inch]	HIT-RB	d ₁ [inch]	h ₀ [inch]	T _{inst} [ft lb]
5/16 x 2	16 x 50	5/8	5/8	2 3/8	2	5/8	3/8	3/8 - 1 1/2	≤ 2.2
3/8 x 2	16 x 50	7/8	7/8	2 3/8	2	7/8	7/16	3/8 - 1 1/2	≤ 3
1/2 x 2	16 x 50	n/a	1 1/16	2 3/8	2	1 1/16	9/16	1/2 - 1 1/2	≤ 4.5

	5/16 x 2	3/8 x 3 3/16	3/8 x 2	3/8 x 3 3/16	1/2 x 2	1/2 x 3 3/16	
HIT-SC	M8 x 50	M8 x 80	M10 x 50	M10 x 80	M12 x 50	M12 x 80	
MD 2500 / HDM	3	5	5	8	5	8	
ED 3500-A / HDE 500	4	7	7	10	7	10	

Hilti VC 150/300
min. 61 l/s

HIT-IC

HIT-IC	HIT-SC	d ₀ [inch]	d ₀ [inch]	h ₀ [inch]	h _{ef} [inch]	HIT-RB	d ₁ [inch]	h ₀ [inch]	T _{inst} [ft lb]
5/16 x 3 3/16	16 x 85	5/8	5/8	3 3/4	3 1/8	5/8	3/8	3/8 - 3	≤ 2.2
3/8 x 3 3/16	22 x 85	7/8	7/8	3 3/4	3 1/8	7/8	7/16	3/8 - 3	≤ 3
1/2 x 3 3/16	22 x 85	n/a	1 1/16	3 3/4	3 1/8	1 1/16	9/16	1/2 - 3	≤ 4.5

	5/16 x 2	3/8 x 3 3/16	3/8 x 2	3/8 x 3 3/16	1/2 x 2	1/2 x 3 3/16	
HIT-SC	M8 x 50	M8 x 80	M10 x 50	M10 x 80	M12 x 50	M12 x 80	
MD 2500 / HDM	3	5	5	8	5	8	
ED 3500-A / HDE 500	4	7	7	10	7	10	

Hilti VC 150/300
min. 61 l/s

HAS

HAS	d ₀ [inch]	d ₀ [inch]	h ₀ = h _{ef} [inch]	HIT-RB	d ₁ [inch]	T _{inst} [ft lb]
3/8"	n/a	7/16	2 3/8 - 7 1/2	7/16	7/16	≤ 6
1/2"	9/16	9/16	2 3/4 - 10	9/16	9/16	≤ 7.5
5/8"	3/4	3/4	3 1/8 - 10	3/4	1 1/16	≤ 7.5
3/4"	7/8	7/8	3 1/2 - 10	7/8	1 3/16	≤ 10

Rebar

Rebar	d ₀ [inch]	d ₀ [inch]	h ₀ = h _{ef} [inch]	HIT-RB
#3	1/2	1/2	2 3/8 - 7 1/2	1/2
#4	5/8	5/8	2 3/4 - 10	5/8
#5	3/4	3/4	3 1/8 - 10	3/4
#6	7/8	7/8	3 1/2 - 10	7/8

FIGURE 9—MANUFACTURERS PRINTED INSTALLATION INSTRUCTIONS (CONTINUED)

DIVISION: 04 00 00—MASONRY
Section: 04 05 19.16—Masonry Anchors

REPORT HOLDER:

HILTI, INC.

EVALUATION SUBJECT:

HILTI HIT-HY 270 ADHESIVE ANCHOR SYSTEM IN CRACKED AND UNCRACKED GROUTED AND UNGROUTED CONCRETE MASONRY UNIT WALLS AND CLAY BRICK MASONRY WALLS

1.0 REPORT PURPOSE AND SCOPE

Purpose:

The purpose of this evaluation report supplement is to indicate that the Hilti HIT-HY 270 Adhesive Anchor System, described in ICC-ES evaluation report [ESR-4143](#), has also been evaluated for compliance with the codes noted below as adopted by the Los Angeles Department of Building and Safety (LADBS).

Applicable code editions:

- 2023 *City of Los Angeles Building Code* ([LABC](#))
- 2023 *City of Los Angeles Residential Code* ([LARC](#))

2.0 CONCLUSIONS

The Hilti HIT-HY 270 Adhesive Anchor System, described in Sections 2.0 through 7.0 of the evaluation report [ESR-4143](#), complies with the LABC Chapter 21, and the LARC, and is subject to the conditions of use described in this supplement.

3.0 CONDITIONS OF USE

The Hilti HIT-HY 270 Adhesive Anchor System described in this evaluation report supplement must comply with all of the following conditions:

- All applicable sections in the evaluation report [ESR-4143](#).
- The design, installation, conditions of use and identification of the anchors are in accordance with the 2021 *International Building Code*® (2021 IBC) provisions noted in the evaluation report [ESR-4143](#).
- The design, installation and inspection are in accordance with additional requirements of LABC Chapters 16 and 17, as applicable.
- Under the LARC, an engineered design in accordance with LARC Section R301.1.3 must be submitted.
- The allowable load values listed in the evaluation report and tables are for the connection of the adhesive anchors to the masonry. The connection between the adhesive anchors and the connected members shall be checked for capacity (which may govern).
- For use in wall anchorage assemblies to flexible diaphragm applications, anchors shall be designed per the requirements of City of Los Angeles Information Bulletin P/BC 2020-071.

This supplement expires concurrently with the evaluation report, reissued January 2025 and revised April 2025.

DIVISION: 04 00 00—MASONRY
Section: 04 05 19.16—Masonry Anchors

REPORT HOLDER:

HILTI, INC.

EVALUATION SUBJECT:

HILTI HIT-HY 270 ADHESIVE ANCHOR SYSTEM IN CRACKED AND UNCRACKED GROUTED AND UNGROUTED CONCRETE MASONRY UNIT WALLS AND CLAY BRICK MASONRY WALLS

1.0 REPORT PURPOSE AND SCOPE**Purpose:**

The purpose of this evaluation report supplement is to indicate that the Hilti HIT-HY 270 Adhesive Anchor System, described in ICC-ES evaluation report ESR-4143, has also been evaluated for compliance with the codes noted below.

Applicable code editions:

- 2023 *Florida Building Code—Building*
- 2023 *Florida Building Code—Residential*

2.0 CONCLUSIONS

The Hilti HIT-HY 270 Adhesive Anchor System, described in Sections 2.0 through 7.0 of ICC-ES evaluation report ESR-4143, complies with the *Florida Building Code—Building* and the *Florida Building Code—Residential*, provided the design requirements are determined in accordance with the *Florida Building Code—Building* or the *Florida Building Code—Residential*, as applicable. The installation requirements noted in ICC-ES evaluation report ESR-4143 for the 2021 *International Building Code*® meet the requirements of the *Florida Building Code—Building* or the *Florida Building Code—Residential*, as applicable.

Use of the Hilti HIT-HY 270 Adhesive Anchor System has also been found to be in compliance with the High-Velocity Hurricane Zone provisions of the *Florida Building Code—Building* and the *Florida Building Code—Residential*, with the following conditions:

- a) Design and installation must meet the requirements of Section 2122.7 of the *Florida Building Code—Building*.
- b) For anchorage of wood members, the connections subject to uplift must be designed for no less than 700 pounds (3114 N).

For products falling under Florida Rule 61G20-3, verification that the report holder's quality assurance program is audited by a quality assurance entity approved by the Florida Building Commission for the type of inspections being conducted is the responsibility of an approved validation entity (or the code official, when the report holder does not possess an approval by the Commission).

This supplement expires concurrently with the evaluation report, reissued January 2025 and revised April 2025.