



HILTI TECHNICAL BULLETIN

Date; February 28, 2018

Subject: KWIK HUS-EZ 3/8 X 2-1/8 I 1/2

Hilti has introduced a new version of the KWIK HUS-EZ I anchor. The KWIK HUS-EZ 3/8"X2 1/2" I 1/2" anchor is a 3/8-in. diameter screw anchor with an internally threaded head for attachment of 1/2-in. diameter threaded rods. The tables below provide installation parameters and design load data in Normal Weight Concrete and Lightweight Concrete Over Metal Deck. The anchor is also approved by Factory Mutual for sprinkler pipe up to 8-in. in diameter. This product will be included in the next revision of ESR-3027.

The design tables in Tables 2 to 6 are Hilti Simplified Design Tables. The load values were developed using the design parameters and variables that are expected to be included in ESR-3027 and the equations of ACI 318-14 Chapter 17. For a detailed explanation of the Hilti Simplified Design Tables, refer to section 3.1.8 of Hilti Product Technical Guide Vol. 2 Ed. 17. Tables 7 to 11 are based on Canadian Limit State Design. Table 12 contains allowable loads for installations in Hollow Core Concrete Panels.



Figure 1 – KWIK HUS-EZ 3/8" X 2 1/2" I 1/2"

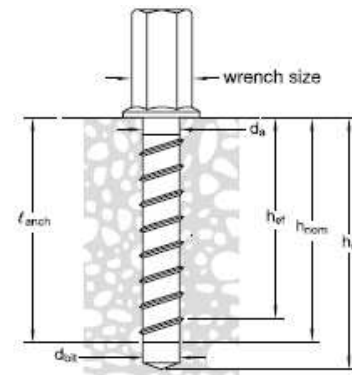

Figure 2 – KWIK HUS-EZ anchor installation details

Table 1 – KWIK HUS EZ I installation specifications

Setting information	Symbol	Units	Nominal anchor diameter
			3/8
Nominal bit diameter	d_{bit}	in.	3/8
Nominal embedment	h_{nom}	in.	2-1/8
Effective embedment	h_{ef}	in.	1.54
Minimum hole depth	h_o	in.	2-3/8
Minimum Base Material Thickness	h_{min}	in.	3-5/8
Installation torque	T_{inst}	ft.-lb.	40
Wrench size	-	in.	3/4
Hilti impact setting tools	-	-	SID 4-A22/18-A and SIW 22/18-A
Insert diameter	-	in.	1/2

Table 2 - Hilti KWIK HUS-EZ I design strength with concrete / pullout failure in uncracked concrete ^{1,2,3,4}

Nominal anchor diameter in.	Nominal embed. depth in. (mm)	Tension - ϕN_n				Shear - ϕV_n			
		$f'_c = 2500$ psi (17.2 MPa) lb (kN)	$f'_c = 3000$ psi (20.7 MPa) lb (kN)	$f'_c = 4000$ psi (27.6 MPa) lb (kN)	$f'_c = 6000$ psi (41.4 MPa) lb (kN)	$f'_c = 2500$ psi (17.2 MPa) lb (kN)	$f'_c = 3000$ psi (20.7 MPa) lb (kN)	$f'_c = 4000$ psi (27.6 MPa) lb (kN)	$f'_c = 6000$ psi (41.4 MPa) lb (kN)
3/8	2-1/8 (54)	1,490 (6.6)	1,630 (7.3)	1,885 (8.4)	2,305 (10.3)	1,605 (7.1)	1,755 (7.8)	2,030 (9.0)	2,485 (11.1)

Table 3 - Hilti KWIK HUS-EZ I design strength with concrete / pullout failure in cracked concrete ^{1,2,3,4,5}

Nominal anchor diameter in.	Nominal embed. depth in. (mm)	Tension - ϕN_n				Shear - ϕV_n			
		$f'_c = 2500$ psi (17.2 MPa) lb (kN)	$f'_c = 3000$ psi (20.7 MPa) lb (kN)	$f'_c = 4000$ psi (27.6 MPa) lb (kN)	$f'_c = 6000$ psi (41.4 MPa) lb (kN)	$f'_c = 2500$ psi (17.2 MPa) lb (kN)	$f'_c = 3000$ psi (20.7 MPa) lb (kN)	$f'_c = 4000$ psi (27.6 MPa) lb (kN)	$f'_c = 6000$ psi (41.4 MPa) lb (kN)
3/8	2-1/8 (54)	1,055 (4.7)	1,155 (5.1)	1,335 (5.9)	1,635 (7.3)	1,135 (5.0)	1,245 (5.5)	1,435 (6.4)	1,760 (7.8)

1 See Section 3.1.8.6 of Hilti Product Technical Guide Ed. 17 to convert design strength value to ASD value.

2 Linear interpolation between embedment depths and concrete compressive strengths is not permitted.

3 Tabulated values are for a single anchor with a minimum edge distance 2-3/4 inches and minimum spacing of 4-5/8 inches.

Compare table value to the steel value in Table 4. The lesser of the values is to be used for the design.

4 Tabular values are for normal weight concrete only. For lightweight concrete multiply design strength by λ_a as follows:

For sand-lightweight, $\lambda_a = 0.68$. For all-lightweight, $\lambda_a = 0.60$.

5 Tabular values are for static loads only. For seismic tension loads, multiply cracked concrete tabular values by $\alpha_{N,seis} = 0.75$:

No reduction needed for seismic shear. See Section 3.1.8.7 of Hilti Product Technical Guide Ed 17 for additional information on seismic applications.

Table 4 - Steel design strength for Hilti KWIK HUS-EZ I anchors ^{1,2,6}

Nominal anchor diameter in.	Nominal internal thread diameter in.	Tensile ³ ϕN_{sa} lb (kN)	Shear ⁴ ϕV_{sa} lb (kN)	Seismic Shear ⁵ ϕV_{sa} lb (kN)
3/8	1/2-13 UNC	5,990 (26.6)	1,130 (5.0)	1,130 (5.0)

1 See Section 3.1.8.6 of Hilti Product Technical Guide Ed. 17 to convert design strength value to ASD value.

2 Hilti KWIK HUS-EZ I anchors are to be considered brittle steel elements.

3 Tensile $\phi N_{sa} = \phi A_{se,N} f_{uta}$ as noted in ACI 318-14 Ch. 17.

4 Shear values determined by static shear tests with $\phi V_{sa} < \phi 0.60 A_{se,V} f_{uta}$ as noted in ACI 318-14 Ch. 17.

5 Seismic shear values determined by seismic shear tests with $\phi V_{sa} \leq \phi 0.60 A_{se,V} f_{uta}$ as noted in ACI 318-14 Ch. 17.

See Section 3.1.8.7 of Hilti Product Technical Guide Ed 17 for additional information on seismic applications.

6 Values are for threaded rod or insert with $F_u \geq 125$ ksi. For use with inserts with F_u less than 125 ksi multiply the shear values by the ratio of F_u of insert and 125 ksi.

Table 5 - Hilti KWIK HUS-EZ I in the soffit of uncracked lightweight concrete over metal deck ^{1,2,3,4,5,6}

Nominal anchor diameter in.	Nominal internal thread diameter in.	Nominal embed. depth in. (mm)	Installation in lower flute				Installation in upper flute			
			Tension - ϕN_n		Shear - ϕV_n		Tension - ϕN_n		Shear - ϕV_n	
			$f'_c = 3000$ psi (20.7 MPa) lb (kN)	$f'_c = 4000$ psi (27.6 MPa) lb (kN)	$f'_c = 3000$ psi (20.7 MPa) lb (kN)	$f'_c = 4000$ psi (27.6 MPa) lb (kN)	$f'_c = 3000$ psi (20.7 MPa) lb (kN)	$f'_c = 4000$ psi (27.6 MPa) lb (kN)	$f'_c = 3000$ psi (20.7 MPa) lb (kN)	$f'_c = 4000$ psi (27.6 MPa) lb (kN)
3/8	1/2-13 UNC	2-1/8 (54)	1,225 (5.4)	1,415 (6.3)	1,565 (7.0)	1,565 (7.0)	1,895 (8.4)	2,190 (9.7)	2,400 (10.7)	2,400 (10.7)

Table 6 - Hilti KWIK HUS-EZ I in the soffit of cracked lightweight concrete over metal deck ^{1,2,3,4,5,6}

Nominal anchor diameter in.	Nominal internal thread diameter in.	Nominal embed. depth in. (mm)	Installation in lower flute				Installation in upper flute			
			Tension - ϕN_n ⁷		Shear - ϕV_n ^{7,8}		Tension - ϕN_n ⁷		Shear - ϕV_n ^{7,8}	
			$f'_c = 3000$ psi (20.7 MPa) lb (kN)	$f'_c = 4000$ psi (27.6 MPa) lb (kN)	$f'_c = 3000$ psi (20.7 MPa) lb (kN)	$f'_c = 4000$ psi (27.6 MPa) lb (kN)	$f'_c = 3000$ psi (20.7 MPa) lb (kN)	$f'_c = 4000$ psi (27.6 MPa) lb (kN)	$f'_c = 3000$ psi (20.7 MPa) lb (kN)	$f'_c = 4000$ psi (27.6 MPa) lb (kN)
3/8	1/2-13 UNC	2-1/8 (54)	855 (3.8)	985 (4.4)	1,565 (7.0)	1,565 (7.0)	1,325 (5.9)	1,530 (6.8)	2400 (10.7)	2,400 (10.7)

- 1 See Section 3.1.8.6 of Hilti Product Technical Guide Ed. 17 to convert design strength value to ASD value.
- 2 Linear interpolation between embedment depths and concrete compressive strengths is not permitted.
- 3 Tabular value is for one anchor per flute. Minimum spacing along the length of the flute is 6-3/8 inches.
- 4 Tabular values are lightweight concrete and no additional reduction factor is needed.
- 5 No additional reduction factors for spacing or edge distance need to be applied.
- 6 Comparison of the tabular values to the steel strength is not necessary. Tabular values control.
- 7 Tabular values are for static loads only. For seismic conditions $\alpha_{N,seis} = 0.75$.
- 8 For seismic shear, an additional factor must be applied to the cracked concrete tabular values for seismic conditions: $\alpha_{V,seis} = 0.85$
See Section 3.1.8.6 of Hilti Product Technical Guide Ed. 17 for additional information on seismic applications.

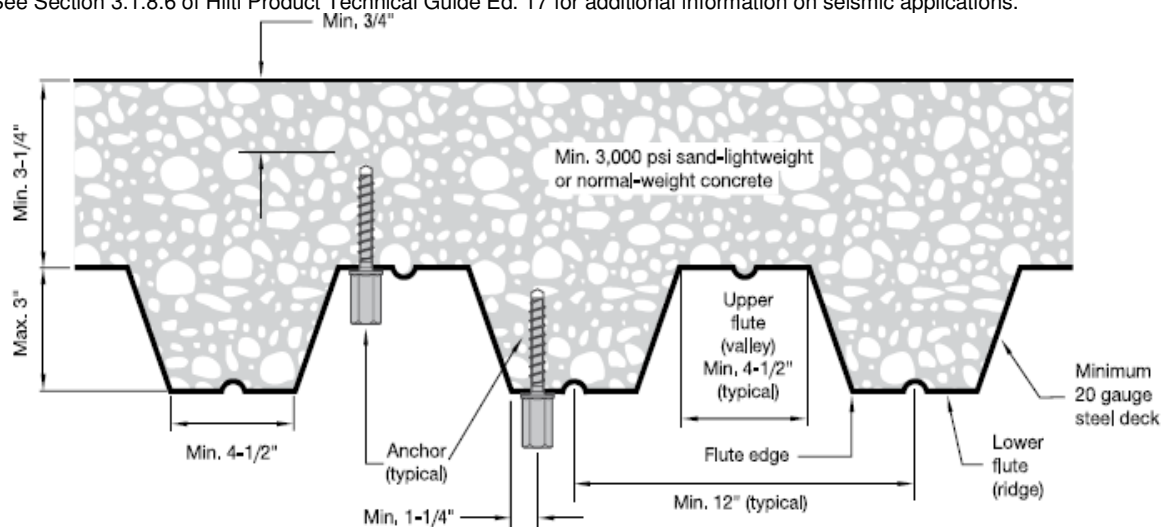

Figure 3 – Installations of KWIK HUS EZ I (KH-EZ I) in soffit of concrete over metal deck assemblies

Canadian Limit State Design

Limit State Design of anchors is described in the provisions of CSA A23.3-14 Annex D for post-installed anchors tested and assessed in accordance with ACI 355.2 for mechanical anchors and ACI 355.4 for adhesive anchors. Tables 7 to 11 of this section contains the Limit State Design tables with factored characteristic loads that are based on the loads that are expected to be published in ESR-3027. The factored resistance tables have characteristic design loads that are pre-factored by the applicable reduction factors for a single anchor with no anchor-to-anchor spacing or edge distance adjustments for the convenience of the user of this document. All the figures in the previous ACI 318-14 Chapter 17 design section are applicable to Limit State Design and the tables will reference these figures.

For a detailed explanation of the tables developed in accordance with CSA A23.3-14 Annex D, refer to Section 3.1.8 of the Hilti Product Technical Guide Ed. 17.

Table 7 - Hilti KWIK HUS-EZ I carbon steel screw anchor factored resistance with concrete / pullout failure in uncracked concrete ^{1,2,3,4,5}

Nominal anchor diameter in.	Nominal anchor diameter in.	Nominal embed. in. (mm)	Tension - N_r				Shear - V_r			
			$f'_c = 20$ MPa (2,900 psi) lb (kN)	$f'_c = 25$ MPa (3,625 psi) lb (kN)	$f'_c = 30$ MPa (4,350 psi) lb (kN)	$f'_c = 40$ MPa (5,800 psi) lb (kN)	$f'_c = 20$ MPa (2,900 psi) lb (kN)	$f'_c = 25$ MPa (3,625 psi) lb (kN)	$f'_c = 30$ MPa (4,350 psi) lb (kN)	$f'_c = 40$ MPa (5,800 psi) lb (kN)
3/8	3/8 (9.5)	2-1/8 (54)	1,595 (7.1)	1,785 (7.9)	1,955 (8.7)	2,260 (10.0)	1,595 (7.1)	1,785 (7.9)	1,955 (8.7)	2,260 (10.0)

Table 8 - Hilti KWIK HUS-EZ I carbon steel screw anchor factored resistance with concrete / pullout failure in cracked concrete ^{1,2,3,4,5}

Nominal anchor diameter in.	Nominal anchor diameter in.	Nominal embed. in. (mm)	Tension - N_r				Shear - V_r			
			$f'_c = 20$ MPa (2,900 psi) lb (kN)	$f'_c = 25$ MPa (3,625 psi) lb (kN)	$f'_c = 30$ MPa (4,350 psi) lb (kN)	$f'_c = 40$ MPa (5,800 psi) lb (kN)	$f'_c = 20$ MPa (2,900 psi) lb (kN)	$f'_c = 25$ MPa (3,625 psi) lb (kN)	$f'_c = 30$ MPa (4,350 psi) lb (kN)	$f'_c = 40$ MPa (5,800 psi) lb (kN)
3/8	3/8 (9.5)	2-1/8 (54)	1,120 (5.0)	1,250 (5.6)	1,370 (6.1)	1,580 (7.0)	1,120 (5.0)	1,250 (5.6)	1,370 (6.1)	1,580 (7.0)

1 See Section 3.1.8.6 of Hilti Product Technical Guide Ed 17 to convert design strength value to ASD value.

2 Linear interpolation between embedment depths and concrete compressive strengths is not permitted.

3 Tabulated values are for a single anchor with a minimum edge distance of 70mm (2-3/4 inches) and minimum spacing of 117mm (4-5/8 inches).

Compare table value to the steel value in Table 9. The lesser of the values is to be used for the design.

4 Tabular values are for normal weight concrete only. For lightweight concrete multiply design strength by λ_a as follows:

For sand-lightweight, $\lambda_a = 0.68$. For all-lightweight, $\lambda_a = 0.60$.

5 Tabular values are for static loads only. For seismic tension loads, multiply cracked concrete tabular values by $\alpha_{N,seis} = 0.75$:

No reduction needed for seismic shear. See Section 3.1.8.7 of Hilti Product Technical Guide Ed 17 for additional information on seismic applications.

Table 9 - Steel resistance for Hilti KWIK HUS-EZ I carbon steel screw anchor^{1,2,6}

Nominal anchor diameter in.	Internal thread diameter (UNC)	Tensile ³	Shear ⁴	Seismic Shear ⁵
		N _{sar} lb (kN)	V _{sar} lb (kN)	V _{sar,eq} lb (kN)
3/8	1/2-13 UNC	5,515 (24.5)	1,040 (4.6)	1,040 (4.6)

1 See Section 3.1.8.6 of Hilti Product Technical Guide Ed 17 to convert factored resistance value to ASD value.

2 Hilti KWIK HUS-EZ I carbon steel screw anchors are to be considered brittle steel elements.

3 Tensile $N_{sar} = A_{se,N} \phi_s f_{uta} R$ as noted in CSA A23.3-14 Annex D.

4 Shear determined by static shear tests with $V_{sar} < 0.6 A_{se,V} \phi_s f_{uta} R$ as noted in CSA A23.3-14 Annex D.

5 Seismic shear values determined by seismic shear tests with $V_{sar,eq} \leq 0.60 A_{se,V} \phi_s f_{uta} R$ as noted in CSA A23.3-14 Annex D.

See Section 3.1.8.7 of Hilti Product Technical Guide Ed17 for additional information on seismic applications.

6 Values are for threaded rod or insert with $F_u \geq 125$ ksi. For use with inserts with F_u less than 125 ksi multiply the shear values by the ratio of F_u of insert and 125 ksi.

Table 10 - Hilti KWIK HUS-EZ I in the soffit of uncracked lightweight concrete over metal deck^{1,2,3,4,5,6}

Nominal anchor diameter in.	Nominal internal thread diameter in.	Nominal embed. depth in. (mm)	Installation in lower flute				Installation in upper flute			
			Tension - N _r		Shear - V _r		Tension - N _r		Shear - V _r	
			f' _c = 20 MPa (2,900 psi) lb (kN)	f' _c = 30 MPa (4,350 psi) lb (kN)	f' _c = 20 MPa (2,900 psi) lb (kN)	f' _c = 30 MPa (4,350 psi) lb (kN)	f' _c = 20 MPa (2,900 psi) lb (kN)	f' _c = 30 MPa (4,350 psi) lb (kN)	f' _c = 20 MPa (2,900 psi) lb (kN)	f' _c = 30 MPa (4,350 psi) lb (kN)
			3/8	1/2-13 UNC	2-1/8 (54)	1,205 (5.4)	1,475 (6.6)	1,440 (6.4)	1,440 (6.4)	1,865 (8.3)

Table 11 - Hilti KWIK HUS-EZ I in the soffit of cracked lightweight concrete over metal deck^{1,2,3,4,5,6}

Nominal anchor diameter in.	Nominal internal thread diameter in.	Nominal embed. depth in. (mm)	Installation in lower flute				Installation in upper flute			
			Tension - N _r		Shear - V _r		Tension - N _r		Shear - V _r	
			f' _c = 20 MPa (2,900 psi) lb (kN)	f' _c = 30 MPa (4,350 psi) lb (kN)	f' _c = 20 MPa (2,900 psi) lb (kN)	f' _c = 30 MPa (4,350 psi) lb (kN)	f' _c = 20 MPa (2,900 psi) lb (kN)	f' _c = 30 MPa (4,350 psi) lb (kN)	f' _c = 20 MPa (2,900 psi) lb (kN)	f' _c = 30 MPa (4,350 psi) lb (kN)
			3/8	1/2-13 UNC	2-1/8 (54)	845 (3.8)	1,030 (4.6)	1,440 (6.4)	1,440 (6.4)	1,305 (5.8)

1 See Section 3.1.9.4 of Hilti Product Technical Guide Ed 17 to convert design strength value to ASD value.

2 Linear interpolation between embedment depths and concrete compressive strengths is not permitted.

3 Tabular value is for one anchor per flute across the flute. Minimum spacing along the length of the flute is the greater of 1.5 X flute width or 4 5/8 inches.

4 Tabular value is for lightweight concrete and no additional reduction factor is needed.

5 No additional reduction factors for spacing or edge distance need to be applied.

6 Comparison of the tabular values to the steel strength is not necessary. Tabular values control.

7 Tabular values are for static loads only. For seismic conditions $\alpha_{N,seis} = 0.75$

8 For seismic shear, an additional factor must be applied to the cracked concrete tabular values for seismic conditions: $\alpha_{V,seis} = 0.85$

See Section 3.1.8.6 of Hilti Product Technical Guide Ed. 17 for additional information on seismic applications.

Table 12 - Hilti KWIK HUS-EZ I allowable stress tension design values for installation into hollow core concrete panels^{1,2}

Hanger rod size	Minimum effective embedment h_{ef} in.	Allowable Tension Load ³ lb.	Ultimate Tension Load lb.
1/2-13 UNC	1-1/8	435	1750

Figure 4 – Installation of KWIK HUS-EZ I (KH-EZ I) in hollow core concrete panels

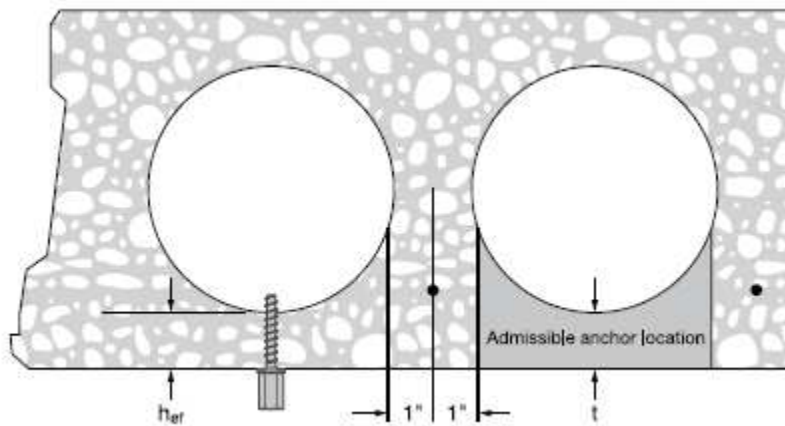

- 1 The admissible anchor location must be established to prevent damage to the prestressed cable during the drilling process. Verify the location and height of the cable with the hollow core plank supplier to confirm admissible anchor location.
- 2 Minimum compressive strength of prestressed concrete is 7,000 psi. Published ultimate loads represent the average results conducted in local base materials. Due to variations in materials and dimensional configurations, on-site testing is required to determine the actual performance.
- 3 Allowable loads calculated with a factor of safety of 4

Please feel free to contact our Engineering Technical Services department for more information or any questions.

Hilti Engineering Technical Services – United States
 (877) 749-6337 toll free
hnatechnicalservices@hilti.com

Hilti Engineering Technical Services – Canada
 (800) 363-4458 toll free
CATechnicalServices@hilti.com