

ICC-ES Evaluation Report

ESR-4266

Reissued December 2025

Revised June 2026

This report remains under an active continuous [compliance program through the end of December 2027](#)

This report also contains:

- [City of LA Supplement](#)
- [FL Supplement w/HVHZ](#)

For references to other reports.

See [ELC-4266](#) for [National Building Code of Canada® \(NBCC\)](#)

ICC-ES Evaluation Reports are not to be construed as representing aesthetics or any other attributes not specifically addressed, nor are they to be construed as an endorsement of the subject of the report or a recommendation for its use. There is no warranty by ICC Evaluation Service, LLC, express or implied, as to any finding or other matter in this report, or as to any product covered by the report.

Copyright © 2026 ICC Evaluation Service, LLC. All rights reserved.

<p>DIVISION: 03 00 00— CONCRETE</p> <p>Section: 03 16 00— Concrete Anchors</p> <p>DIVISION: 05 00 00— METALS</p> <p>Section: 05 05 19— Post-Installed Concrete Anchors</p>	<p>REPORT HOLDER: HILTI, INC.</p>	<p>EVALUATION SUBJECT: HILTI KWIK BOLT TZ2 CARBON AND STAINLESS STEEL ANCHORS IN CRACKED AND UNCRACKED CONCRETE</p>	
----------------------------------------------------------------------------------------------------------------------------------------------------------------------------------------------------------------------------	-----------------------------------------------------	-----------------------------------------------------------------------------------------------------------------------------------------------------------	-------------------------------------------------------------------------------------

1.0 EVALUATION SCOPE

Compliance with the following codes:

- 2024, 2021, 2018 and 2015 [International Building Code® \(IBC\)](#)
- 2024, 2021, 2018 and 2015 [International Residential Code® \(IRC\)](#)

Main references of this report are for the 2024 IBC and IRC. See [Table 10](#) and [Table 11](#) for applicable sections of the code for previous IBC and IRC editions.

Property evaluated:

Structural

2.0 USES

The Hilti Kwik Bolt TZ2 anchor (KB-TZ2) is used as anchorage to resist static, wind, and seismic (Seismic Design Categories A through F) tension and shear loads in cracked and uncracked normal-weight concrete and lightweight concrete having a specified compressive strength, f_c , of 2,500 psi to 8,500 psi (17.2 MPa to 58.6 MPa).

The 1/4-inch-, 3/8-inch- and 1/2-inch diameter (6.4 mm, 9.5 mm and 12.7 mm) carbon steel KB-TZ2 anchors may be installed in the topside of cracked and uncracked normal-weight or sand-lightweight concrete over metal deck having a minimum member thickness, $h_{min,deck}$, as noted in [Table 9](#) of this evaluation report and a specified compressive strength, f_c , of 3,000 psi to 8,500 psi (20.7 MPa to 58.6 MPa)

The 1/4-inch-, 3/8-inch-, 1/2-inch-, 5/8-inch- and 3/4-inch diameter (6.4 mm, 9.5 mm, 12.7 mm, 15.9 mm and 19.1 mm) carbon steel KB-TZ2 anchors may be installed in the soffit of cracked and uncracked normal-weight or sand-lightweight concrete over metal deck having a minimum specified compressive strength, f_c , of 3,000 psi (20.7 MPa).

The anchoring system complies with anchors as described in Section 1901.3 of the IBC. The anchors may also be used where an engineered design is submitted in accordance with Section R301.1.3 of the IRC.

3.0 DESCRIPTION

3.1 KB-TZ2:

KB-TZ2 anchors are torque-controlled, mechanical expansion anchors. KB-TZ2 anchors consist of a stud (anchor body), wedge (expansion elements), nut, and washer. The anchor (carbon steel version) is illustrated

in [Figure 1](#). The stud is manufactured from carbon steel or AISI Type 304 or Type 316 stainless steel materials. Carbon steel KB-TZ2 anchors have a minimum 5 μm (0.0002 inch) zinc-nickel plating. The expansion elements for the carbon steel KB-TZ2 anchors are fabricated from carbon steel or stainless steel. The expansion elements for the stainless steel KB-TZ2 anchors are fabricated from stainless steel. The hex nut for carbon steel conforms to ASTM A563-04, Grade A, and the hex nut for stainless steel conforms to ASTM F594.

The anchor body is comprised of a high-strength rod threaded at one end and a tapered mandrel at the other end. The tapered mandrel is enclosed by a three-section expansion element. The expansion element movement is restrained by the mandrel taper and by a collar. The anchor is installed in a predrilled hole with a hammer. When torque is applied to the nut of the installed anchor, the mandrel is drawn into the expansion element, which is in turn expanded against the wall of the drilled hole.

3.2 Concrete:

Normal-weight and lightweight concrete must conform to Sections 1903 and 1905 of the IBC.

3.3 Steel Deck Panels:

W and B steel deck panels must be in accordance with the configuration in [Figure 5A](#), [Figure 5B](#), [Figure 5C](#) and [Figure 5F](#) and have a minimum base steel thickness of 0.035 inch (0.899 mm, 20 gauge). Steel must comply with ASTM A653/A653M SS Grade 33 and have a minimum yield strength of 33,000 psi (228 MPa).

The 2-inch and 3.5-inch Dovetail steel deck panels must be in accordance with the configuration in [Figure 5D](#) and [Figure 5E](#) respectively, and must be fabricated from 20 ga. minimum steel thickness. Steel must comply with ASTM A1008 CS Type B and have a minimum yield strength of 28,000 psi (193 MPa) for the 2" deck and 32,400 psi (223 MPa) for the 3.5" deck.

4.0 DESIGN AND INSTALLATION

4.1 Strength Design:

4.1.1 General: Design strength of anchors complying with the 2024 IBC, as well as Section R301.1.3 of the 2024 IRC must be determined in accordance with ACI 318-19 Chapter 17 and this report.

Design parameters provided in [Table 4](#), [Table 5](#), [Table 6](#) and [Table 7](#) of this report are based on the 2024 IBC (ACI 318-19) unless noted otherwise in Sections 4.1.1 through 4.1.12. The strength design of anchors must comply with ACI 318-19 17.5.1.2, except as required in ACI 318-19 17.10.

Strength reduction factors, ϕ , as given in ACI 318-19 17.5.3 and noted in [Table 4](#), [Table 5](#), [Table 6](#) and [Table 7](#) of this report, must be used for load combinations calculated in accordance with Section 1605.1 of the 2024 IBC and Section 5.3 of ACI 318-19. The value of f'_c used in the calculations must be limited to a maximum of 8,000 psi (55.2 MPa), in accordance with ACI 318-19 17.3.1.

4.1.2 Requirements for Static Steel Strength in Tension: The nominal static steel strength, N_{sa} , of a single anchor in tension must be calculated in accordance with ACI 318-19 17.6.1.2. The resulting N_{sa} values are provided in [Table 4](#) and [Table 5](#) of this report. Strength reduction factors ϕ corresponding to ductile steel elements may be used.

4.1.3 Requirements for Static Concrete Breakout Strength in Tension: The nominal concrete breakout strength of a single anchor or group of anchors in tension, N_{cb} or N_{cbg} , respectively, must be calculated in accordance with ACI 318-19 17.6.2 with modifications as described in this section. The basic concrete breakout strength in tension, N_b , must be calculated in accordance with ACI 318-19 17.6.2.2 using the values of h_{ef} and k_{cr} as given in [Table 4](#) and [Table 5](#). The nominal concrete breakout strength in tension in regions where analysis indicates no cracking in accordance with ACI 318-19 17.6.2.5.1 must be calculated with k_{uncr} as given in [Table 4](#) and [Table 5](#) and with $\psi_{c,N} = 1.0$.

For carbon steel KB-TZ2 anchors installed in the soffit of sand-lightweight or normal-weight concrete on steel deck floor and roof assemblies, as shown in [Figure 5A](#), [Figure 5B](#), [Figure 5C](#), [Figure 5D](#) and [Figure 5E](#), calculation of the concrete breakout strength is not required.

4.1.4 Requirements for Static Pullout Strength in Tension: The nominal pullout strength of a single anchor in accordance with ACI 318-19 17.6.3.1 and 17.6.3.2.1 in cracked and uncracked concrete, $N_{p,cr}$ and $N_{p,uncr}$, respectively, are given in [Table 4](#) and [Table 5](#). For all design cases $\psi_{c,P} = 1.0$. In accordance with ACI 318-19 17.6.3 the nominal pullout strength in cracked concrete may be calculated in accordance with the following equation:

$$N_{p,f'_c} = N_{p,cr} \left(\frac{f'_c}{2,500} \right)^{n_{cr}} \quad (\text{lb, psi}) \quad (\text{Eq-1})$$

$$N_{p,f'_c} = N_{p,cr} \left(\frac{f'_c}{17.2} \right)^{n_{cr}} \quad (\text{N, MPa})$$

In regions where analysis indicates no cracking in accordance with ACI 318-19 17.6.3.3 the nominal pullout strength in tension may be calculated in accordance with the following equation:

$$N_{p,f'_c} = N_{p,uncr} \left(\frac{f'_c}{2,500} \right)^{n_{uncr}} \quad (\text{lb, psi}) \quad (\text{Eq-2})$$

$$N_{p,f'_c} = N_{p,uncr} \left(\frac{f'_c}{17.2} \right)^{n_{uncr}} \quad (\text{N, MPa})$$

Where values for $N_{p,cr}$ or $N_{p,uncr}$ are not provided in [Table 4](#) or [Table 5](#), the pullout strength in tension need not be evaluated.

The nominal pullout strength in cracked concrete of the carbon steel KB-TZ2 installed in the soffit of sand-lightweight or normal-weight concrete on steel deck floor and roof assemblies, as shown in [Figure 5A](#), [Figure 5B](#), [Figure 5C](#), [Figure 5D](#) and [Figure 5E](#) is given in [Table 8](#). In accordance with ACI 318-19 17.6.3.2.1 the nominal pullout strength in cracked concrete must be calculated in accordance with Eq-1, whereby the value of $N_{p,deck,cr}$ must be substituted for $N_{p,cr}$ and the value of 3,000 psi (20.7 MPa) must be substituted for the value of 2,500 psi (17.2 MPa) in the denominator. In regions where analysis indicates no cracking in accordance with ACI 318-19 17.6.3.3 the nominal strength in uncracked concrete must be calculated according to Eq-2, whereby the value of $N_{p,deck,uncr}$ must be substituted for $N_{p,uncr}$ and the value of 3,000 psi (20.7 MPa) must be substituted for the value of 2,500 psi (17.2 MPa) in the denominator. The use of stainless steel KB-TZ2 anchors installed in the soffit of concrete on steel deck assemblies is beyond the scope of this report.

4.1.5 Requirements for Static Steel Strength in Shear: The nominal steel strength in shear, V_{sa} , of a single anchor in accordance with ACI 318-19 17.7.1.2 is given in [Table 6](#) and [Table 7](#) of this report and must be used in lieu of the values derived by calculation from ACI 318-19 Eq. 17.7.1.2b. The shear strength $V_{sa,deck}$ of the carbon-steel KB-TZ2 as governed by steel failure of the KB-TZ2 installed in the soffit of sand-lightweight or normal-weight concrete on steel deck floor and roof assemblies, as shown in [Figure 5A](#), [Figure 5B](#), [Figure 5C](#), [Figure 5D](#) and [Figure 5E](#) is given in [Table 8](#).

4.1.6 Requirements for Static Concrete Breakout Strength in Shear: The nominal concrete breakout strength of a single anchor or group of anchors in shear, V_{cb} or V_{cbg} , respectively, must be calculated in accordance with ACI 318-19 17.7.2 with modifications as described in this section. The basic concrete breakout strength, V_b , must be calculated in accordance with ACI 318-19 17.7.2.2.1 based on the values provided in [Table 6](#) and [Table 7](#). The value of l_e used in ACI 318-19 Eq. 17.7.2.2.1a must be taken as no greater than the lesser of h_{ef} or $8d_a$. Anchors installed in light-weight concrete must use the reduction factors provided in ACI 318-19 17.2.4.

For carbon steel KB-TZ2 anchors installed in the soffit of sand-lightweight or normal-weight concrete on steel deck floor and roof assemblies, as shown in [Figure 5A](#), [Figure 5B](#), [Figure 5C](#), [Figure 5D](#) and [Figure 5E](#) calculation of the concrete breakout strength in shear is not required.

4.1.7 Requirements for Static Concrete Pryout Strength in Shear: The nominal concrete pryout strength of a single anchor or group of anchors, V_{cp} or V_{cpg} , respectively, must be calculated in accordance with ACI 318-19 17.7.3 modified by using the value of k_{cp} provided in [Table 6](#) and [Table 7](#) of this report and the value of N_{cb} or N_{cbg} as calculated in Section 4.1.3 of this report.

For carbon steel KB-TZ2 anchors installed in the soffit of sand-lightweight or normal-weight concrete over profile steel deck floor and roof assemblies, as shown in [Figure 5A](#), [Figure 5B](#), [Figure 5C](#), [Figure 5D](#) and [Figure 5E](#) calculation of the concrete pry-out strength in accordance with ACI 318-19 17.7.3 is not required.

4.1.8 Requirements for Seismic Design:

4.1.8.1 General: For load combinations including seismic, the design must be performed in accordance with ACI 318-19 17.10. Modifications to ACI 318-19 17.10 shall be applied under Section 1905.7 of the 2024 IBC.

The anchors comply with ACI 318-19 2.3, as ductile steel elements and must be designed in accordance with ACI 318-19 17.10.5, 17.10.6, 17.10.7 or 17.10.4. Strength reduction factors, ϕ , are given in [Table 4](#), [Table 5](#), [Table 6](#) and [Table 7](#) of this report. The anchors may be installed in structures assigned to Seismic Design Categories A through F of the IBC.

4.1.8.2 Seismic Tension: The nominal steel strength and nominal concrete breakout strength for anchors in tension must be calculated in accordance with ACI 318-19 17.6.1 and 17.6.2 as described in Sections 4.1.2 and 4.1.3 of this report. In accordance with ACI 318-19 17.6.3.2.1 the appropriate pullout strength in tension for seismic loads, $N_{p,eq}$, described in [Table 4](#) and [Table 5](#) or $N_{p,deck,cr}$ described in [Table 8](#) must be used in lieu of N_p , as applicable. The value of $N_{p,eq}$ or $N_{p,deck,cr}$ may be adjusted by calculation for concrete strength in accordance with Eq-1 and Section 4.1.4 whereby the value of $N_{p,deck,cr}$ must be substituted for $N_{p,cr}$ and the value of 3,000 psi (20.7 MPa) must be substituted for the value of 2,500 psi (17.2 MPa) in the denominator. If no values for $N_{p,eq}$ or $N_{p,deck,eq}$ are given in [Table 4](#), [Table 5](#), or [Table 8](#), the static design strength values govern.

4.1.8.3 Seismic Shear: The nominal concrete breakout strength and pryout strength in shear must be calculated in accordance with ACI 318-19 17.7.2 and 17.7.3 as described in Sections 4.1.6 and 4.1.7 of this report. In accordance with ACI 318-19 17.7.1.2, the appropriate value for nominal steel strength for seismic loads, $V_{sa,eq}$ described in [Table 6](#) and [Table 7](#) or $V_{sa,deck,eq}$ described in [Table 8](#) must be used in lieu of V_{sa} , as applicable.

4.1.9 Requirements for Interaction of Tensile and Shear Forces: For anchors or groups of anchors that are subject to the effects of combined tension and shear forces, the design must be performed in accordance with ACI 318-19 17.8.

4.1.10 Requirements for Minimum Member Thickness, Minimum Anchor Spacing and Minimum Edge Distance: In lieu of ACI 318-19 17.9.2 values of s_{min} and c_{min} as given in [Table 3](#) of this report must be used. In lieu of ACI 318-19 17.9.4, minimum member thicknesses h_{min} as given in [Tables 3](#) and [4](#) of this report must be used. Additional combinations for minimum edge distance, c_{min} , and spacing, s_{min} , may be derived by linear interpolation between the given boundary values as described in [Figure 4](#).

For carbon steel KB-TZ2 anchors installed in the topside of sand-lightweight or normal-weight concrete over profile steel deck floor and roof assemblies, the anchors must be installed in accordance with [Table 9](#) and [Figure 5F](#).

For carbon steel KB-TZ2 anchors installed in the soffit of sand-lightweight or normal-weight concrete over profile steel deck floor and roof assemblies, the anchors must be installed in accordance with [Figure 5A](#), [Figure 5B](#), [Figure 5C](#), [Figure 5D](#) and [Figure 5E](#) and shall have an axial spacing along the flute equal to the greater of $3h_{ef}$ or 1.5 times the flute width.

4.1.11 Requirements for Critical Edge Distance: In applications where $c < c_{ac}$ and supplemental reinforcement to control splitting of the concrete is not present, the concrete breakout strength in tension for uncracked concrete, calculated in accordance with ACI 318-19 17.6.2 must be further multiplied by the factor $\Psi_{cp,N}$ as given by Eq-3:

$$\Psi_{cp,N} = \frac{c}{c_{ac}} \quad (\text{Eq-3})$$

whereby the factor $\Psi_{cp,N}$ need not be taken as less than $\frac{1.5h_{ef}}{c_{ac}}$. For all other cases, $\Psi_{cp,N} = 1.0$. In lieu of using ACI 318-19 17.9.5 values of c_{ac} must comply with [Table 4](#) or [Table 5](#).

4.1.12 Lightweight Concrete: For the use of anchors in lightweight concrete, the modification factor λ_a equal to 0.8 λ is applied to all values of $\sqrt{f'_c}$ affecting N_n and V_n .

For ACI 318-19 (2024 IBC), λ shall be determined in accordance with ACI 318-19.

For anchors installed in the soffit of sand-lightweight concrete-filled steel deck and floor and roof assemblies, further reduction of the pullout values provided in this report is not required.

4.2 Allowable Stress Design (ASD):

4.2.1 General: Design values for use with allowable stress design (working stress design) load combinations calculated in accordance with Section 1605.1 of the 2024 IBC must be established as follows:

$$T_{allowable,ASD} = \frac{\phi N_n}{\alpha}$$

$$V_{allowable,ASD} = \frac{\phi V_n}{\alpha}$$

where:

$T_{allowable,ASD}$ = Allowable tension load (lbf or kN).

$V_{allowable,ASD}$ = Allowable shear load (lbf or kN).

ϕN_n = Lowest design strength of an anchor or anchor group in tension as determined in accordance with ACI 318-19 Chapter 17 and 2024 IBC Section 1905.7, and Section 4.1 of this report, as applicable (lbf or N).

ϕV_n = Lowest design strength of an anchor or anchor group in shear as determined in accordance with ACI 318-19 Chapter 17 and 2024 IBC Section 1905.7, and Section 4.1 of this report, as applicable (lbf or N).

α = Conversion factor calculated as a weighted average of the load factors for the controlling load combination. In addition, α must include all applicable factors to account for nonductile failure modes and required over-strength.

The requirements for member thickness, edge distance and spacing, described in this report, must apply.

4.2.2 Interaction of Tensile and Shear Forces: The interaction must be calculated and consistent with ACI 318-19 17.8 as follows:

For shear loads $V_{applied} \leq 0.2V_{allowable,ASD}$, the full allowable load in tension is permitted.

For tension loads $T_{applied} \leq 0.2T_{allowable,ASD}$, the full allowable load in shear is permitted.

For all other cases:

$$\frac{T_{applied}}{T_{allowable,ASD}} + \frac{V_{applied}}{V_{allowable,ASD}} \leq 1.2 \quad (\text{Eq-4})$$

4.2.3 Installation:

Installation parameters are provided in [Table 1](#) and [Figure 2](#), [Figure 5A](#), [Figure 5B](#), [Figure 5C](#), [Figure 5D](#), [Figure 5E](#) and [Figure 5F](#). Anchor locations must comply with this report and plans and specifications approved by the code official. The Hilti KB-TZ2 must be installed in accordance with manufacturer's published instructions and this report. In case of conflict, this report governs. Anchors must be installed in holes drilled into the concrete using carbide-tipped masonry drill bits complying with ANSI B212.15-1994, using the Hilti SafeSet System™ with Hilti TE-YD or TE-CD Hollow Drill Bits complying with ANSI B212.15-1994 with a Hilti vacuum in accordance with [Figure 6](#) and [Figure 7](#), or using Hilti SPX-T core bits in accordance with [Figure 7](#). The Hollow Drill Bits are not permitted for use with the 1/4-inch and 3/8-inch diameter KB-TZ2 anchors. The Hilti SPX-T core bits are not permitted for use with the 1/4-inch and 1-inch diameter KB-TZ2 anchors. The minimum drilled hole depth, h_o , is given in [Table 1](#). If dust and debris is removed from the drilled hole with the Hilti TE-YD or TE-CD Hollow Drill Bits, the DRS attachment system, or compressed air or a manual pump, h_{nom} is achieved at the specified value of h_o noted in [Table 1](#). The anchor must be hammered into the predrilled hole until h_{nom} is achieved. The nut must be tightened against the washer until the torque values specified in [Table 1](#) are achieved, or the anchors may be installed using the appropriate Hilti Impact Wrench and corresponding Hilti AT Module in accordance with [Figure 7](#). The Hilti AT Tool system is not permitted for use with the 1/4-inch and 1-inch diameter KB-TZ2 anchors. For installation in the soffit of concrete on steel deck assemblies, the hole diameter in the steel deck must not exceed the diameter of the hole in the concrete by more than 1/8 inch (3.2 mm). For member thickness and edge distance restrictions for installations into the soffit of concrete on steel deck assemblies, [Figure 5A](#), [Figure 5B](#), [Figure 5C](#), [Figure 5D](#) and [Figure 5E](#).

4.3 Special Inspection:

Periodic special inspection is required in accordance with Section 1705.1.1 and Table 1705.3 of the 2024 IBC, as applicable. The special inspector must make periodic inspections during anchor installation to verify anchor type, anchor dimensions, concrete type, concrete compressive strength, anchor spacing, edge distances, concrete member thickness, tightening torque, hole dimensions, anchor embedment and adherence to the manufacturer's printed installation instructions. The special inspector must be present as often as required in accordance with the "statement of special inspection." Under the IBC, additional requirements as set forth in Sections 1705, 1706 and 1707 must be observed, where applicable.

5.0 CONDITIONS OF USE:

The Hilti KB-TZ2 anchors described in this report comply with the codes listed in Section 1.0 of this report, subject to the following conditions:

- 5.1 Anchor sizes, dimensions, minimum embedment depths and other installation parameters as set forth in this report.
- 5.2 The anchors must be installed in accordance with the manufacturer's published instructions and this report. In case of conflict, this report governs.
- 5.3 Anchors must be limited to use in cracked and uncracked normal-weight concrete and lightweight concrete having a specified compressive strength, f'_c , of 2,500 psi to 8,500 psi (17.2 MPa to 58.6 MPa), and cracked and uncracked normal-weight or sand-lightweight concrete over metal deck having a specified compressive strength, f'_c , of 3,000 psi to 8,500 psi (20.7 MPa to 58.6 MPa).
- 5.4 The values of f'_c used for calculation purposes must not exceed 8,000 psi (55.1 MPa).
- 5.5 The concrete shall have attained its minimum design strength prior to installation of the anchors.
- 5.6 Strength design values must be established in accordance with Section 4.1 of this report.

- 5.7 Allowable design values are established in accordance with Section 4.2.
- 5.8 Anchor spacing and edge distance as well as minimum member thickness must comply with [Tables 3](#) and [9](#), and [Figure 5A](#), [Figure 5B](#), [Figure 5C](#), [Figure 5D](#), [Figure 5E](#) and [Figure 5F](#).
- 5.9 Prior to installation, calculations and details demonstrating compliance with this report must be submitted to the code official. The calculations and details must be prepared by a registered design professional where required by the statutes of the jurisdiction in which the project is to be constructed.
- 5.10 Since an ICC-ES acceptance criteria for evaluating data to determine the performance of expansion anchors subjected to fatigue or shock loading is unavailable at this time, the use of these anchors under such conditions is beyond the scope of this report.
- 5.11 Anchors may be installed in regions of concrete where cracking has occurred or where analysis indicates cracking may occur ($f_t > f_r$), subject to the conditions of this report.
- 5.12 Anchors may be used to resist short-term loading due to wind or seismic forces in locations designated as Seismic Design Categories A through F of the IBC, subject to the conditions of this report.
- 5.13 Where not otherwise prohibited in the code, KB-TZ2 anchors are permitted for use with fire-resistance-rated construction provided that at least one of the following conditions is fulfilled:
- Anchors are used to resist wind or seismic forces only.
 - Anchors that support a fire-resistance-rated envelope or a fire-resistance-rated membrane are protected by approved fire-resistance-rated materials, or have been evaluated for resistance to fire exposure in accordance with recognized standards.
 - Anchors are used to support nonstructural elements.
- 5.14 Use of zinc-coated carbon steel anchors is limited to dry, interior locations.
- 5.15 Use of anchors made of stainless steel as specified in this report are permitted for exterior exposure and damp environments.
- 5.16 Use of anchors made of stainless steel as specified in this report are permitted for contact with preservative-treated and fire-retardant-treated wood.
- 5.17 Anchors are manufactured by Hilti AG under an approved quality-control program with inspections by ICC-ES.
- 5.18 Special inspection must be provided in accordance with Section 4.3.

6.0 EVIDENCE SUBMITTED

- 6.1 Data in accordance with the [ICC-ES Acceptance Criteria for Mechanical Anchors in Concrete Elements AC193 \(24a\)](#), published April 2025, which incorporates requirements in ACI 355.2-19 and ACI 355.2-07 for use in cracked and uncracked concrete.
- 6.2 Quality-control documentation.

7.0 IDENTIFICATION

- 7.1 The ICC-ES mark of conformity, electronic labeling, or the evaluation report number (ICC-ES ESR-4266) along with the name, registered trademark, or registered logo of the report holder must be included in the product label.
- 7.2 In addition, the anchors are identified by packaging labeled with the manufacturer's name (Hilti, Inc.) and contact information, anchor name, anchor size, and evaluation report number (ESR-4266). The anchors have the letters KB-TZ2 embossed on the anchor stud and a notch or notches embossed into the anchor head. The letters and notches are visible after installation for verification as depicted in [Figure 3](#) of this report. The number of notches indicate material type. The letter system indicating length embossed on the head of the anchor is described in [Table 2](#).
- 7.3 The report holder's contact information is the following:

HILTI, INC.
7250 DALLAS PARKWAY, SUITE 1000
PLANO, TEXAS 75024
(918) 872-8000
www.hilti.com

TABLE 1—SETTING INFORMATION

Setting information	Sym.	Unit s	Nominal anchor diameter (in.)															
			1/4	3/8		1/2			5/8			3/4			1			
Nominal bit diameter	d_o	In.	1/4	3/8		1/2			5/8			3/4			1			
Effective min. embedment	h_{ef}	In. (mm)	1-1/2 (38)	1-1/2 (38)	2 (51)	2-1/2 (64)	1-1/2 ¹ (38)	2 (51)	2-1/2 (64)	3-1/4 (83)	2-3/4 (70)	3-1/4 (83)	4 (102)	3-1/4 (83)	3-3/4 (95)	4-3/4 (121)	4 (102)	5-3/4 (146)
Nominal embedment	h_{nom}	in. (mm)	1-3/4 (44)	1-7/8 (48)	2-1/2 (64)	3 (76)	2 ¹ (51)	2-1/2 (64)	3 (76)	3-3/4 (95)	3-1/4 (83)	3-3/4 (95)	4-1/2 (114)	4 (102)	4-1/2 (114)	5-1/2 (140)	4-5/8 (117)	6-3/8 (162)
Min. hole depth	h_o	In. (mm)	2 (51)	2 (51)	2-3/4 (70)	3-1/4 (83)	2-1/4 ¹ (57)	2-3/4 (70)	3-1/4 (83)	4-1/4 (108)	3-3/4 (95)	4-1/4 (108)	4-3/4 (121)	4-1/4 (108)	4-3/4 (121)	5-3/4 (146)	5 (127)	6-3/4 (171)
Installation torque Carbon steel ¹	T_{inst}	ft-lb (Nm)	4 (5)	30 (41)		50 (68)			40 (54)			110 (149)			185 (251)			
Installation torque Stainless steel ¹	T_{inst}	ft-lb (Nm)	6 (8)	30 (41)		40 (54)			60 (81)			125 (169)			185 (251)			
Fixture hole diameter	d_h	In. (mm)	5/16 (7.9)	7/16 (11.1)		9/16 (14.3)			11/16 (17.5)			13/16 (20.6)			1-1/8 (28.6)			

¹ Design information for h_{ef} = 1-1/2 is only applicable to carbon steel (CS) KB-TZ2 bolts.

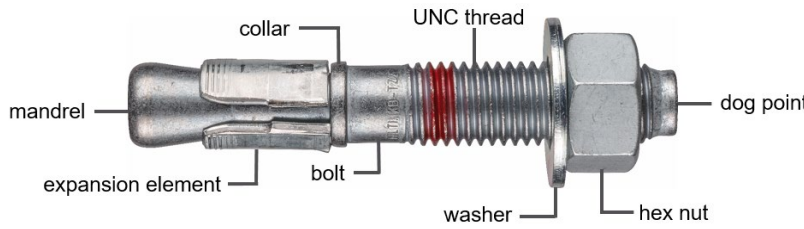

FIGURE 1—HILTI CARBON STEEL KWIK BOLT TZ (KB-TZ2)

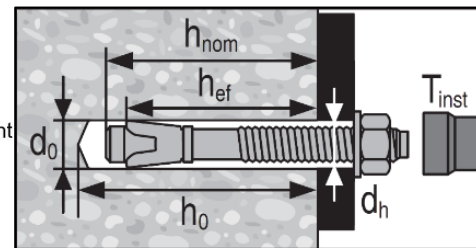

FIGURE 2—HILTI KB-TZ2 INSTALLED

TABLE 2—LENGTH IDENTIFICATION SYSTEM (CARBON STEEL AND STAINLESS STEEL ANCHORS)

Length ID marking on bolt head		A	B	C	D	E ¹	F	G	H	I	J	K	L	M	N	O	P	Q	R	S	T	U	V	W
Length of anchor, l_{anch} (inches)	From	1 1/2	2	2 1/2	3	3 1/2	4	4 1/2	5	5 1/2	6	6 1/2	7	7 1/2	8	8 1/2	9	9 1/2	10	11	12	13	14	15
	Up to but not including	2	2 1/2	3	3 1/2	4	4 1/2	5	5 1/2	6	6 1/2	7	7 1/2	8	8 1/2	9	9 1/2	10	11	12	13	14	15	16

For SI: 1 inch = 25.4 mm.

¹ 3/8 diameter anchors with length of 3 1/2 are identified with an ohm (Ω) ID marking on the bolt head.

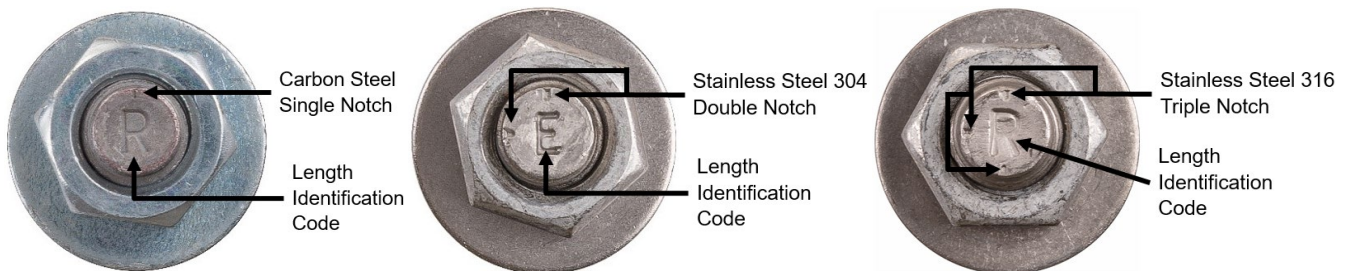

FIGURE 3—BOLT HEAD WITH LENGTH IDENTIFICATION CODE AND KB-TZ2 HEAD NOTCH EMBOSSEMENT

TABLE 3—MINIMUM EDGE DISTANCE, SPACING AND CONCRETE THICKNESS FOR KB-TZ2

Setting information	Symbol	Units	Nominal anchor dia. (in.)															
			1/4	3/8		1/2			5/8		3/4			1				
Effective min. embedment	h_{ef}	in. (mm)	1-1/2 (38)	1-1/2 (38)	2 (51)	2-1/2 (64)	1-1/2 (38)	2 (51)	2-1/2 (64)	3-1/4 (83)	2-3/4 (70)	3-1/4 (83)	4 (102)	3-1/4 (83)	3-3/4 (95)	4-3/4 (121)	4 (102)	5-3/4 (146)
Min. member thickness	h_{min}	in. (mm)	3-1/4 (83)	3-1/4 (83)	4 (102)	5 (127)	3-1/2 (89)	4 (102)	5 (127)	5-1/2 (140)	5 (127)	5-1/2 (140)	6 (152)	5-1/2 (140)	6 (152)	8 (203)	8 (203)	10 (254)
Carbon Steel																		
Min. edge distance	C_{min}	in. (mm)	1-1/2 (38)	5 (127)	2-1/2 (64)	2-1/2 (64)	8 (203)	2-3/4 (70)	2-3/4 (70)	2-1/4 (57)	4-1/2 (114)	3-1/2 (89)	2-3/4 (70)	5 (127)	4 (102)	3-1/2 (89)	8 (203)	3 (76)
	for $s \geq$	in. (mm)	1-1/2 (38)	8 (203)	6 (152)	5 (127)	12 (305)	5-1/2 (140)	9-3/4 (248)	5-1/4 (133)	6-1/2 (165)	5-1/2 (140)	7-1/4 (184)	10 (254)	5-3/4 (146)	5-1/2 (140)	8 (203)	6-3/4 (171)
Min. anchor spacing	S_{min}	in. (mm)	1-1/2 (38)	5 (127)	2-1/4 (57)	2 (51)	12 (305)	3-1/2 (89)	3 (76)	2 (51)	4-1/2 (114)	2-3/4 (70)	2-1/4 (57)	4-1/2 (114)	3-3/4 (95)	3-3/4 (95)	8 (203)	4-3/4 (121)
	for $c \geq$	in. (mm)	1-1/2 (38)	8 (203)	3-1/2 (89)	4 (102)	8 (203)	10 (254)	8 (203)	4-3/4 (121)	5-1/2 (140)	7 (178)	4-1/4 (108)	6 (152)	7-1/4 (184)	4-3/4 (121)	8 (203)	3-3/4 (95)
Stainless Steel																		
Min. edge distance	C_{min}	in. (mm)	1-1/2 (38)	5 (127)	2-1/2 (64)	2-1/2 (64)		2-3/4 (70)	2-1/2 (64)	2-1/4 (57)	4 (102)	3-1/4 (83)	2-1/4 (57)	5 (127)	4 (102)	3-3/4 (95)	3-3/4 (95)	3 (76)
	for $s \geq$	in. (mm)	1-1/2 (38)	8 (203)	5 (127)	5 (127)		5-1/2 (140)	4-1/2 (114)	5-1/4 (133)	7 (178)	5-1/2 (140)	7 (178)	11 (279)	7-1/2 (191)	5-3/4 (146)	10 (254)	6-3/4 (171)
Min. anchor spacing	S_{min}	in. (mm)	1-1/2 (38)	5 (127)	2-1/4 (57)	2-1/4 (57)		2-3/4 (70)	2-1/2 (64)	2 (51)	5-1/2 (140)	2-3/4 (70)	3 (76)	5 (127)	4 (102)	4 (102)	5 (127)	4-3/4 (121)
	for $c \geq$	in. (mm)	1-1/2 (38)	8 (203)	4 (102)	3-1/2 (89)		4-1/8 (105)	4-1/2 (114)	4-1/2 (114)	5-1/2 (140)	4 (102)	4-1/4 (108)	8 (203)	6 (152)	5-1/4 (133)	4-1/4 (108)	3-3/4 (95)

For SI: 1 inch = 25.4 mm

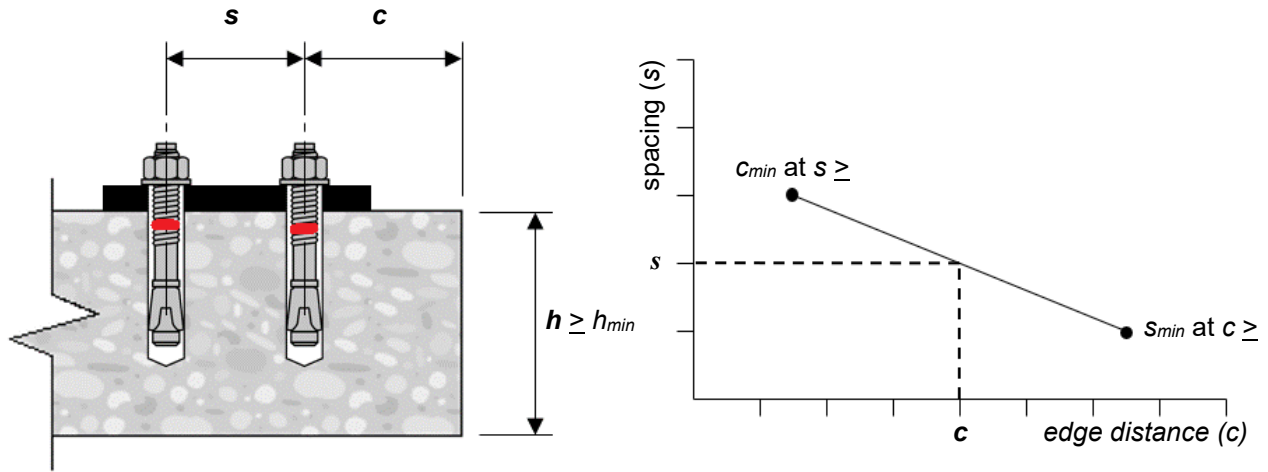

FIGURE 4—INTERPOLATION OF MINIMUM EDGE DISTANCE AND ANCHOR SPACING

TABLE 4—HILTI CARBON STEEL KB-T22 DESIGN INFORMATION FOR HAMMER AND CORE DRILLED INSTALLATIONS, TENSION⁷

Design parameter	Symbol	Units	Nominal anchor diameter (in)																		
			1/4		3/8		1/2			5/8		3/4			1						
Effective min. embedment ¹	h_{ef}	in. (mm)	1-1/2 (38)	1-1/2 (38)	2 (51)	2-1/2 (64)	1-1/2 (38)	2 (51)	2-1/2 (64)	3-1/4 (83)	2-3/4 (70)	3-1/4 (83)	4 (102)	3-1/4 (83)	3-3/4 (95)	4-3/4 (121)	4 (102)	5-3/4 (146)			
Tension, steel failure modes																					
Strength reduction factor for steel in tension ^{2,3}	$\Phi_{sa,N}$	-	0.75	0.75		0.75			0.75		0.75			0.75		0.75					
Min. specified yield strength	f_y	lb/in ² (N/mm ²)	100,900 (696)	100,900 (696)		96,300 (664)			87,000 (600)		84,700 (584)			75,000 (517)							
Min. specified ult. strength	f_{uta}	lb/in ² (N/mm ²)	122,400 (844)	126,200 (870)		114,000 (786)			106,700 (736)		105,900 (730)			88,000 (607)							
Effective tensile stress area	$A_{se,N}$	in ² (mm ²)	0.024 (15.4)	0.051 (33.2)		0.099 (63.6)			0.164 (106.0)		0.239 (154.4)			0.470 (303.2)							
Steel strength in tension	N_{sa}	lb (kN)	2,920 (13.0)	6,490 (28.9)		11,240 (50.0)			17,535 (78.0)		25,335 (112.7)			41,365 (184.1)							
Tension, concrete failure modes																					
Anchor category	-	-	3	1		1			1		1			1							
Strength reduction factor for concrete and pullout failure in tension ³	$\Phi_{c,N}$ $\Phi_{p,N}$	-	0.45	0.65		0.65			0.65		0.65			0.65							
Effectiveness factor for uncracked concrete	k_{uncr}	-	24	24		27		24		24		27		27 ⁶		24		27		24	
Effectiveness factor for cracked concrete	k_{cr}	-	17	21		17		24		21		17		21		21		21			
Modification factor for anchor resistance, tension, uncracked concrete ⁴	$\Psi_{c,N}$	-	1.0	1.0		1.0			1.0		1.0			1.0		1.0					
Critical edge distance	c_{ac}	in. (mm)	4 (102)	5 (127)	4-3/8 (111)	5-1/2 (140)	8 (203)	5-1/2 (140)	6-3/4 (171)	10 (254)	10 (254)	11-1/2 (292)	8-3/4 (222)	12 (305)	10 (254)	9 (229)	11 (279)	16 (406)			
Pullout strength uncracked conc. ⁵	$N_{p,uncr}$	lb (kN)	2,100 (9.3)	N/A	N/A	4,180 (18.6)	N/A	N/A	N/A	N/A	5,380 (23.9)	N/A	8,995 (40.0)	N/A	N/A	N/A	N/A	N/A			
Pullout strength cracked conc. ⁵	$N_{p,cr}$	lb (kN)	625 (2.8)	N/A	N/A	N/A	N/A	N/A	N/A	N/A	N/A	N/A	N/A	N/A	N/A	8,835 (39.3)	N/A	11,810 (52.6)			
Pullout strength seismic ⁵	$N_{p,eq}$	lb (kN)	625 (2.8)	N/A	N/A	N/A	N/A	N/A	N/A	N/A	N/A	N/A	N/A	N/A	N/A	8,700 (38.7)	N/A	11,810 (52.6)			
Normalization factor, uncracked concrete	n_{uncr}	-	0.20	0.22	0.24	0.35	0.50	0.42	0.29	0.35	0.50	0.48	0.50	0.35	0.31	0.39	N/A	0.38			
Normalization factor, cracked concrete, seismic	n_{cr}	-	0.39	0.50	0.46	0.28	0.47	0.50	0.48	0.40	0.50	0.47	0.50	0.36	0.42	0.29	N/A	0.50			
Tension, axial stiffness																					
Axial stiffness in service load range	β_{uncr}	lb/in.	322,360		131,570			158,585			290,360		412,335			199,845					
	β_{cr}	lb/in.	31,035		91,335			113,515			167,365		62,180			122,400					

For **S1**: 1 inch = 25.4 mm, 1 lbf = 4.45 N, 1 psi = 0.006895 MPa. For pound-inch units: 1 mm = 0.03937 inches.

¹ Figure 2 of this report illustrates the installation parameters.
² The KB-T22 is considered a ductile steel element in accordance with ACI 318-19 2.3.
³ The strength reduction factor applies when the load combinations from the IBC or ACI 318 are used and the requirements of ACI 318-19 17.5.3 are met. The strength reduction factors are applicable with supplementary reinforcement is not present. Greater strength reduction factors may be used in areas where supplementary reinforcement can be verified.
⁴ For all design cases, $\Psi_{c,N} = 1.0$. The appropriate effectiveness factor for cracked concrete (k_{cr}) or uncracked concrete (k_{uncr}) must be used.
⁵ For all design cases, $\Psi_{c,P} = 1.0$. Tabular value for pullout strength is for a concrete compressive strength of 2,500 psi (17.2 MPa). Pullout strength for concrete compressive strength greater than 2,500 psi (17.2 MPa) may be increased by multiplying the tabular pullout strength by $(f_c / 2,500)^n$ for psi, or $(f_c / 17.2)^n$ for MPa, where n is given as n_{uncr} for uncracked concrete and n_{cr} for cracked concrete and seismic. NA (not applicable) denotes that pullout strength does not need to be considered for design.
⁶ For core drill installations, $k_{uncr} = 24$ for 3/4-inch diameter anchors installed at 3 3/4 inches (95 mm) effective embedment.
⁷ 1/4-inch and 1-inch diameter anchors are not permitted for core drilling installations.

TABLE 5—HILTI STAINLESS STEEL KB-TZ2 DESIGN INFORMATION FOR HAMMER AND CORE DRILLED INSTALLATIONS, TENSION⁸

Design parameter	Symbol	Units	Nominal anchor diameter (in)														
			1/4		3/8		1/2			5/8			3/4			1	
Effective min. embedment ¹	h_{ef}	in. (mm)	1-1/2 (38)	1-1/2 (38)	2 (51)	2-1/2 (64)	2 (51)	2-1/2 (64)	3-1/4 (83)	2-3/4 (70)	3-1/4 (83)	4 (102)	3-1/4 (83)	3-3/4 (95)	4-3/4 (121)	4 (102)	5-3/4 (146)
Tension, steel failure modes																	
Strength reduction factor for steel in tension ^{2,3}	$\Phi_{sa,N}$	-	0.75	0.75		0.75			0.75			0.75			0.75		
Min. specified yield strength	f_y	lb/in ² (N/mm ²)	100,900 (696)	96,300 (664)		96,300 (664)			91,600 (632)			84,100 (580)			65,000 (448)		
Min. specified ult. strength	f_{uta}	lb/in ² (N/mm ²)	122,400 (844)	120,100 (828)		120,400 (830)			114,600 (790)			100,500 (693)			99,900 (689)		
Effective tensile stress area	$A_{se,N}$	ln ² (mm ²)	0.024 (15.4)	0.051 (33.2)		0.099 (63.6)			0.164 (106.0)			0.239 (154.4)			0.470 (303.2)		
Steel strength in tension	N_{sa}	lb (kN)	2,920 (13.0)	6,180 (27.5)		11,870 (52.8)			18,835 (83.8)			24,045 (107.0)			46,955 (208.9)		
Tension, concrete failure modes																	
Anchor category	-	-	3	1		1			1			1			1		
Strength reduction factor for concrete and pullout failure in tension, (Condition B – supplementary reinforcement not present) ³	$\Phi_{c,N}, \Phi_{p,N}$	-	0.45	0.65		0.65			0.65			0.65			0.65		
Effectiveness factor for uncracked concrete	k_{uncr}	-	24	24		24			24			24	27 ⁶	24	27		
Effectiveness factor for cracked concrete	k_{cr}	-	17	21	17	17	21	17	21	17	21	17	21	21 ⁶	21	24	21
Modification factor for anchor resistance, tension, uncracked concrete ⁴	$\Psi_{c,N}$	-	1.0	1.0		1.0			1.0			1.0			1.0		
Critical edge distance	c_{ac}	in. (mm)	4 (102)	4-1/2 (114)	5-1/2 (140)	4-1/8 (105)	5-1/2 (140)	6-1/4 (159)	7-1/2 (191)	10 (254)	6-1/2 (165)	8-3/4 (222)	12 (305)	10 (254)	10 (254)	11 (279)	15-1/2 (394)
Pullout strength uncracked concrete ⁵	$N_{p,uncr}$	lb (kN)	1,570 (7.0)	N/A	N/A	4,185 (18.6)	3,380 (15.0)	4,010 (17.8)	5,500 (24.5)	4,085 (18.2)	6,015 (26.8)	8,050 (35.8)	N/A	N/A	N/A	N/A	N/A
Pullout strength cracked concrete ⁵	$N_{p,cr}$	lb (kN)	670 (3.0)	N/A	N/A	N/A	N/A	N/A	N/A ⁷	N/A	N/A	N/A	N/A	N/A	8,795 (39.1)	N/A	N/A
Pullout strength seismic ⁵	$N_{p,eq}$	lb (kN)	670 (3.0)	N/A	N/A	N/A	N/A	N/A	N/A ⁷	N/A	N/A	N/A	N/A	N/A	8,795 (39.1)	N/A	N/A
Normalization factor, uncracked concrete	n_{uncr}	-	0.39	N/A	N/A	0.37	0.46	0.50	0.50	0.50	0.42	0.47	N/A	N/A	0.30	N/A	N/A
Normalization factor, cracked concrete, seismic	n_{cr}	-	0.50	N/A	N/A	N/A	N/A	N/A	0.50	N/A	N/A	N/A	N/A	N/A	0.50	N/A	N/A
Tension, axial stiffness																	
Axial stiffness in service load range	β_{uncr}	lb/in.	166,490	175,800		137,145			153,925			342,680			105,970		
	β_{cr}	lb/in.	33,805	79,860		97,985			69,625			75,715			117,630		

For SI: 1 inch = 25.4 mm, 1 lbf = 4.45 N, 1 psi = 0.006895 MPa For pound-inch units: 1 mm = 0.03937 inches.

¹ Figure 2 of this report illustrates the installation parameters.

² The KB-TZ2 is considered a ductile steel element in accordance with ACI 318-19 2.3.

³ The strength reduction factor applies when the load combinations from the IBC or ACI 318 are used and the requirements of ACI 318-19 17.5.3 are met. The strength reduction factors are applicable with supplementary reinforcement is not present. Greater strength reduction factors may be used in areas where supplementary reinforcement can be verified.

⁴ For all design cases, $\Psi_{c,N} = 1.0$. The appropriate effectiveness factor for cracked concrete (k_{cr}) or uncracked concrete (k_{uncr}) must be used.

⁵ For all design cases, $\Psi_{c,P} = 1.0$. Tabular value for pullout strength is for a concrete compressive strength of 2,500 psi (17.2 MPa). Pullout strength for concrete compressive strength greater than 2,500 psi (17.2 MPa) may be increased by multiplying the tabular pullout strength by $(f'_c / 2,500)^n$ for psi, or $(f'_c / 17.2)^n$ for MPa, where n is given as n_{uncr} for uncracked concrete and n_{cr} for cracked concrete. NA (not applicable) denotes that pullout strength does not need to be considered for design.

⁶ For core drill installations, $k_{uncr} = 24$ and $k_{cr} = 17$ for 3/4-inch diameter anchors installed at 3 3/4 inches (95 mm) effective embedment.

⁷ For core drill installations, $N_{p,cr} = 4245$ lb (18.9 kN) and $N_{p,eq} = 4245$ lb (18.9 kN) for 1/2-inch diameter anchors installed at 3 1/4 inches (83 mm) effective embedment.

⁸ 1/4-inch and 1-inch diameter anchors are not permitted for core drilling installations.

TABLE 6—HILTI CARBON STEEL KB-TZ2 DESIGN INFORMATION FOR HAMMER AND CORE DRILLED INSTALLATIONS, SHEAR⁴

Design parameter	Symbol	Units	Nominal anchor diameter (in)															
			1/4		3/8		1/2			5/8			3/4			1		
Anchor O.D.	d_a	in. (mm)	0.250 (6.4)	0.375 (9.5)		0.500 (12.7)			0.625 (15.9)			0.750 (19.1)			1.00 (25.4)			
Effective min. embedment ¹	h_{ef}	in. (mm)	1-1/2 (38)	1-1/2 (38)	2 (51)	2-1/2 (64)	1-1/2 (38)	2 (51)	2-1/2 (64)	3-1/4 (83)	2-3/4 (70)	3-1/4 (83)	4 (102)	3-1/4 (83)	3-3/4 (95)	4-3/4 (121)	4 (102)	5-3/4 (146)
Shear, steel failure modes																		
Strength reduction factor for steel in shear ^{2,3}	$\Phi_{sa,v}$	-	0.65	0.65		0.65			0.65			0.65			0.65			
Steel strength in shear	V_{sa}	lb (kN)	1,345 (6.0)	3,225 (14.4)	3,385 (15.1)	5,535 (24.6)		6,875 (30.6)		10,255 (45.6)			13,805 (61.4)			18,795 (83.6)	22,825 (101.6)	
Steel strength in shear, seismic	$V_{sa,eq}$	lb (kN)	1,345 (6.0)	3,225 (14.4)	3,385 (15.1)	5,535 (24.6)		6,875 (30.6)		10,255 (45.6)			13,805 (61.4)			13,805 (61.4)		
Shear, concrete failure modes																		
Strength reduction factor for concrete breakout and pryout failure in shear, (Condition B – supplementary reinforcement not present) ³	$\Phi_{c,v}, \Phi_{p,v}$	-	0.70	0.70		0.70			0.70			0.70			0.70			
Load bearing length of anchor in shear	l_e	in. (mm)	1-1/2 (38)	1-1/2 (38)	2 (51)	2-1/2 (64)	1-1/2 (38)	2 (51)	2-1/2 (64)	3-1/4 (83)	2-3/4 (70)	3-1/4 (83)	4 (102)	3-1/4 (83)	3-3/4 (95)	4-3/4 (121)	4 (102)	5-3/4 (146)
Coefficient for pryout strength	k_{cp}	-	1	1	1	2	1	1	2	2	2	2	2	2	2	2	2	2

For SI: 1 inch = 25.4 mm, 1 lbf = 4.45 N, 1 psi = 0.006895 MPa For pound-inch units: 1 mm = 0.03937 inches.

¹ Figure 2 of this report illustrates the installation parameters.

² The KB-TZ2 is considered a ductile steel element in accordance with ACI 318-19 2.3.

³ The strength reduction factor applies when the load combinations from the IBC or ACI 318 are used and the requirements of ACI 318-19 17.5.3 are met. The strength reduction factors are applicable with supplementary reinforcement is not present. Greater strength reduction factors may be used in areas where supplementary reinforcement can be verified.

⁴ 1/4-inch and 1-inch diameter anchors are not permitted for core drilling installations.

TABLE 7—HILTI STAINLESS STEEL KB-TZ2 DESIGN INFORMATION FOR HAMMER AND CORE DRILLED INSTALLATIONS, SHEAR⁴

Design parameter	Symbol	Units	Nominal anchor diameter															
			1/4		3/8		1/2			5/8			3/4			1		
Anchor O.D.	d_a	in. (mm)	0.250 (6.4)	0.375 (9.5)		0.500 (12.7)			0.625 (15.9)			0.750 (19.1)			1.00 (25.4)			
Effective min. embedment ¹	h_{ef}	in. (mm)	1-1/2 (38)	1-1/2 (38)	2 (51)	2-1/2 (64)	2 (51)	2-1/2 (64)	3-1/4 (83)	2-3/4 (70)	3-1/4 (83)	4 (102)	3-1/4 (83)	3-3/4 (95)	4-3/4 (121)	4 (102)	5-3/4 (146)	
Shear, steel failure modes																		
Strength reduction factor for steel in shear ^{2,3}	$\Phi_{sa,v}$	-	0.65	0.65		0.65			0.65			0.65			0.65			
Steel strength in shear	V_{sa}	lb (kN)	1,460 (6.5)	4,615 (20.5)	4,885 (21.7)	8,345 (37.1)		12,355 (55.0)		16,560 (73.7)			22,955 (102.1)		31,400 (139.7)			
Steel strength in shear, seismic	$V_{sa,eq}$	lb (kN)	1,110 (4.9)	4,615 (20.5)	4,885 (21.7)	8,345 (37.1)		12,355 (55.0)		13,470 (59.9)			13,470 (59.9)					
Shear, concrete failure modes																		
Strength reduction factor for concrete breakout and pryout failure in shear, (Condition B – supplementary reinforcement not present) ³	$\Phi_{c,v}, \Phi_{p,v}$	-	0.7	0.7		0.7			0.7			0.7			0.7			
Load bearing length of anchor in shear	l_e	in. (mm)	1-1/2 (38)	1-1/2 (38)	2 (51)	2-1/2 (64)	2 (51)	2-1/2 (64)	3-1/4 (83)	2-3/4 (70)	3-1/4 (83)	4 (102)	3-1/4 (83)	3-3/4 (95)	4-3/4 (121)	4 (102)	5-3/4 (146)	
Coefficient for pryout strength	k_{cp}	-	1	1	1	2	1	2	2	2	2	2	2	2	2	2	2	

For SI: 1 inch = 25.4 mm, 1 lbf = 4.45 N, 1 psi = 0.006895 MPa For pound-inch units: 1 mm = 0.03937 inches.

¹ Figure 2 of this report illustrates the installation parameters.

² The KB-TZ2 is considered a ductile steel element in accordance with ACI 318-19 2.3.

³ The strength reduction factor applies when the load combinations from the IBC or ACI 318 are used and the requirements of ACI 318-19 17.5.3 are met. The strength reduction factors are applicable with supplementary reinforcement is not present. Greater strength reduction factors may be used in areas where supplementary reinforcement can be verified.

⁴ 1/4-inch and 1-inch diameter anchors are not permitted for core drilling installations.

TABLE 8—HILTI KB-TZ2 CARBON STEEL ANCHORS TENSION AND SHEAR DESIGN DATA FOR INSTALLATION IN THE SOFFIT OF 3000 PSI, LIGHTWEIGHT CONCRETE-FILLED PROFILE STEEL DECK ASSEMBLIES FOR HAMMER AND CORE DRILLED INSTALLATIONS^{1,2,3}

Design parameter	Symbol	Units	Anchor Diameter											
			1/4	3/8		1/2			5/8		3/4			
Effective min. embedment ¹	h_{ef}	in.	1-1/2	1-1/2	2	2-1/2	1-1/2	2	2-1/2	3-1/4 ¹⁰	2-3/4	4 ¹⁰	3-1/4 ¹⁰	3-3/4 ⁹
Minimum hole depth	h_o	in.	2	2	2-3/4	3-1/4	2-1/4	2-3/4	3-1/4	4-1/4	3-3/4	4-3/4	4-1/4	4-3/4
Loads According to Figure 5A														
Minimum concrete thickness over upper flute ⁴	$h_{min,deck}$	in.	2-1/2	2-1/2		2-1/2 ¹⁰			2-1/2 ¹⁰		2-1/2 ¹⁰	3-1/4		
Pullout strength, uncracked concrete ^{5,6}	$N_{p,deck,uncr}$	lb	1,725	1,855	2,625	2,995	1,855	2,750	3,745	4,715	4,415	5,815	3,800	4,795
Pullout strength, cracked concrete ^{5,6}	$N_{p,deck,cr}$	lb	515	1,625	2,295	2,405	1,650	2,135	3,275	3,340	3,930	4,395	3,325	3,730
Pullout strength, seismic ^{5,7}	$N_{p,deck,eq}$	lb	515	1,625	2,295	2,405	1,650	2,135	3,275	3,340	3,930	4,395	3,325	3,730
Steel strength in shear ⁸	$V_{sa,deck}$	lb	1,630	1,355	2,120	2,120	1,790	2,260	3,555	4,345	3,815	6,150	4,085	7,865
Steel strength in shear, seismic ⁷	$V_{sa,deck,eq}$	lb	1,630	1,355	2,120	2,120	1,790	2,260	3,555	4,345	3,815	6,150	4,085	7,865
Loads According to Figure 5B														
Minimum concrete thickness over upper flute ⁴	$h_{min,deck}$	in.	2-1/2	2-1/2		2-1/2 ¹⁰			2-1/2 ¹⁰		2-1/2 ¹⁰	3-1/4		
Pullout strength, uncracked concrete ^{5,6}	$N_{p,deck,uncr}$	lb	1,725	1,855	2,625	2,995	1,855	2,750	3,745	4,715	4,415	5,815	3,800	4,795
Pullout strength, cracked concrete ^{5,6}	$N_{p,deck,cr}$	lb	515	1,625	2,295	2,405	1,650	2,135	3,275	3,340	3,930	4,395	3,325	3,730
Pullout strength, seismic ^{5,7}	$N_{p,deck,eq}$	lb	515	1,625	2,295	2,405	1,650	2,135	3,275	3,340	3,930	4,395	3,325	3,730
Steel strength in shear ⁸	$V_{sa,deck}$	lb	1,630	1,355	2,120	2,120	1,790	2,260	3,285	4,235	3,815	4,650	4,085	7,865
Steel strength in shear, seismic ⁷	$V_{sa,deck,eq}$	lb	1,630	1,355	2,120	2,120	1,790	2,260	3,285	4,235	3,815	4,650	4,085	7,865
Loads According to Figure 5C														
Minimum concrete thickness over upper flute ⁴	$h_{min,deck}$	in.	2-1/4	2-1/4		N/A		2-1/4		N/A	3-1/4	3-1/4	N/A	N/A
Pullout strength, uncracked concrete ^{5,6}	$N_{p,deck,uncr}$	lb	1,380	990	2,485	N/A		1,815	1,900	N/A	2,665	2,960	N/A	N/A
Pullout strength, cracked concrete ^{5,6}	$N_{p,deck,cr}$	lb	410	870	2,130	N/A		1,480	1,480	N/A	1,890	2,635	N/A	N/A
Pullout strength, seismic ^{5,7}	$N_{p,deck,eq}$	lb	410	870	2,130	N/A		1,480	1,480	N/A	1,890	2,635	N/A	N/A
Steel strength in shear ⁸	$V_{sa,deck}$	lb	1,125	2,370	2,505	N/A		2,680	3,175	N/A	3,465	4,085	N/A	N/A
Steel strength in shear, seismic ⁷	$V_{sa,deck,eq}$	lb	1,125	2,370	2,505	N/A		2,680	3,175	N/A	3,465	4,085	N/A	N/A
Loads According to Figure 5D														
Minimum concrete thickness over upper flute ⁴	$h_{min,deck}$	in.	N/A	2	N/A	N/A	N/A	2	N/A	N/A	N/A	N/A	N/A	N/A
Pullout strength, uncracked concrete ^{5,6}	$N_{p,deck,uncr}$	lb	N/A	2,315	N/A	N/A	N/A	2,545	N/A	N/A	N/A	N/A	N/A	N/A
Pullout strength, cracked concrete ^{5,6}	$N_{p,deck,cr}$	lb	N/A	2,035	N/A	N/A	N/A	1,975	N/A	N/A	N/A	N/A	N/A	N/A
Pullout strength, seismic ^{5,7}	$N_{p,deck,eq}$	lb	N/A	2,035	N/A	N/A	N/A	1,975	N/A	N/A	N/A	N/A	N/A	N/A
Steel strength in shear ⁸	$V_{sa,deck}$	lb	N/A	2,220	N/A	N/A	N/A	3,180	N/A	N/A	N/A	N/A	N/A	N/A
Steel strength in shear, seismic ⁷	$V_{sa,deck,eq}$	lb	N/A	2,220	N/A	N/A	N/A	3,180	N/A	N/A	N/A	N/A	N/A	N/A
Loads According to Figure 5E														
Minimum concrete thickness over upper flute ⁴	$h_{min,deck}$	in.	N/A	2	N/A	N/A	N/A	2	N/A	N/A	N/A	N/A	N/A	N/A
Pullout strength, uncracked concrete ^{5,6}	$N_{p,deck,uncr}$	lb	N/A	1,580	N/A	N/A	N/A	1,695	N/A	N/A	N/A	N/A	N/A	N/A
Pullout strength, cracked concrete ^{5,6}	$N_{p,deck,cr}$	lb	N/A	1,385	N/A	N/A	N/A	1,315	N/A	N/A	N/A	N/A	N/A	N/A
Pullout strength, seismic ^{5,7}	$N_{p,deck,eq}$	lb	N/A	1,385	N/A	N/A	N/A	1,315	N/A	N/A	N/A	N/A	N/A	N/A
Steel strength in shear ⁸	$V_{sa,deck}$	lb	N/A	2,320	N/A	N/A	N/A	2,795	N/A	N/A	N/A	N/A	N/A	N/A
Steel strength in shear, seismic ⁷	$V_{sa,deck,eq}$	lb	N/A	2,320	N/A	N/A	N/A	2,795	N/A	N/A	N/A	N/A	N/A	N/A

¹ Installations must comply with Section 4.1.9 and Section 4.3 and Figure 5A, Figure 5B, Figure 5C, Figure 5D, Figure 5E of this report.

² The values for $\phi_{p,N}$ in tension can be found in Table 4 of this report. The values for $\phi_{sa,V}$ in shear can be found in Table 6 of this report.

³ Evaluation of concrete breakout capacity in accordance with ACI 318-19 17.6.2 is not required for anchors installed in the deck soffit.

⁴ Minimum concrete thickness refers to concrete thickness above upper flute. See Figures 5A to 5E.

⁵ Characteristic pullout resistance for concrete compressive strengths greater than 3,000 psi (20.7 MPa) may be increased by multiplying the value in the table by $(f'c / 3000)^{0.5}$ for psi or $(f'c / 20.7)^{0.5}$ for MPa. See Table 4 for normalization factor.

⁶ The values listed must be used in accordance with Section 4.1.4 of this report.

⁷ The values listed must be used in accordance with Sections 4.1.4 and 4.1.8 of this report.

⁸ The values listed must be used in accordance with Section 4.1.5 of this report.

⁹ For core drill installations, with 3/4-inch diameter anchors installed at 3 3/4 inches (95 mm) effective embedment, apply a reduction factor of 0.89 to the design tension strength of anchors installed in uncracked concrete.

¹⁰ For 2" W-deck, the concrete thickness must be increased to 3-1/4" above the upper flute.

TABLE 9—HILTI KB-TZ2 CARBON STEEL ANCHORS SETTING INFORMATION FOR INSTALLATION ON THE TOP OF CONCRETE-FILLED PROFILE STEEL DECK ASSEMBLIES ACCORDING TO [FIGURE 5F](#) ^{1,2,3}

Design Information	Symbol	Units	Nominal anchor diameter (in.)							
			1/4		3/8		1/2			
Effective Embedment Depth	h_{ef}	in. (mm)	1-1/2 (38)	1-1/2 (38)	2 (51)		1-1/2 (38)	2 (51)		
Nominal Embedment Depth	h_{nom}	in. (mm)	1-3/4 (44)	1-7/8 (48)	2-1/2 (64)		2 (51)	2-1/2 (64)		
Minimum Hole Depth	h_o	in. (mm)	2 (51)	2 (51)	2-1/2 (64)	2-3/4 (70)	2-1/4 (57)		2-3/4 (70)	
Minimum Concrete Thickness ⁴	$h_{min,deck}$	in. (mm)	2-1/2 (64)	2-1/2 (64)	2-1/2 (64)	3-1/4 (83)	2-1/2 (64)	3-1/4 (83)	3-1/4 (83)	
Critical Edge Distance	$C_{ac, deck, top}$	in. (mm)	5 (127)	16 (408)	8 (204)	6 (152)	7-1/2 (191)	12 (305)	7-1/2 (191)	
Minimum Edge Distance	$C_{min, deck, top}$	in. (mm)	3 (76)	16 (408)	8 (204)	6 (152)	7-1/2 (191)	12 (305)	7-1/2 (191)	8 (204)
Minimum Spacing	$S_{min, deck, top}$	in. (mm)	3 (76)	8 (204)	6 (152)	4 (102)	9 (229)	6 (152)	9 (229)	6 (152)
Required Installation Torque	T_{inst}	ft-lb (Nm)	4 (5)	30 (41)			50 (68)			

¹ Installations must comply with Section 4.1.10 and Section 4.3 and [Figure 5F](#) of this report.

² Design capacity shall be based on calculations according to values in [Tables 4](#) and [6](#) of this report.

³ Applicable for $h_{min,deck} < h_{min}$, [Table 3](#). For $h_{min,deck} \geq h_{min}$, [Table 3](#), use setting information in [Tables 1](#) and [3](#) and critical edge distances in [Table 4](#) of this report.

⁴ Minimum concrete thickness refers to concrete thickness above the upper flute. See [Figure 5F](#).

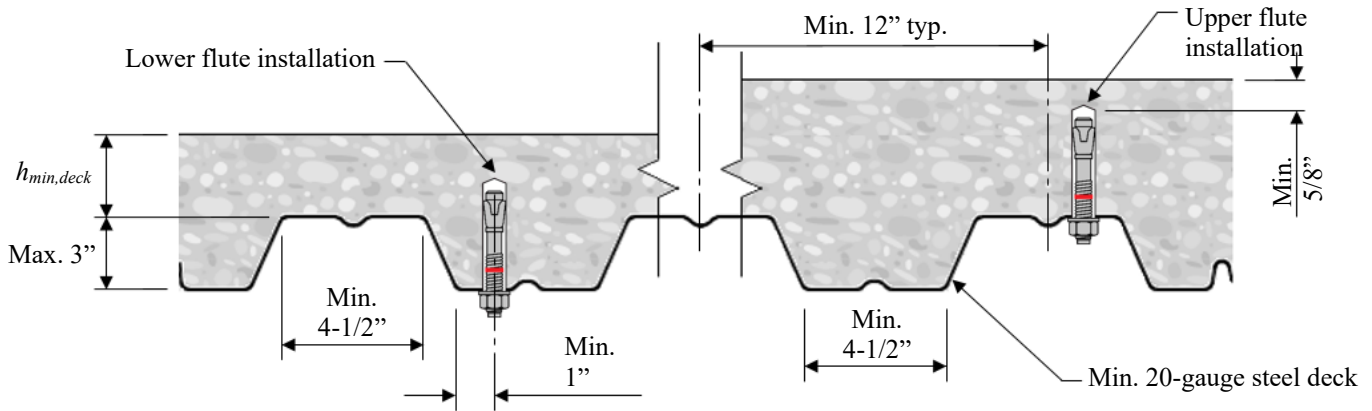

FIGURE 5A—KB-TZ2 IN THE SOFFIT OF CONCRETE FILLED PROFILE STEEL DECK ASSEMBLIES – W DECK

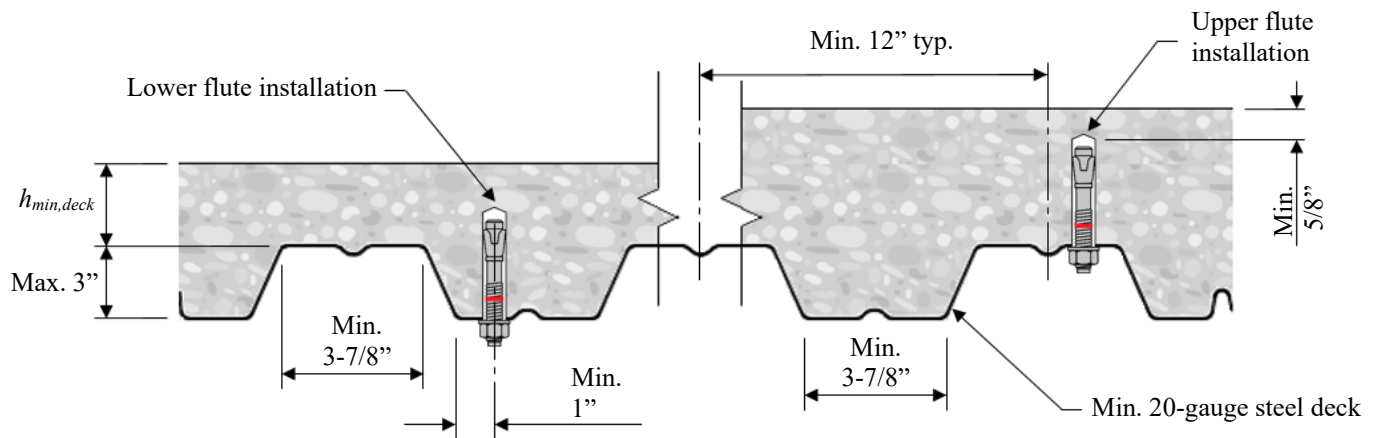

FIGURE 5B—KB-TZ2 IN THE SOFFIT OF CONCRETE FILLED PROFILE STEEL DECK ASSEMBLIES – W DECK

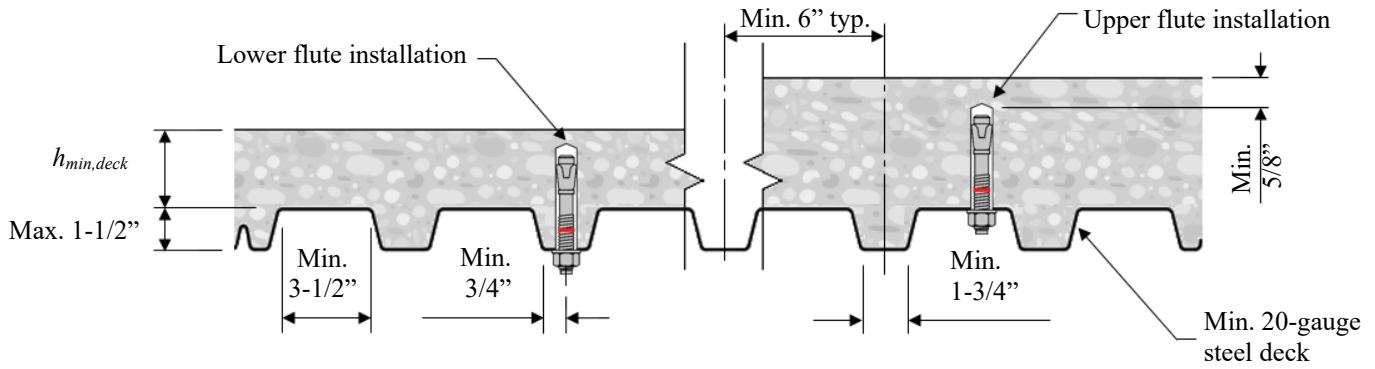

FIGURE 5C—KB-TZ2 IN THE SOFFIT OF CONCRETE FILLED PROFILE STEEL DECK ASSEMBLIES – B DECK

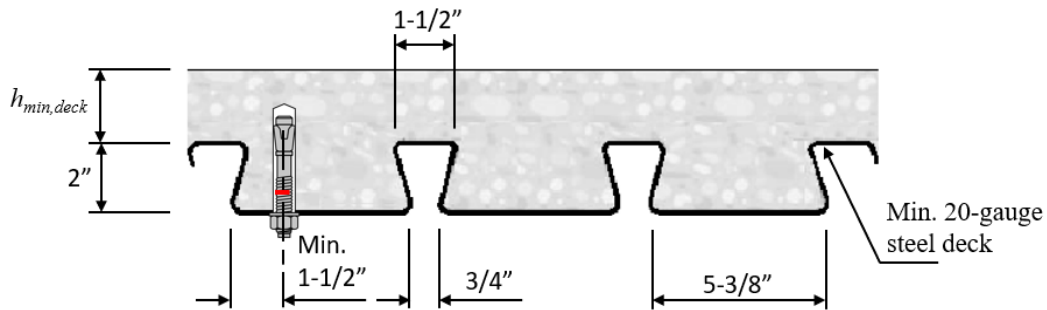

FIGURE 5D— KB-TZ2 IN THE SOFFIT OF CONCRETE FILLED PROFILE STEEL DECK ASSEMBLIES – 2" DOVETAIL DECK

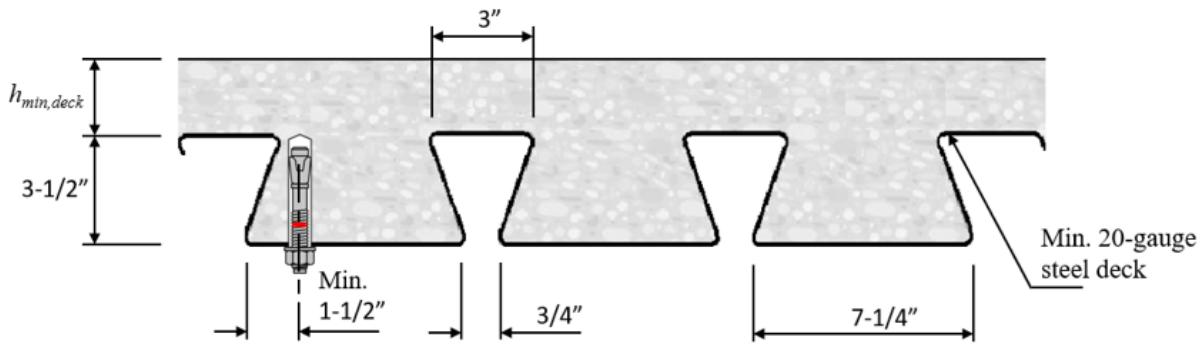

FIGURE 5E— KB-TZ2 IN THE SOFFIT OF CONCRETE FILLED PROFILE STEEL DECK ASSEMBLIES – 3.5" DOVETAIL DECK

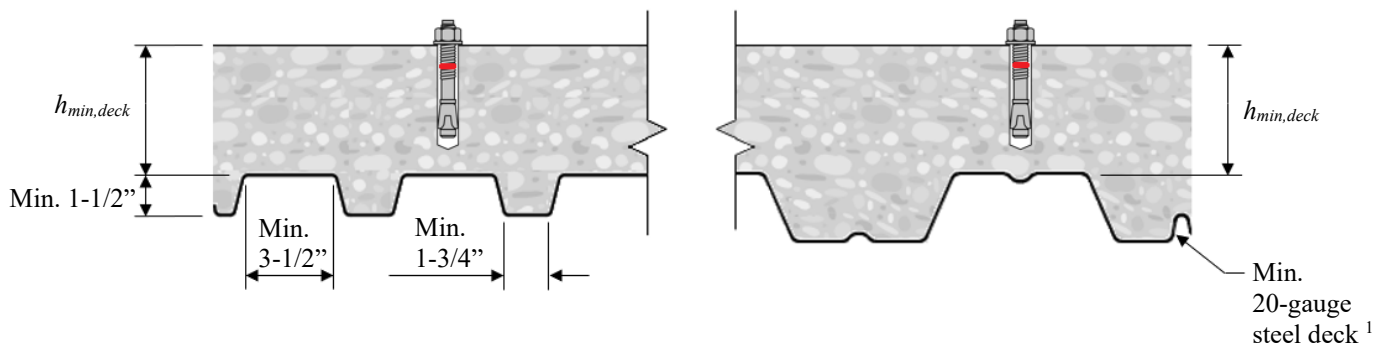

FIGURE 5F—KB-TZ2 IN THE TOP OF CONCRETE FILLED PROFILE STEEL DECK ASSEMBLIES

¹ 1 1/2 inches (38 mm) B-deck as a minimum profile size. Other deck profiles meeting the B-deck minimum dimensions are also permitted.

TABLE 10— APPLICABLE SECTIONS OF THE IBC UNDER EACH EDITION OF THE IBC

2024 IBC	2021 IBC	2018 IBC	2015 IBC
Section 1605.1		Section 1605.2 or 1605.3	
Section 1705.1.1 and Table 1705.3			
Section 1901.3			
Sections 1903 and 1905			
Section 1905.7	Section 1905.1.8		

TABLE 11— APPLICABLE SECTIONS OF ACI 318 UNDER EACH EDITION OF THE IBC

2024 IBC	2021 IBC	2018 IBC	2015 IBC
ACI 318-19		ACI 318-14	
2.3			2.3
5.3			5.3
Chapter 17		Chapter 17	
17.2.4			17.2.6
17.3.1			17.2.7
17.5.1.2			17.3.1
17.5.1.3			17.3.1.1
17.5.3			17.3.3
17.6.1			17.4.1
17.6.1.2			17.4.1.2
17.6.2			17.4.2
17.6.2.1			17.4.2.1
17.6.2.2			17.4.2.2
17.6.2.5.1(a)			17.4.2.6
17.6.3			17.4.3
17.6.3.1			17.4.3.1
17.6.3.2.1			17.4.3.2
17.6.3.3			17.4.3.6
17.7.1			17.5.1
17.7.1.2			17.5.1.2
Eq. 17.7.1.2b			Eq. 17.5.1.2b
17.7.2			17.5.2
17.7.2.2.1			17.5.2.2
17.7.3			17.5.3
17.8			17.6
17.9.2			17.7.1 and 17.7.3
17.9.4			17.7.5
17.9.5			17.7.6
17.10			17.2.3
17.10.3			17.2.3.3
17.10.4, 17.10.5, 17.10.6, 17.10.7			17.2.3.4, 17.2.3.5, 17.2.3.6, 17.2.3.7

Hilti SafeSet™ System with Hollow Drill Bit	Hilti SafeSet™ System with the Adaptive Torque Tool	Hilti Dust Removal Systems	Core Drill Systems
 <p>Hilti TE-CD or TE-YD Hollow Carbide Drill Bit, with</p>  <p>Hilti Vacuum (per section 4.3)</p>	 <p>Hilti SIW-6AT-A22/SIW-4AT-22/SIW-6AT-22 Impact Wrench, with</p>  <p>Hilti SI-AT-A22/SI-AT-22 Adaptive Torque Module</p>	 <p>Hilti Rotary Hammer Drill with DRS (Dust Removal System) Module, or</p>  <p>Hilti TE DRS-D Dust Removal System with Hilti Vacuum</p>	 <p>Handheld Hilti DD 30 Core Drill, with</p>  <p>SPX-T Hilti Core Bits (per Section 4.3)</p>

FIGURE 6—HILTI SYSTEM COMPONENTS

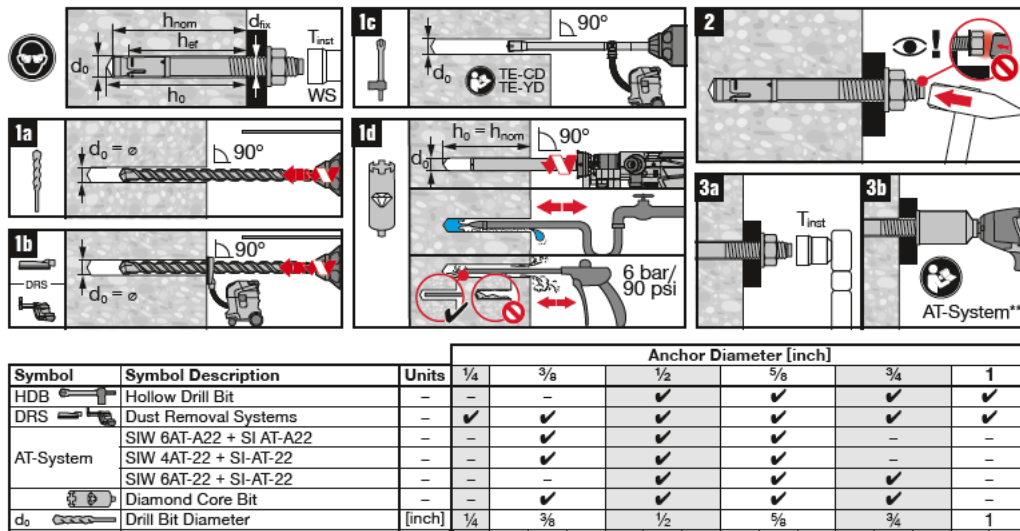

FIGURE 7—INSTALLATION INSTRUCTIONS

This report remains under an active [continuous compliance program](#) through the end of December 2027.

www.icc-es.org | (800) 423-6587 | (562) 699-0543

A Subsidiary of the International Code Council®

DIVISION: 03 00 00—CONCRETE
Section: 03 16 00—Concrete Anchors

DIVISION: 05 00 00—METALS
Section: 05 05 19—Post-Installed Concrete Anchors

REPORT HOLDER:

HILTI, INC.

EVALUATION SUBJECT:

HILTI KWIK BOLT TZ2 CARBON AND STAINLESS STEEL ANCHORS IN CRACKED AND UNCRACKED CONCRETE

1.0 REPORT PURPOSE AND SCOPE

Purpose:

The purpose of this evaluation report supplement is to indicate that the Kwik Bolt TZ2 (KB-TZ2) carbon and stainless steel anchors in cracked and uncracked concrete, described in ICC-ES evaluation report [ESR-4266](#), have also been evaluated for compliance with the codes noted below as adopted by the Los Angeles Department of Building and Safety (LADBS).

Applicable code editions:

- 2023 City of Los Angeles Building Code ([LABC](#))
- 2023 City of Los Angeles Residential Code ([LARC](#))

2.0 CONCLUSIONS

The Kwik Bolt TZ2 (KB-TZ2) carbon and stainless steel anchors in cracked and uncracked concrete, described in Sections 2.0 through 7.0 of the evaluation report [ESR-4266](#), comply with LABC Chapter 19, and the LARC, and are subject to the conditions of use described in this supplement.

3.0 CONDITIONS OF USE

The Kwik Bolt TZ2 (KB-TZ2) carbon and stainless steel anchors in cracked and uncracked concrete described in this evaluation report supplement must comply with all of the following conditions:

- All applicable sections in the evaluation report [ESR-4266](#).
- The design, installation, conditions of use and identification of the Kwik Bolt TZ2 (KB-TZ2) anchors are in accordance with the 2021 *International Building Code*® (IBC) provisions noted in the evaluation report [ESR-4266](#).
- The design, installation and inspection are in accordance with additional requirements of LABC Chapters 16 and 17, and City of Los Angeles Information Bulletin P/BC 2020-092, as applicable.
- Under the LARC, an engineered design in accordance with LARC Section R301.1.3 must be submitted.
- The allowable and strength design values listed in the evaluation report and tables are for the connection of the anchors to concrete. The connection between the anchors and the connected members shall be checked for capacity (which may govern).
- For use in wall anchorage assemblies to flexible diaphragm applications, anchors shall be designed per the requirements of City of Los Angeles Information Bulletin P/BC 2023-071.

This supplement expires concurrently with the evaluation report, reissued December 2025 and revised June 2026.

DIVISION: 03 00 00—CONCRETE

Section: 03 16 00—Concrete Anchors

DIVISION: 05 00 00—METALS

Section: 05 05 19—Post-Installed Concrete Anchors

REPORT HOLDER:

HILTI, INC.

EVALUATION SUBJECT:

HILTI KWIK BOLT TZ2 CARBON AND STAINLESS STEEL ANCHORS IN CRACKED AND UNCRACKED CONCRETE

1.0 REPORT PURPOSE AND SCOPE

Purpose:

The purpose of this evaluation report supplement is to indicate that the Kwik Bolt TZ2 (KB-TZ2) carbon and stainless steel anchors in cracked and uncracked concrete, described in ICC-ES evaluation report [ESR-4266](#), have also been evaluated for compliance with the codes noted below.

Applicable code editions:

- 2023 Florida Building Code—Building
- 2023 Florida Building Code—Residential

2.0 CONCLUSIONS

The Kwik Bolt TZ2 (KB-TZ2) carbon and stainless steel anchors in cracked and uncracked concrete, described in Sections 2.0 through 7.0 of the evaluation report [ESR-4266](#), comply with the *Florida Building Code—Building* and the *Florida Building Code—Residential*, provided the design requirements are determined in accordance with the *Florida Building Code—Building* or the *Florida Building Code—Residential*, as applicable. The installation requirements noted in the ICC-ES evaluation report [ESR-4266](#) for the 2021 *International Building Code*® meet the requirements of the *Florida Building Code—Building* or the *Florida Building Code—Residential*, as applicable.

Use of the Kwik Bolt TZ2 (KB-TZ2) carbon and stainless steel anchors in cracked and uncracked concrete have also been found to be in compliance with the High-Velocity Hurricane Zone provisions of the *Florida Building Code—Building* and the *Florida Building Code—Residential*, with the following conditions:

- For anchorage of wood members, the connection subject to uplift must be designed for no less than 700 pounds (3114 N).
- For connection to aluminum members, all expansion anchors must be installed no less than 3 inches from the edge of concrete slab and/or footings. All expansion anchors shall develop an ultimate withdrawal resisting force equal to four times the imposed load, with no stress increase for duration of load.

For products falling under Florida Rule 61G20-3, verification that the report holder's quality assurance program is audited by a quality assurance entity approved by the Florida Building Commission for the type of inspections being conducted is the responsibility of an approved validation entity (or the code official, when the report holder does not possess an approval by the Commission). Florida Rule 61G20-3 is applicable to products and/or systems which comprise the building envelope and structural frame for compliance with the structural requirements of the Florida Building Code.

This supplement expires concurrently with the evaluation report, reissued December 2025 and revised June 2026.