

ICC-ES Evaluation Report

ESR-3693

Reissued May 2025

This report also contains:

- [City of LA Supplement](#)

Subject to renewal May 2027

- [FL Supplement w/HVHZ](#)

ICC-ES Evaluation Reports are not to be construed as representing aesthetics or any other attributes not specifically addressed, nor are they to be construed as an endorsement of the subject of the report or a recommendation for its use. There is no warranty by ICC Evaluation Service, LLC, express or implied, as to any finding or other matter in this report, or as to any product covered by the report.

Copyright © 2025 ICC Evaluation Service, LLC. All rights reserved.

<p>DIVISION: 05 00 00—METALS</p> <p>Section: 05 05 23—Metal Fastenings</p> <p>Section: 05 31 00—Steel Decking</p>	<p>REPORT HOLDER:</p> <p>HILTI, INC.</p>	<p>EVALUATION SUBJECT:</p> <p>STEEL DECK DIAPHRAGMS ATTACHED WITH HILTI S-MD 12-24 x 1⁵/₈ M OR S-RT5+ M9 FRAME FASTENERS AND HILTI S-SLC 01 M HWH, S-SLC 02 M HWH, OR S-MD 10-16 x 3⁴/₄ M HWH3, S-MD 10-16 x 3⁴/₄ HWH3 M9, S-MD 12-24 x 7⁸/₈ M HWH4, AND S-MD 12-24 x 7⁸/₈ HWH4 M9 SCREW SIDELAP CONNECTORS, VERCO VSC2 SIDELAP CONNECTIONS, OR BUTTON PUNCH SIDELAP CONNECTIONS</p>	
--	--	--	---

1.0 EVALUATION SCOPE

Compliance with the following codes:

- 2021, 2018 and 2015 [International Building Code® \(IBC\)](#)

Property evaluated:

Structural

2.0 USES

Hilti's S-MD 12-24 x 1⁵/₈ M and S-RT5+ M9 frame fasteners are used to attach B, BI, and Verco PLB steel roof deck panels to supporting steel framing. Hilti's S-SLC 01 M HWH, S-SLC 02 M HWH, S-MD 10-16 x 3⁴/₄ M HWH3, S-MD 10-16 x 3⁴/₄ HWH3 M9, S-MD 12-24 x 7⁸/₈ M HWH4, and S-MD 12-24 x 7⁸/₈ HWH4 M9 screws, Verco's VSC2 sidelap connections, and button punch sidelap connections are used to connect the steel deck panels together at the panel sidelaps.

3.0 DESCRIPTION

3.1 Frame Fasteners:

The Hilti S-MD 12-24 x 1⁵/₈ M self-drilling screw fasteners are case-hardened from carbon steel conforming to ASTM A510, Grade 1018 to 1022 with an electroplated zinc coating conforming to ASTM B633-13, SC 1,

Type III. The fasteners also comply with ASTM C1513 and SAE J78 and have Hex Washer head styles. The fasteners are nominally 1.625-inch (41.3 mm) long and have a nominal 0.216-inch (5.5 mm) diameter with 24 threads per inch.

The Hilti S-RT5+ M9 self-drilling screw fasteners are case-hardened from carbon steel conforming to ASTM A510, Grade 1022 with a Zn-Ni coating. The fasteners are nominally 1.339-inch (34.0 mm) long and have a nominal 0.228-inch (5.8 mm) diameter with 24 threads per inch.

[Table 1](#) provides an illustration and additional information on the fasteners. The fasteners are collated for use in a tool recommended by Hilti.

3.2 Steel Deck Panels:

Steel deck panels must be No. 16, 18, 20 or 22 gage Type B (nestable), Type BI (interlocking), or Vercos PLB (interlocking) complying with [Figure 4](#).

The B and BI steel deck panels must conform to the requirements of ASTM A653 SS, Grade 33 (minimum) with minimum G60 galvanized coating or must be painted or phosphatized steel complying with ASTM A1008-12 SS, Grade 33 (minimum).

The B and BI steel deck panels must be 36 inches (914 mm) in width with 1¹/₂-inch-deep (38 mm) flutes spaced 6 inches (152 mm) on center. The B steel deck panels must have nestable sidelaps and the BI steel deck panels must have interlocking (standing seam) sidelaps.

The Vercos PLB steel deck panels must comply with ASTM A653 SS Grade 50 Classes 1, 3, or 4 (minimum) steel, with a minimum G30 galvanized coating designation, or be phosphatized/painted, painted/painted, or mill-finished steel complying with ASTM A1008 SS Grade 50 (minimum).

3.3 Sidelap Connectors/Connections:

The steel deck panel sidelap connections must be made with either Hilti S-SLC 01, S-SLC 02 S-MD 10-16 x ³/₄ M HWH3, S-MD 10-16 x ³/₄ HWH3 M9, S-MD 12-24 x ⁷/₈ M HWH4, or S-MD 12-24 x ⁷/₈ HWH4 M9 screws; button punches as described in Section 4.1; or Vercos VSC2 sidelap connections as described in [ESR-2776](#). [Table 2](#) provides illustrations and additional information on the sidelap connectors.

3.4 Steel Support Framing:

Structural steel supports of the steel deck panels (such as gage purlin, bar joists, and structural steel shapes) must be manufactured from a code-compliant steel having minimum strength requirements of ASTM A653 (minimum yield strength of 33 ksi and minimum tensile strength of 45 ksi) for gage purlins or ASTM A36 for bar joists and structural steel shapes and minimum thicknesses as noted in the tables of this report.

4.0 DESIGN AND INSTALLATION

4.1 Installation:

4.1.1 General: The B and BI steel deck panels must be attached to steel support framing with the Hilti S-MD 12-24 x 1⁵/₈ M or S-RT5+ frame fasteners in accordance with [Table 1](#) and the steel deck panel sidelaps must be attached with Hilti S-SLC 01 or S-SLC 02 screws, S-MD 10-16 x ³/₄ M HWH3, S-MD 10-16 x ³/₄ HWH3 M9, S-MD 12-24 x ⁷/₈ M HWH4, or S-MD 12-24 x ⁷/₈ HWH4 M9 screws, button punches.

The Vercos PLB deck is fastened to the structural supports with the Hilti S-MD 12-24 x 1⁵/₈ M or S-RT5+ M9 frame fasteners in accordance with [Table 1](#) and the sidelaps are connected with Vercos's VSC2 Connection in accordance with [Table 2](#).

The Hilti fasteners must be installed in accordance with Hilti's published installation instructions and the Vercos VSC2 sidelap connections must be installed in accordance with Vercos's published installation instructions.

Steel deck panel ends must overlap a minimum of 2 inches (51 mm), as shown in [Figure 3b](#). Endlap and corner lap conditions of two- and four-deck layers must be snug and tight to one another and the supporting steel frame, prior to frame fastener attachment. Standing seam interlocking-type sidelaps must be well engaged prior to sidelap connector installation.

Frame fasteners must be installed in the specified pattern, and sidelap connectors must be installed at the specified spacing (see [Figure 2a](#)) or number of connectors per span (see [Figure 2b](#)). The frame fastener patterns are shown in [Figure 1](#). [Figure 3](#) shows typical frame fastener and sidelap connector connection details.

Button-punching must be sharp and deep. The coating of the outer protruding nose of the punched lap should be “starred,” indicating a near-penetration of the button punching tool.

4.1.2 Frame Fasteners: The Hilti S-MD 12-24 x 1⁵/₈ M and S-RT5+ M9 frame fasteners:

- must be centered not less than ³/₈ inch (9.5 mm) from the steel deck panel ends and not less than ⁵/₁₆ inch (7.9 mm) from the steel deck panel edges parallel to corrugations at the sidelaps;
- must penetrate through the supporting steel with a minimum of three threads protruding past the back side of the supporting steel.

The number of diaphragm edge frame fasteners at walls or transfer zones parallel to the deck corrugations must be equal to or greater than the number of sidelap connectors at nearest interior sidelaps.

See [Table 1](#) for applicable steel support framing thicknesses; [Figure 1](#) for frame fastener patterns; and [Figures 3a](#) and [3b](#) for frame fastener installation details.

4.1.3 Sidelap Connectors: The Hilti S-SLC 01 and Hilti S-SLC 02 screws, S-MD 10-16 x ³/₄ M HWH3, S-MD 10-16 x ³/₄ HWH3 M9, S-MD 12-24 x ⁷/₈ M HWH4, and S-MD 12-24 x ⁷/₈ HWH4 M9 screws, button punches, and Verco’s VSC2 sidelap connections:

- must penetrate through the steel deck panel not in contact with the sidelap connector or screw head with a minimum of three threads protruding (only applicable to sidelap screws);
- must not exceed 36 inches (914.4 mm) on center.

See [Table 2](#) for applicable steel deck panel thicknesses; and [Figures 3c](#), [3d](#), and [3e](#) for sidelap connection details.

4.2 Design:

For symbols and definitions, see the American Iron and Steel Institute’s North American Standard for the Design of Profiled Steel Diaphragm Panels (AISI S310-20 w/S1-22).

4.2.1 Diaphragm Shear and Stiffness by Calculations:

The allowable (ASD) or factored (LRFD) diaphragm shear strength and stiffness must be determined in accordance with AISI S310-20 w/S1-22 while using [Tables 3](#), [4](#), [5](#), and [6](#). The diaphragm shear strength must also be multiplied by the correlation factors in [Table 4](#). The allowable (ASD) or factored (LRFD) diaphragm shear strength must not be greater than the allowable (ASD) or factored (LRFD) diaphragm buckling strengths in [Table 7](#).

Minimum sidelap spacing of fasteners noted in [Table 11](#) must be considered.

An example calculation can be found at the end of this report.

4.2.2 Diaphragm Deflections: For the 2015 IBC and earlier codes, diaphragm deflection (Δ) must be calculated in accordance with the footnotes of [Table 10](#). For seismic design, diaphragm deflection limits must comply with ASCE 7/SEI Chapter 12.

4.2.3 Uplift/Tension: For designs considering uplift/tension forces, see [Tables 8](#) and [9](#).

5.0 CONDITIONS OF USE:

The steel deck diaphragms attached with Hilti S-MD 12-24 x 1⁵/₈ M or S-RT5+ M9 frame fasteners and the sidelap connectors described in this report comply with, or are a suitable alternative to what is specified in, those codes listed in Section 1.0 of this report, subject to the following conditions:

- 5.1** The fasteners are manufactured, identified, and installed in accordance with this report, Hilti’s published installation instructions and the approved plans. If there is a conflict, this report governs.
- 5.2** Steel deck panels must comply with this report. When the steel deck panels are used as roof decks, the panel must be covered with an approved code-complying roof covering.
- 5.3** No adjustment for duration of load is permitted.
- 5.4** Steel deck diaphragms may be zoned by varying steel deck panel gage and/or connections across a diaphragm to meet varying shear and flexibility demands.
- 5.5** For intermediate steel deck panel thicknesses or panel steel strengths, diaphragm strength and stiffness values shall be based on straight-line interpolation between values determined in accordance with Section 4.2.

- 5.6 The design of the steel deck panels for vertical loads is outside the scope of this report.
- 5.7 Calculations demonstrating compliance with this report must be submitted to the code official for approval. The calculations must be prepared by a registered design professional where required by the statutes of the jurisdiction in which the project is to be constructed.
- 5.8 Hilti fasteners may be used for attachment of steel deck roof systems temporarily exposed to the exterior during construction prior to application of built-up roof covering systems. The fasteners on permanently exposed steel deck roof coverings must be covered with a corrosion-resistant paint or sealant. For permanently exposed steel deck roof covering installations, the roof covering system's compliance with Chapter 15 of the IBC must be justified to the satisfaction of the code official.

6.0 EVIDENCE SUBMITTED



- 6.1 Data in accordance with the [ICC-ES Acceptance Criteria for Steel Deck Roof and Floor Systems \(AC43\)](#), dated August 2022.
- 6.2 Data in accordance with the [ICC-ES Acceptance Criteria for Tapping Screw Fasteners Used in Steel-to-Steel Connections \(AC118\)](#), dated January 2018 (editorially revised December 2020).

7.0 IDENTIFICATION

- 7.1 The ICC-ES mark of conformity, electronic labeling, or the evaluation report number (ICC-ES ESR-3693) along with the name, registered trademark, or registered logo of the report holder must be included in the product label. [Electronic labeling is the ICC-ES web address (www.icc-es.org); specific URL related to the report; or the ICC-ES machine-readable code placed on the aforementioned items.]
- 7.2 In addition, the S-MD 12-24 x 1⁵/₈ M, S-RT5+ M9, S-SLC 01 M HWH, S-SLC 02 M HWH, S-MD 10-16 x 3/4 M HWH3, S-MD 10-16 x 3/4 HWH3 M9, S-MD 12-24 x 7/8 M HWH4, and S-MD 12-24 x 7/8 HWH4 M9 fasteners are identified by an "H" stamped on the fastener head. All fasteners are packaged in containers noting the fastener type.
- 7.3 The report holder's contact information is the following:

HILTI, INC.
7250 DALLAS PARKWAY, SUITE 1000
PLANO, TEXAS 75024
(800) 879-8000
www.hilti.com

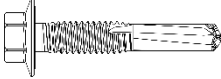

TABLE 1—FRAME FASTENER SELECTOR GUIDE¹

Steel Support Framing Thickness (t_f)	Fastener Type
$\frac{1}{8}$ in. $\leq t_f \leq \frac{3}{8}$ in.	 S-RT5+ M9
0.0598 in. $\leq t_f \leq \frac{1}{4}$ in.	 S-MD 12-24 x 1 ⁵ / ₈ M

For SI: 1 inch = 2.54 mm

¹Steel support framing must comply with the minimum strength requirements of ASTM A653 for gage purlins or ASTM A36 for bar joists and structural steel shapes as indicated in Section 3.4.

TABLE 2—SIDELAP CONNECTOR SELECTOR GUIDE

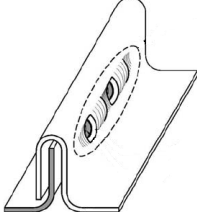
Steel Deck Panel Thicknesses	Fastener Type
No's. 22, 20, 18 gage B and BI decks ¹	 Hilti S-SLC 01 M HWH
No's. 22, 20, 18, 16 gage B and BI decks ¹	 Hilti S-SLC 02 M HWH
No's. 22, 20, 18, 16 gage B and BI decks ¹	 Hilti No. 10 HWH Screw
No's. 22, 20, 18, 16 gage BI decks	Button Punch (As described in this report)
No's. 22, 20, 18, 16 gage Verco PLB Deck decks	 Verco's VSC 2 Connection

¹These sidelap connectors require BI deck to be screwable.

TABLE 3—DIAPHRAGM STRENGTH (S) AND DIAPHRAGM STIFFNESS (G') EQUATION VARIABLE VALUES
(to be used with equations in AISI S310, Sections D1, D2 and D5.1)

DECK TYPE ¹	FRAME FASTENER PATTERN ²	α_1 or α_3 — END DISTRIBUTION FACTOR	α_2 or α_4 — PURLIN DISTRIBUTION FACTOR	Σx_{e2}^2 or Σx_{e1}^2 , in. ²	Σx_{p2}^2 or Σx_{p1}^2 , in. ²	s/d	A	N per ft.	D _n – WARPING FACTOR, IN.			
									No. 22 (0.0295)	No. 20 (0.0358)	No. 18 (0.0474)	No. 16 (0.0598)
B	36/11	3.667	3.667	1,944	1,944	1.365	2	3.000	1,235	924	606	428
	36/9	3.000	3.000	1,656	1,656	1.365	2	2.333	1,235	924	606	428
	36/7	2.000	2.000	1,008	1,008	1.365	1	2.000	1,235	924	606	428
	36/5	1.667	1.667	936	936	1.365	1	1.333	7,288	5,452	3,578	2,525
	36/4	1.333	1.333	720	720	1.365	1	1.000	10,315	7,715	5,064	3,574
	36/3	1.000	1.000	648	648	1.365	1	0.667	21,217	15,871	10,417	7,315
Bl or Vercor PLB	36/11	3.667	3.667	1,944	1,944	1.365	2	3.667	1,235	924	606	428
	36/9	3.000	3.000	1,656	1,656	1.365	2	3.000	1,235	924	606	428
	36/7	2.000	2.000	1,008	1,008	1.365	1	2.333	1,235	924	606	428

For SI: 1inch = 25.4 mm, 1 in.² = 645 mm², 1 ft⁻¹ = 3.28m⁻¹.

¹See Figure 4 for applicable steel deck panels.

²See Figure 1 for frame fastener patterns.

TABLE 4—DIAPHRAGM STRENGTH EQUATION VARIABLE VALUES

CONFIGURATION				STEEL DECK PANEL GAGE THICKNESS							
				No. 22		No. 20		No. 18		No. 16	
Deck Type ¹	Minimum Deck Tensile, F _u , (Yield, F _y) Strengths, ksi	Frame Fastener & Steel Support Framing Thickness (t _f), in.	Sidelap Connector ²	Pnf (lbf)	Pns (lbf)	Pnf (lbf)	Pns (lbf)	Pnf (lbf)	Pns (lbf)	Pnf (lbf)	Pns (lbf)
				Correlation Factor, c		Correlation Factor, c		Correlation Factor, c		Correlation Factor, c	
B	65 (50)	S-RT5+ M9 1/8 ≤ t _f < 3/16	S-SLC 01 M HWH S-SLC 02 M HWH	1,357	844	1,824	1,260	1,865	1,701	-	-
				1.184 ⁴		1.201 ⁴		1.233 ⁴		-	
		S-RT5+ M9 3/16 ≤ t _f ≤ 3/8	S-SLC 01 M HWH S-SLC 02 M HWH	1,590	844	2,107	1,260	2,663	1,701	3,035	2,024
				1.149 ⁴		1.127 ⁴		1.087 ⁴		1.044 ⁴	
		S-RT5+ M9 1/8 ≤ t _f < 3/16	No. 10 or 12 screws ³	1,489	598 ⁵	1,795	799 ⁵	2,348	1,217 ⁵	-	-
				1.000		1.000		1.000		-	
		S-RT5+ M9 3/16 ≤ t _f ≤ 3/8	No. 10 or 12 screws ³	1,489	598 ⁵	1,795	799 ⁵	2,348	1,217 ⁵	2,924	1,725 ⁵
				1.000		1.000		1.000		1.000	
		S-MD 12-24 x 1 ⁵ / ₈ M 0.0598 ≤ t _f < 1/8	S-SLC 01 M HWH S-SLC 02 M HWH	1,016	844	1,233	1,260	1,632	1,701	1,860	2,024
				1.000		1.000		1.000		1.000	
		S-MD 12-24 x 1 ⁵ / ₈ M 1/8 ≤ t _f ≤ 1/4	S-SLC 01 M HWH S-SLC 02 M HWH	1,193	844	1,661	1,260	1,860	1,701	1,860	2,024
				1.000		1.000		1.000		1.000	
		S-MD 12-24 x 1 ⁵ / ₈ M 0.0598 ≤ t _f < 1/8	No. 10 or 12 screws ³	1,016	598 ⁵	1,233	799 ⁵	1,632	1,217 ⁵	1,860	1,725 ⁵
				1.000		1.000		1.000		1.000	
S-MD 12-24 x 1 ⁵ / ₈ M 1/8 ≤ t _f ≤ 1/4	No. 10 or 12 screws ³	1,193	598 ⁵	1,661	799 ⁵	1,860	1,217 ⁵	1,860	1,725 ⁵		
		1.000		1.000		1.000		1.000			

For SI: 1 inch = 25.4 mm, 1 lbf = 4.45 N, 1 ksi = 6.89 MPa.

¹See Figure 4 for steel deck panel thicknesses in inches [(mils), (mm)].

²For steel deck panel thicknesses applicable to the specific panel sidelap connector, see Table 2.

³Screws must be Hilti S-MD 10-16 x 3/4 M HWH3, S-MD 10-16 x 3/4 HWH3 M9, S-MD 12- M HWH4, or S-MD 12- HWH4 M9.

⁴For steel deck with minimum deck strength of 55 (40) Tensile, F_u, (Yield, F_y) ksi, the corresponding correlation factors (c) must be calculated by applying a reduction factor of 0.989. For steel deck with minimum deck strength of 45 (33) Tensile, F_u, (Yield, F_y) ksi; the corresponding correlation factors (c) must be calculated by applying a reduction factor of 0.976.

⁵For steel deck with minimum deck strength of 55 (40) Tensile, F_u, (Yield, F_y) ksi, the corresponding sidelap connector strength must be calculated by applying a reduction factor of 0.85. For steel deck with minimum deck strength of 45 (33) Tensile, F_u, (Yield, F_y) ksi, the corresponding sidelap connector strength must be calculated by applying a reduction factor of 0.69.

TABLE 4—DIAPHRAGM STRENGTH EQUATION VARIABLE VALUES (Continued)

CONFIGURATION				STEEL DECK PANEL GAGE THICKNESS							
				No. 22		No. 20		No. 18		No. 16	
Deck Type ¹	Minimum Deck Tensile, F _u , (Yield, F _y) Strengths, ksi	Frame Fastener & Steel Support Framing Thickness (t _f), in.	Sidelap Connector ²	P _{nf} (lbf)	P _{ns} (lbf)	P _{nf} (lbf)	P _{ns} (lbf)	P _{nf} (lbf)	P _{ns} (lbf)	P _{nf} (lbf)	P _{ns} (lbf)
				Correlation Factor, c		Correlation Factor, c		Correlation Factor, c		Correlation Factor, c	
BI	65 (50)	S-RT5+ M9 $\frac{1}{8} \leq t_f < \frac{3}{16}$	S-SLC 01 M HWH S-SLC 02 M HWH	1,357	844	1,712	1,111	1,865	1,591	-	-
				1.184 ⁴		1.201 ⁴		1.233 ⁴		-	
		S-RT5+ M9 $\frac{3}{16} \leq t_f \leq \frac{3}{8}$	S-SLC 01 M HWH S-SLC 02 M HWH	1,516	882	1,712	1,111	2,450	1,591	2,553	2,051
				1.316 ⁴		1.264 ⁴		1.168 ⁴		1.066 ⁴	
		S-RT5+ M9 $\frac{1}{8} \leq t_f < \frac{3}{16}$	No. 10 or 12 screws ³	1,489	598 ⁵	1,795	799 ⁵	2,348	1,217 ⁵	-	-
				1.000		1.000		1.000		-	
		S-RT5+ M9 $\frac{3}{16} \leq t_f \leq \frac{3}{8}$	No. 10 or 12 screws ³	1,489	598 ⁵	1,795	799 ⁵	2,348	1,217 ⁵	2,924	1,725 ⁵
				1.000		1.000		1.000		1.000	
		S-RT5+ M9 $\frac{1}{8} \leq t_f < \frac{3}{16}$	Button Punch	1,489	209	1,795	308	2,348	539	-	-
				1.000		1.000		1.000		-	
		S-RT5+ M9 $\frac{3}{16} \leq t_f \leq \frac{3}{8}$	Button Punch	1,489	209	1,795	308	2,348	539	2,924	858
				1.000		1.000		1.000		1.000	
		S-MD 12-24 x 1 ⁵ / ₈ M 0.0598 ≤ t _f < 1/8	S-SLC 01 M HWH S-SLC 02 M HWH	1,016	844	1,233	1,260	1,632	1,701	1,860	2,024
				1.000		1.000		1.000		1.000	
S-MD 12-24 x 1 ⁵ / ₈ M 1/8 ≤ t _f ≤ 1/4	S-SLC 01 M HWH S-SLC 02 M HWH	1,193	844	1,661	1,260	1,860	1,701	1,860	2,024		
		1.000		1.000		1.000		1.000			
S-MD 12-24 x 1 ⁵ / ₈ M 0.0598 ≤ t _f < 1/8	No. 10 or 12 screws ³	1,016	598 ⁵	1,233	799 ⁵	1,632	1,217 ⁵	1,860	1,725 ⁵		
		1.000		1.000		1.000		1.000			
S-MD 12-24 x 1 ⁵ / ₈ M 1/8 ≤ t _f ≤ 1/4	No. 10 or 12 screws ³	1,193	598 ⁵	1,661	799 ⁵	1,860	1,217 ⁵	1,860	1,725 ⁵		
		1.000		1.000		1.000		1.000			
S-MD 12-24 x 1 ⁵ / ₈ M 0.0598 ≤ t _f < 1/8	Button Punch	1,016	209	1,233	308	1,632	539	1,860	858		
		1.000		1.000		1.000		1.000			
S-MD 12-24 x 1 ⁵ / ₈ M 1/8 ≤ t _f ≤ 1/4	Button Punch	1,193	209	1,661	308	1,860	539	1,860	858		
		1.000		1.000		1.000		1.000			
Verco PLB	65 (50)	S-RT5+ M9 $\frac{1}{8} \leq t_f < \frac{3}{16}$	Verco VSC2	1,357	2,067	1,712	2,823	1,865	4,323	1,865	4,323
				1.000		1.000		1.000		1.000	
		S-RT5+ M9 $\frac{3}{16} \leq t_f \leq \frac{3}{8}$	Verco VSC2	1,489	2,067	1,795	2,823	2,348	4,323	2,924	5,835
				1.000		1.000		1.000		1.000	
		S-MD 12-24 x 1 ⁵ / ₈ M 0.0598 ≤ t _f < 1/8	Verco VSC2	1,016	2,067	1,233	2,823	1,632	4,323	1,860	5,835
				1.000		1.000		1.000		1.000	
		S-MD 12-24 x 1 ⁵ / ₈ M 1/8 ≤ t _f ≤ 1/4	Verco VSC2	1,193	2,067	1,661	2,823	1,860	4,323	1,860	5,835
				1.000		1.000		1.000		1.000	

For SI: 1 inch = 25.4 mm, 1 lbf = 4.45 N, 1 ksi = 6.89 MPa.

¹See Figure 4 for steel deck panel thicknesses in inches [(mils), (mm)].

²For steel deck panel thicknesses applicable to the specific panel sidelap connector, see Table 2.

³Screws must be Hilti S-MD 10-16 x 3/4 M HWH3, S-MD 10-16 x 3/4 HWH3 M9, S-MD 12-24 x 7/8 M HWH4, or S-MD 12-24 x 7/8 HWH4 M9.

⁴For steel deck with minimum deck strength of 55 (40) Tensile, F_u, (Yield, F_y) ksi, the corresponding correlation factors (c) must be calculated by applying a reduction factor of 0.989. For steel deck with minimum deck strength of 45 (33) Tensile, F_u, (Yield, F_y) ksi; the corresponding correlation factors (c) must be calculated by applying a reduction factor of 0.976.

⁵For steel minimum deck strength of 55 (40) Tensile, F_u, (Yield, F_y) ksi, the corresponding sidelap connector strength must be calculated by applying deck with a reduction factor of 0.85. For steel deck with minimum deck strength of 45 (33) Tensile, F_u, (Yield, F_y) ksi, the corresponding sidelap connector strength must be calculated by applying a reduction factor of 0.69.

TABLE 5—DIAPHRAGM STIFFNESS (G') EQUATION VARIABLE VALUES⁴

CONFIGURATION				STEEL DECK PANEL GAGE THICKNESS ¹			
				No. 22 gage	No. 20 gage	No. 18 gage	No. 16 gage
Deck Type	Minimum Deck Tensile, F _u , (Yield, F _y) Strengths, ksi	Frame Fastener	Sidelap Connector ²	Sf, in./kip	Sf, in./kip	Sf, in./kip	Sf, in./kip
				Ss, in./kip	Ss, in./kip	Ss, in./kip	Ss, in./kip
B or BI	45 (33)	S-RT5+ M9	S-SLC 01 M HWH S-SLC 02 M HWH No. 10 or 12 screws ³	0.0073	0.0066	0.0057	0.0051
				0.0175	0.0159	0.0138	0.0123
	45 (33)	S-MD 12-24 x 1 ⁵ / ₈ M	S-SLC 01 M HWH S-SLC 02 M HWH No. 10 or 12 screws ³	0.0076	0.0069	0.0060	0.0053
				0.0175	0.0159	0.0138	0.0123
BI	45 (33)	S-RT5+ M9	Button Punch	0.0073	0.0066	0.0057	0.0051
				0.1747	0.1586	0.1378	0.1227
		S-MD 12-24 x 1 ⁵ / ₈ M	Button Punch	0.0076	0.0069	0.0060	0.0053
				0.1747	0.1586	0.1378	0.1227
Verco PLB	65 (50)	S-RT5+ M9	Verco VSC2	0.0073	0.0066	0.0057	0.0051
				0.0360	0.0253	0.0115	0.0074
		S-MD 12-24 x 1 ⁵ / ₈ M	Verco VSC2	0.0076	0.0069	0.0060	0.0053
				0.0360	0.0253	0.0115	0.0074

For SI: 1 inch = 25.4 mm, 1 in/kip = 5.7 mm/kN, 1 ksi = 6.89 MPa.

¹See Figure 4 for steel deck panel thicknesses in inches [(mils), (mm)].

²For steel deck panel thicknesses applicable to the specific panel sidelap connector, see Table 2.

³Screws must be Hilti S-MD 10-16 x 3/4 M HWH3, S-MD 10-16 x 3/4 HWH3 M9, S-MD 12-24 x 7/8 M HWH4, or S-MD 12-24 x 7/8 HWH4 M9.

⁴To be used with equations from AISI S310, Section D5.1.

TABLE 6—SAFETY FACTORS FOR ALLOWABLE STRENGTH DESIGN (ASD) AND RESISTANCE FACTORS FOR LOAD AND RESISTANCE FACTOR DESIGN (LRFD) IN ACCORDANCE WITH AISI S310¹

CONNECTION TYPE		LOAD TYPE OR COMBINATIONS INCLUDING	CONNECTION RELATED LIMIT STATE	
FRAME	SIDELAP		Ω _{df} (ASD)	Φ _{df} (LRFD)
S-RT5+ M9, S-MD 12-24 x 1 ⁵ / ₈ M	S-SLC 01 M HWH, S-SLC 02 M HWH, No. 10 or 12 screws ² Button Punch, Verco VSC2	Wind	2.00	0.800
		Earthquake and All Others	2.30	0.700

¹The available shear strength or factored shear resistance must be the lesser of the values determined using Table 6 and the tabulated values in Table 7.

²Screws must be Hilti S-MD 10-16 x 3/4 M HWH3, S-MD 10-16 x 3/4 HWH3 M9, S-MD 12-24 x 7/8 M HWH4, or S-MD 12-24 x 7/8 HWH4 M9.

TABLE 7—DIAPHRAGM SHEAR STRENGTHS (plf) FOR BUCKLING^{1,2}

DECK TYPE	STEEL DECK PANEL GAGE No.	MINIMUM MOMENT OF INERTIA ³ , I _{xg} (in ⁴ /ft)	SPAN, l _v (ft-in)										
			Any Span	4'-0"	5'-0"	6'-0"	7'-0"	8'-0"	9'-0"	10'-0"	11'-0"	12'-0"	
ASD			S _{nl} /Ω _{nl} ⁴	S _{no} /Ω _{no} where Ω _{no} = 2.00									
B, BI, and Verco PLB	22	0.173	1,661	4,360	2,790	1,938	1,424	1,090	861	698	576	484	
	20	0.210	2,350	5,829	3,731	2,591	1,903	1,457	1,151	933	771	648	
	18	0.279	3,880	8,904	5,698	3,957	2,907	2,226	1,759	1,425	1,177	989	
	16	0.353	5,872	12,644	8,092	5,620	4,129	3,161	2,498	2,023	1,672	1,405	
LRFD			φ _{nl} S _{nl} ⁵	Φ _{no} S _{no} where Φ _{no} = 0.80									
B, BI, and Verco PLB	22	0.173	2,658	6,975	4,464	3,100	2,278	1,744	1,378	1,116	922	775	
	20	0.210	3,760	9,327	5,969	4,145	3,046	2,332	1,842	1,492	1,233	1,036	
	18	0.279	6,208	14,246	9,118	6,332	4,652	3,562	2,814	2,279	1,884	1,583	
	16	0.353	9,395	20,231	12,948	8,992	6,606	5,058	3,996	3,237	2,675	2,248	

For SI: 1 inch = 25.4 mm, 1ft = 0.3048 m, 1 plf = 0.0146 N/mm, 1 in⁴/ft = 1,368 mm⁴/mm

¹Load values are based on AISI S310 Eq. D2-1 and Eq. D2-2.

²The available shear strength or factored shear resistance must be the lesser of the values determined using Table 6 and the tabulated values in Table 7.

³I_{xg} is the moment of inertia of the fully effective panel.

⁴For ASD evaluation under the 2021 IBC only: Compare allowable S_{nl} / Ω_{nl} (local web buckling) with S_{no} / Ω_{no} for any given span length and use the lower of the two. Provided design values are based on design yield stress, F_y, of 50 ksi and deck end bearing length, N_{ext}, of 3 inches. For other conditions, values must be revised.

⁵For LRFD evaluation under the 2021 IBC only: Compare factored resistance Φ_{nl} x S_{nl} (local web buckling) with Φ_{no} x S_{no} for any given span length and use the lower of the two. Provided design values are based on design yield stress, F_y, of 50 ksi and deck end bearing length, N_{ext}, of 3 inches. For other conditions, values must be revised.

TABLE 8—ALLOWABLE (ASD) TENSION PULLOUT LOADS TO RESIST TENSION (UPLIFT) LOADS FOR STEEL ROOF DECK PANELS ATTACHED WITH S-MD 12-24 X 1⁵/₈ M OR S-RT5+ M9 FASTENERS (lbf)¹

STEEL SUPPORT FRAMING	FASTENER	STEEL SUPPORT FRAMING THICKNESS, in. (GAGE)							
		0.0598 (16)	0.0747 (14)	0.1046 (12)	1/8	3/16	1/4	5/16	3/8
ASTM A36 (F _y = 36 ksi, F _u = 58 ksi)	S-RT5+ M9	-	-	-	435	635	750	750	750
	S-MD 12-24 x 1 ⁵ / ₈ M	215	265	370	505	505	505	-	-

For SI: 1 inch = 25.4 mm, 1 lbf = 4.45 N

¹Tabulated allowable (ASD) values based upon a Ω safety factor of 3.0. To obtain LRFD pullout capacities, the tabulated values must be multiplied by 1.6.

TABLE 9—ALLOWABLE (ASD) TENSION PULLOVER LOADS TO RESIST TENSION (UPLIFT) LOADS FOR STEEL ROOF DECK PANELS ATTACHED WITH S-MD 12-24 X 1⁵/₈ M OR S-RT5+ M9 FASTENERS (lbf)¹

STEEL SUPPORT FRAMING	FASTENER	STEEL DECK PANEL GAGE THICKNESS (in) ²			
		No. 22 (0.0295)	No. 20 (0.0358)	No. 18 (0.0474)	No. 16 (0.0598)
ASTM A36 (F _y = 36 ksi, F _u = 58 ksi)	S-RT5+ M9	480	560	725	865
	S-MD 12-24 x 1 ⁵ / ₈ M	275	335	445	560

For SI: 1 inch = 25.4 mm, 1 lbf = 4.45 N.

¹Tabulated allowable (ASD) values based upon a Ω safety factor of 3.0. To obtain LRFD pullout capacities, the tabulated values must be multiplied by 1.6.

TABLE 10—DIAPHRAGM FLEXIBILITY LIMITATION^{1,2,3,4,5}
 (Only applicable to 2015 IBC and earlier codes)

F	MAXIMUM SPAN IN FEET FOR MASONRY OR CONCRETE WALLS	SPAN-DEPTH LIMITATION			
		Rotation Not Considered in Diaphragm		Rotation Considered in Diaphragm	
		Masonry or Concrete Walls	Flexible Walls	Masonry or Concrete Walls	Flexible Walls
More than 150	Not used	Not used	2:1	Not used	1 ¹ / ₂ :1
70 – 150	200	2:1 or as required for deflection	3:1	Not used	2:1
10 – 70	400	2 ¹ / ₂ :1 or as required for deflection	4:1	As required for deflection	2 ¹ / ₂ :1
1 – 10	No limitation	3:1 or as required for deflection	5:1	As required for deflection	3:1
Less than 1	No limitation	As required for deflection	No limitation	As required for deflection	3 ¹ / ₂ :1

For SI: 1 inch = 25.4 mm, 1 foot = 304.8 mm, 1 plf = 14.594 N/m, 1 psi = 6894 Pa.

¹Diaphragms must be investigated regarding their flexibility and recommended span-depth limitations.

²Diaphragms supporting masonry or concrete walls must have their deflections limited to the following:

$$\Delta_{wall} = \frac{H^2 f_c}{0.01 Et} \quad \text{For SI: } \Delta_{wall} = \frac{694,000 H^2 f_c}{Et}$$

where:

- H = Unsupported height of wall in feet or millimeters.
- t = Thickness of wall in inches or millimeters.
- E = Modulus of elasticity of wall material for deflection determination in pounds per square inch or kilopascals.
- f_c = Allowable compression strength of wall material in flexure in pounds per square inch or kilopascals. For concrete f_c = 0.45 f_c. For masonry, f_c = F_b = 0.33 f_m.

³The total deflection Δ of the diaphragm may be computed from the equation: Δ = Δ_r + Δ_w.

where:

- Δ_r = Flexural deflection of the diaphragm determined in the same manner as the deflection of beams.
- Δ_w = The web deflection may be determined by the equation:

$$\Delta_w = \frac{q_{ave} L F}{10^6} \quad \text{For SI: } \Delta_w = \frac{q_{ave} L F}{175}$$

where:

- L = Distance in feet between vertical resisting element (such as shear wall) and the point to which the deflection is to be determined.
- q_{ave} = Average shear in diaphragm in pounds per foot or newtons per meter over length L.
- F = Flexibility factor: The average microinches or micrometers (μm) a diaphragm web will deflect in a span of 1 foot (m) under a shear of 1 pound per foot (N/m).

⁴When applying these limitations to cantilevered diaphragms, the allowable span depth ratio will be half that shown.

⁵Diaphragm classification (flexible or rigid) and deflection limits must comply with Section 4.2.

⁶The general deflection equation for rectangular symmetrical diaphragms only:

$$(d^2y)/(dx^2) = M / EI + q / B G'$$

For a uniformly loaded rectangular diaphragm on a simple span, the maximum deflection at the centerline of the diaphragm is:

$$\Delta = \frac{5(1728)qL^4}{384 EI} + qLF / 10^6 \quad \text{For SI: } \Delta = \frac{5(1000)^4 qL^4}{384 EI} + qLF / 10^6$$

- Δ = Diaphragm deflection, inches (mm).
- q = Wind or seismic load, kips per lineal foot (N/m)
- L = Length of diaphragm normal to load, feet (m).
- B = Width of diaphragm parallel to load, feet (m).
- E = Modulus of elasticity of supporting steel.
- I = Moment of inertia, inches⁴ (mm⁴).

Nonrectangular diaphragms, nonsymmetrical diaphragms with re-entrant corners or diaphragms subjected to torsional loadings require special design consideration.

TABLE 11—MINIMUM SIDELAP CONNECTOR SPACING (SS) FOR HILTI S-SLC 01 M HWH, S-SLC 02 M HWH, AND HILTI S-MD 10-16 x 3/4 M HWH3, S-MD 10-16 x 3/4 HWH3 M9, S-MD 12-24 x 7/8 M HWH4, OR S-MD 12-24 x 7/8 HWH4 M9 SCREW SIDELAP CONNECTORS, VERCO VSC2 SIDELAP CONNECTIONS, AND BUTTON PUNCH SIDELAP CONNECTIONS INSTALLED IN B-DECK, BI-DECK, OR VERCO PLB DECK (INCHES CENTER ON CENTER)¹

Frame Fastener/Steel Support Framing Thickness, in.	Deck Gage No.	Frame Fastener Pattern ²					
		36/3	36/4	36/5	36/7 ³	36/9 ^{3,4}	36/11 ^{3,4}
S-RT5+ M9 1/8 ≤ t _f ≤ 3/16	22	-	12	12	6	6	6
	20						
	18						
S-RT5+ M9 3/16 ≤ t _f ≤ 3/8	22	12	6	6	3	3	3
	20						
	18	-					
	16						

For **SI**: 1 inch = 25.4 mm, 1 ksi = 6.89 MPa.

¹When the specified sidelap connector spacing is less than those tabulated, the tabulated spacing shall be used in the calculation of diaphragm strength and stiffness when using the values for P_{nf}, P_{ns}, and c from [Table 4](#). As an alternate, when the specified sidelap connector spacing is less than those tabulated, but not less than 3 inches, the following values for P_{nf}, P_{ns}, and c may replace the values from [Table 4](#).

S-RT5+ M9 – All deck types, strengths, and steel support framing thicknesses listed in [Table 4](#)

- No. 22 Gage (0.0295 in.) – P_{nf} = 1,489 lbf, P_{ns} = 716 lbf, c = 1.000
- No. 20 Gage (0.0358 in.) – P_{nf} = 1,795 lbf, P_{ns} = 869 lbf, c = 1.000
- No. 18 Gage (0.0474 in.) – P_{nf} = 2,348 lbf, P_{ns} = 1,151 lbf, c = 1.000

²Frame fastener patterns recognized for specific deck type, frame fastener, sidelap combinations are shown in [Table 4](#).

³Noted minimum recommended sidelap connection spacings given for Hilti S-SLC 01 M HWH, S-SLC 02 M HWH, S-MD 10-16x3/4 M HWH3, S-MD 10-16x3/4 HWH3 M9, S-MD 12-24x7/8 M HWH4, and S-MD 12-24x7/8 HWH4 M9 screw sidelap connectors and button punch sidelap connections. For Verco VSC2 connections, the minimum recommended sidelap connection spacing for these configurations is 4 inches.

⁴For 36/9 and 36/11 patterns, when allowable seismic (or wind) diaphragm shear capacities exceed the values as shown below, the fastening pattern must be increased at the building perimeter, chords, collectors, or other shear transfer elements to two fasteners per rib (i.e., 36/14 pattern). The allowable seismic (or wind) diaphragm shear capacity must not be greater than that determined from the 36/9 and 36/11 patterns, as applicable.

S-RT5+ M9 – with steel support framing thicknesses < 3/16 inch

- No. 22 Gage (0.0295 in.) – 1,200 plf (1,275 plf)
- No. 20 Gage (0.0358 in.) – 1,500 plf (1,600 plf)
- No. 18 Gage (0.0474 in.) – 1,700 plf (1,825 plf)

S-RT5+ M9 – with steel support framing thicknesses ≥ 3/16 inch

- No. 22 Gage (0.0295 in.) – 1,300 plf (1,400 plf)
- No. 20 Gage (0.0358 in.) – 1,600 plf (1,700 plf)
- No. 18 Gage (0.0474 in.) – 2,100 plf (2,250 plf)
- No. 16 Gage (0.0598 in.) – 2,600 plf (2,775 plf)

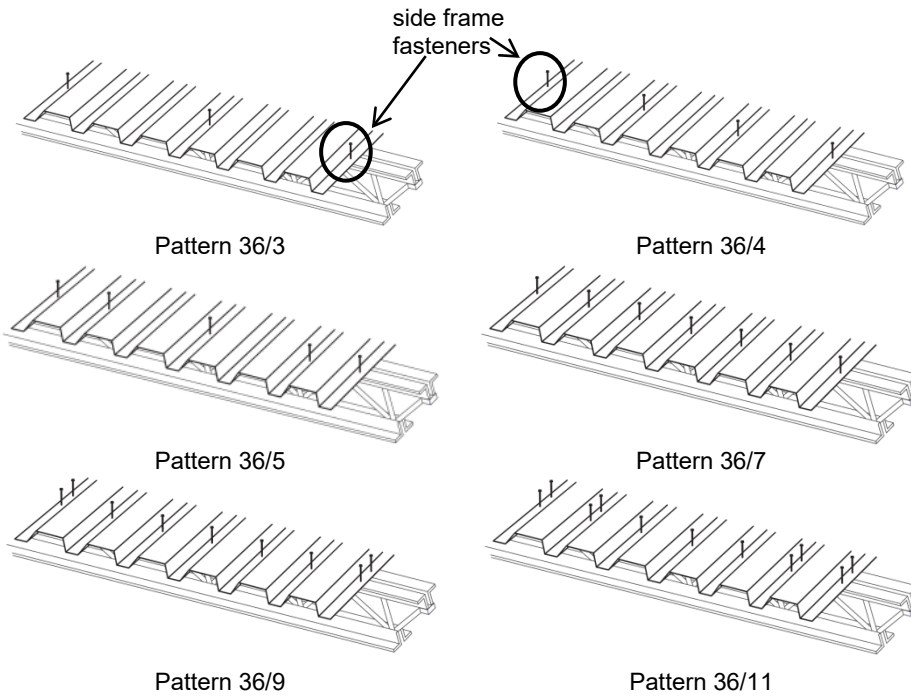

Notes:

1. B-Deck shown for illustration purposes only. See [Figure 4](#) for applicable deck types.
2. Bar joist shown for illustration purposes only. Connection to structural steel members and gage purlins also allowed by this report as set forth in [Table 1](#).
3. For B-Deck, the side frame fasteners are installed through both connecting steel decks and into the supporting framing.
4. For BI-Deck and Verco PLB Deck, the same number of side frame fasteners are installed on each side of the sidelap and into supporting framing.

FIGURE 1—B-, BI- AND PLB DECK FRAME FASTENER PATTERNS

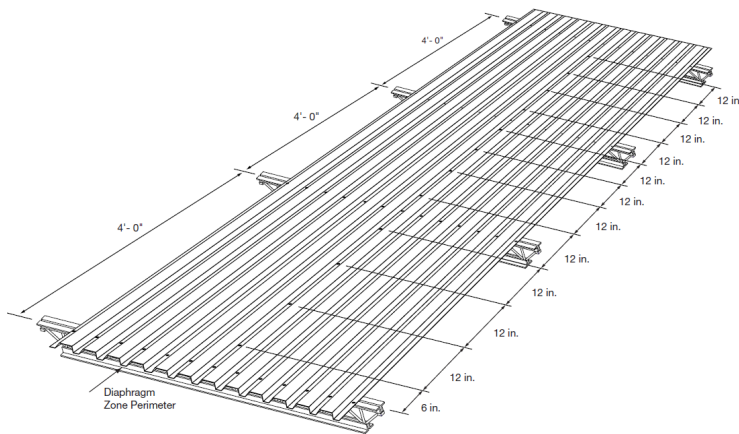

2a: SPECIFIED BY SIDELAP CONNECTOR SPACING (SS)

Example: A 4'-0" span with a 12 in. sidelap connector spacing will typically start 6 in. from the first joist / beam line at the diaphragm zone perimeter, and then have equal spacings of 12 in. across the entire diaphragm length or width, off-set at the interior joist / beam locations. The interior joist / beam fastening locations are frame fasteners and not sidelap connectors. This convention of specifying sidelap connectors by spacing does not consider each deck span independently as a discrete element, but rather as a larger steel deck diaphragm system consisting of 3 or more spans.

Note: If the sidelap connector spacing does not divide evenly into the span length, some spans may have more sidelap connectors than adjacent spans. For this reason, n_e and n_s may not be whole numbers.

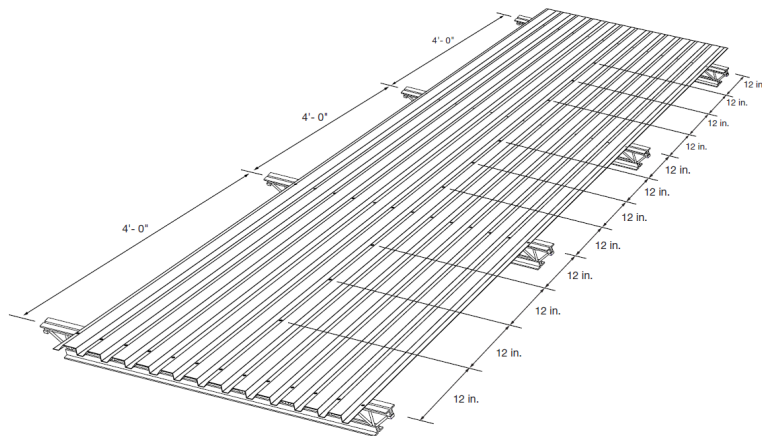

2b: SPECIFIED BY NUMBER OF SIDELAP CONNECTORS PER SPAN (SPS)

Example: A 4'-0" span specified with 3 sidelap connectors per span will have 3 sidelap connectors evenly spaced 12 in. from each joist/ beam line and each other making 4 equal 12 in. spaces per span. This convention of specifying sidelap connectors by the number of sidelap connectors per span considers each deck span independently as a discrete element.

FIGURE 2—EXAMPLE ILLUSTRATION OF SIDELAP CONNECTOR SPECIFICATION CONVENTIONS SPACING OR NUMBER PER SPAN

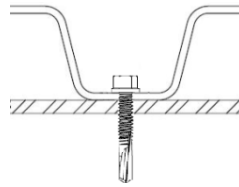

3a. S-MD 12-24 x 1⁵/₈ or S-RT5+ M9 Fastener Attachment of Steel Deck to Frame

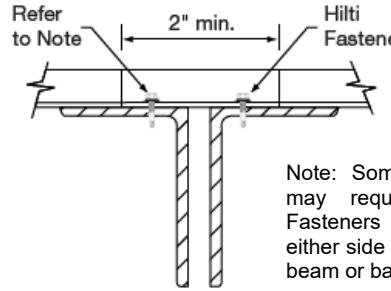

Note: Some fastener patterns may require two fasteners. Fasteners may be installed on either side of the structural steel beam or bar joist.

3b. Steel Deck Endlap Condition

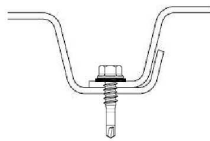

3c. Sidelap Connector with B Deck

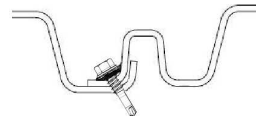

3d. Sidelap Connector with BI Deck with screwable sidelap

- ① PunchLok®II system connection - "2M/3F" condition as shown, the side of the tool with two blades starts off placed on the male side of the sidelap.
- ② Sheared surface of male leg.
- ③ Sheared surface of female leg.
- ④ Male leg / sheet.
- ⑤ Female leg / sheet.

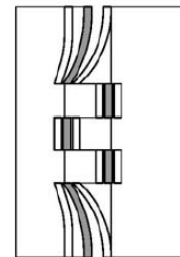
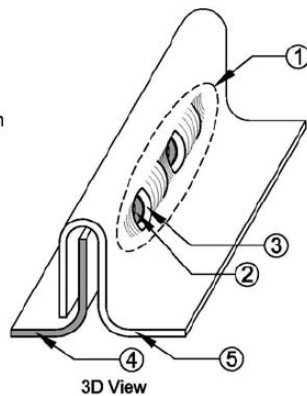

Plan Section A-A

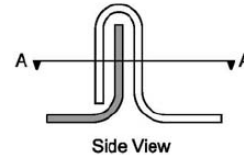

Side View

3e. Vercor VSC 2 Connection for use with PLB only

FIGURE 3—TYPICAL FRAME, ENDLAP AND SIDELAP CONNECTIONS

Deck Type	Nominal Dimensions	Deck Type	Nominal Dimensions
B-Deck		BI-Deck and Vercor PLB Deck	

Notes:

- 1. B-Deck (nestable) and BI-Deck (interlocking) deck panel thicknesses must be 16, 18, 20 or 22 gage steel [(54, 43, 33 or 27 mil designations) (0.0598, 0.0474, 0.0358 or 0.0295 inch) (1.51, 1.21, 0.91 or 0.76 mm)], respectively. Intermediate steel deck panel thicknesses may be used (Reference Section 5.5 of this report).
- 2. PLB (interlocking) deck panel thicknesses must be 16, 18, 20 or 22 gage steel [(54, 43, 33 or 27 mil designations) (0.0598, 0.0478, 0.0359 or 0.0299 inch) (1.51, 1.21, 0.91 or 0.76 mm)], respectively. Intermediate steel deck panel thicknesses may be used (Reference Section 5.5 of this report).
- 3. BI-Deck (interlocking) deck panels must have screwable sidelap edges for use with Hilti SLC01 and SLC02 sidelap connectors and Hilti No. 10 x 3/4 HWH screws.

FIGURE 4—STEEL DECK PANELS

Given:

Load Type: Seismic Design
 Support Span, L_v : 6 ft
 Number of Spans: 3
 Total Length, L : 18 ft (not including allowance for end laps)
 Deck: No. 20 gage ($t = 0.0358$ in) 1-1/2 B-Deck ($F_y = 50$ ksi)
 Support Framing: Steel Bar Joist with 1/4 in. Thick Top Chord
 Frame Fastener: S-RT5+ M9
 Frame Fastener Pattern: 36/7
 Sidelap Fastener: S-SLC 02 M HWH
 Sidelap Fastener Spacing: 12 in. o.c.

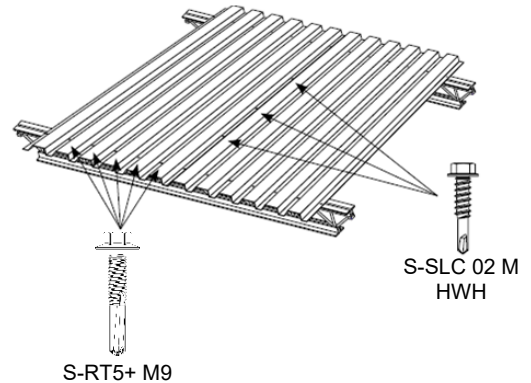
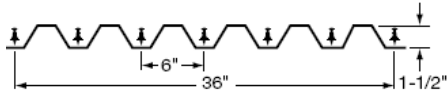

Problem:

Determine allowable (ASD) diaphragm design shear strength ($\frac{S_n}{\Omega}$) and stiffness (G') for the given steel deck diaphragm.

Step 1: Calculate Nominal Diaphragm Shear Strength Limited by Interior Panel Fasteners:

$$S_{ni} = [2A(\lambda - 1) + \beta] \frac{P_{nf}}{L} = [2 \times 1(0.802 - 1) + 16.99] \frac{2,107}{18} = 1,942 \text{ plf}$$

AISI S310 Eq. D1-1

Where:

- $A = 1$
- $P_{nf} = 2,107 \text{ lb}$
- $L = 18 \text{ ft}$
- $D_d = 1.5 \text{ in}$
- $L_v = 6 \text{ ft}$
- $t = 0.0358 \text{ in}$
- $SS = 12 \text{ in}$
- $n_p = 2$
- $P_{ns} = 1,260 \text{ lb}$
- $w = 36 \text{ in}$

ESR-3693 [Table 3](#)
 ESR-3693 [Table 4](#)

$$\sum x_p^2 = 1,008 \text{ in}^2$$

$$\sum x_e^2 = 1,008 \text{ in}^2$$

ESR-3693 [Table 4](#)

$$\lambda = 1 - \frac{D_d L_v}{240 \sqrt{t}} = 1 - \frac{1.5 \times 6}{240 \sqrt{0.0358}} = 0.802 \geq 0.7$$

$$n_s = \frac{12L}{SS} = \frac{12 \times 18}{12} = 18$$

ESR-3693 [Table 3](#)
 ESR-3693 [Table 3](#)

$$\alpha_s = \frac{P_{ns}}{P_{nf}}$$

AISI S310 Eq. D1-5a

$$\alpha_p^2 = \left(\frac{1}{w^2}\right) \sum x_p^2$$

AISI S310 Eq. D1-7

$$\alpha_e^2 = \left(\frac{1}{w^2}\right) \sum x_e^2$$

AISI S310 Eq. D1-8

AISI S310 Eq. D1-9

$$\begin{aligned} \beta &= n_s \alpha_s + 2n_p \alpha_p^2 + 4\alpha_e^2 = n_s \frac{P_{ns}}{P_{nf}} + 2n_p \left(\frac{1}{w^2}\right) \sum x_p^2 + 4 \left(\frac{1}{w^2}\right) \sum x_e^2 \\ &= 18 \frac{1,260}{2,107} + 2 \times 2 \left(\frac{1}{36^2}\right) 1,008 + 4 \left(\frac{1}{36^2}\right) 1,008 = 16.99 \end{aligned}$$

AISI S310 Eq. D1-6

Step 2: Calculate Nominal Diaphragm Shear Strength Limited by Corner Fasteners:

$$S_{nc} = \left(\frac{N^2 \beta^2}{L^2 N^2 + \beta^2}\right)^{0.5} \times P_{nf} = \left(\frac{2^2 \times 16.99^2}{18^2 \times 2^2 + 16.99^2}\right)^{0.5} \times 2,107 = 1,798 \text{ plf}$$

AISI S310 Eq. D1-2

Where:

- $N = 2$
- $\beta = 16.99$ (from Step 1)
- $L = 18 \text{ ft}$
- $P_{nf} = 2,107 \text{ lb}$

ESR-3693 [Table 3](#)

ESR-3693 [Table 4](#)

Step 3: Calculate Nominal Diaphragm Shear Strength Limited by Edge Fasteners:

$$S_{ne} = \frac{(2\alpha_1 + n_p\alpha_2)P_{nf} + n_e P_{nfs}}{L} = \frac{(2 \times 2 + 2 \times 2)2,107 + 18 \times 2,107}{18} = 3,043 \text{ plf}$$

AISI S310 Eq. D1-3

Where:

$$\alpha_1 = 2$$

$$n_p = 2$$

$$\alpha_2 = 2$$

$$P_{nf} = 2,107 \text{ lb}$$

$$P_{nfs} = 2,107 \text{ lb}$$

$$L = 18 \text{ ft}$$

$$SS = 12 \text{ in}$$

$$n_e = \frac{12L}{SS} = \frac{12 \times 18}{12} = 18$$

ESR-3693 [Table 3](#)ESR-3693 [Table 3](#)ESR-3693 [Table 4](#)ESR-3693 [Table 4](#)**Step 4: Calculate Nominal Diaphragm Shear Strength Limited by Edge Fasteners:**

$$S_{np} = n_d \times P_{nf} \times \frac{1}{W_t} = 1 \times 2,107 \times \frac{1}{0.5} = 4,214 \text{ plf} \quad (\text{For fluted Panels})$$

AISI S310 Eq. D1-4a

Where:

$$n_d = 1$$

$$P_{nf} = 2,107 \text{ lbs}$$

$$W_t = 6" = 0.5 \text{ ft}$$

1 fastener per flute

ESR-3693 [Table 4](#)

Tributary width for "B" deck

Step 5: Calculate Nominal Diaphragm Shear Strength Controlled by Connections and Adjusted by the Correlation Factor:

$$S_{nf} = \min[S_{ni}, S_{nc}, S_{np} \text{ and } S_{ne}] c = 1,798 \times 1.127 = 2,026 \text{ plf}$$

Where:

$$c = 1.127$$

ESR-3693 [Table 4](#)**Step 6: Calculate Allowable Diaphragm Shear Strength:**

$$\frac{S_{nf}}{\Omega_{nf}} = \frac{2,026}{2.30} = 881 \text{ plf}$$

Where:

$$\Omega_{nf} = 2.30$$

ESR-3693 [Table 6](#)**Step 7: Select Controlling Diaphragm Buckling Strength and Calculate Allowable Diaphragm Buckling Strength:**

$$\frac{S_{nb}}{\Omega_{nb}} = \min\left(\frac{S_{no}}{\Omega_{no}} \text{ \& } \frac{S_{nl}}{\Omega_{nl}}\right) = 2,350 \text{ plf}$$

ESR-3693 [Table 7](#)**Step 8: Determine Controlling Allowable Diaphragm Shear Strength:**

$$\frac{S_n}{\Omega} = \min\left[\frac{S_{nf}}{\Omega_{nf}}, \frac{S_{nb}}{\Omega_{nb}}\right] = \min[(881), (2,350)] = 881 \text{ plf}$$

AISI S310 Eq. D-1

Where:

$$\frac{S_{nf}}{\Omega_{nf}} = 881 \text{ plf (from Step 6)}$$

$$\frac{S_{nb}}{\Omega_{nb}} = 2,350 \text{ plf (from Step 7)}$$

Step 9: Determine Diaphragm Stiffness:

$$G' = \left(\frac{Et}{2(1 + \mu) \frac{s}{d} + \gamma_c D_n + C} \right) K = \left(\frac{29,500 \times 0.0358}{2(1 + 0.3)1.365 + 0.9 \frac{924}{216} + 3.65} \right) 1 = 95.6 \text{ kip/in}$$

AISI S310 Eq. D5.1.1-1

Where:

$E = 29,500 \text{ ksi}$

$t = 0.0358 \text{ in}$

$\mu = 0.3$

$\frac{s}{d} = 1.365$

$\gamma_c = 0.9$

$K = 1$

$w = 36 \text{ in}$

$L = 216 \text{ in}$

$\alpha_3 = 2$

$n_p = 2$

$\alpha_4 = 2$

$n_s = 18 \text{ (from Step 1)}$

$S_f = 0.0066 \text{ in/kip}$

$S_s = 0.0159 \text{ in/kip}$

$D_n = \frac{D}{L}$

$D = 924 \text{ in}$

ESR-3693 [Table 3](#)

ESR-3693 [Table 3](#)

ESR-3693 [Table 3](#)

ESR-3693 [Table 5](#)

ESR-3693 [Table 5](#)

AISI S310 Eq. 1.4-1

ESR-3693 [Table 3](#)

$$C = \left(\frac{Et}{w} \right) \left(\frac{2L}{2\alpha_3 + n_p \alpha_4 + 2n_s \frac{S_f}{S_s}} \right) S_f = \left(\frac{29,500 \times 0.0358}{36} \right) \left(\frac{2 \times 216}{2 \times 2 + 2 \times 2 + 2 \times 18 \frac{0.0066}{0.0159}} \right) 0.0066 = 3.65$$

AISI S310 Eq. D5.1.1-2

FIGURE 5—DIAPHRAGM DESIGN EXAMPLE

DIVISION: 05 00 00—METALS
Section: 05 05 23—Metal Fastenings
Section: 05 31 00—Steel Decking

REPORT HOLDER:

HILTI, INC.

EVALUATION SUBJECT:

STEEL DECK DIAPHRAGMS ATTACHED WITH HILTI S-MD 12-24 x 1⁵/₈ M OR S-RT5+ M9 FRAME FASTENERS AND HILTI S-SLC 01 M HWH, S-SLC 02 M HWH, OR S-MD 10-16 x 3³/₄ M HWH3, S-MD 10-16 x 3³/₄ HWH3 M9, S-MD 12-24 x 7⁷/₈ M HWH4, AND S-MD 12-24 x 7⁷/₈ HWH4 M9 SCREW SIDELAP CONNECTORS, VERCO VSC2 SIDELAP CONNECTIONS, OR BUTTON PUNCH SIDELAP CONNECTIONS

1.0 REPORT PURPOSE AND SCOPE

Purpose:

The purpose of this evaluation report supplement is to indicate that Steel Deck Diaphragms attached with Hilti S-MD 12-24 x 1⁵/₈ M or S-RT5+ M9 Frame Fasteners and HILTI S-SLC 01 M HWH, S-SLC 02 M HWH, or S-MD 10-16 x 3³/₄ M HWH3, S-MD 10-16 x 3³/₄ HWH3 M9, S-MD 12-24 x 7⁷/₈ M HWH4, and S-MD 12-24 x 7⁷/₈ HWH4 M9 Screw Sidelap Connectors, VERCO VSC2 Sidelap Connections, or Button Punch Sidelap Connections, described in ICC-ES evaluation report [ESR-3693](#), have also been evaluated for compliance with the codes noted below as adopted by the Los Angeles Department of Building and Safety (LADBS).

Applicable code edition:

- 2023 City of Los Angeles Building Code ([LABC](#))

2.0 CONCLUSIONS

The Steel Deck Diaphragms attached with Hilti S-MD 12-24 x 1⁵/₈ M or S-RT5+ M9 Frame Fasteners and HILTI S-SLC 01 M HWH, S-SLC 02 M HWH, or S-MD 10-16 x 3³/₄ M HWH3, S-MD 10-16 x 3³/₄ HWH3 M9, S-MD 12-24 x 7⁷/₈ M HWH4, and S-MD 12-24 x 7⁷/₈ HWH4 M9 Screw Sidelap Connectors, VERCO VSC2 Sidelap Connections, or Button Punch Sidelap Connections, described in Sections 2.0 through 7.0 of the evaluation report [ESR-3693](#), comply with the LABC Chapter 22, and are subjected to the conditions of use described in this supplement.

3.0 CONDITIONS OF USE

The Steel Deck Diaphragms attached with Hilti S-MD 12-24 x 1⁵/₈ M or S-RT5+ M9 Frame Fasteners and HILTI S-SLC 01 M HWH, S-SLC 02 M HWH, or S-MD 10-16 x 3³/₄ M HWH3, S-MD 10-16 x 3³/₄ HWH3 M9, S-MD 12-24 x 7⁷/₈ M HWH4, and S-MD 12-24 x 7⁷/₈ HWH4 M9 Screw Sidelap Connectors, VERCO VSC2 Sidelap Connections, or Button Punch Sidelap Connections described in this evaluation report supplement must comply with all of the following conditions:

- All applicable sections in the evaluation report [ESR-3693](#).
- The design, installation, conditions of use and identification are in accordance with the 2021 *International Building Code*® (IBC) provisions noted in the evaluation report [ESR-3693](#).
- The design, installation and inspection are in accordance with additional requirements of LABC Chapters 16 and 17, as applicable.
- Diaphragm shear strength values in the evaluation report must not be increased for load combinations that include wind or seismic loads.
- For diaphragms that are used to provide wall anchorage, the adequacy of the steel deck panel end and side seam connections must be verified by a registered design professional to the satisfaction of the code official.

This supplement expires concurrently with the evaluation report, reissued May 2025.

DIVISION: 05 00 00—METALS
Section: 05 05 23—Metal Fastenings
Section: 05 31 00—Steel Decking

REPORT HOLDER:

HILTI, INC.

EVALUATION SUBJECT:

STEEL DECK DIAPHRAGMS ATTACHED WITH HILTI S-MD 12-24 x 1⁵/₈ M OR S-RT5+ M9 FRAME FASTENERS AND HILTI S-SLC 01 M HWH, S-SLC 02 M HWH, OR S-MD 10-16 x 3³/₄ M HWH3, S-MD 10-16 x 3³/₄ HWH3 M9, S-MD 12-24 x 7⁷/₈ M HWH4, AND S-MD 12-24 x 7⁷/₈ HWH4 M9 SCREW SIDELAP CONNECTORS, VERCO VSC2 SIDELAP CONNECTIONS, OR BUTTON PUNCH SIDELAP CONNECTIONS

1.0 REPORT PURPOSE AND SCOPE

Purpose:

The purpose of this evaluation report supplement is to indicate that the fasteners, described in ICC-ES evaluation report [ESR-3693](#), have also been evaluated for compliance with the code noted below.

Applicable code edition:

- 2023 Florida Building Code—Building

2.0 CONCLUSIONS

The fasteners described in Sections 2.0 through 7.0 of ICC-ES evaluation report [ESR-3693](#), comply with the *Florida Building Code—Building*. The design requirements must be determined in accordance with Florida Building Code—Building. The installation requirements noted in ICC-ES evaluation report [ESR-3693](#) for the 2021 *International Building Code*® (IBC) meet the requirements of the Florida Building Code—Building.

References to ASCE/SEI 7-16/S1 in [ESR-3693](#) shall be replaced with ASCE/SEI 7-22. This is necessary as the 2023 *Florida Building Code—Building* references ASCE/SEI 7-22 and the 2021 *International Building Code*® references ASCE/SEI 7-16/S1.

Use of the fasteners has also been found to be in compliance with the High-Velocity Hurricane Zone provisions of the *Florida Building Code—Building* and must comply with the following Condition of Use:

When the fasteners are used with 22 gage or less (thinner) steel decking, the steel decking must be minimum G90 galvanizing in accordance with Section 2222.6.1 of the FBC.

For products falling under Florida Rule 61G20-3, verification that the report holder's quality assurance program is audited by a quality assurance entity approved by the Florida Building Commission for the type of inspections being conducted is the responsibility of an approved validation entity (or the code official, when the report holder does not possess an approval by the Commission). Florida Rule 61G20-3 is applicable to products and/or systems which comprise the building envelope and structural frame for compliance with the structural requirements of the *Florida Building Code*.

This supplement expires concurrently with the evaluation report, reissued May 2025.