

## Ties & Anchors - Miscellaneous

# 345-BT Flexible Tie

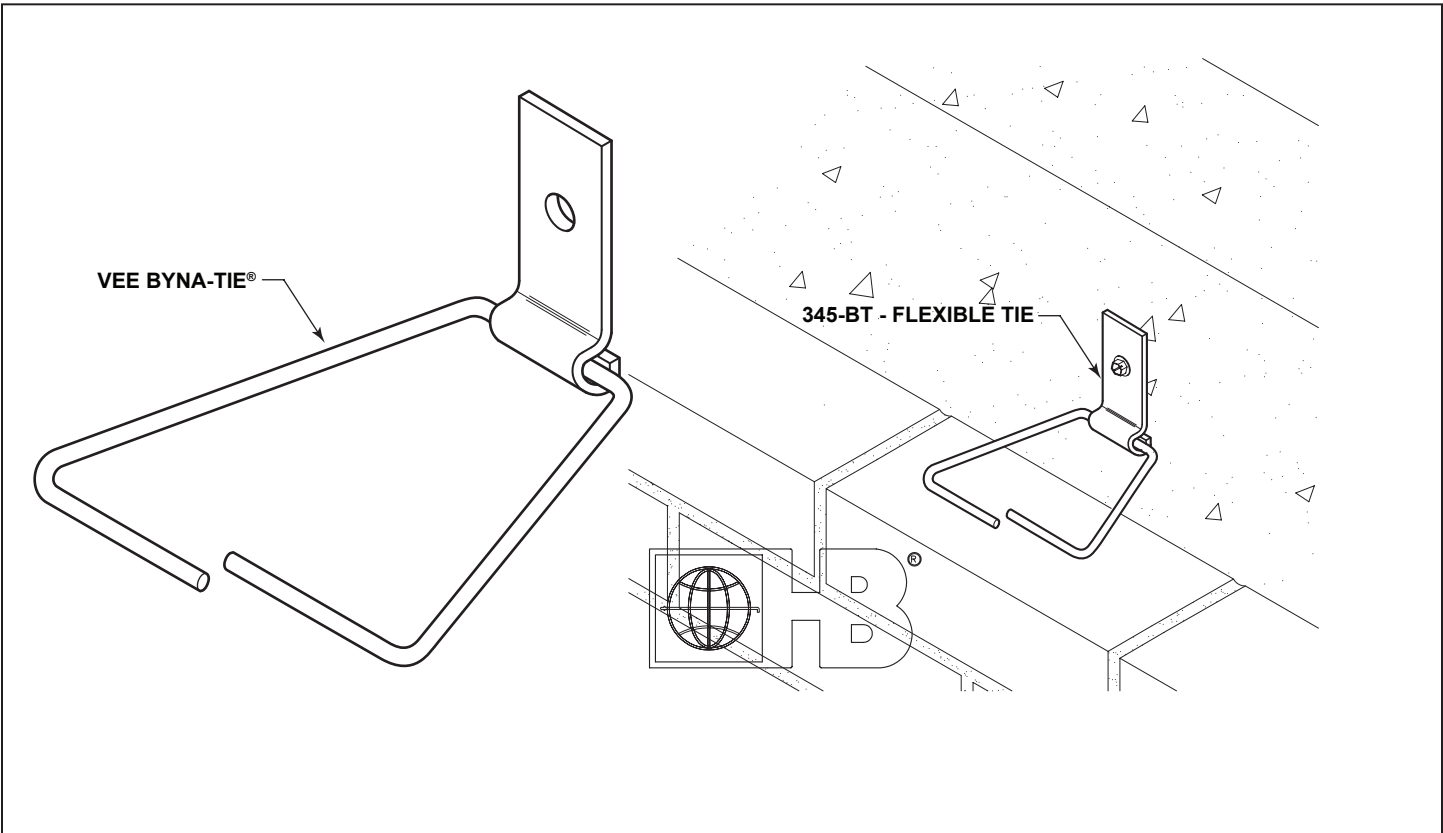

DRAWINGS FOR ILLUSTRATIVE PURPOSES ONLY

**345-BT Flexible Tie**, Vee Byna-Tie® with a wrap-around metal strap for tying masonry to concrete or CMU backup with a flexible connection.

**MATERIAL CONFORMANCE**

**Wire (Carbon Steel):** Prefabricated from cold-drawn steel wire conforming to **ASTM A1064/A1064M**

Tensile Strength - 80,000 p.s.i. | Yield Point - 70,000 p.s.i. minimum  
Zinc Coating:

Hot-Dip Galvanized: **ASTM A153/A153M Class B** (1.5 oz/ft<sup>2</sup>) (sheet metal ties and anchors galvanized after fabrication)

Note: Hohmann & Barnard will certify to a minimum of 2.0 oz/ft<sup>2</sup>

**Wire (Stainless Steel):**

**ASTM A580/A580M** - AISI Type 304 (Type 316 available on special order)

**Sheet Metal (Carbon Steel):**

ASTM A1008/A1008M

Zinc Coating:

Hot-Dip Galvanized: (refer to wire above)

Note: Hohmann & Barnard will certify to a minimum of 2.0 oz/ft<sup>2</sup>

**Sheet Metal (Stainless Steel):**

**ASTM A666, ASTM A480/480M, and ASTM A240/A240M**

**AISI Type 304 or 316**

**Finishes:**

Hot-Dip Galv. | Stainless Steel:  Type 304  Type 316

**Note: Hohmann & Barnard recommends Stainless Steel for maximum protection against corrosion.**

**Flexible Head Thickness:** (3/4" wide with a 5/16" hole)

12 gauge (heavyweight)

**Vee Byna-Tie® Length:**

3"       3 1/2"       4"       4 1/2"  
 5"       6"       7"       Other \_\_\_\_\_

**Vee Byna-Tie® Diameter**

3/16"Ø (standard)       1/4"Ø (heavyweight)

**Vee Byna-Tie component manufactured from a minimum of 95% recycled material.**

**IMPORTANT:** Since each construction project is unique, the appropriate selection and use of any product contained herein must be determined by competent architects, engineers and other appropriate professionals who are familiar with the specific requirements of the project in question. This drawing and/or data sheet is the confidential and proprietary information of Hohmann & Barnard, Inc. and is not to be reproduced, copied or disclosed, in whole or in part, without the prior written consent of H&B.