

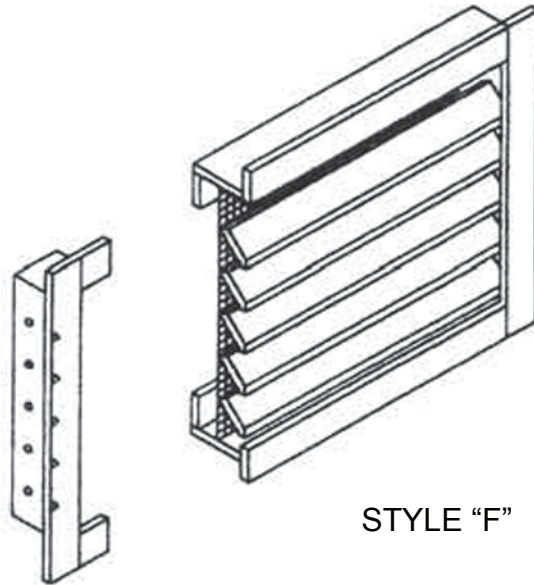

HOHMANN & BARNARD, INC.
A MiTek - BERKSHIRE HATHAWAY COMPANY

Aluminum Brick Vents

Extruded Aluminum Brick Vent - Style "F"



STYLE "F"

DRAWINGS FOR ILLUSTRATIVE PURPOSES ONLY

Style "F" Brick Vent Description:

- Extruded Aluminum, minimum .125" 6063-T5 alloy
- 1 1/2" deep with 1" flanges
- Extruded stop for screen retention
- Overlapping blades, all at 45°, with storm lip
- Continuous weepage on bottom
- Standard 204-RI clear anodized finish (Non-standard finishes include medium or dark bronze anodized, kynar or baked enamel.)
- Special custom sizes available
- Lengths up to 8 ft. available without front mullions-continuous blade effect.

Note: Can be equipped with operable damper and ducts

Free Area Calculations: (measurements expressed in Square Feet)

Width (in inches)	Outside Height (in inches)				
	2 3/8"	4 3/4"	7 3/4"	11 3/4"	15 3/4"
8"	.029	.080	.136	.207	.279
12"	.044	.120	.204	.310	.418
15 5/8"	.056	.156	.263	.400	.540
16 1/2"	.060	.196	.280	.426	.575
24"	.088	.271	.408	.620	.836
32"	.117	.321	.543	.816	1.115

H&B manufactures aluminum brick vents from a minimum of 41% pre-consumer and 23% post-consumer recycled material.

Model Number

W x H (Nominal)

<input type="checkbox"/> F 825	8 1/8" x 2 3/8"
<input type="checkbox"/> F 847	8 1/8" x 4 3/4"
<input type="checkbox"/> F 808	8 1/8" x 7 3/4"
<input type="checkbox"/> F 125	12" x 4 3/4"
<input type="checkbox"/> F 128	12" x 7 3/4"
<input type="checkbox"/> F 1212	12" x 11 3/4"
<input type="checkbox"/> F 157	15 5/8" x 7 3/4"
<input type="checkbox"/> F 1516	15 5/8" x 15 3/4"
<input type="checkbox"/> F 162	16 1/2" x 2 3/8"
<input type="checkbox"/> F 164	16 1/2" x 4 3/4"
<input type="checkbox"/> F 168	16 1/2" x 7 3/4"
<input type="checkbox"/> F 1616	16 1/2" x 15 3/4"
<input type="checkbox"/> F 244	24" x 4 3/4"
<input type="checkbox"/> F 248	24" x 7 3/4"
<input type="checkbox"/> F 3208	32" x 7 3/4"
<input type="checkbox"/> F 4808	48" x 7 3/4"
<input type="checkbox"/> Custom _____	

Note: "F" Vents add 1" face flange on 4 sides to nominal size. Add 1/4" to nominal width for mechanical fastener heads.

Mullions: YES NO

*Vents can be made to any specified height or width WITHOUT exposed mullions.

HOHMANN & BARNARD, Inc.
30 Rasons Court | Hauppauge, NY 11788
CORPORATE HEADQUARTERS
T: 800.645.0616 F: 631.234.0683
www.h-b.com

Branch/Subsidiary Locations:
ALABAMA - ILLINOIS - MARYLAND
NEW YORK - PENNSYLVANIA - TEXAS
CANADA

© HOHMANN & BARNARD, INC. - 2012