

## Seismic Anchors and Ties

# HB-213-2X SH

Adjustable Veneer Anchor with 2X-SEISMIC HOOK

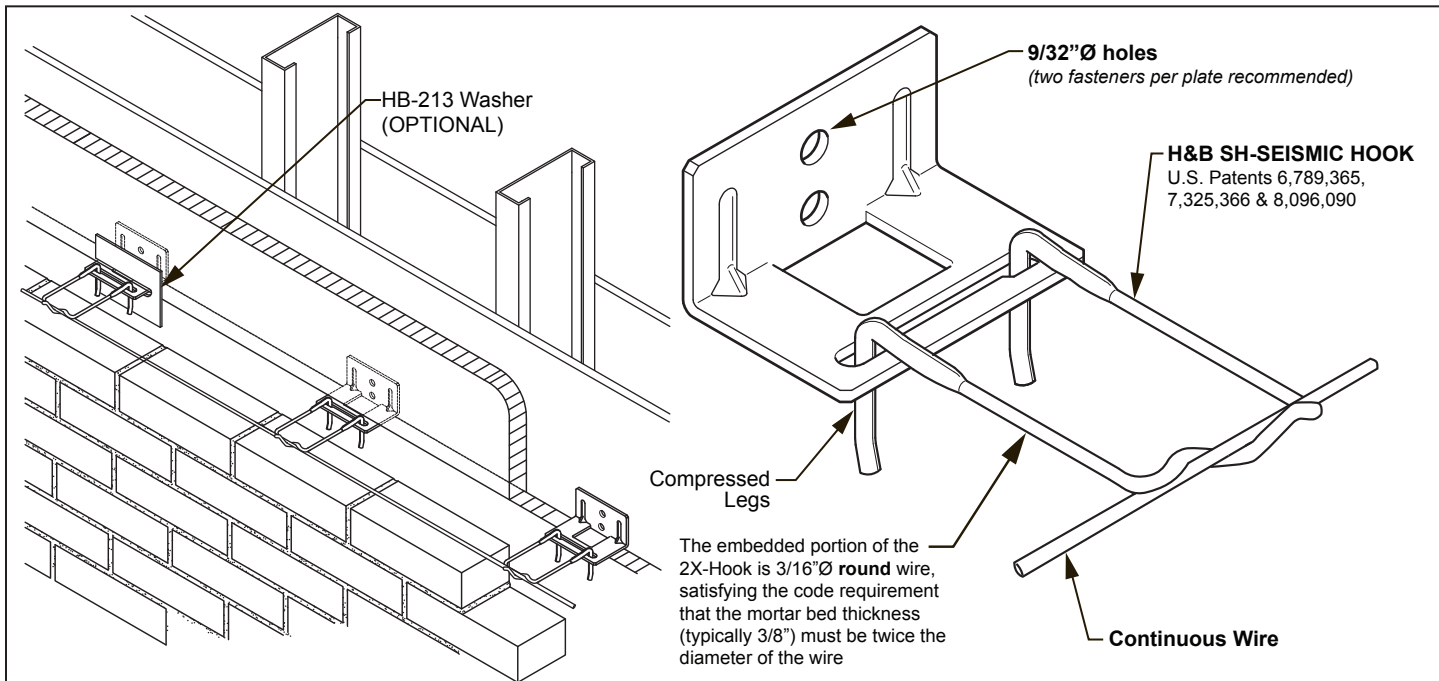

DRAWINGS FOR ILLUSTRATIVE PURPOSES ONLY

**H&B RECOMMENDS 16" X 16" SPACING**

Hohmann & Barnard's 2X-Hook has been tested and designed to withstand over 200-lbf, in tension or compression, at maximum allowed offset (TMS 402/602-16 12.2.2.5.5.4) of 1/4" (disengagement of the pintle from the veneer anchor). These results exceed BIA recommendations and the capabilities of standard "round wire" hooks/pintles by over 100%, while maintaining the ASTM A1064/1064M wire specification.

Test results available upon request.

U.S. Pat. No. 8,613,175

HB-213 is designed to anchor masonry to a structure, accommodating rigid insulation up to 6 inches (75mm) thick. Furnished with two 9/32"Ø holes. Used with H&B SH-SEISMIC HOOK. to accommodate 9 ga. or 3/16"Ø continuous wire for seismic zones.

### NOTES:

- Custom dimensions/gauges available on special order
- State overall wall size & cavity or insulation thickness when ordering
- Two fasteners per plate recommended
- Needs 3/4 inch (19mm) to 1 inch (25mm) minimum air cavity
- For attachment to concrete, block or brick see 523 Brass Expansion Bolt

### MATERIAL CONFORMANCE

#### Wire

**Carbon Steel Wire:** Cold-drawn steel wire conforming to ASTM A1064/A1064M:  
Tensile Strength - 80,000 psi | Yield Point - 70,000 psi minimum

**Zinc Coating:** Hot-Dip Galvanized after fabrication: **ASTM A153/A153M-B2** (1.5 oz/ft<sup>2</sup>)

**Stainless Steel Wire:** **ASTM A580/A580M** - AISI Type 304 or Type 316

H&B manufactures steel wire products from a minimum of 95% recycled material.

#### Sheet Metal

**Carbon Steel:** **ASTM A1008/A1008M**

**Zinc Coating:** Hot-Dip Galvanized: (refer to wire above)

**Stainless Steel:** **ASTM A666, ASTM A480/480M, and ASTM A240/A240M** - AISI Type 304 or 316

### HB-213 Anchor Backplate Finish:

- Hot-Dip Galvanized |  Stainless Steel  Type 304  Type 316  
H&B recommends Stainless Steel for maximum protection against corrosion

### Backplate Style (Equal to combined thickness of insulation and/or wallboard):

- |  |  |  |
|--|--|--|
| <input type="checkbox"/> HB-213 (0")     | <input type="checkbox"/> HB-213 (1")     | <input type="checkbox"/> HB-213 (1 1/2") |
| <input type="checkbox"/> HB-213 (2")     | <input type="checkbox"/> HB-213 (2 1/2") | <input type="checkbox"/> HB-213 (3")     |
| <input type="checkbox"/> HB-213 (3 1/2") | <input type="checkbox"/> HB-213 (4")     | <input type="checkbox"/> HB-213 (4 1/2") |
| <input type="checkbox"/> HB-213 (5")     | <input type="checkbox"/> HB-213 (5 1/2") | <input type="checkbox"/> HB-213 (6")     |

- CUSTOM Backplate \_\_\_\_\_

### Backplate Thickness:

- 14 ga. (1.9 mm)  12 ga. (2.7 mm)  CUSTOM \_\_\_\_\_

### Compressed Leg 2X-Seismic Hook Finish:

- Hot-Dip Galvanized |  Stainless Steel  Type 304  Type 316

### Compressed Leg Seismic Hook - Length (Model), 3/16"Ø (5mm) wire

- 3" (300-S-2X)  4" (400-S-2X)  5" (500-S-2X)

### Continuous Wire Finish:

- Hot-Dip Galvanized |  Stainless Steel  Type 304  Type 316

- Continuous Wire Diameter:**  9 ga.  3/16"Ø

**IMPORTANT:** Since each construction project is unique, the appropriate selection and use of any product contained herein must be determined by competent architects, engineers and other appropriate professionals who are familiar with the specific requirements of the project in question. This drawing and/or data sheet is the confidential and proprietary information of Hohmann & Barnard, Inc. and is not to be reproduced, copied or disclosed, in whole or in part, without the prior written consent of H&B.