

HOHMANN & BARNARD, INC.
a MiTek company

Veneer Anchor Plates HB-5213-2X S.I.S.

Adjustable Veneer Anchor w/Brass Expansion Bolt & Seismiclip® Interlock System

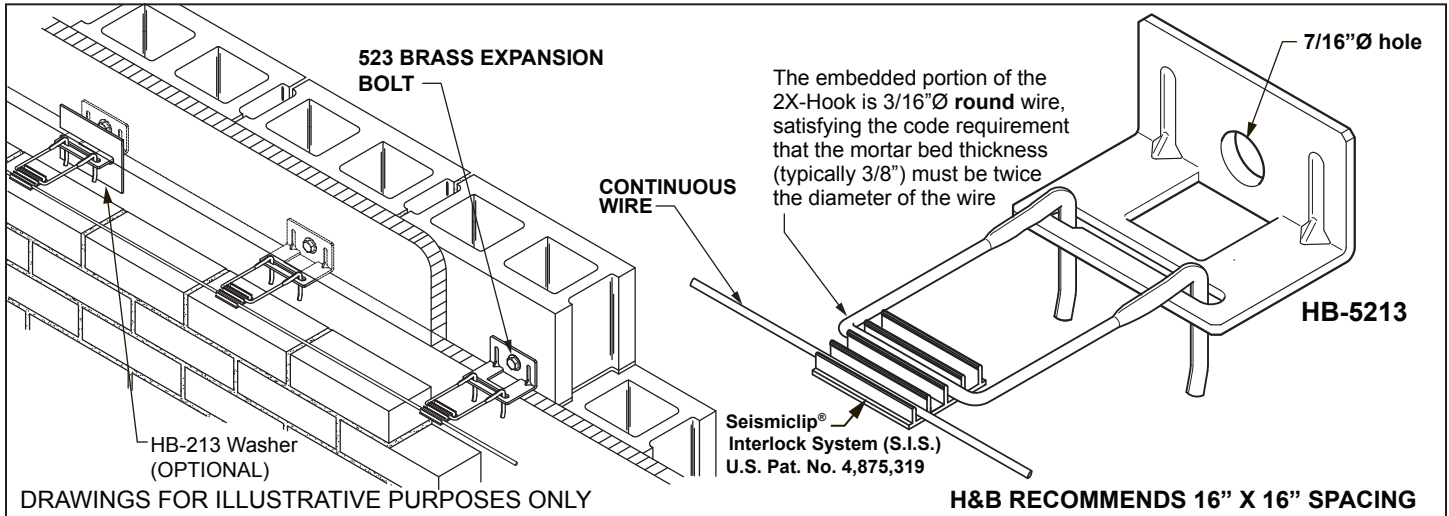

Hohmann & Barnard's 2X-Hook has been tested and designed to withstand over 200-lbf, in tension or compression, at maximum allowed offset (TMS 402/602-16 12.2.2.5.5.4) of 1/4" (disengagement of the pintle from the veneer anchor). These results exceed BIA recommendations and the capabilities of standard "round wire" hooks/pintles by over 100%, while maintaining the ASTM A1064/1064M wire specification. Test results available upon request. U.S. Pat. No. 8,613,175

HB-5213 is designed to anchor masonry to concrete, block or brick, accommodating rigid insulation up to 6 inches (75mm) thick. Furnished with one 7/16"Ø hole for use with 523 Brass Exp. Bolt.

NOTES:

- Custom dimensions/gauges available on special order
- State overall wall size & cavity or insulation thickness when ordering
- Needs 3/4" (19mm) to 1" (25mm) minimum air cavity

MATERIAL CONFORMANCE

Wire (Carbon Steel): Cold-drawn steel wire conforming to ASTM A1064/A1064M: Tensile Strength - 80,000 psi | Yield Point - 70,000 psi minimum
Zinc Coating: Hot-Dip Galvanized after fabrication: ASTM A153/A153M-B2 (1.5 oz/ft²)
Wire (Stainless Steel): ASTM A580/A580M - AISI Type 304 or 316
H&B manufactures steel wire products from a minimum of 95% recycled material.

Sheet Metal (Carbon Steel): ASTM A1008/A1008M
Zinc Coating: Hot-Dip Galvanized: (refer to wire above)

Sheet Metal (Stainless Steel): ASTM A666, ASTM A480/480M, and ASTM A240/A240M - AISI Type 304 or 316

Seismiclip® (U.S. Pat. No. 4,875,319):

Impact-resistant, rigid polyvinyl chloride tested in conformance with: ASTM D1781 (Cell Classification), ASTM D2240 (Hardness Shore D), ASTM D638 (Tensile Yield & Modulus), ASTM D790 (Flexural Strength & Modulus)

HB-5213 Anchor Backplate Finish:

- Hot-Dip Galv. Stainless Steel: Type 304 Type 316

H&B recommends Stainless Steel for maximum protection against corrosion

Backplate Style (Equal to thickness of insulation):

- | | |
|---|---|
| <input type="checkbox"/> HB-5213 (0") | <input type="checkbox"/> HB-5213 (3 1/2") |
| <input type="checkbox"/> HB-5213 (1") | <input type="checkbox"/> HB-5213 (4") |
| <input type="checkbox"/> HB-5213 (1 1/2") | <input type="checkbox"/> HB-5213 (4 1/2") |
| <input type="checkbox"/> HB-5213 (2") | <input type="checkbox"/> HB-5213 (5") |
| <input type="checkbox"/> HB-5213 (2 1/2") | <input type="checkbox"/> HB-5213 (5 1/2") |
| <input type="checkbox"/> HB-5213 (3") | <input type="checkbox"/> HB-5213 (6") |
| <input type="checkbox"/> CUSTOM Backplate _____ | |

Backplate Thickness:

- 14 ga. (1.9 mm) 12 ga. (2.7 mm) CUSTOM _____

3/16"Ø Compressed Leg Hook Length:

- | | | |
|---------------------------------------|---------------------------------------|---------------------------------------|
| <input type="checkbox"/> 3" (300H-2X) | <input type="checkbox"/> 4" (400H-2X) | <input type="checkbox"/> 5" (500H-2X) |
| <input type="checkbox"/> 6" (600H-2X) | <input type="checkbox"/> 7" (700H-2X) | |

3/16"Ø Compressed Leg Hook Finish:

- Hot-Dip Galv. Stainless Steel: Type 304 Type 316

Continuous Wire Finish:

- Hot-Dip Galv. Stainless Steel: Type 304 Type 316

Continuous Wire Diameter: 9 gauge 3/16"Ø

**523 Brass Expansion Bolt
Technical Data:**

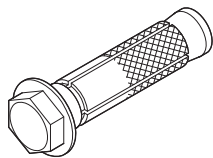

Materials

- Internal Bolt: Type 304 Stainless Steel
- Stainless Steel Washer: Type 18-8 Stainless Steel
- Knurled Expansion Sleeve: Brass 260 Alloy
- Expander Cone: Brass 260 Alloy

Ultimate Structural Values*

- (Tension)
- C-90 CMU Block (Shell) 1720#
 - C-90 CMU Block (Rib) 2015#
 - Brick Masonry 1550#
 - Brick/CMU mortar joint 1435#
 - Concrete (3000psi.) 1785#

Dimensions

- ANSI drill bit size: 3/8"Ø
- Fixture clearance hole: 7/16"Ø
- Internal bolt size: 1/4"Ø - 20
- Head height: 1/4"
- Washer O.D.: 3/4" (carbon steel drill point only)

* Full 1" Embedment. * The ultimate structural values listed above are ultimate load capacities, which should be reduced by a minimum safety factor of 4.0 or greater to determine the allowable working load.

IMPORTANT: Since each construction project is unique, the appropriate selection and use of any product contained herein must be determined by competent architects, engineers and other appropriate professionals who are familiar with the specific requirements of the project in question. This drawing and/or data sheet is the confidential and proprietary information of Hohmann & Barnard, Inc. and is not to be reproduced, copied or disclosed, in whole or in part, without the prior written consent of H&B.

HOHMANN & BARNARD, Inc.
CORPORATE HEADQUARTERS
30 Rasons Court | Hauppauge, NY 11788
T: 800.645.0616 F: 631.234.0683
www.h-b.com

Branch/Subsidiary Locations:
ALABAMA - ARIZONA - ILLINOIS
MARYLAND - NEW YORK
PENNSYLVANIA - TEXAS - UTAH
CANADA

© 2013-2018 MiTek®