

**HOHMANN & BARNARD, INC.**  
a MiTek company

# PTA Series Partition Top Anchors

## PTA 310

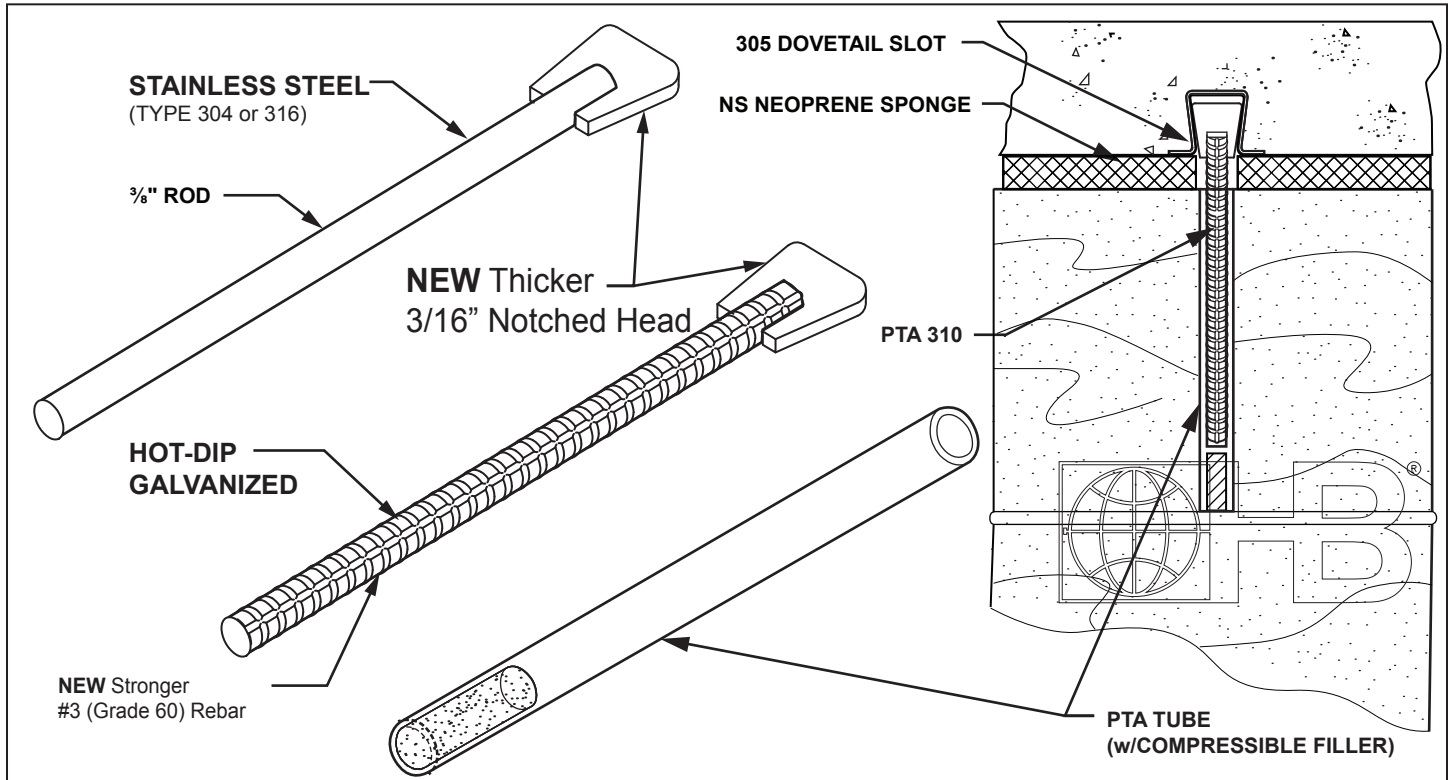

DRAWINGS FOR ILLUSTRATIVE PURPOSES ONLY

**PTA 310** - PTA Series Partition Top Anchors have been developed to provide lateral shear resistance at the upper limit of masonry walls. They permit vertical deflection of the slab above, without transferring compressive loads to the masonry wall below. PTA Series Anchors are suitable for construction using steel or concrete. PTA Tube with expansion filler is placed over rod anchor, which has been attached to concrete or steel by any of the methods illustrated. The vertical joint is then filled with mortar, fully surrounding the tube.

▪ **PTA 310 must be used in conjunction with 305 Dovetail Slot.**

**Sheet Metal (Carbon Steel):**

ASTM A1008/A1008M/A (Cold-rolled)  
ASTM A1011/A1011M (Hot-rolled, pickled and oiled)

**Finishes - Sheet metal (Carbon-Steel):**

Hot-Dip Galvanized - ASTM A153/A153M-B2 class B (sheet metal ties and anchors hot-dip galvanized after fabrication).

Note: Hohmann & Barnard will certify to a minimum zinc coating of 2.0 oz./ft.<sup>2</sup>

**Sheet Metal (Stainless Steel):**

ASTM A 666, ASTM A480/480M, and ASTM A240/A240M  
AISI Type 304 or 316

**Rod (#3 rebar):**

Hot-Dip Galvanized - ASTM A153/A153M-B2  
Stainless Steel Type 304 - ASTM A582/A582M

**PTA Tube:**

Manufactured from Clear Butyrate. Tested in conformance with ASTM D542, ASTM D149, ASTM D696 and ASTM D257.

**Dimensions:**

Hot-Dip Galvanized: #3 (grade 60) rebar rod, 3/16" notched dovetail head.  
Stainless Steel: 3/8" Rod, 3/16" notched dovetail head.  
*Other diameters and gauges available, including heavy-duty styles for hurricane velocity wind loads.*

**Length:**

7 1/2" Rod/Rebar Standard       Custom \_\_\_\_\_

**Finishes:**

Hot-Dip Galvanized (#3, grade 60, rebar rod)  
 Stainless Steel Type 304 ( 3/8" rod)  
 Stainless Steel Type 316 ( 3/8" rod)

**Note: H&B recommends Stainless Steel for maximum protection against corrosion.**

**Note:** NS Neoprene sponge also available. Submittal sheet available for download from h-b.com or upon request.

**IMPORTANT:** Since each construction project is unique, the appropriate selection and use of any product contained herein must be determined by competent architects, engineers and other appropriate professionals who are familiar with the specific requirements of the project in question. This drawing and/or data sheet is the confidential and proprietary information of Hohmann & Barnard, Inc. and is not to be reproduced, copied or disclosed, in whole or in part, without the prior written consent of H&B.

**HOHMANN & BARNARD, Inc.**  
CORPORATE HEADQUARTERS  
30 Rasons Court | Hauppauge, NY 11788  
T: 800.645.0616 F: 631.234.0683  
[www.h-b.com](http://www.h-b.com)

**Branch/Subsidiary Locations:**  
ALABAMA - ARIZONA - ILLINOIS  
MARYLAND - NEW YORK  
PENNSYLVANIA - TEXAS - UTAH  
CANADA

© 2013-2017 MiTek®