

STAINLESS STEEL STONE ANCHORS #309 STONE ANCHOR

The appropriate selection and use of any product contained herein must be determined by competent architects, engineers and other professionals who are familiar with the specific requirements of the project.

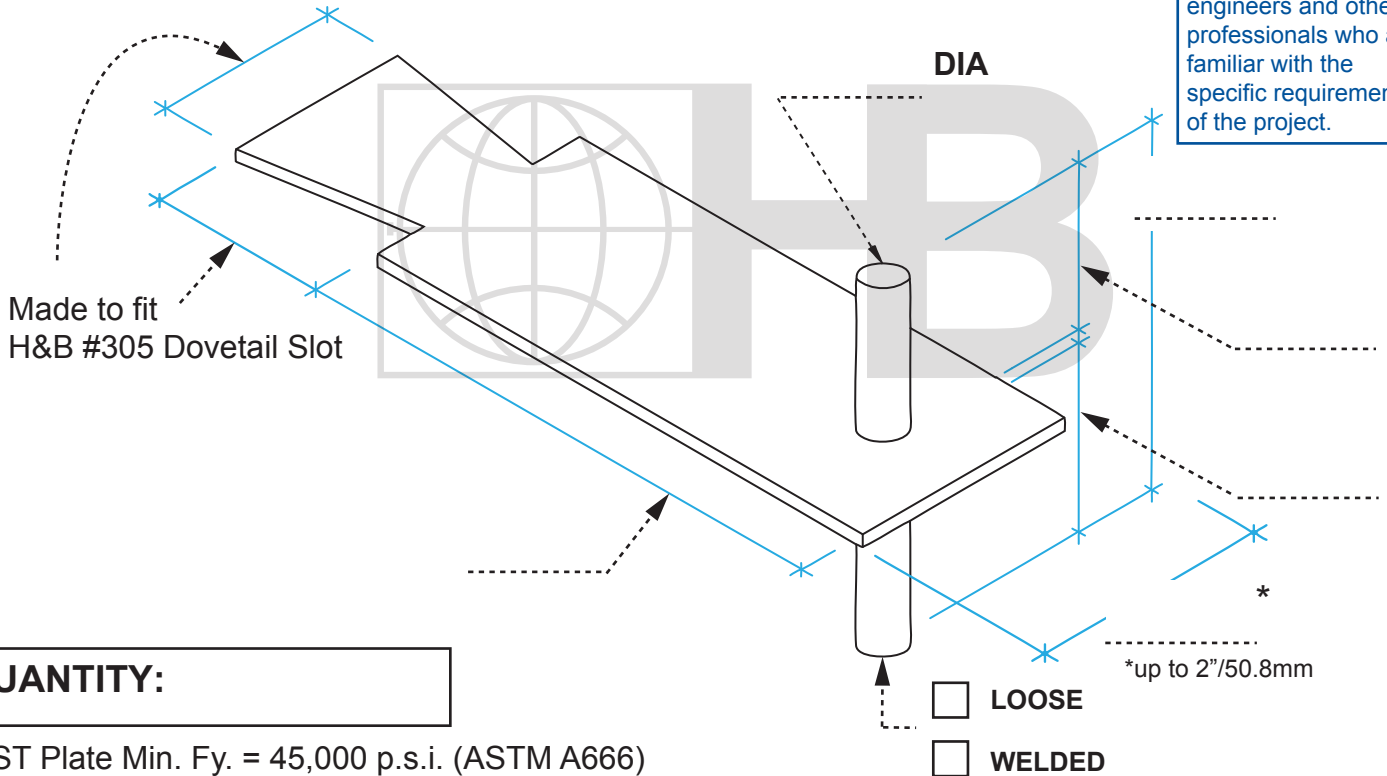

DRAWINGS FOR ILLUSTRATIVE PURPOSES ONLY

QUANTITY:

ST/ST Plate Min. Fy. = 45,000 p.s.i. (ASTM A666)
ST/ST Rounds Min. Fy. = 75,000 p.s.i. (ASTM A276/A276M)

FINISH:		THICKNESS:		
<input type="checkbox"/> TYPE 304 Stainless Steel	<input type="checkbox"/> TYPE 316 Stainless Steel	<input type="checkbox"/> 12 ga./2.78 mm	<input type="checkbox"/> 3/16"/4.7 mm	<input type="checkbox"/> OTHER _____
H&B recommends the exclusive use of 304 or 316 Stainless Steel for stone anchorage.		<input type="checkbox"/> 1/8"/3.2 mm	<input type="checkbox"/> 1/4"/6.3 mm	

PROJECT NAME:	CONTACT INFO
LOCATION:	Name :
NOTES:	Company:
	Phone: FAX:
	Email:
Due to fabrication requirements and lead times, once a custom anchor order has been scheduled it cannot be cancelled and will not be returnable. Verify all measurements before signing this form. Any changes after the initial order is placed will require a new signed form, and an additional charge. By signing this document, you agree to the terms stated above and accept full responsibility for the accuracy of measurements.	Orders without a signature will not be processed.
	ACCEPTED BY: _____
	DATE: _____