

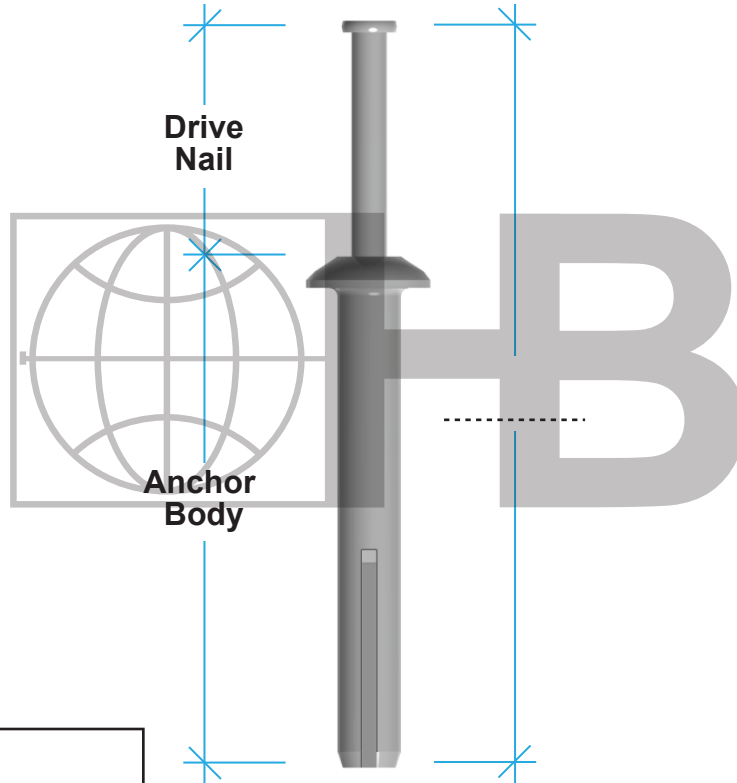

STAINLESS STEEL STONE ANCHORS NAIL-IN EXPANSION ANCHOR

The appropriate selection and use of any product contained herein must be determined by competent architects, engineers and other professionals who are familiar with the specific requirements of the project.



QUANTITY:

DRAWINGS FOR ILLUSTRATIVE PURPOSES ONLY

<p>FINISH (DRIVE NAIL):</p> <p><input type="checkbox"/> TYPE 304 Stainless Steel</p> <p><input type="checkbox"/> Carbon Steel</p>	<p>THICKNESS:</p> <p><input type="checkbox"/> 3/16"/4.7 mm</p> <p><input type="checkbox"/> 1/4"/6.3 mm</p>
--	---

Drive Nail furnished in Type 304 ST/ST, or Carbon Steel. Anchor Body is Zamac Alloy.

<p>PROJECT NAME:</p> <p>LOCATION:</p> <p>NOTES:</p>	<p>CONTACT INFO</p> <p>Name :</p> <p>Company:</p> <p>Phone: FAX:</p> <p>Email:</p> <hr/> <p>Due to fabrication requirements and lead times, once a custom anchor order has been scheduled it cannot be cancelled and will not be returnable. Verify all measurements before signing this form. Any changes after the initial order is placed will require a new signed form, and an additional charge. By signing this document, you agree to the terms stated above and accept full responsibility for the accuracy of measurements.</p> <p>Orders without a signature will not be processed.</p> <p>ACCEPTED BY: _____</p> <p>DATE: _____</p>
--	---

HOHMANN & BARNARD, Inc.
30 Rasons Court | Hauppauge, NY 11788
CORPORATE HEADQUARTERS
T: 800.645.0616 F: 631.234.0683
www.h-b.com

Branch/Subsidiary Locations:
ALABAMA - ARIZONA - ILLINOIS
MARYLAND - NEW YORK - PENNSYLVANIA
TEXAS - MARYLAND - UTAH - CANADA