

HOOVER TREATED WOOD PRODUCTS, INC.

TECHNICAL NOTE

FOR ADDITIONAL INFORMATION: 1-800-TEC-WOOD (832-9663)

Fire-Retardant-Treated Wood Framed Wall Assemblies

GENERAL INFORMATION

Fire-resistant construction assemblies (walls, floors, roofs) and elements (beams, columns), that perform satisfactorily in standard fire resistance tests, are documented in building codes, standards, test reports and directories of testing laboratories. Over the years, a considerable amount of accumulated test data allowed the standardization of many fire-resistant designs involving generic (non-proprietary) materials, such as wood, steel, concrete, masonry, clay tile, "Type X" gypsum wallboard, and various plasters. These generalized designs and methods are documented in the *International Building Code*, (IBC)¹ sections 720 and 721 with detailed explanatory figures, tables, formulas, and charts. Fire resistant designs that incorporate proprietary materials pertaining to specific manufacturers and/or patented are documented by test laboratories in test reports and directories of test laboratories and trade associations. The major sources of documented construction designs rated for fire resistance are described below.

UL DIRECTORY

Underwriters Laboratories Inc. (UL) conducts tests of various building components and fire protection materials. The assemblies are tested under recognized testing procedures, including ASTM E119² and ANSI/UL 263³, which are essentially the same. When the assembly complies with the acceptance criteria of the fire test standard, a detailed report is provided including its description and performance in the test, pertinent details, and specifications of materials used. A summary of the important features is produced and given a UL designation. The assembly details are shown in the UL Fire Resistance Directory, Volume 1 and their Online Certifications.

Volume 1⁴ of the UL directory contains hourly fire resistance ratings for beams, floors, roofs, columns, walls and partitions. Assemblies designated with a U3XX are wood framed wall assemblies. These assemblies list untreated wood. However, UL makes the statement in their "General Information for Fire Resistance Ratings" that, "***Wood stud walls may contain fire-retardant-treated studs as well as untreated wood studs. The use of fire-retardant-treated plywood (wood structural panels) may be used in Designs that contain use of untreated plywood when all other specified attributes are equivalent to the wood structural panel used in the Design.***" Using fire-retardant-treated wood in these assemblies allows wood-framed wall systems where noncombustible materials are typically required in Type I, II, III, and IV Construction.

TRADE ASSOCIATIONS

To facilitate the design process, numerous associations publish wall design configurations meeting various fire criteria. Examples of these publications are Fire Rated Wood Floor and Wall Assemblies (DCA-3)⁵ published by the American Wood Council, Fire Rated Systems Design/Construction Guide (W305)⁶ published by APA-The Engineered Wood Association, and Fire Resistance Design Manual (GA-600)⁷ published by the Gypsum Association (see Appendix).

BUILDING CODE

The International Building Code (IBC)¹ requires that exterior walls conform to the required fire-resistance ratings of Tables 601 and 602. Exterior bearing walls must comply with the more restrictive requirements of both tables, whereas nonbearing exterior walls need only comply with Table 602.

The following are the code sections in the International Building Code for Fire-Retardant-Treated Wood (FRTW) exterior walls.

EXTERIOR WALL USES FOR FRTW	IBC 2006
Type I and II Exterior nonbearing walls with 0 fire resistance or NC materials required	603.1 #1.2
Exterior bearing and nonbearing walls in joisted masonry (Type III) construction.	602.3
Exterior bearing and nonbearing walls in heavy timber (Type IV) construction.	602.4

Fire-rated assemblies are required for the exterior bearing walls in Type III and Type IV construction. The fire-resistance rating for bearing walls in Type III is two hours. For nonbearing walls with less than 30 feet fire separation distance the requirement is one hour; over 30 feet, no fire rating is required. When the fire separation distance is greater than five feet the rating is from the interior side only (Section 704.5); when 5 feet or closer, the rating must be from both the interior and exterior side.

To qualify under ASTM E119 an assembly must maintain structural stability, limit transmission of heat, and limit transmission of hot gases. Failure to do any one of the three will result in the assembly not passing the test. All three are important for interior fire rated assemblies. For exterior walls the building code recognizes the distance between walls can influence how a fire can spread from building to building and has modified the acceptance criteria. The exception in Section 703.2 states, in part:

“...compliance with the ASTM E 119 criteria for unexposed surface temperature rise and ignition of cotton waste due to passage of flame or gases is required only for a period of time corresponding to the required fire-resistance rating of an exterior nonbearing wall with the same fire separation distance...”

For a bearing wall in Type III construction with a fire separation distance of more than 30 feet the code is concerned with only structural stability; the limit on transmission of heat and hot gases is not considered. This provides a designer with much latitude in materials for use on exterior side of the wall. In Type III construction wood used in the exterior wall must be fire-retardant treated.

EXAMPLES OF TWO HOUR FIRE RATED BEARING WALL ASSEMBLIES WITH FIRE SEPARATION DISTANCE GREATER THAT 5 FEET

The modified assemblies shown in this section are based on UL 301 and UL 371. The original assemblies, as tested, have fire protection from both sides. As permitted by the code, the modified assemblies have the fire protection from the inside only.

U301 non-fire side modified

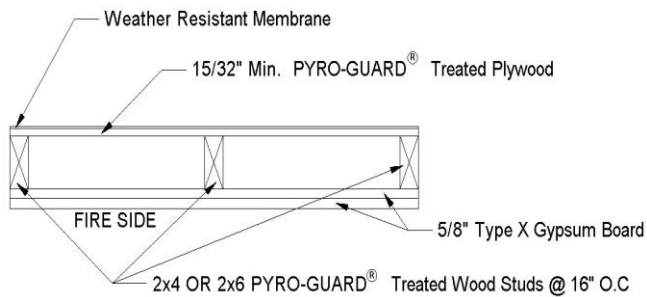

Note: See GA File No. WP 8416 for construction details for fire side.
Follow manufacturer's recommendations for exterior membranes

U371 non-fire side modified

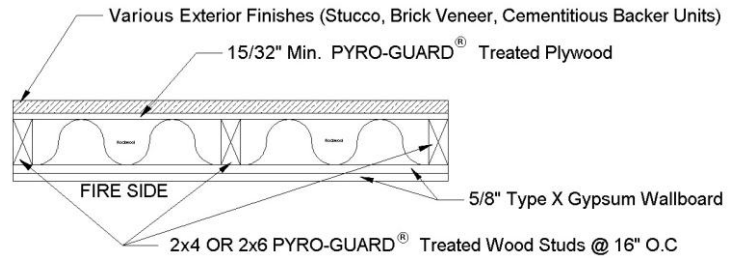

Note: See GA File No. WP 8417 for construction details for fire side
Follow manufacturer's recommendations for exterior membranes

EXAMPLES OF TWO HOUR FIRE RATED BEARING WALL ASSEMBLIES WITH LESS THAN 5 FEET FIRE SEPARATION DISTANCE

For illustration purposes, three UL assemblies are shown: U301, U302, and U371. An additional assembly (15-1.6) which can be found in IBC Table 720.1(2) is also shown. Ratings for these two-hour assemblies are from both sides. Figure 1 is a modified version of UL Design U301. This assembly has been modified by adding Pyro-Guard[®] plywood to the exterior side of the wall. Section 703.3 of the IBC allows modification of an assembly when the modification does not adversely affect the rating. The modification is in accordance with the ten rules for fire endurance developed by T.Z. Harmathy. The ten rules establish the impact of modifying an assembly and Rule #2 applies in this case, "The fire endurance of a construction does not decrease with the addition of further layers." According to Rule #2, Pyro-Guard[®] plywood can be added to any assembly to provide additional lateral load resistance to the assembly. By adding a weather resistant membrane to UL U301, the gypsum board can also be protected from exterior exposure and again Rule #2 applies.

Figure 1 - UL Design U301, Modified

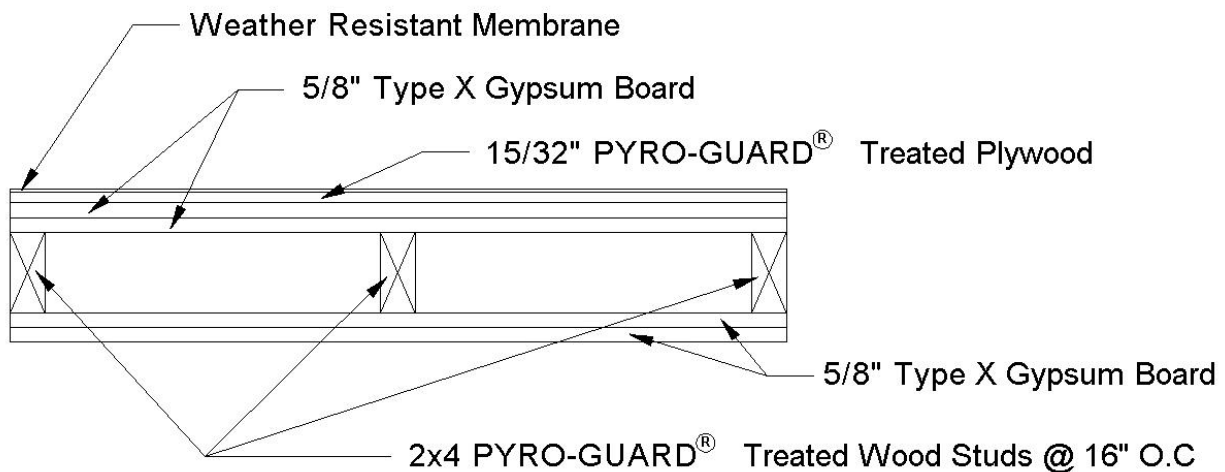

Note: See GA File No. WP 8416 for construction details.
The Pyro-Guard[®] plywood can be placed against the studs or on the outside of the gypsum wallboard

Figure 2 is UL Design U302 which utilizes brick veneer for the exterior finish and provides the required fire resistance to both sides of the wall. When resistance to lateral loads is required, Pyro-Guard[®] treated plywood can be added to the exterior side without adversely affecting the fire resistance of the assembly.

Figure 2 - UL Design U302

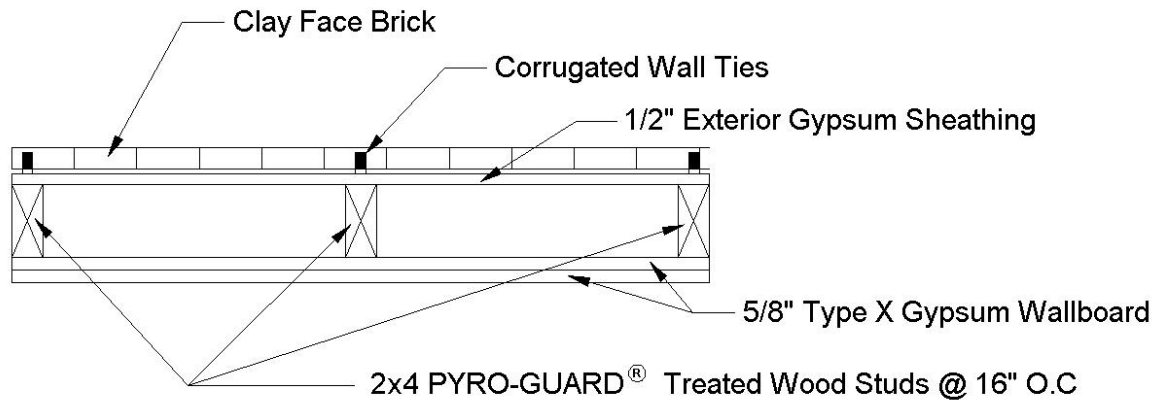

Note: See GA File No. WP 8410 for construction details.
Local authority may permit substitution of the Pyro-Guard® treated plywood for the gypsum sheathing when fire resistance is needed only from the interior.

Figure 3 demonstrates UL Design U371 which is similar to UL Design U302 in that it allows brick veneer or stucco as the exterior membrane. This assembly shows the use of a wood sheathing material for resisting lateral loads and unlike U302, which requires two layers, because the exterior membranes are limited, this assembly requires only one layer of gypsum sheathing.

Figure 3 - UL Design U371

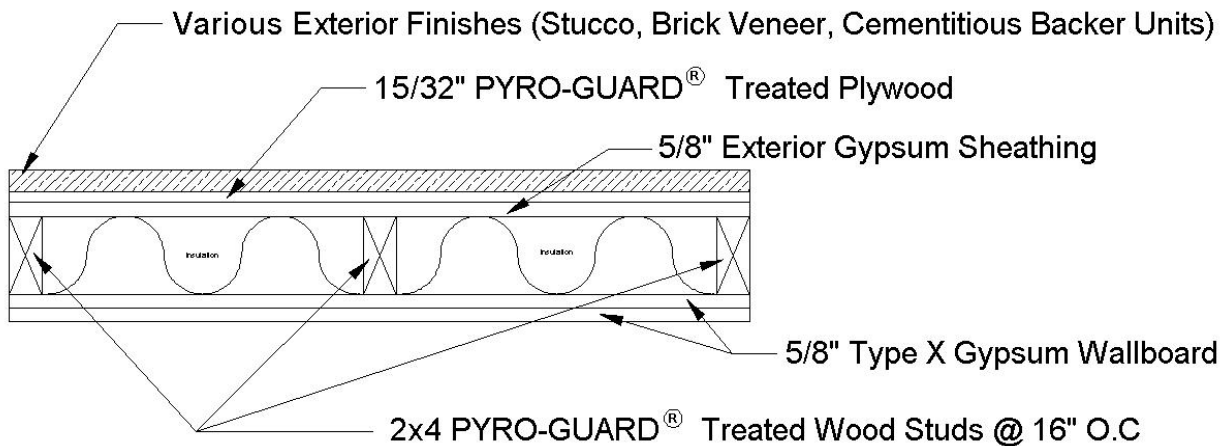

Note: See GA File No. WP 8417 for construction details.
Pyro-Guard® treated plywood maybe installed over or under the gypsum sheathing.

Figure 4 illustrates a design from Table 720.1(2) of the IBC.

Figure 4 - IBC Design 720.1(2) 15-1.6

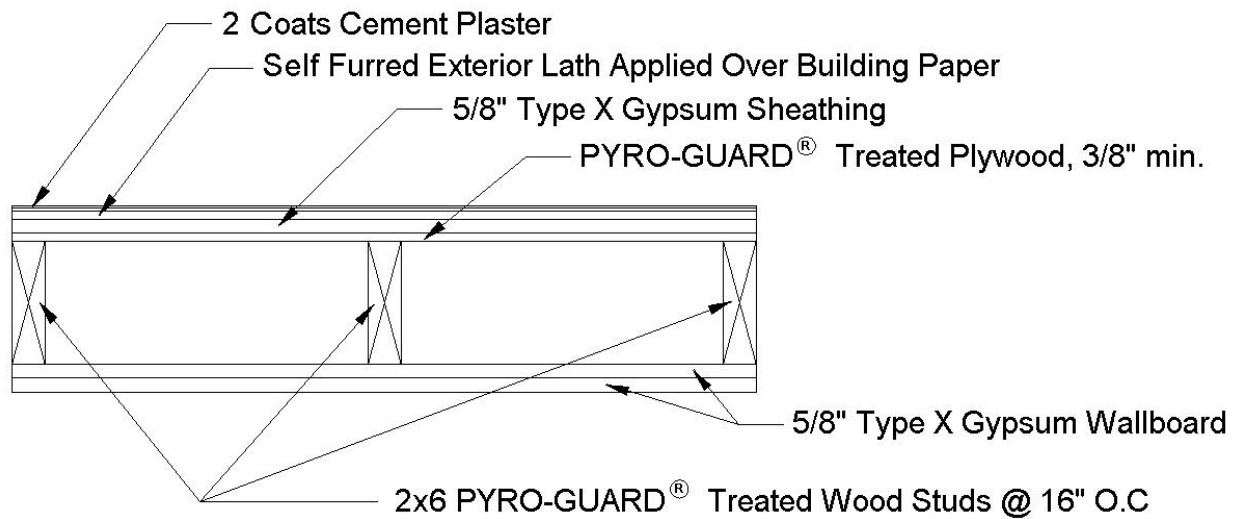

Note: See GA File No. WP 8420 for construction details.
 Pyro-Guard® treated plywood maybe installed over or under the gypsum sheathing

EXAMPLES OF ONE-HOUR FIRE RATED ASSEMBLIES

Depending on the fire separation distance the fire-resistance rating for the nonbearing walls can be either one hour or none. There are many assemblies available in several documents. The Component Added Method (CAM) in Section 721.6 of the IBC also provides a useful method to calculate the fire resistance of wood framed assemblies. Two assemblies are provided. Figure 5 is for a wall with fire resistance on both sides and Figure 6 is for fire resistance from the interior only. The code requires the wall to be rated from both sides when the fire separation distance is five feet or less. The two assemblies shown in the following section can be either bearing or nonbearing.

Figure 5 - Fire Separation Distance 5'-0" or less

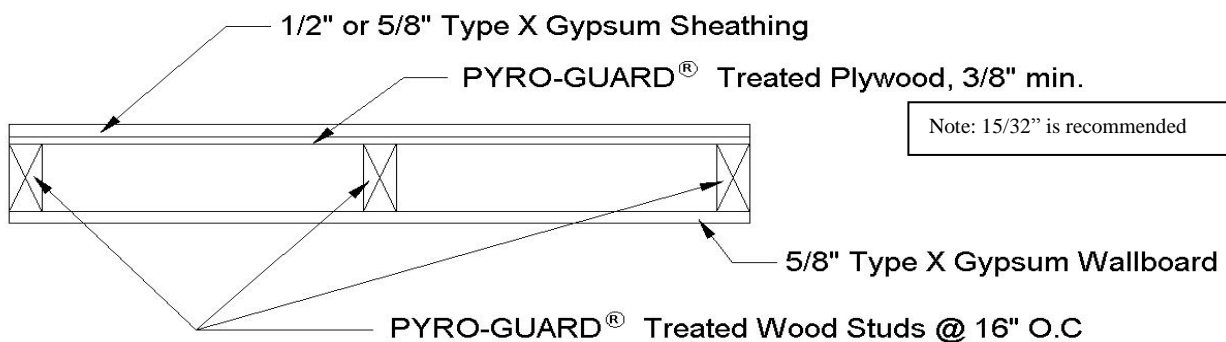

Note: 15/32" is recommended

Note: Insulation is optional
 Additional membranes may be installed over the Pyro-Guard® treated plywood; e.g., wood or other material siding, brick, stucco, plaster.

Figure 6 - Fire Separation Distance > 5'-0"

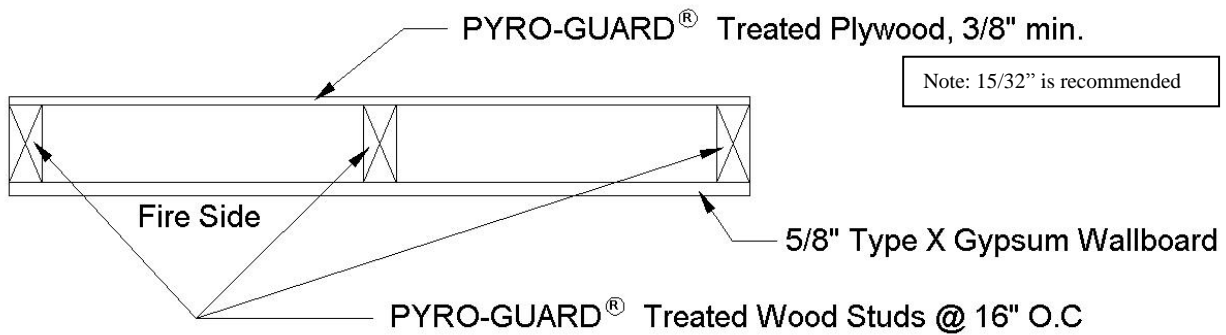

Note: Insulation is optional
Additional membranes may be installed over the Pyro-Guard® treated plywood; e.g., wood or other material siding, brick, stucco, plaster.
Gypsum sheathing may be installed over or under the Pyro-Guard® treated plywood.

REFERENCES

- [1] International Code Council, Inc. (ICC) (2006), *International Building Code, 2006*, Falls Church, VA.
- [2] American Society for Testing and Materials (ASTM) (2007), *Standard Test Methods for Fire Tests of Building Construction and Materials*, Specification No. E119-07, West Conshohocken, PA.
- [3] Underwriters Laboratories Inc. (UL) (2003), *Fire Tests of Building Construction and Materials*, Thirteenth Edition, Standard No. UL 263, Northbrook, IL.
- [4] Underwriters Laboratories Inc. (UL) (2003), *Fire Resistance Directory, 2003*, Vol. 1, Northbrook, IL.
- [5] American Wood Council (AWC) (2002), *Fire Rated Wood Floor and Wall Assemblies (DCA-3)*, Washington, DC.
- [6] APA-The Engineered Wood Association (APA) (2005), *Fire Rated Systems Design/Construction Guide (W305)*, Tacoma, WA.
- [7] Gypsum Association (GA) (2009), *Fire Resistance Design Manual (GA-600-2009)*, Hyattsville, MD.

By Joe Holland and Dave Bueche, 08-08-11

Appendix A – Extracts from GA-600-2009 Fire Resistance Design Manual

EXTERIOR WALLS																								
GA FILE NO. WP 8410	GENERIC	2 HOUR FIRE																						
<p style="text-align: center;">GYPSUM WALLBOARD, WOOD STUDS, GYPSUM SHEATHING, CLAY BRICK</p> <p>EXTERIOR SIDE: Base layer 1/2" gypsum sheathing applied parallel or at right angles to 2 x 4 wood studs 16" o.c. with 1 3/4" galvanized roofing nails, 0.125" shank, 7/16" heads, 6" o.c. Face layer 2" x 4" x 8" clay brick with 1" air space between brick and exterior sheathing. No. 20 gage galvanized wire ties attached to each stud with 8d coated nails, 2 3/8" long, 0.113" shank, 9/32" head, at every 6th course of bricks.</p> <p>INTERIOR SIDE: Base layer 5/8" type X gypsum wallboard or gypsum veneer base applied parallel or at right angles to studs with 6d coated nails, 1 7/8" long, 0.0915" shank, 1/4" heads, 8" o.c. Face layer 5/8" type X gypsum wallboard or gypsum veneer base applied parallel to or at right angles to studs with 8d coated nails, 2 3/8" long, 0.113" shank, 9/32" heads, 8" o.c. (LOAD-BEARING)</p>			<p>Thickness: 10 1/8" Fire Test: UL R1505-1, 2, 4-22-65, UL Design U302; ULC Design U302</p>																					
GA FILE NO. WP 8415	GENERIC	2 HOUR FIRE																						
<p style="text-align: center;">GYPSUM SHEATHING, GYPSUM WALLBOARD, WOOD STUDS</p> <p>EXTERIOR SIDE: Base layer 5/8" type X gypsum sheathing applied parallel or at right angles to 2 x 4 wood studs 24" o.c. with 6d coated nails, 1 7/8" long, 0.085" shank, 1/4" heads, 24" o.c. Face layer 5/8" type X gypsum sheathing applied parallel or at right angles to studs with 8d coated nails, 2 3/8" long, 0.100" shank, 1/4" heads, 8" o.c. Exterior cladding attached through sheathing to studs.</p> <p>INTERIOR SIDE: Base layer 5/8" type X gypsum wallboard or gypsum veneer base applied parallel or at right angles to studs with 6d coated nails, 1 7/8" long, 0.085" shank, 1/4" heads, 24" o.c. Face layer 5/8" type X gypsum wallboard or gypsum veneer base applied parallel or at right angles to studs with 8d coated nails, 2 3/8" long, 0.100" shank, 1/4" heads, 8" o.c.</p> <p>Joists staggered 24" each layer and side. (LOAD-BEARING)</p>			<p>Thickness: 6 1/8" without exterior cladding Fire Test: See WP 4135 (FM WP 360, 9-27-74)</p>																					
GA FILE NO. WP 8416	PROPRIETARY*	2 HOUR FIRE																						
<p style="text-align: center;">GYPSUM WALLBOARD, GLASS MAT GYPSUM SUBSTRATE, WOOD STUDS</p> <p>EXTERIOR SIDE: Base layer 5/8" proprietary type X glass mat gypsum substrate (sheathing) applied parallel or at right angles to 2 x 4 wood studs 16" o.c. with 1 7/8", 0.0915" shank, 1/4" head, galvanized roofing nails 6" o.c. Face layer 5/8" proprietary type X glass mat gypsum substrate (sheathing) applied parallel or at right angles to studs to studs with 2 3/8", 0.113" shank, 9/32" head, galvanized roofing nails 8" o.c. Exterior cladding to be attached through glass mat gypsum panel to studs.</p> <p>INTERIOR SIDE: Base layer 5/8" proprietary type X gypsum board applied parallel or at right angles to studs with 1 7/8", 0.0915" shank, 1/4" head nails 6" o.c. Face layer 5/8" proprietary type X gypsum board applied parallel or at right angles to studs with 2 3/8", 0.113" shank, 9/32" head nails 8" o.c.</p> <p>Joists staggered 16" each layer and side. (LOAD-BEARING)</p> <p style="text-align: center;">PROPRIETARY GYPSUM PANEL PRODUCTS</p> <table border="0"> <tr> <td>CertainTeed Gypsum Inc.</td> <td>-</td> <td>5/8" ProRoc® Type X Gypsum Panels</td> </tr> <tr> <td></td> <td>-</td> <td>5/8" GlasRoc® Sheathing Type X Gypsum Panels</td> </tr> <tr> <td>CertainTeed Gypsum Canada Inc.</td> <td>-</td> <td>5/8" ProRoc® Type X Gypsum Panels</td> </tr> <tr> <td>National Gypsum Company</td> <td>-</td> <td>5/8" e2XP® FIRE-SHIELD® Gypsum Sheathing</td> </tr> <tr> <td></td> <td>-</td> <td>5/8" Gold Bond® Brand FIRE-SHIELD® Gypsum Board</td> </tr> <tr> <td>Temple-Inland</td> <td>-</td> <td>5/8" GreenGlass Type X</td> </tr> <tr> <td></td> <td>-</td> <td>5/8" Type X</td> </tr> </table>		CertainTeed Gypsum Inc.	-	5/8" ProRoc® Type X Gypsum Panels		-	5/8" GlasRoc® Sheathing Type X Gypsum Panels	CertainTeed Gypsum Canada Inc.	-	5/8" ProRoc® Type X Gypsum Panels	National Gypsum Company	-	5/8" e2XP® FIRE-SHIELD® Gypsum Sheathing		-	5/8" Gold Bond® Brand FIRE-SHIELD® Gypsum Board	Temple-Inland	-	5/8" GreenGlass Type X		-	5/8" Type X		<p>Thickness: 6 1/8" Approx. Weight: 12 psf Fire Test: Based on UL R3660/R15187, 2-4-02; UL R6937, 08NK02787, 9-19-08; UL Design U301</p>
CertainTeed Gypsum Inc.	-	5/8" ProRoc® Type X Gypsum Panels																						
	-	5/8" GlasRoc® Sheathing Type X Gypsum Panels																						
CertainTeed Gypsum Canada Inc.	-	5/8" ProRoc® Type X Gypsum Panels																						
National Gypsum Company	-	5/8" e2XP® FIRE-SHIELD® Gypsum Sheathing																						
	-	5/8" Gold Bond® Brand FIRE-SHIELD® Gypsum Board																						
Temple-Inland	-	5/8" GreenGlass Type X																						
	-	5/8" Type X																						

Appendix A – Extracts from GA-600-2009 Fire Resistance Design Manual (continued)

EXTERIOR WALLS

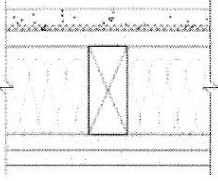
GA FILE NO. WP 8417	PROPRIETARY*	2 HOUR FIRE	
GYPHUM WALLBOARD, WOOD STUDS, GYPHUM SHEATHING, STUCCO NETTING, CEMENT STUCCO			Thickness: 6 1/4" Approx. Weight: 17 psf Fire Test: UL R3501, 03NK2475, 5-21-03, UL Design U371
<p>EXTERIOR SIDE: Base layer 5/8" proprietary type X gypsum sheathing applied parallel or at right angles to 2 x 4 wood studs 16" o.c. with 1 3/4", 0.125" shank, 7/16" head galvanized roofing nails 8" o.c. or 2" Type S drywall screws 8" o.c. Pre-furred wire stucco netting applied over gypsum sheathing with 1 1/4" x 1" steel staples 7" o.c. Portland cement stucco, 3/4", applied over stucco netting.</p> <p>INTERIOR SIDE: Base layer 5/8" proprietary type X gypsum wallboard or gypsum veneer base applied parallel or at right angles to studs with 1 1/4" Type S drywall screws 12" o.c. Face layer 5/8" proprietary type X gypsum wallboard or gypsum veneer base applied parallel or at right angles to studs with 2" Type S drywall screws 12" o.c.</p> <p>Joints staggered 16" each layer and side. (LOAD-BEARING)</p> <p style="text-align: center;">PROPRIETARY GYPHUM BOARD</p> <p>National Gypsum Company - 5/8" Gold Bond® Brand FIRE-SHIELD® Gypsum Board</p> <p style="padding-left: 150px;">- 5/8" Gold Bond® Brand FIRE-SHIELD® Gypsum Sheathing</p>			

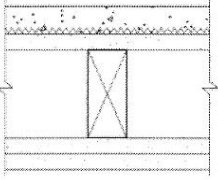
GA FILE NO. WP 8420	GENERIC	2 HOUR FIRE	
WOOD STUDS, CEMENT STUCCO, WIRE MESH, GYPHUM WALLBOARD			Thickness: 8 5/8" Fire Test: UC, 12-21-67
<p>EXTERIOR SIDE: Base layer 5/8" type X gypsum sheathing applied parallel to 2 x 6 fire retardant treated wood studs 16" o.c. with 6d coated nails, 1 7/8" long, 0.0915" shank, 1/4" heads, 12" o.c. and covered with a single layer fire resistant protective weather retarder paper stapled along each edge at 16" o.c. Galvanized self-furring wire mesh applied over sheathing with 8d galvanized roofing nails, 2 3/8" long, 0.113" shank, 9/32" heads, 6" o.c. Cement-stucco applied over wire mesh in two 1/2" thick coats with bonding agent applied between coats.</p> <p>INTERIOR SIDE: Base layer 5/8" type X gypsum wallboard or gypsum veneer base applied parallel to studs with 6d coated nails, 1 7/8" long, 0.0915" shank, 1/4" heads, 12" o.c. Face layer 5/8" type X gypsum wallboard or gypsum veneer base applied at right angles to studs with 8d coated nails, 2 3/8" long, 0.113" shank, 9/32" heads, 8" o.c. at edges and 12" o.c. at intermediate studs. (LOAD-BEARING)</p>			

This Space Left Blank

Appendix B – Harmathy's 10 Rules of Fire Endurance

Rule 1. *The "thermal" fire endurance of a construction consisting of a number of parallel layers is greater than the sum of the "thermal" fire endurance characteristics of the individual layers when exposed separately to fire.*

Rule 2. *The fire endurance of a construction does not decrease with the addition of further layers.*

Rule 3. *The fire endurance of constructions containing continuous air gaps or cavities is greater than the fire endurance of similar constructions of the same weight, but containing no air gaps or cavities.*

Rule 4. *The farther an air gap or cavity is located from the exposed surface, the more beneficial its effect on the fire endurance.*

Rule 5. *The fire endurance of an assembly cannot be increased by increasing the thickness of completely enclosed air layer.*

Rule 6. *Layers of materials of low thermal conductivity are better utilized on the side of the construction on which fire is more likely to happen.*

Rule 7. *The fire endurance of asymmetrical constructions depends on the direction of heat flow.*

Rule 8. *The presence of moisture, if it does not result in explosive spalling, increases the fire endurance.*

Rule 9. *Load-supporting elements, such as beams, girders and joists, yield higher fire endurance when subject to fire endurance tests as parts of floor, roof or ceiling assemblies than they would when tested separately.*

Rule 10. *The load-supporting elements (beams, girders, joists, etc.) of a floor, roof or ceiling assembly can be replaced by such other load-supporting elements which, when tested separately, yielded fire endurance not less than that of the assembly.*